

Instruction Manual

for the

SSQ-2F Controller Board

v3.22

For Rife Plasma Tube Systems

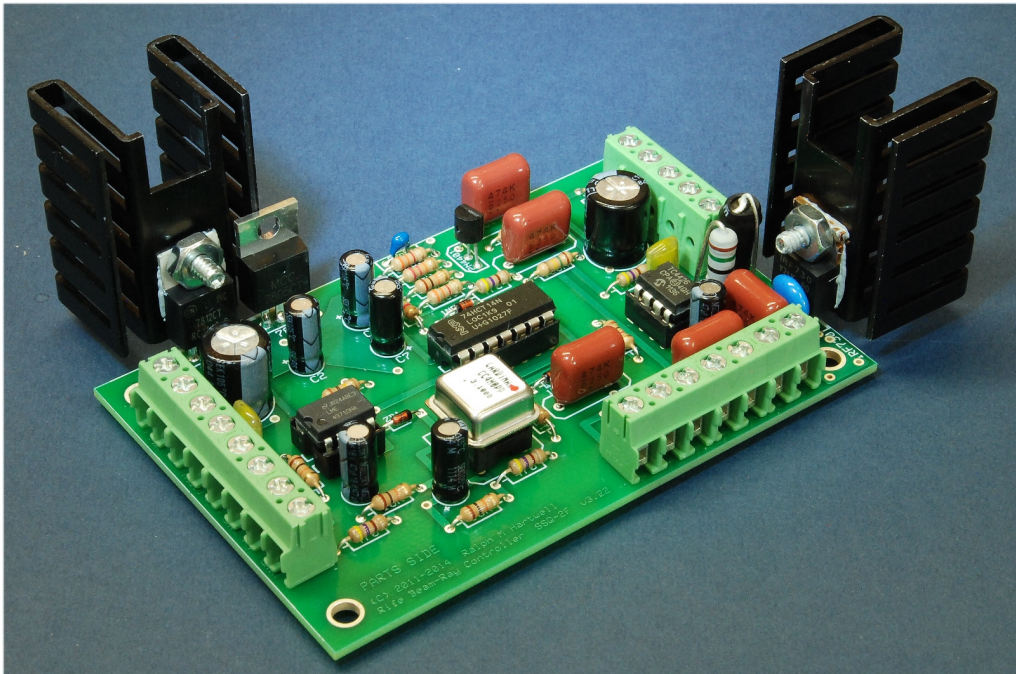

Manual v1.02

© 2014 by Ralph Hartwell
Spectrotek Services
All rights reserved

*** LEGAL AND MEDICAL DISCLAIMER ***

Spectrotek Services and Ralph M. Hartwell ARE NOT RESPONSIBLE for any damage or injuries of any sort or form that may be sustained by any person or persons, any animal, or to any equipment or any other thing or things while anyone is using, modifying, testing, or experimenting with the SSQ-2F in any manner whatsoever. This device has not been inspected or approved by any governmental or medical agency or inspection service. No medical claims are made for, nor implied by, the sale or use of this device. Using the SSQ-2F is done solely at your own risk.

You are advised to always consult with your physician or other health care professional at any time should you have or think you might have a health problem of some sort. Please check with your physician or other health care professional before starting any diet, exercise, taking OTC medications or supplements and especially before taking any prescribed medication. Never stop taking any prescribed medications without first consulting your physician.

Index and Table of Contents

Legal and Medical Disclaimer	2
About the SSQ-2F v3.22	7
About the Original SSQ-2F	7
Interconnection Block Diagrams	10
Connections	11
Mounting the SSQ-2F v3.22	15
Plan Layout of RF Shield	19
RF Shielding to Prevent Interference to Other Devices	20
Heat Sink – Voltage Regulator	21
Heat Sink and Cooling the IRF730 RF Output Amplifier	21
Removing and Replacing the Heat Sink of the IRF730	22
Metering the Square Wave Duty Cycle	23
General Operation of the SSQ-2F v3.22	24
Power Supply	24
Audio Input Signal	25
Modes of Operation	25
Operation with Square Wave Audio Signals	26
Driving an External Solid State RF Amplifier	27
Setting the RF Drive Level for an External RF Amplifier	28
Turn On Caution for External RF Amplifiers	28
Driving an External Vacuum Tube RF Amplifier	29
Connecting the SSQ-2F to a Vacuum Tube Amplifier	30

RF Coupling Systems	31
Commercial Antenna Tuners	31
3.1 MHz Link Coupler System	32
Tuning the System to Resonance	32
Tuning Waveforms	33
Driving a Contact System with the SSQ-2F	34
Specifications	38
Warranty Information	40
Contact Us	40
Schematic Diagram	41
Waveforms	42-47

List of Figures

Figure 1, Page 10 – Block diagram of a typical Rife plasma system using the SSQ-2F v3.22.

Figure 2, Page 10 – Block diagram of a typical Rife contact system using the SSQ-2F v3.22.

Figure 3, Page 11 – SSQ-2F v3.22 connector identification.

Figure 4, Page 16 – SSQ-2F with RF shield installed.

Figure 5, Page 17 – SSQ-2F with RF shield installed.

Figure 6, Page 18 – SSQ-2F with RF shield installed.

Figure 7, Page 19 – Plan layout of the RF shield for the SSQ-2F v3.22.

Figure 8, Page 25 – Operating modes of the SSQ-2F v3.22.

Figure 9, Page 27 – RF driver capacitor installed on SSQ-2F

Figure 10, Page 28 – RF power output with RF driver capacitor installed

Figure 11, Page 29 – RF power output for high power use

Figure 12, Page 33 – Tuning waveforms

Figure 13, Page 35 – Contact Device Adapter Schematic

Figure 14, Page 36 – RF volts output for use as a contact device driver

Figure 15, Page 41 – Schematic diagram of the SSQ-2F v3.22.

Figure 16, Page 42 – Waveform of the 6 KHz audio signal at TP1.

Figure 17, Page 42 – Waveform of the 6 KHz 50% duty cycle square wave at TP2 in X1 Mode.

Figure 18, Page 43 – Waveform of the 12 KHz 50% duty cycle square wave at TP2 in X2 Mode.

Figure 19, Page 43 – Waveform of the 3.1 MHz carrier wave drive signal at U3, pins 5 & 7.

Figure 20, Page 44 – Waveform of the modulated RF carrier and audio modulation signal in X1 Mode.

Figure 21, Page 44 – Waveform of the modulated RF carrier and audio modulation signal in X2 Mode.

Figure 22, Page 45 – Waveform of the high power modulated RF carrier and audio modulation signal in X1 Mode.

Figure 23, Page 46 – Waveform of the high power modulated RF carrier modulated by 210 KHz audio signal.

Figure 24, Page 47 – Waveform of individual RF cycles of the 3.1 MHz carrier output at high power.

About the SSQ-2F v3.22

The SSQ-2F v3.22 is an updated and improved version of the SSQ-2F v1.41, 3.10 and the v3.21. Because of its special functions and abilities, it is important to read and understand the contents of this operations manual to prevent damage to the unit. The SSQ-2F v3.22 is a component of either a plasma tube or a contact system. It is designed to be incorporated into such systems by the experimenter. It is not a stand-alone device. Some fabrication and system integration will be required to obtain the best performance of your SSQ-2F v3.22.

About the Original SSQ-2F v1.41

The basic SSQ-2F v1.41 3.1 MHz Rife Controller Board is a compact unit which is designed to generate a low-level, square wave modulated RF carrier wave suitable for use in various types of Rife instruments. In particular, it has been designed to implement the 3.1 or 3.3 MHz Rife Sweep protocol as outlined in the document posted at:

http://rifevideos.com/dr_rife_and_philip_hoylands_3.3mhz_sweep.html

This sweep protocol calls for the use of a 3.1 or 3.3 MHz carrier that is 100% modulated by a square wave that slowly sweeps between 500 and 25,000 Hz. Specific “spot” frequencies may also be used.

The SSQ-2F v1.41 is able to operate over the RF carrier range of 0.5 to 15.0 MHz simply by replacing the plug-in oscillator module with one of the correct frequency. Because of the requirements of the RF amplifier in the V3.nn units, the operating RF carrier range of these units is restricted to the range of 2.6 to 3.8 MHz.

Why is the SSQ-2F needed?

Most common computer sound cards are unable to reproduce sharp-edged square waves above a few hundred Hz, or even sine wave audio signals above 22,000 Hz, thus making computer sound cards virtually unusable when square wave modulated Rife systems are used.

Because most people will use computer sound cards to generate the required audio frequencies, all references to computer sound cards in this document also refer to audio waveforms that are recorded on MP3 players, CD, or DVD players and the like. It should be noted that MP3 players and CD and DVD players also suffer from the same inability to properly handle square waves.

The inability to generate sharp-edged square waves is a serious problem. In order to generate the higher frequency harmonic energy required for a Rife system to work properly, the leading and trailing edges of the square wave must be “sharp,” that is, it must have a very fast rise and fall time.

What does the SSQ-2F do?

To solve this problem, the SSQ-2F has been designed to accept sine wave audio frequencies within the frequency range that the computer sound card can generate. The SSQ-2F then doubles

those frequencies and converts them to clean square waves before modulating the 3.1 MHz carrier wave.

By doubling the input frequency, modulation frequencies of up to 44,000 Hz may be obtained using a standard computer sound card as the signal source. This allows the 3.1 MHz carrier to be modulated across the entire 500 to 25,000 Hz frequency range required for the 3.1 MHz Rife sweep. Because of the frequency doubling action of the SSQ-2F, the computer sound card need only generate sine wave signals within the frequency range of 250 to 12,500 Hz, which is within the range of any computer sound card.

What types of audio signals does the SSQ-2F accept?

The SSQ-2F will accept sine, triangle, or square wave signals as an input and convert them to square waves before using them to modulate the 3.1 MHz or 3.3 MHz RF carrier wave.

What range of frequencies does the SSQ-2F accept?

Although the SSQ-2F will accept modulation signals within the frequency range of 4 to 600,000 Hz, the controller has been designed for optimum operation within the frequency range of 40 to 60,000 Hz, thus making it practical to use computer sound cards, MP3 players, as well as CD and DVD players to generate the audio modulation signal. Of course, a standard frequency or function generator may be used as an audio signal source for the SSQ-2F.

What are the differences between the various versions of the SSQ-2F?

The SSQ-2F v1.41 was designed to provide a +5 volt or a +12 volt square wave output. This signal can be used to drive an external RF amplifier or it may be used as a low voltage contact device driver.

The SSQ-2F v3.22 differs from the SSQ-2F v3.10 in that the v3.22 has provision for a digital duty cycle meter, type M1-D. The cooling fan for the PA1 amplifier (if used) may be connected to the meter power connection on the v3.22 board so no separate power supply is required for the PA1 cooling fan. In addition, the audio gain circuit of the v3.22 has been changed to allow a wider range of audio input signal levels to be used.

The SSQ-2F v3.10 and the SSQ-2F v3.22 both contain a medium power RF amplifier built into the board itself. This allows the SSQ-2F to produce enough RF power to drive a medium sized Rife plasma tube without the need for an external RF power amplifier. Two power supplies are required for the SSQ-2F, one for the logic circuits, and one for the RF amplifier. Depending on the RF output power level required, it is sometimes possible to use just one power supply.

Alternatively, the SSQ-2F can be supplied with a factory installed modification for use as a low power RF drive source so that the operator may employ a higher powered, solid state, external RF amplifier, such as a KL-300 or a KL-500. The operator may easily remove this modification in the field, should this be desired. **This modification is NOT needed when the PA1 amplifier is used.**

I am uncomfortable soldering wires to circuit boards. What do I do?

All connections to the SSQ-2F are made using screw terminals, so no soldering is required.

How can I power the SSQ-2F?

The SSQ-2F may be powered from an power supply built from a number of laptop computer power adapters or any other suitable power supply..

Is the SSQ-2F v3.22 a complete Rife system?

The short answer is no.

The SSQ-2F v3.22 is designed to produce a correctly modulated RF signal for a Rife plasma system. It contains an on-board RF power amplifier that will produce up to 100 watts peak power output. This power level is suitable for driving a moderate sized Rife plasma tube. In order to drive a plasma tube, the output from the SSQ-2F must be coupled to the plasma tube through some form of matching system.

The SSQ-2F is also suitable for driving a high power RF amplifier, such as a KL-300 or a KL-500 amplifier. When used for this purpose, the SSQ-2F v3.22 must be slightly modified to provide the correct output waveform to properly drive an external RF amplifier. If you specified it at the time you ordered your SSQ-2F v3.22, the modification will have already been made. This modification may be easily reversed should you ever wish to do so.

This modification is NOT needed when the PA1 amplifier is used.

The SSQ-2F v3.22 may also be used as a contact device driver by building a simple adapter circuit.

The diagrams on the next page show how the SSQ-2F is interconnected in typical Rife-type systems.

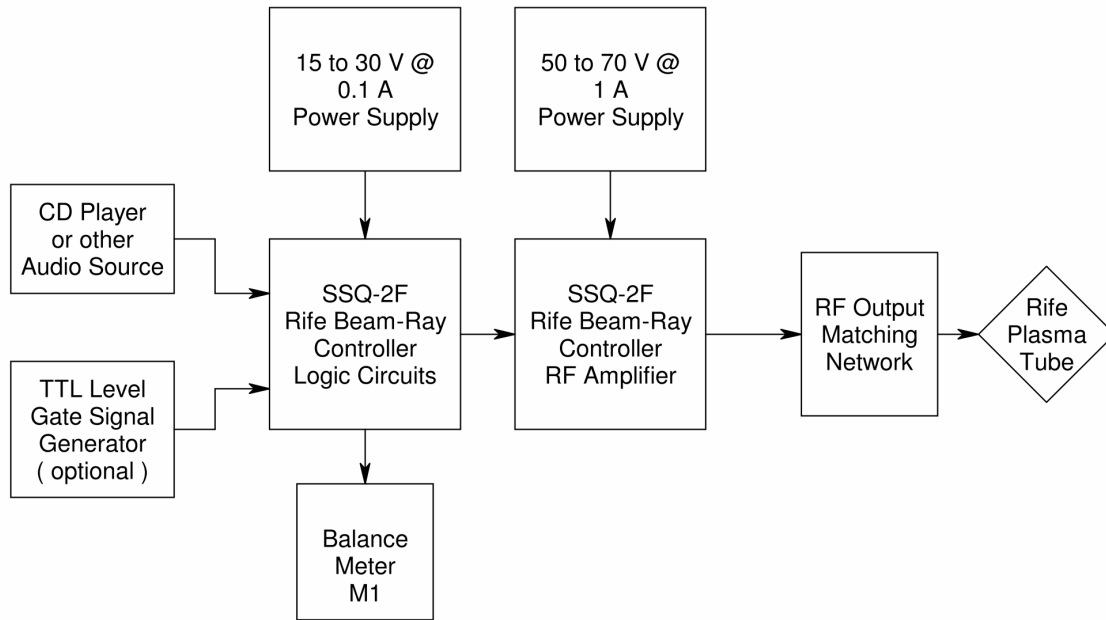

Figure 1

Block diagram of a typical Rife plasma system using the SSQ-2F v3.22.

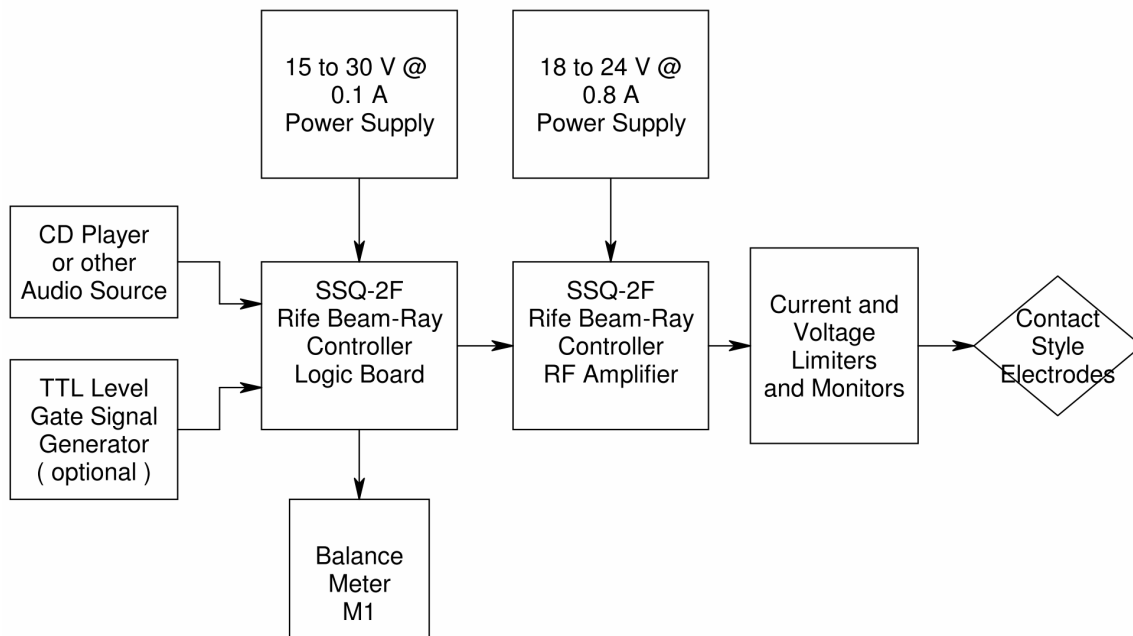

Figure 2

Block diagram of a typical Rife Contact System using the SSQ-2F v3.22.

CONNECTIONS:

All connections to the SSQ-2F are made by using the small screw terminals that are located in the plastic terminal blocks mounted on the edges of the circuit board. These will accept either solid or stranded conductor wire.

When tightening the screws, do not over tighten the screws to avoid damaging the connector. Just strip about 1/4" of insulation off the end of each wire and insert it into the hole in the terminal block, then gently tighten the screw to clamp the wire in place.

This diagram shows the relative position of the various connectors on the SSQ-2F. They have been color coded for ease of identification. Note that the terminal blocks on the SSQ-2F itself will usually all be the same color.

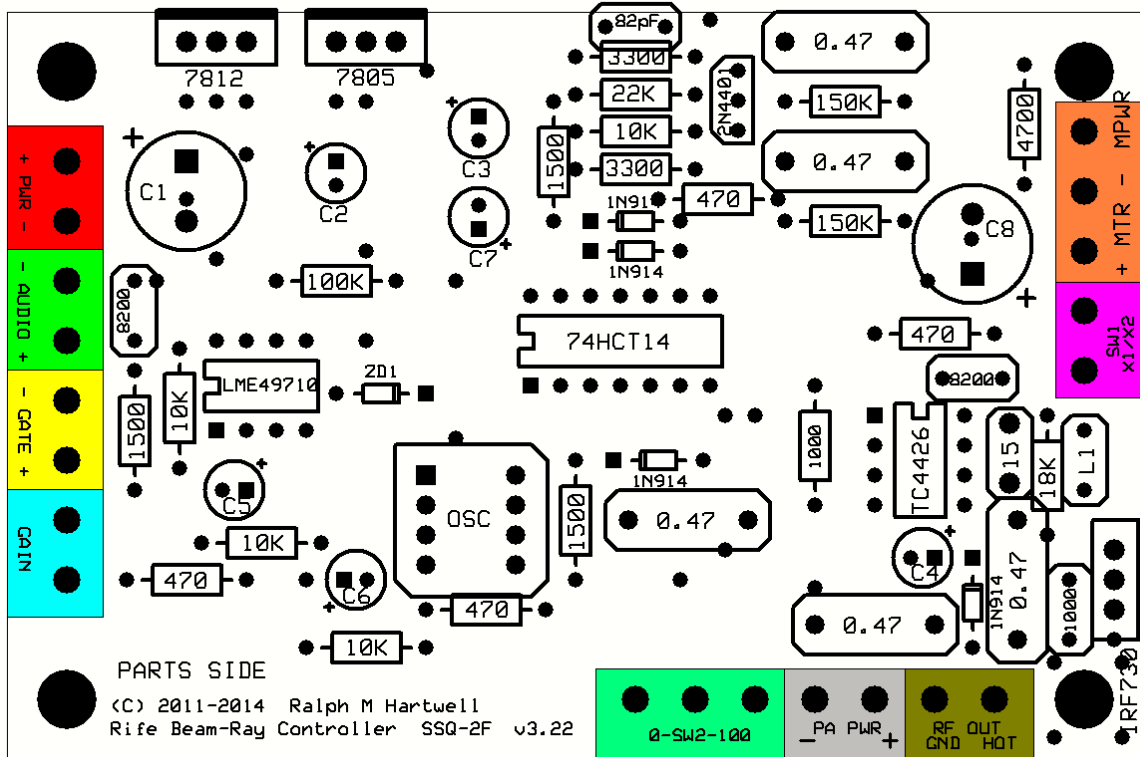

Figure 3

SSQ-2F Connector Identification.

Please refer to Figure 3 for the location of the following connections.

(+ PWR –)

This terminal block is used to connect DC power for the SSQ-2F. Any voltage between +15 to +30 volts may be used. Current required is 100 milliamperes.

(AUDIO IN)

Used to connect a shielded audio cable from the audio signal source to this connector.

Connect the cable shield to the connection closest to the PWR connector – this is the audio input cable ground connection. The shield wire for the shielded 2-wire cable connecting to the Audio Gain potentiometer R2 should also connect to this ground terminal.

Connect the center wire of the shielded audio cable to the connection closest to the GAIN connector – this is the audio input connection.

(GATE)

This accepts a TTL level gate frequency signal which will turn the output of the SSQ-2F on and off at the gate frequency rate. Gating frequencies from DC to approximately 500 Hz may be used.

If there is no connection made to this terminal block, the gate function is disabled, and the output of the SSQ-2F will only be controlled by the audio input signal connected to the AUDIO terminal block.

When the TTL level signal goes low (0 volts) the SSQ-2F output is gated OFF. When the TTL level goes high (greater than +3 volts) the SSQ-2F output is gated ON.

A SPST switch may be connected to the GATE terminal block. This switch may be used to turn the output of the SSQ-2F on and off at the operator's discretion.

(GAIN)

Leave these connections open to obtain the maximum audio gain from the SSQ-2F. (Lowest audio input voltage required.)

Short these connections together to obtain the lowest audio gain from the SSQ-2F. (Highest audio input voltage required.)

Using a length of 2-wire shielded audio cable and a 100 K ohm linear taper potentiometer, and connect the center (wiper) terminal of the potentiometer to either connection of the GAIN terminal block.

Connect one of the two outer terminals of the potentiometer to the other connection of the GAIN terminal block.

The shield wire for the shielded 2-wire cable connecting to the Audio Gain potentiometer R2 should be connected to the ground connection of the AUDIO terminal block.

If desired, a ¼ watt, fixed resistor (of a value selected by the user) may be installed instead of the potentiometer. This resistor will reduce set the maximum audio input voltage that the SSQ-2 will accept.

(0-SW2-100)

Connect a single pole, double throw (SPDT) switch to this connector block.

The center arm of the switch goes to the center connection of the terminal block.

The two outer connections of the switch go to the two outer connections of the terminal block.

When the left (0) and center connections are closed, the SSQ-2F will operate in the 0 to 50% duty cycle mode.

When the right (100)and center connections are closed, the SSQ-2F will operate in the 50% to 100% duty cycle mode.

(- PA PWR +)

Connect the NEGATIVE (-) side of the RF amplifier power supply to the (-) connection of the PA PWR terminal block. Connect the POSITIVE (+) side of the RF amplifier power supply to the (+) connection of the PA PWR terminal block.

Note that the negative (-) connections of the PA PWR and the logic PWR terminal blocks are common, that is, they are connected together inside the circuit board..

(RF OUT)

This terminal block is where the RF output of the SSQ-2F appears. Connection to this block requires the use of a shielded 50-ohm impedance coaxial cable between the terminal block and the matching system that will be connected to the plasma tube or the external RF amplifier (if used.)

If the SSQ-2F is to be used as a contact device, then a shielded 50-ohm impedance RF coaxial cable must be run from this terminal block to the shielded enclosure that houses the circuits that will feed the contact electrodes.

Connect the center wire of the coaxial cable to the connection of the RF OUT terminal block that is closest to the lower right side mounting hole of the board.

Connect the shield of the coaxial cable to the connection of the RF OUT terminal block that is closest to the PA PWR terminal block.

(SW1 - X1/X2)

Connect a single pole, single throw (SPST) switch to this connector block.

This switch allows operation in either the X2 mode (switch open) or the X1 mode (switch closed.)

(MTR)

There are three connections on the MTR terminal block.

Connect the duty cycle meter type M1-D to the MTR terminal block.

The **BLACK** negative ground wire from the M1-D meter connects to the **center** connection of the MTR terminal block.

The solder side of the SSQ -2F circuit board is marked “- MTR“ for this connection.

The **WHITE** duty cycle signal wire from the M1-D meter connects to the **left** connection of the MTR terminal block

The solder side of the SSQ -2F circuit board is marked “+ MTR” for this connection.

The **RED** meter power supply wire from the M1-D meter connects to the **right** connection of the MTR terminal block.

The solder side of the SSQ -2F circuit board is marked “MPWR” for this connection.

CAUTION: Accidentally connecting either the black or the white wire to the MPWR terminal will destroy the meter.

If you are using a high impedance voltmeter instead of duty cycle meter M1-D, then you should connect a fixed resistor with a value between 500 and 2200 ohms across the MTR terminal block connections to allow proper meter response time while making duty cycle adjustments.

You may use the earlier type M1-A analog duty cycle meter by replacing resistor R4 with a 3000 Ohm resistor.

Mounting the SSQ-2F

NOTE: The SSQ-2F v3.22 is much less sensitive to RF feedback than earlier versions of the SSQ-2F. Because of this reduced sensitivity it may not be necessary to use the shielding system that is described on the following pages. However, that information is included here both for completeness, and for assistance in problem solving should you encounter RF feedback with your SSQ-2F circuit board.

The SSQ-2F should be mounted in a metal or plastic enclosure. If the SSQ-2F is mounted in a plastic enclosure, it should be mounted over a metal shield plate with dimensions of approximately 12 x 15 cm in size. This is required to prevent RF feedback when the unit is run at high power levels.

Four mounting holes located in the corners of the SSQ-2F are provided for mounting the board. If the SSQ-2F is mounted next to a metal surface, then the use of 6 mm diameter standoffs is suggested to prevent unwanted short circuits between the underside of the SSQ-2F and the metal mounting surface. Either metal or plastic spacers may be used.

Clearance has been provided between the outer edges of the mounting holes and the SSQ-2F circuit board traces to allow the use of metal standoffs of up to approximately 9 mm in diameter. It is not necessary to use all four mounting holes. Be careful that the mounting hardware does not cause short circuits on either side of the circuit board.

It is essential that proper grounding procedures be used when installing the SSQ-2F to prevent RF feedback from affecting the audio processing circuits. When mounting the SSQ-2F, install a short length of wire between the negative (-) pins on both of the PWR and MTR terminal blocks and the metal ground plate. These will help keep unwanted RF interference from entering the circuitry of the SSQ-2F.

Note that the mounting hole nearest to the IRF730 is connected to circuit and RF ground. If the SSQ-2F is mounted on a metal chassis or support, it is recommended that this mounting hole be connected to the metal chassis or support structure.

Due to the sensitivity of the audio processing circuits of the SSQ-2F, and depending on your particular system layout, it may be necessary to add a metal shield to the SSQ-2F to eliminate signal jitter when operating the SSQ-2F at power levels above 50 watts.

The shield may be constructed of any type of thin sheet metal such as aluminum or tin and bent to an "L" shape as shown in the picture below. The shield should be grounded by connecting three corners of the shield to the mounting screws that attach the SSQ-2F to the lower shield plate.

If the shield is not installed when operating at RF amplifier with DC supply voltages above 48 volts, it is possible for the modulated RF output will be erratic and exhibit time jitter. This is due to RF energy getting back into the audio processing circuits. Use of the shield will eliminate this problem. This time jitter causes the desired harmonic energy in the RF output to shift back and forth slightly in phase and amplitude. However, this will not harm the SSQ-2F, but it more difficult to view the signal on an oscilloscope. Information on the following pages will give you an example of a suitable show shield design and placement.

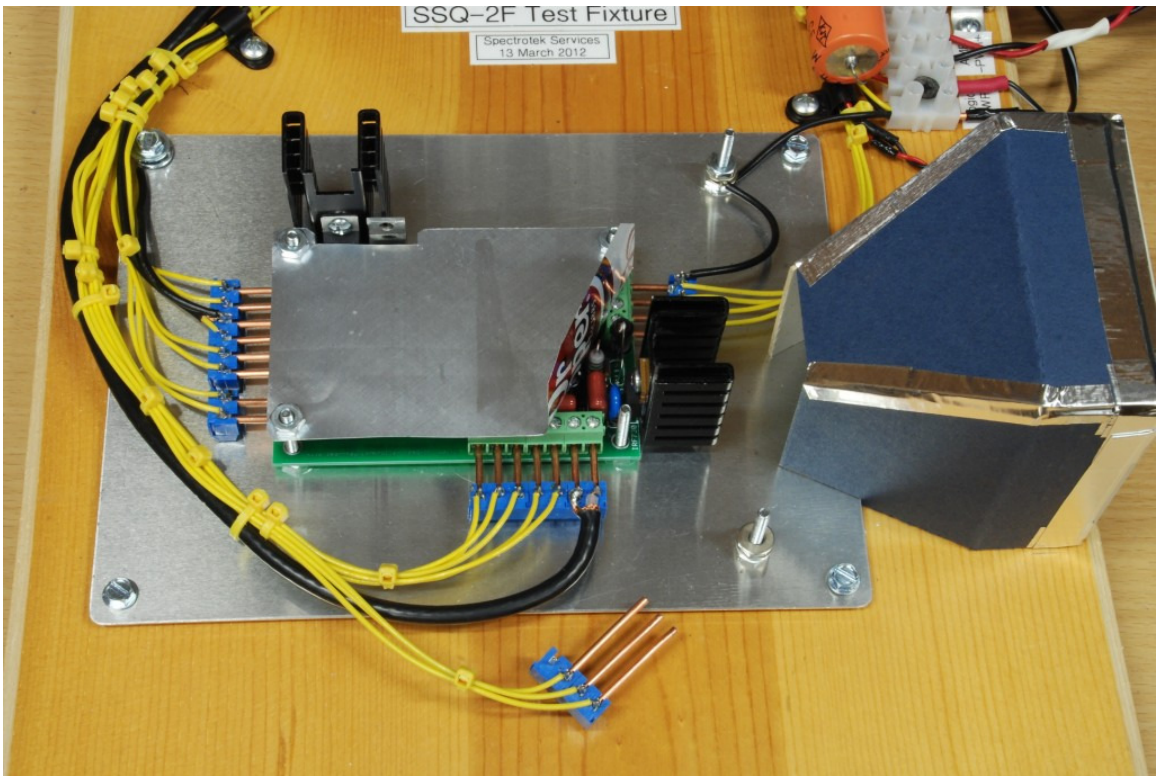

Figure 4.

This picture shows the SSQ-2F v3.22 mounted in the production test fixture. The shield over the SSQ-2F is constructed from a soft drink can.

The shield under the SSQ-2F holds the four mounting screws for the SSQ-2F. The SSQ-2F is not bolted down firmly during the test procedures. However, the upper shield is grounded to the lower shield by three of the four mounting bolts.

The copper probes are quick connectors so that the unit under test may be quickly changed as needed.

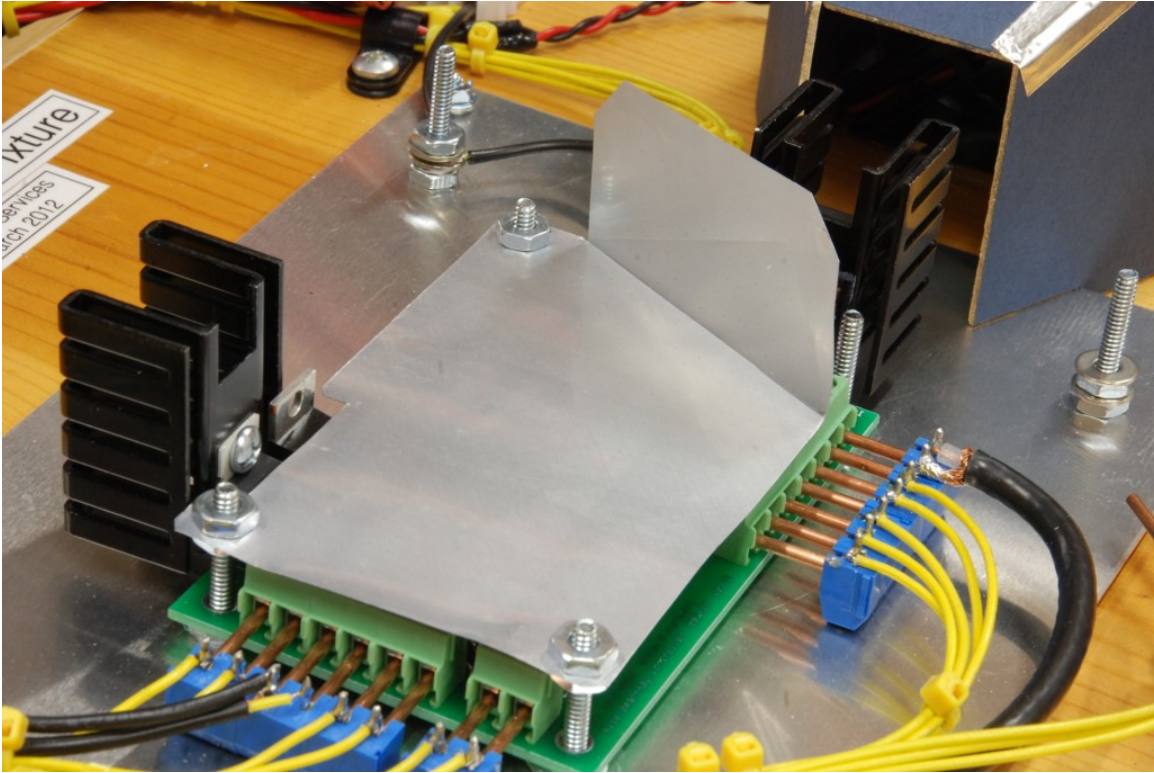

Figure 5.

This view shows how the shield is bent at right angles. The vertical portion of the shield prevents the electric field from the IRF730 from being “seen” by the rest of the circuitry on the SSQ-2F.

The upper RF shield is grounded to the lower shield by three of the four mounting screws. The sharp corners of the upper RF shield have been trimmed at a 45-degree angle to prevent injury to the operator.

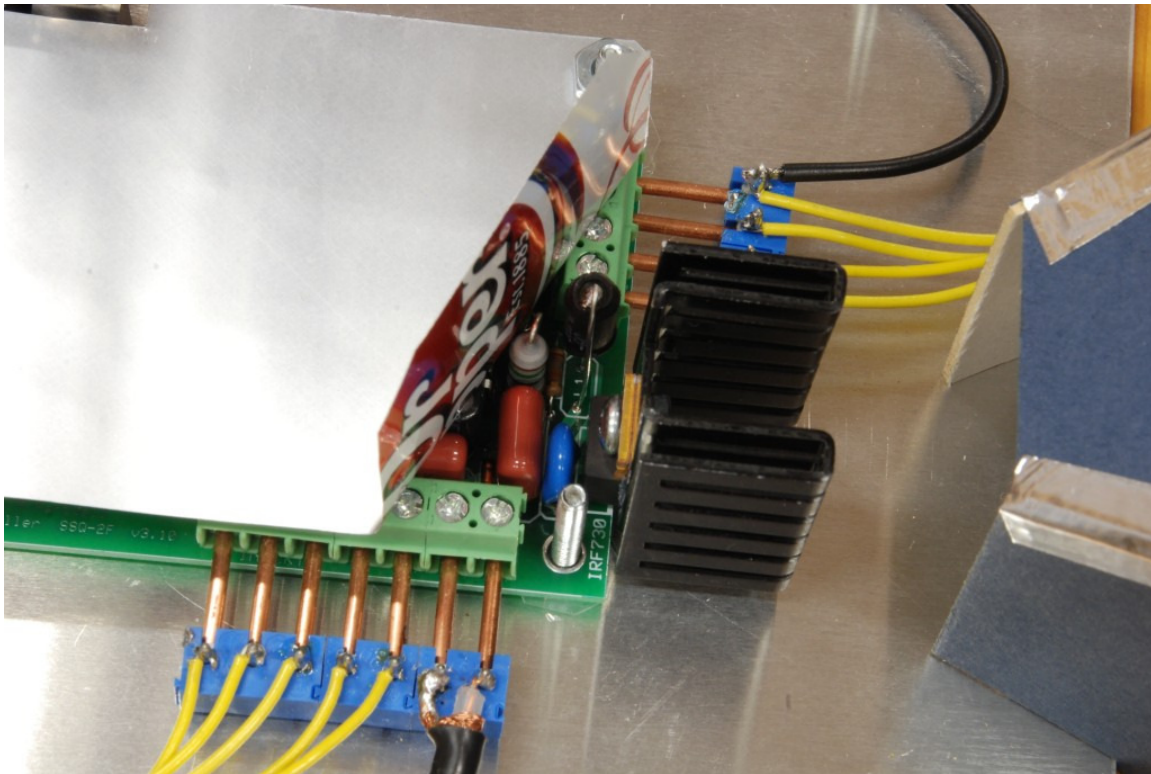

Figure 6.

This view shows that the shield really was made from a soft drink can! The RF shield just has to be electrically conductive; it does not have to be thick.

The shield must be bent so that it does not come in contact with the gray colored gate drive limit resistor which can be seen directly above the brown capacitor in the center of the photo.

Angling the shield in this direction allows the warm air to flow freely away from the heat sink. It also allows some cooling air to flow under the shield to cool the TC4426 gate driver IC.

Due to space limitations, you will probably not be able to install a nut on the mounting screw next to the IRF730 heat sink. That's OK using just two out of the four mounting points is sufficient. Please be sure you do not to allow the mounting hardware to short circuit anything under the circuit board when you clamp it down.

SSQ-2F v3.10 RF Shield
Spectrotek Services
March 16, 2012

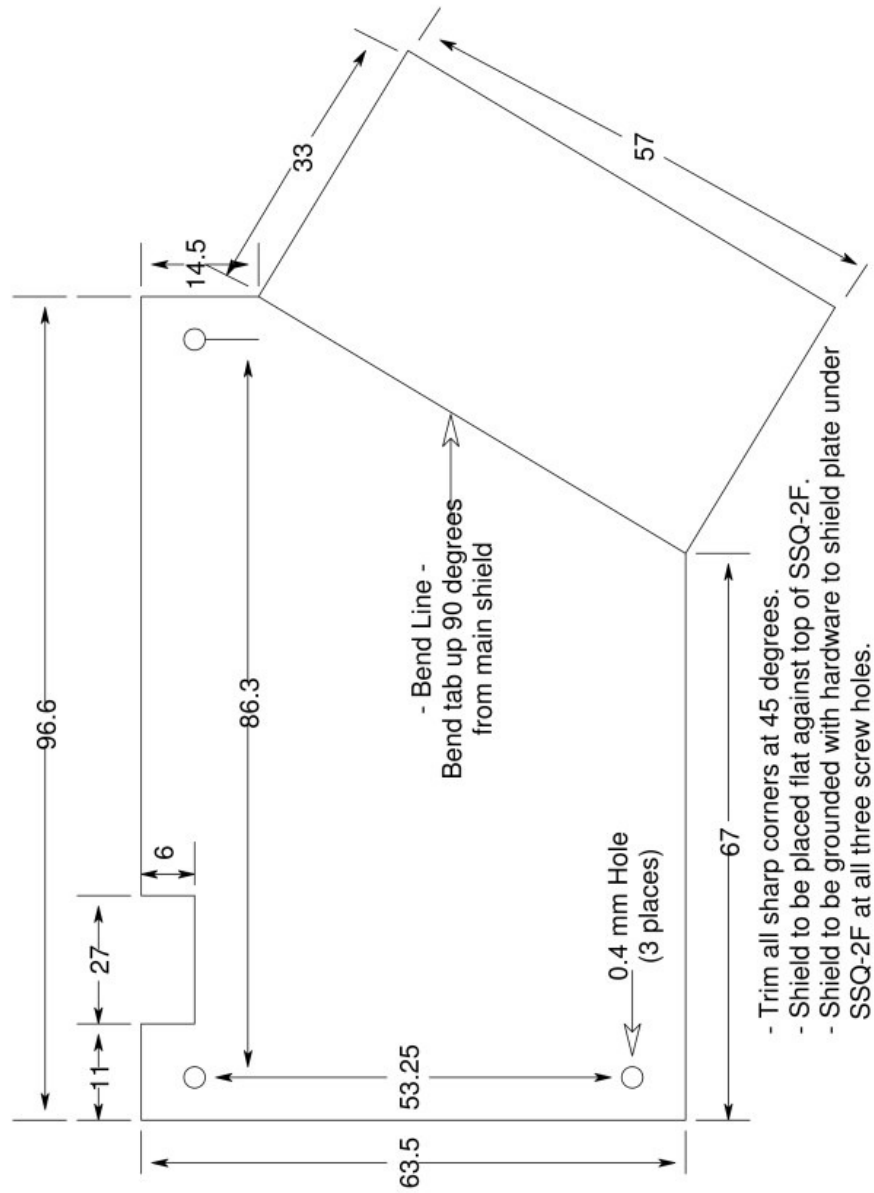

Figure 7.

Plan layout of the RF shield for the SSQ-2F v3.22.

Not to scale. All dimensions in millimeters.

RF Shielding Considerations to Prevent Interference to Other Devices

Provided that the RF output of the SSQ-2F is taken through a properly installed and terminated coaxial cable or twisted pair of wires, the incidental RF leakage from the SSQ-2F is minimal and no interference to radios or television receivers should occur due to radiation from the SSQ-2F itself.

However, it is very important to prevent outside RF energy, such as from an operating plasma tube, from entering the SSQ-2F. Unwanted RF ingress will cause erratic operation and incorrect modulation of the RF carrier.

The most common point of entry for unwanted RF energy is via the audio input cable. Using a shielded audio cable is a must. Make sure the cable is routed well away from the high-power RF components of the system. Use the shortest length of audio cable possible.

In severe cases of interference, looping the audio cable a half-dozen times through a ferrite toroid will usually eliminate the problem. Place the toroid as close to the input connections of the SSQ-2F as possible. Use a toroid core with material type 31 for best results.

A second cause of RF ingress is direct pickup by the circuit board traces of the SSQ-2F. Normally, this will only occur in cases where the ambient RF field is extremely high due to incorrect equipment placement.

To prevent this problem, it is suggested that a metal case be used to house the SSQ-2F. If this is not possible, then mount the SSQ-2F on a metal panel about 15 x 18 cm in size.

Another option when using a plastic case is to install a metal plate inside the case to which the SSQ-2F is mounted. The metal plate should be connected with a short lead to the ground terminal of the PWR and MTR terminal blocks of the SSQ-2F.

If a metal plate is not available, a layer of aluminum foil may be glued to the inside of the plastic case to act as shielding. Make sure the foil is well glued so it does not come loose at a later time and cause a short circuit against the traces on the underside of the SSQ-2F. The metal foil should be connected with a short lead to the ground terminal of the PWR and MTR terminal blocks of the SSQ-2F.

Heat Sink – Voltage Regulator

Although it is recommended that the heat sink be used at all times, if absolutely necessary, it may be removed to save space when mounting the SSQ-2F in a small enclosure. If this is done, the DC power supply voltage must be limited to no more than 19 volts to prevent overheating of the 7812 +12 volt regulator. If the heat sink is removed, then the SSQ-2F should not be used to power the cooling fan on the PA1 amplifier.

If the DC power supply voltage is above 19 volts, the heat sink **MUST** be attached to the 7812 +12 volt regulator to prevent overheating and possible failure of the regulator, particularly if the SSQ-2F is supplying 12 volts DC to the cooling fan of the PA1 amplifier.

The preferred mounting position of the heat sink is such that cooling air will flow across the long dimension of the heat sink. If necessary, the heat sink may be rotated to either the horizontal or the vertical position, depending on how the SSQ-2F is mounted. The 7805 +5 volt regulator does not require a heat sink. Since both of the metal backs of the voltage regulators are connected to circuit ground, it does not matter whether or not the heat sink on the 7812 +12 volt regulator touches the 7805 +5 volt voltage regulator.

The heat sink attached to the 7812 +12 volt regulator is connected to electrical ground on the circuit board.

Heat Sink and Cooling the IRF730 RF Output Amplifier

Caution – The heat sink is directly connected to the drain of the IRF730. This means that the heat sink is connected to the hot (+) side of the PA PWR power supply. Accidentally shorting the heat sink to ground may damage the SSQ-2F and/or your power supply.

The IRF730 MOSFET, which is used as the RF power amplifier in the SSQ-2F v3.22, is a rugged device. However as with all semiconductor devices, excessive heat will cause failure. Evidence of IRF730 failure will depend on the type of power supply you have connected to the PA PWR terminal block.

If the supply is current limited, then the failure of the IRF730 will be quiet; the RF output will simply drop to zero. However, if you have a “stiff” power supply that can supply a large amount of current, the IRF730 may fail in a more spectacular manner, such as emitting smoke or bursting into flame or even exploding like a firecracker. Obviously, we do not want any failures!

As supplied, the IRF730 and the LM7812 voltage regulator both have the same type of heat sink. This heat sink is adequate in size for the IRF730 as long as the following two conditions are met.

First, the heat sink must be freely exposed to room temperature air of no more than 38° C. Second, the PA PWR voltage should be no greater than 24 volts DC. This will provide about 12.5 RF watts output.

Because most uses for the SSQ-2F v3.22 will be in applications requiring substantially more RF output than 12.5 watts, improved cooling of the IRF730 is necessary. The easiest way to do this is by using a fan to force cooling air over the heat sink.

For most power levels, if the ambient air temperature does not exceed 30° C, a suitable cooling fan can be a high-speed computer case fan that is fitted with a cardboard shroud to concentrate and direct the cooling air over the heat sink. (See Figure 4.) It is essential to cool the entire heat sink, not just the fins; otherwise a “hot spot” may develop at the point where the IRF730 is attached to the heat sink.

The fan seen in figure 4 is an 80 mm x 25 mm, 12 volt, 0.30 ampere fan. It spins at about 4000 RPM. It is arranged to blow the cooling air directly against the center of the heat sink, forcing the air to impinge on the area where the IRF730 is mounted. A small centrifugal fan would also work well. The general rule is, you cannot have too much cooling air! Using this arrangement, the SSQ-2F works nicely up to a power output of 100 watts peak, 50 watts average power, at a 50% duty cycle modulation.

For higher power operation, it is strongly recommended that the supplied heat sink be removed and a much larger heat sink be installed. Because standard insulated thermal pads for transistors have a fairly high resistance to heat flow, it will be necessary to mount the IRF730 directly to the bare metal of the heat sink. This means the heat sink will be electrically “hot” with both DC and RF. Therefore, suitable electrical insulation of the heat sink must be provided.

If convenient, it is acceptable to remount the IRF730 so that it is parallel to the circuit board of the SSQ-2F in order to attach the IRF730 to a heat sink. Note that it may be necessary to unsolder the IRF730 from the heat sink in order to mount it flat, as the leads are rather short. If specified at the time of order, the leads will be left at the correct length for horizontal mounting of the IRF730.

Removing and Reattaching the Heat Sink of the IRF730

If the heat sink is removed from the IRF730, heat sink thermal compound must be used between the transistor and the heat sink when reattaching the original heat sink or installing a replacement heat sink on the IRF730.

Failure to use heat sink thermal compound may cause the IRF730 to fail due to overheating. In addition, the IRF730 must be mounted directly against the heat sink without the use of a thermal pad, as use of a thermal pad may cause overheating due to lowered heat transfer from the transistor to the heat sink.

Anodized aluminum thermal pads are marginally acceptable. However, when using these pads, the temperature of the IRF730 must be monitored to ensure that overheating does not occur during high power operation.

Metering the Square Wave Duty Cycle

Please refer to the section of this manual titled “CONNECTIONS” for information about connecting the M1-D duty cycle meter to your SSQ-2F.

Should you choose to use your own meter, it will be necessary to calibrate it to read correctly with your SSQ-2F. The metering circuitry of the SSQ-2F has been designed to operate correctly with the M1-D meter, or, after changing a resistor on the SSQ-2F board, with the analog M1-A duty cycle meter which has a 2 Milliampere full-scale movement.

Although the type M1-D meter is furnished pre-calibrated, it is advisable to do a field calibration of the meter to your particular SSQ-2F v3.22. This ensures the utmost accuracy when measuring the duty cycle of the modulated RF output of the SSQ-2F v3.22.

To calibrate your M1-D duty cycle meter, apply DC power to the PWR terminal block of the SSQ-2F. Do not apply any DC power to the PA PWR terminal block of the SSQ-2F. This procedure will allow the logic circuits and the audio processing circuits of the SSQ-2F to operate, but the SSQ-2F will produce any RF output. RF output is not required to adjust the duty cycle meter M1-D.

With DC power applied to the PWR terminal block, and with no audio input (zero voltage) to the AUDIO terminal block of the SSQ-2F, meter M1-D should read zero.

As you increase the audio voltage input to the SSQ-2F, the M1-D meter will begin to indicate an increasing reading. Continue to raise the audio voltage input to the SSQ-2F until the meter reading stops increasing. This should be somewhere close to a reading of 100.

If the meter reading is not exactly 100, then carefully adjust the calibration potentiometer that is located on the back of the M1-D meter until the meter displays a reading of 100.

This completes the calibration of the M1-D duty cycle meter to your SSQ-2F v3.22.

It is possible to make your own analog duty cycle meter by connecting a 500 ohm potentiometer across the (+) and (-) MTR terminals. Connect a 100 microampere meter from the (-) MTR connection to the center connection (wiper) of the potentiometer. Calibrate your analog meter by following the calibration instructions (above) for the M1D meter.

General Operation of the SSQ-2F v3.22

Power Supply

To use the SSQ-2F, you will need to connect a power supply of between +15 to +30 volts DC to the PWR terminal block. This provides power for the logic circuits of the SSQ-2F. The current required by the logic circuits is 0.1 amperes maximum.

NOTE: If the SSQ-2F v3.22 is being used to drive the PA1 amplifier, then the DC voltage connected to both the PWR and the PA PWR terminal blocks must be within the range of 19 to 24 volts. The DC current required will be 0.8 Amperes, maximum. Do not exceed 24 volts on the PA PWR terminal block or the PA1 amplifier may be damaged.

You will also need to provide a power supply for the RF amplifier section of the SSQ-2F. This supply connects to the PA PWR terminal block. It is advisable to make provisions to switch this power supply on and off separately from the logic power supply.

NOTE: It is recommended that you connect an electrolytic capacitor of at least 1000 uF with a voltage rating of 75 volts DC or higher as close to the PA PWR terminal block as possible. This will help avoid power supply “bounce” and ripple in the RF output waveform that is caused when the RF amplifier section of the SSQ-2F draws pulses of current through the inductance of the wires from the power supply. This capacitor is NOT required when the SSQ-2F is connected to a PA1 amplifier.

The RF power output from the amplifier section is adjusted by varying the DC supply voltage connected to the PA PWR terminal block.

If you are using the SSQ-2F to drive a plasma tube without using an external solid state RF amplifier, or using it to drive an external vacuum tube amplifier, the maximum voltage for the PA PWR connection should be limited to 80 volts. Forced air cooling of the IRF730 heat sink will also be required.

If you are using the SSQ-2F to drive an external solid state RF amplifier other than the PA1, then the SSQ-2F must be modified by adding a low loss 2200 pF ceramic capacitor rated for 100 volts DC between the gate and source terminals of the IRF730 RF amplifier MOSFET. In addition, the maximum PA PWR voltage should be limited to 30 volts to prevent damage to the external power amplifier. The exact voltage required will depend on the drive power required by the external amplifier. Forced air cooling of the IRF730 heat sink may also be required.

If you are using the SSQ-2F to power a contact device, the PA PWR voltage may be adjusted as required. It is suggested that the PA PWR voltage be limited to a maximum of 24 volts DC. This supply voltage will produce an output voltage of about 60 volts AC at 3.1 MHz, depending on the load that is connected to the RF OUT terminal block of the SSQ-2F RF amplifier.

Audio Input Signal

Please do not exceed the maximum allowable input audio level voltage of + or - 12 volts peak to prevent damage to audio input amplifier U1. The audio signal may be offset by a maximum level of +6 or –6 volts DC without damaging input amplifier U1.

The SSQ-2F will ignore any DC offsets, as long as they are constant. A varying DC offset voltage will be interpreted by the SSQ-2F as a change in the audio input level and will result in a change in the modulation duty cycle.

You will need an audio signal source somewhere between 40 to 7,200 mV peak to peak. The audio signal must not change in amplitude as the frequency of the audio signal changes. Most computer sound cards will meet this requirement. Some CD and DVD players will not, but this can usually be remedied by placing a load resistor across the audio output of the CD or DVD player. The required resistance value will usually be within the range of 10 to 100 ohms.

In order to adjust the duty cycle of the modulated RF square wave output, it is necessary to be able to adjust the amplitude of the audio signal being sent to the SSQ-2F, either by adjusting the level at the source or by using potentiometer R2 which should be connected to the GAIN terminal block of the SSQ-2F.

If you wish to use a fixed resistance instead of a potentiometer to set the gain of the SSQ-2F, the following resistance values may be used as a starting point:

Resistance	Peak to Peak Volts
0 Ohms (jumper)	7.2 V / 7,200 mV
470 Ohms	3.8 V / 3,800 mV
4,700 Ohms	0.75 V / 750 mV
10,000 Ohms	0.375 V / 375 mV

Modes of Operation

The following figure shows the various operating modes of the SSQ-2F.

Type of Input Audio Signals	Sine, Triangle, Square*	Sine, Triangle
RF Carrier Output	Modulation Rate Equals Audio Frequency (X1 Mode)	Modulation Rate Twice Audio Frequency (X2 Mode)
0-50% Duty Cycle	Mode 1	Mode 2
50-100% Duty Cycle	Mode 3	Mode 4

* When using square wave input, only 50% duty cycle is available

Figure 8 – Operating Modes of the SSQ-2F

Selection between the operating modes is made by using jumper wires between the appropriate connections on the 0-SW2-100 or SW1 - X1/X2 terminal blocks. For convenience, switches may be connected to the terminal blocks to allow for instant mode selection as needed.

Operation with Square Wave Audio signals

When operating in Modes 1 or 3, with square wave audio signals, increasing the audio signal level excessively or turning the audio gain potentiometer R2 too high will result in an erratic square wave output.

The SSQ-2F determines when to turn the RF carrier on and off by sensing the rate of amplitude change of the input audio signal. While sine and triangle waves have smooth rise and fall times, square waves are very abrupt, and the SSQ-2F cannot do anything except sense the rising and falling edges of square waves. This means that using square waves as an audio input will cause the modulation signal from the SSQ-2F to follow the rising and falling edges of the square wave, but with much faster rise and fall times.

Because of this, the frequency-doubling mode of the SSQ-2F will not work with square wave audio input signals. The output will always be in the X1 Mode (Modes 1 & 3.)

NOTE: The duty cycle of the modulated RF output of the SSQ-2F will always follow the duty cycle of the input square wave signal.

If a square wave audio signal with other than a 50% duty cycle is sent to the input of the SSQ-2F, the polarity (and hence the duty cycle ratio) of the modulated RF output may be 0-SW2-100ed by reversing the connections to the 0-SW2-100 terminal block. This may be done either by using a jumper across the terminal block connections or by using a single pole double throw switch connected to the INV terminal block to change between the 0-50% and the 50-100% duty cycle settings.

For instance, if a square wave audio signal with a duty cycle of 80% is connected to the input of the SSQ-2F, the modulated RF output of the SSQ-2F will be ON for 80% of the modulation cycle and OFF for the remaining 20%. Reversing the connections to the 0-SW2-100 terminal block will result in the RF carrier being ON for 20% of the modulation cycle and OFF for the remaining 80%.

Driving an External Solid State RF Amplifier with the SSQ-2F

NOTE: This section does NOT apply when using the PA1 amplifier.

One of the uses of the SSQ-2F v3.22 is to serve as an exciter for a high power, external solid state RF amplifier. This is most commonly done when more power is required for driving a plasma tube than the SSQ-2F can supply on its own.

To properly drive a solid-state amplifier, the output waveform of the SSQ-2F must be modified slightly to obtain a more sinusoidal shape. This will provide a more balanced drive waveform for the external RF amplifier.

This modification may be accomplished in two ways. It may be added to the SSQ-2F by selecting the RF driver Capacitor option when the unit is ordered or it may be field installed by the user. The modification may be easily removed if and when the SSQ-2F is to be used for a different application.

The photo below shows the RF driver Capacitor installed on the SSQ-2F v3.22.

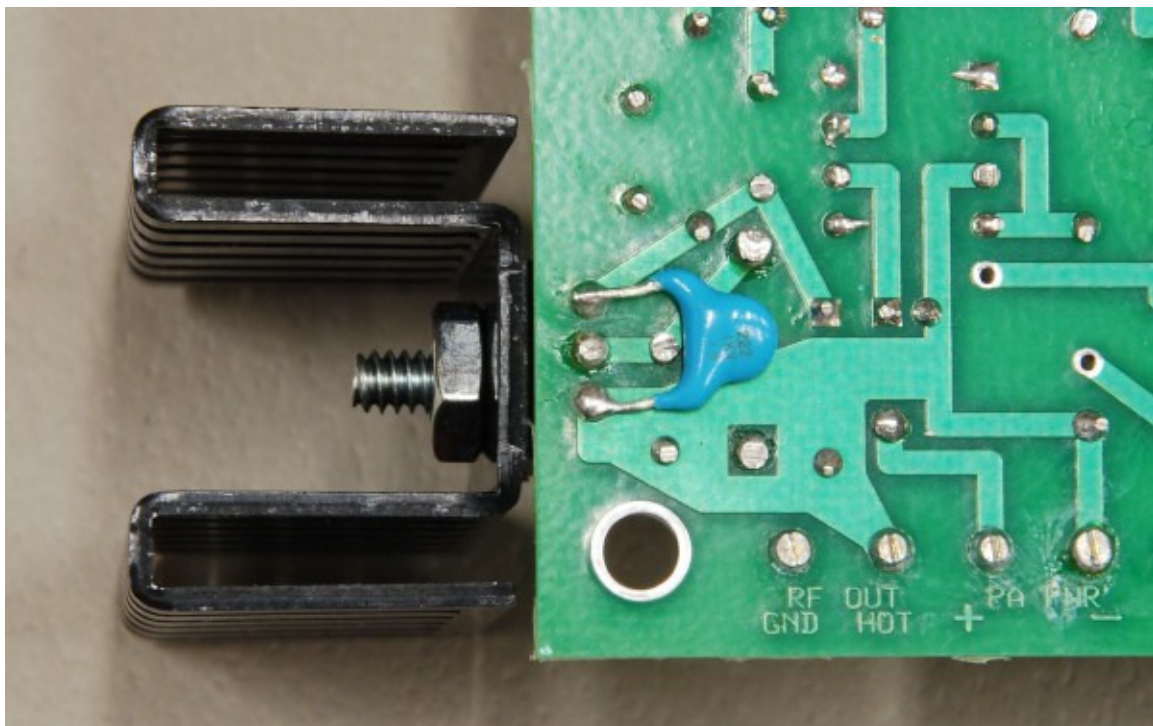

Figure 9

RF Driver Capacitor installed on SSQ-2F v3.22.

The capacitor should be a low-loss ceramic capacitor, 2200 pF and rated for 100 VDC.

If the RF drive capacitor is to be disconnected, this may be accomplished by unsoldering one end of the capacitor and bending the unsoldered lead slightly away from any other connections on the

circuit board. This will leave the capacitor still attached to the circuit board by one lead so that it will not become lost should you wish to reconnect it at a later time.

Setting the RF Drive Level From the SSQ-2F to the External Amplifier

NOTE: This section does NOT apply when using the PA1 amplifier.

When driving a solid state external RF amplifier, such as the KL-300 or the KL-500 series of amplifiers, it is important to limit the RF drive from the SSQ-2F that is sent to the external amplifier. Most of these amplifiers are designed to generate full power output with less than 15 watts of RF drive. Because the SSQ-2V can produce much more power than that, care must be taken not to overdrive the external amplifier and damage it. Remember that repairs can be expensive! Use the minimum power required for proper amplifier drive.

The addition of the RF drive capacitor modification to the SSQ-2F causes the output power of the SSQ-2F to be reduced considerably. In addition, it is necessary to lower the DC supply voltage that is connected to the PA PWR terminal block.

Most of the commercially available solid-state RF amplifiers are rated for a specific PEAK drive power, not AVERAGE drive power. Placing a standard RF wattmeter between the SSQ-2F and the RF input of the amplifier will give you an incorrect power reading. This is because most RF wattmeters are average reading devices and will only read correctly with a constant level, clean sine wave RF waveform.

The following figure shows the peak RF power output of the SSQ-2F v3.22 with the RF drive capacitor modification for various DC voltage inputs to the PA PWR terminal block:

PA PWR DC VOLTS	RF POWER OUT PEAK WATTS
+18	2.5
+24	5.0
+28	7.5
+36	12.5
+48	20.0

Figure 10

Due to the lower efficiency of the RF amplifier section of the SSQ-2F when the RF drive capacitor modification has been performed, the heat sink of the IRF730 MOSFET will become warmer than it would when it is operated at the same DC voltage as in the unmodified mode. It will be necessary to use forced air cooling of the IRF730 heat sink when using PA PWR DC supply voltages above 18 volts.

Turn On Caution When Using an External Solid-State RF Amplifier:

When first applying power to the SSQ-2F, the SSQ-2F may momentarily output a 100% carrier signal for about two seconds, even with no audio signal applied to the SSQ-2F. You will see the duty cycle meter M1 jump up from zero and then return to zero at power-on time. This is normal,

and is due to the capacitors in the SSQ-2F initially charging up to their normal voltage level. As soon as the capacitors are charged, the output of the SQ-2F returns to normal.

If the external RF power amplifier has power applied to it before the SSQ-2F is powered on, the initial burst of carrier may cause the power amplifier to fault or its power supply to shut down due to overloading. *For this reason, always turn on the SSQ-2F before you turn on the RF amplifier.*

Driving an External Vacuum Tube RF Amplifier with the SSQ-2F

The SSQ-2F v3.22 can provide enough RF power at 3.1 MHz to drive a vacuum tube amplifier. Because many vacuum tube amplifiers do not present a true 50-ohm load at their input connectors, it may be necessary to employ some form of impedance matching network between the SSQ-2F and the vacuum tube amplifier. This may be in the form of a low power antenna tuner.

The following figure shows the DC supply voltage and current requirements of the SSQ-2F RF amplifier section, and the peak RF power output that the SSQ-2F can supply.

PA PWR DC VOLTS	PA PWR DC AMPERES	PEAK RF WATTS OUTPUT @ 50 OHMS
15	0.2	3
20	0.3	7
24	0.35	10
28	0.4	16
30	0.45	20
36	0.5	25
40	0.6	35
48	0.7	50
50	0.75	53
60	0.8	75
70	1.1	100

Figure 11

Legend:

Green – Standard heat sink, no fan required.

Orange – Fan or larger heat sink required.

Red – Stronger fan and/or larger heat sink required. Disconnecting output cable during operation may cause MOSFET failure.

CAUTION ! ! Although the SSQ-2F is capable of operating at duty cycles up to 100%, unless a larger heat sink and/or vigorous forced air cooling of the heat sink is used for the IRF730, the use of modulation duty cycles above 70% is discouraged unless extreme care is taken.

Even with forced air cooling, heat cannot be removed from the IRF730 rapidly enough to prevent overheating at very high duty cycles when operating with DC supply voltages above 60 to 70 volts. Operation in ambient air temperatures above 25°C is not recommended.

When operating at high power levels and high duty cycles, it is necessary to monitor the temperature of the heat sink at the point where the IRF730 is bolted to the heat sink. The temperature of the heat sink should not be allowed to exceed a value of 71°C at the point of measurement. Failure of the IRF730 may be expected if the heat sink temperature is allowed to increase to 90° C or higher.

Connecting the SSQ-2F to the Vacuum Tube Amplifier

The connection of the SSQ-2F to the vacuum tube amplifier is straightforward. Simply connect a 50-ohm coaxial cable between the RF OUT terminal block of the SSQ-2F and the RF Input connector of the vacuum tube amplifier. If necessary, insert an impedance matching network or a small antenna tuner in the coaxial cable between the SSQ-2F and the amplifier.

Adjust the DC voltage connected to the PA PWR terminal block of the SSQ-2F for the desired grid drive on the vacuum tube amplifier. Adjust the impedance matching network for the lowest VSWR as seen by the SSQ-2F. This will normally correspond to the point of maximum grid drive on the vacuum tube amplifier.

Be sure to have sufficient forced air cooling on the heat sink of the IRF730. If the VSWR between the SSQ-2F and the input of the vacuum tube amplifier is excessive, the IRF730 may overheat excessively and be damaged.

Driving a Plasma Tube from the SSQ-2F Without an RF Amplifier

About Plasma Tubes

Because the SSQ-2F v3.22 can provide RF power levels of up to 100 watts peak power, it is possible to drive a moderate sized plasma tube from the SSQ-2F without the need for an external RF amplifier, however some form of coupling or matching system will be needed to match the 50 ohm output impedance of the SQ-2F to the load presented by the plasma tube.

Plasma tubes are of two basic types – internal and external electrode tubes. Internal electrode tubes are easier to light up because their electrodes are in intimate contact with the gas in the tube. The drawback is that the electrodes tend to absorb a lot of power during operation and they may become extremely hot, even to the point of glowing red. Should this happen, the electrodes will begin to give off gas (outgas) and contaminate the gas mixture in the tube. This result is an off-color glow or outright failure of the tube to light up.

To solve this problem, many experimenters switched to external electrode tubes. An external electrode tube has some form of metallic electrode wrapped around the ends of the tube. These electrodes may be in the form of a wrap-around collar, a spring-looking wire wrap, or a piece of metal screen wrapped around the ends of the tube. These electrodes are connected to the source of RF energy, just as would be the electrodes of an internal electrode tube.

External electrodes transfer the RF power to the gas in the tube by capacitive action – an AC current can pass through a capacitor, but not a DC current. Because almost all Rife plasma tube systems use an RF (AC) carrier to drive the tube, external electrodes work quite well. They are limited in power handling only by the maximum power the tube walls can withstand without melting. Generally, well before that point is reached, the gas inside the tube will heat up enough so as to increase the pressure and cause the tube to lose color and become dimmer, alerting the operator to the fact that the tube is too hot. An external electrode tube can handle ten times or more the power that the same size internal electrode tube can withstand.

RF Coupling Systems

Commercial Antenna Tuners

To couple the RF energy from the SSQ-2F to the plasma tube, a commercial antenna tuner of some sort may be used. This has been the standard practice for many plasma tube system operators. However, because the SSQ-2F operates at 3.1 MHz instead of the more commonly used frequency of 27.120 MHz, an antenna tuner designed for Amateur Radio service is necessary. Most Amateur Radio antenna tuners will go down to 1.8 MHz. Due to the continuous duty operation of plasma tube systems, you should obtain a tuner that is rated for at least 300 watts. Tuners with less power handling ability may overheat, and they will deliver less useful power from the SSQ-2F to your plasma tube.

Suitable commercial antenna tuners include the MFJ-949E and the MFJ-969. Of the two, the MFJ-969 is the better choice. Because it is a larger tuner, its internal losses will be lower. It is capable of handling the output from a high power RF amplifier should you decide to add one to your system in the future.

If you are using a commercial antenna tuner, you simply connect one end of a length of 50-ohm coaxial cable to the RF OUT terminal block of the SSQ-2F. Connect the other end of the coaxial cable to the input of the antenna tuner, usually labeled “Transmitter.”

If the tuner has a balanced wire output, then it has an internal balun transformer. In this case, connect a pair of wires from the balanced wire terminals on the tuner to the electrodes of the plasma tube.

If the tuner has only coaxial cable antenna output connectors, then you will need to add an external balun. Connect the input of the balun transformer to the antenna output jacks of the tuner. Connect the output leads of the balun through a pair of wires to the electrodes of the plasma tube.

To prevent unwanted RF radiation, the wires leading to the plasma tube should be as short as possible and placed as close together as possible without shorting them together.

Start the initial tune up procedure with the SSQ-2F running at about 50 volts on the PA PWR terminal block. This is low enough to protect the IRF730 during the early stages of tuning. After tuning is complete, the DC voltage may be increased to the desired power level and the tuning touched up as needed.

3.1 MHz Link Coupler System

A lower loss and less expensive coupling system is a tuned tank coil link coupled matching system as seen at:

http://rife-beam-ray.com/3.1mhz_match/index.htm

This improved coupling system, known as the LC31 Link Coil Coupler System, is available in various configurations from Spectrotek Services, <http://rife-beam-ray.com>

Using this system eliminates most of the RF losses of the antenna tuner and gives the RF signal a sharper rise and fall time, resulting in a better, brighter plasma discharge.

Tuning the System to Resonance

Regardless of whether you use a commercial antenna tuner or a link coupling system, the tuning is the same. You want to tune for the lowest VSWR reading and the brightest glow in the tube. Usually these will be close to the same tuning position.

Leave the PA PWR supply turned off. Now, set the audio frequency to about 6000 Hz. Next, adjust the audio level to the SSQ-2F so that you have a reading of about 50% duty cycle. Increase the PA PWR voltage to about 40 to 50 volts. This will give you a fair amount of RF power output without too much danger of blowing out the IRF730.

Now adjust the antenna tuner or link coupler tuning for the lowest VSWR / brightest glow in the tube. These should pretty much coincide. If you have an oscilloscope, you can “tweak” the tuning by observing the RF waveform at the RF OUT terminal block.

Tuning Waveforms

These pictures show the RF waveform at the RF output of the SSQ-2F. They are taken at TP3, the RF OUT terminal block. For these pictures, the SSQ-2F was connected to a plasma tube through the 3.1 MHz link coupler.

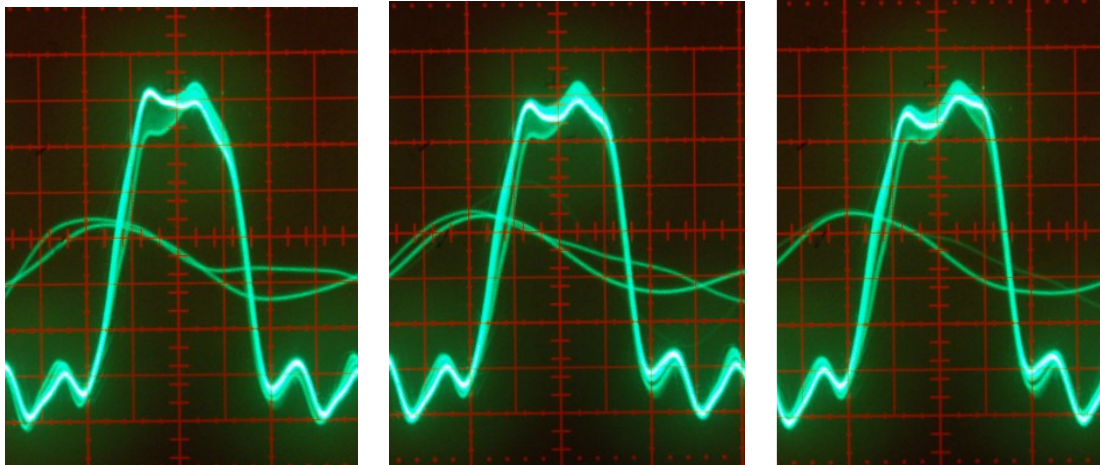

Tuned Low

Correct

Tuned High

Figure 12

Ignore the haze around the brightest part of the waveforms. Look at the double peak in the top of each wave.

The center picture shows what the waveform looks like at the point of lowest VSWR. This is also the point of the brightest glow in the plasma tube. Note that the two peaks in the waveform are of equal height.

The left picture shows what the waveform looks like when the tuning is set too LOW in frequency. This indicates that too much tuning capacity is being used. Note that the left peak is higher than the right peak. In this condition, the tube is dimmer than it should be, and the IRF730 is drawing less current than it does when the system is correctly tuned.

The right picture shows what the waveform looks like when the tuning is set too HIGH in frequency. This indicates that too little tuning capacity is being used. Note that the right peak is higher than the left peak. In this condition the tube is dimmer than it should be, and the IRF730 is drawing more current than it does when the system is correctly tuned. This extra current goes directly to losses and creates extra heat in the IRF730.

Due to the change in electrical characteristics of the ionized gas column in the plasma tube, you will find that as the RF power is increased through the tube, and the tuning will shift downwards in frequency. That means that if you do your initial system tuning at a lower power level than you will use in normal operation, you will need to retune and reduce the tuning capacity when you go to full power. You will also find that a hot tube will tune slightly differently than a cold tube. This is normal, and is caused by the change internal gas pressure that occurs as the gas heats up from the electrical current passing through the tube.

Driving an Contact System with the SSQ-2F v3.22

While the SSQ-2F v3.22 was not specifically designed for use as a contact device driver, it can be used for such service. Because the SSQ-2F v3.22 is designed to have a high RF power output, it must be used with care or damage to the unit and/or personal injury may result from radio frequency burns.

Spectrotek Services and Ralph M. Hartwell ARE NOT RESPONSIBLE for any damage or injuries of any sort or form that may be sustained by any person or persons, any animal, or to any equipment or any other thing or things while anyone is using, modifying testing or experimenting with the SSQ-2F in any manner whatsoever.

Using the SSQ-2F is done solely at your own risk.

The SSQ-2F v3.22 may be used as a voltage source for a contact device by reducing the output power of the RF amplifier and adding an external adapter.

Is necessary to reduce the voltage applied to the RF amplifier PWR terminal block to a lower voltage than is normally used. The DC voltage required to power the amplifier section of the SSQ-2F v3.10 will depend upon the RF output voltage you wish to achieve.

If a DC supply voltage of +19 volts is applied to the PWR terminal block on the SSQ-2F v3.10 an RF output voltage of approximately 45 to 50 V will be output on the RF OUT terminal block.

If the DC supply voltage of +38 V is applied to the PWR terminal block of the SSQ-2F v3.10 an RF output voltage of approximately 90 to 100 V will be output on the RF OUT terminal block.

In order to achieve a rapidly rising RF pulse is necessary to have the correct load resistance across the RF output of the SSQ-2F v3.10. Without a plasma tube connected to the SSQ-2F v3.10 we must replace the load of the tube with a set of resistors, which will absorb the RF power. This device is commonly called a "Dummy Load."

Connecting the terminals of the dummy load resistor across the RF OUT terminal block of the SSQ-2F v3.10 provides the proper load resistance from the SSQ-2F v3.10, maintains the correct waveform, and stabilizes the output voltage during operation.

Such a dummy load may be obtained commercially from companies such as MFJ, or you may construct one yourself. The dummy load must be capable of dissipating a continuous power of 20 watts.

The schematic diagram on the following page shows a typical dummy load and contact adapter for the SSQ-2F v3.22.

Contact Device Adapter
 for SSQ-2F v3.10
 Copyright (c) 2012 by Ralph M. Hartwell II
 V1.01 14 July 2012

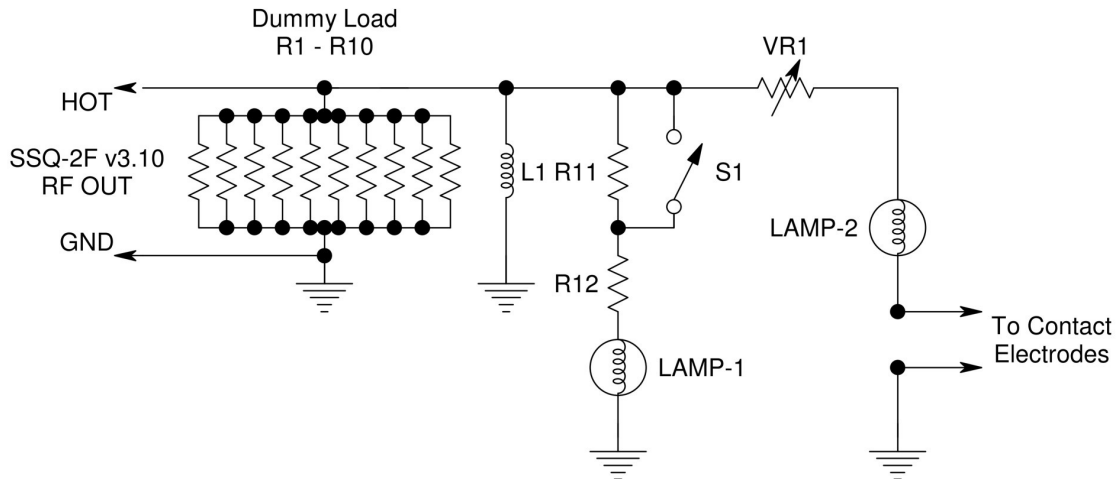

Notes:

+19 V on the SSQ-2F v3.10 RF amplifier PWR input results in 50 V RF output.
 +38 V on the SSQ-2F v3.10 RF amplifier PWR input results in 100 V RF output.

L1 - 4.7 uHy ferrite core inductor

R1 - R10 - 510 ohm 2 W 5% metal film resistor, Yageo RSF200JP-73-510R
 1) SPACE RESISTORS 5 MM APART AND ALLOW PLENTY OF COOLING AIR.

R11 - 270 ohm 1 W 5% metal film resistor, Yageo RSF100JB-73-270R

R12 - 150 ohm 1 W 5% metal film resistor, Yageo FMP100JR-52-150R

S1 - SPST toggle switch.

1) Closed for SSQ-2F v3.10 RF amplifier voltage of +19 V. Open for +38 V.

VR1 - 10k linear potentiometer for current limiting.

LAMP-1, LAMP-2 - 12 V 60 mA panel lamp, RadioShack 272-337A (green) or 272-332 (red).

1) LAMP-1 indicates RF output present. Brightness varies with duty cycle.

2) LAMP-2 provides absolute current limit of 60 mA to Contact Electrodes.

3) LAMP-2 reduces Contact Electrodes voltage by 12 V at full brightness.

Figure 13

The dummy load may be placed in the same box as the rest of the components, however it will be necessary to provide plenty of cooling air for the dummy load, especially if the SSQ-2F v3.10 is

operated at +38 V applied to the RF PWR terminal block. Ideally, the dummy load should be assembled in a well ventilated metal enclosure. The remaining components, resistors, light bulbs, etc., may be assembled in either a plastic or metal enclosure.

Because you will not have a plasma tube connected to the output of the SSQ-2F v3.10 to tell you when the system is producing RF power, it is convenient to install a simple monitoring circuit consisting of a resistor and a small incandescent light bulb. This indicator network is connected directly across the RF output of the SSQ-2F v3.10.

The brightness of the bulb will vary depending upon the modulation duty cycle you are using. The higher the modulation duty cycle percentage, the brighter the lamp will be. The lamp chosen for this adapter requires 12 V at 60 mA for full brightness. Because it draws very little power, it does not load down the output of the SSQ-2F v3.10.

Some method of controlling the current going to the contact electrodes is necessary. This is conveniently provided by the use of a 10,000 ohm variable resistor that is placed in series with the RF output of the SSQ-2F v3.10 in the line with one of the electrodes.

Besides using a variable resistor for current adjustment, it is also advisable to install another lamp of the same type in series with the variable resistor and the contact electrodes. All of the RF current going to the electrodes will pass through this lamp. This lamp will normally be very dim or not visibly illuminated during normal operation. However, should the contact electrode current increase above approximately 20 mA, the lamp will begin to illuminate dimly.

Should a condition occur where the circuit through the contact electrodes begins to permit excessive current to flow, the lamp will illuminate brilliantly, indicating that something is wrong and needs to be corrected. The lamp will limit the current to slightly more than 60 mA in a worst-case situation. If the current increases beyond that point, the lamp will quickly burn out, opening the circuit and disconnecting the RF power from the contact electrodes.

This figure shows the peak RF output voltage available for different PA PWR input DC voltages when the SSQ-2F v3.22 is used as a contact device driver.

PA PWR DC VOLTS	PEAK RF VOLTS OUTPUT
15	38
18	47
20	51
24	61
28	72
30	77
36	92
48	123
50	129
56	143
60	160
70	176

Figure 14

As you can see from this table, the SSQ-2F is capable of producing dangerous RF voltages. It is strongly recommended that you do not use a DC supply voltage higher than necessary to avoid injury or damage.

Note that the RF output of the SSQ-2F v3.22 is AC and is referenced to the ground/earthed/negative side of the DC supply voltage for both of the voltages connected to the PWR and PA PWR terminal blocks. If galvanic isolation between the equipment and the subject is required, it will be necessary to use approved power supplies that are life safety rated.

SPECIFICATIONS:

DC Power Supply Input:

- SSQ-2F v3.22 Logic Circuits +15 to +30 volts DC maximum, filtered, but need not be regulated, at 0.1 Ampere, or 0.25 Ampere when supplying DC power to the cooling fan on the PA1 amplifier.
- SSQ-2F v3.22 RF amplifier +12 to +80 volts DC filtered and regulated at 1.5 amperes maximum, current required varies with power output and modulation duty cycle. Nominal current less than 1.0 Ampere for 70 watts output with 50% duty cycle modulation.

Input Audio Signal Waveform:

- Sine, triangle, or symmetrical square wave.

Modulation Modes:

- X1 Mode - The modulation frequency equals the input audio frequency using sine, triangle, or square waves.
- X2 Mode - The modulation frequency equals TWICE the input audio frequency using sine or triangle waves only.

Carrier Frequency:

- 3.1 (standard) or 3.3 MHz. Frequency to be specified at time of order. The carrier frequency may be changed by the user by replacing the plug-in oscillator module with a module of a different frequency.
- Customer requested frequencies in the range of 2.6 MHz to 3.8 MHz are available on special order.

RF Power Output:

- 1) When set up for driving a plasma tube or when used as an exciter for an external vacuum tube RF amplifier, the SSQ-2F will produce up to 100 watts peak power, 50 watts average power as measured across a 50-ohm load when the carrier is modulated by a 50% duty cycle square wave.
- 2) When operating as a driver for an external solid state RF amplifier, the SSQ-2F will produce up to 15 watts peak, 7.5 watts average power as measured across a 50 ohm load when the carrier is modulated by a 50% duty cycle square wave.
- 3) When operating as a driver for a contact system, the SSQ-2F will produce up to 72 volts.
- The RF output power in (1) and (2) and the RF output voltage in (3) are adjustable by varying the DC input power to the RF amplifier PA PWR terminal block.

Modulation Frequency Ranges – X2 Mode:

Input Audio Frequency Range in X2 Mode @ 40 - 7200 mV p/p input level with a Sine or Triangle Wave Input Signal:

- Low - 40 Hz.
- High - 30,000 Hz at maximum audio gain, or 60,000 Hz at minimum audio gain.
- This will square wave modulate the carrier over the range of 80 to 60,000 Hz or 80 to 120,000 Hz.

NOTE: In the X2 Mode, using a sine or triangle wave audio input, the output of the Controller Board will maintain a 50% duty cycle ratio to within 10% or less across the input frequency range of 40 to 30,000 Hz at maximum audio gain, or 40 to 60,000 Hz at minimum audio gain. This allows unattended operation of the equipment without the need for constant audio gain adjustments when using an audio sweep signal generated by a computer sound card. It is necessary to maintain a low source impedance and a constant voltage as the audio frequency changes during the sweep.

Modulation Frequency Ranges - X1 Mode:

Input Audio Frequency Range in X1 Mode, @ 50 - 7200 mV p/p Input Level with a Sine or Triangle Wave Input Signal:

- Low - 6 Hz.
 - High - 200,000.
 - This will square wave modulate the carrier over the range of 4 to 200,000 Hz.

 - Usable frequency range from 4 to 400,000 Hz with increased audio input level.
 - This will square wave modulate the carrier over the range of 4 to 400,000 Hz.
-

Modulation Frequency with a Square Wave input signal of 50 - 7200 mV p/p:

Note: *Square wave audio is usable in X1 Mode only, and a 50% duty cycle is output by the Controller Board.*

- Low - 75 Hz.
 - High - 200,000 Hz.
 - This will square wave modulate the carrier over the range of 75 to 200,000 Hz.

 - Usable frequency range from 50 to 600,000 Hz with increased audio input level.
 - This will square wave modulate the carrier over the range of 50 to 600,000 Hz.
-

Warranty

All our products carry a one (1) year warranty against manufacturing defects. Mechanical damage is not covered; i.e., you dropped it on the floor and then accidentally stepped on it. For warranty claims, you pay shipping to us; we pay shipping back to you.

Kits assembled by the purchaser are also have a one (1) year against component failure. Breakage or overheating damage from soldering of components during assembly is not covered under warranty.

Damage to the IRF730 MOSFET transistor due to over voltage operation or inadequate cooling is not covered under warranty.

For all warranty claims or equipment service, please contact us by email or telephone before returning equipment for service.

Out-of-Warranty repair service is at the rate of \$20/hour, with a maximum charge of \$50 per item, unless otherwise specified. Please contact us for additional pricing on custom repair services.

Contact us

Ralph Hartwell

Spectrotek Services

641 Sisson Road
Natchitoches, LA
71457-6743
USA

318-527-6766

ralph@spectrotek.com

<http://rife-beam-ray.com>

<http://rifebeamray.com>

<http://w5jgv.com/rife>

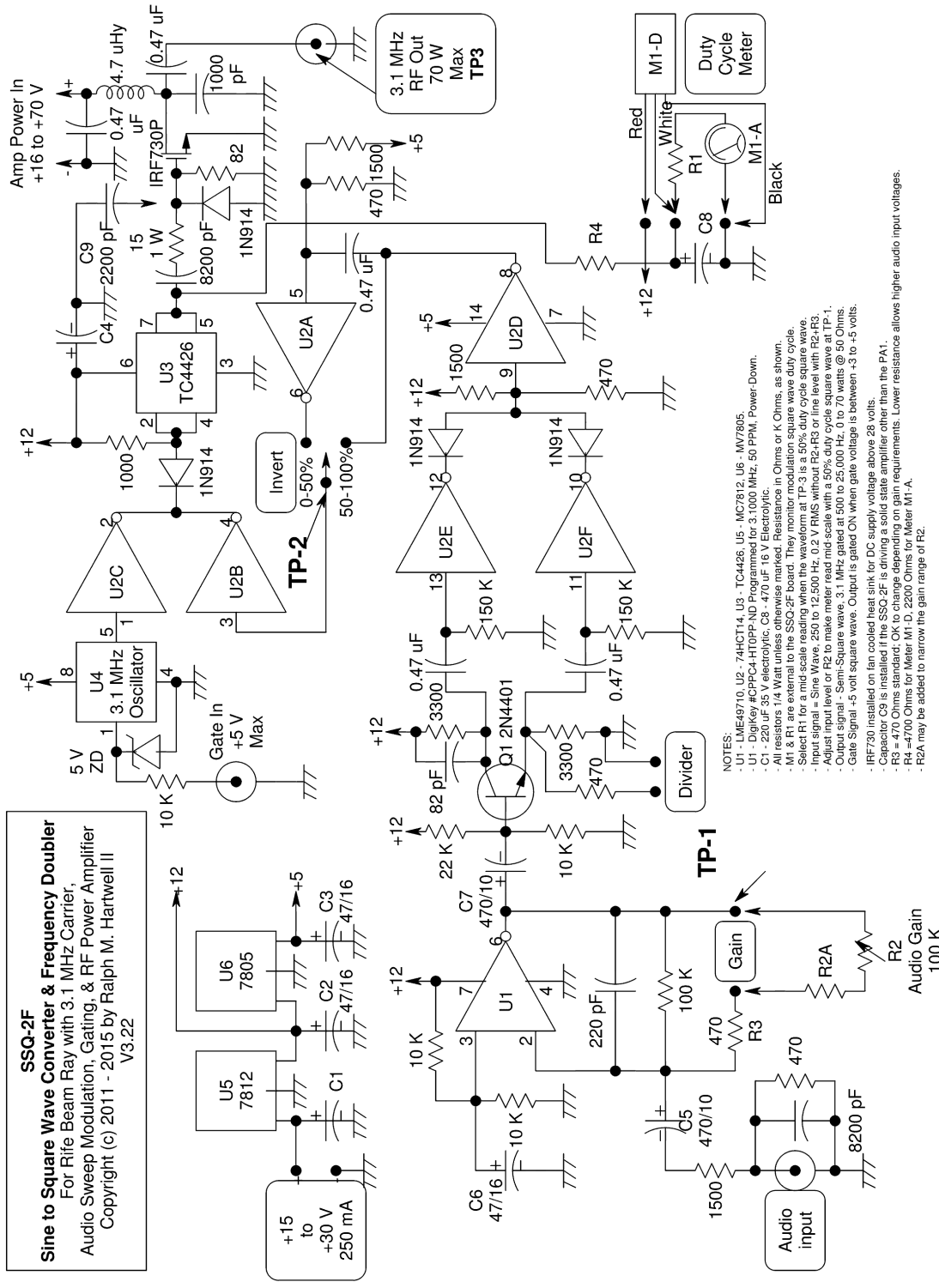

Figure 15
 Schematic Diagram of the SSQ-2F v3.22.

WAVEFORMS

The following waveform photographs were taken with a Tektronix oscilloscope set to a 20 MHz bandwidth. The amplitude of the digital signals shown in the first six pictures is +5 volts peak, ground referenced, unless otherwise noted. The test points mentioned here are found on the schematic diagram. All waveforms are taken with a 6 KHz audio input signal to the SSQ-2F.

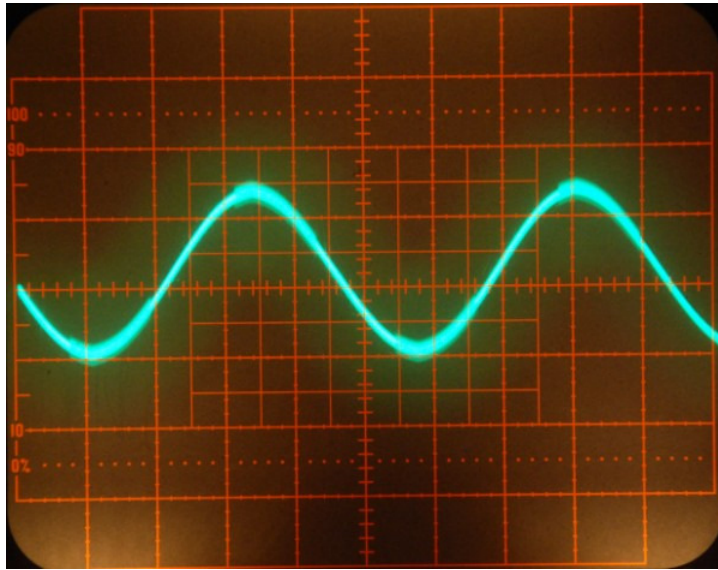

Figure 16
6 KHz audio signal at TP-1.

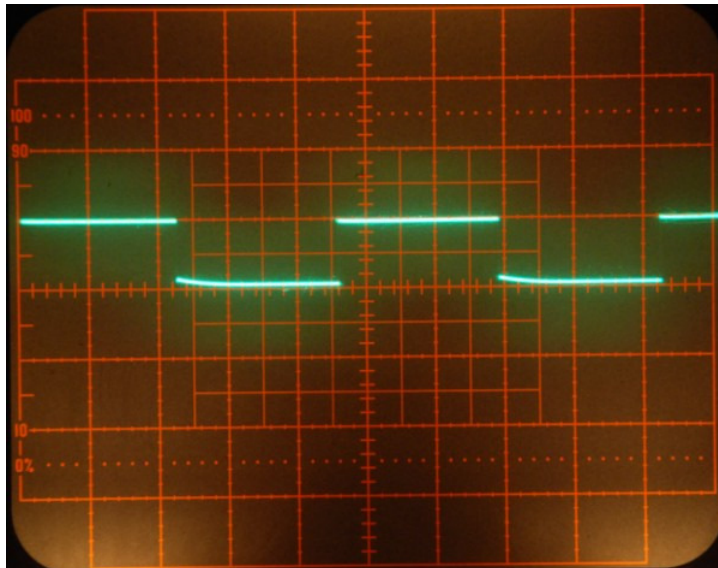

Figure 17

6 KHz 50% duty cycle square wave at TP-2. This is in the X1 mode.

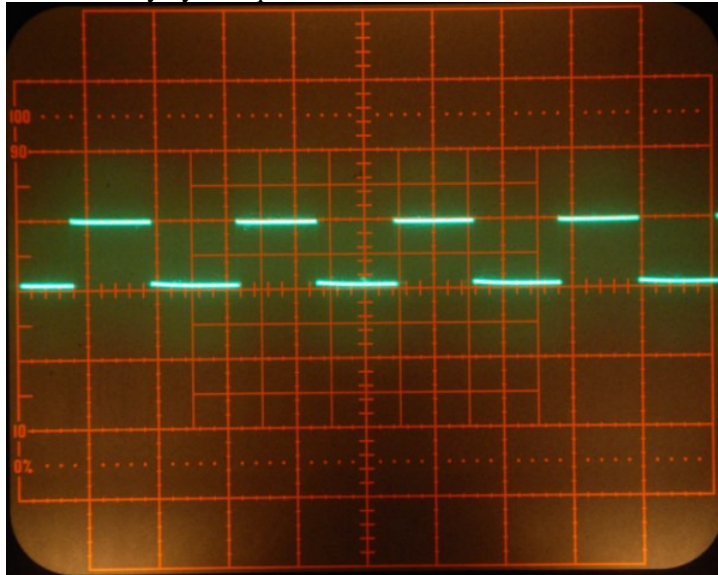

Figure 18

12 KHz 50% duty cycle square wave at TP2. This is in the X2 mode.

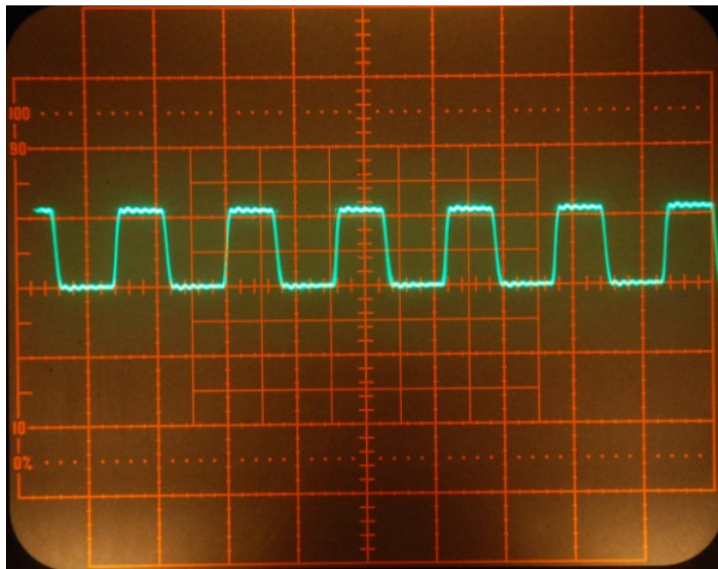

Figure 19

3.1 MHz carrier wave drive signal at U3, pins 5 & 7.

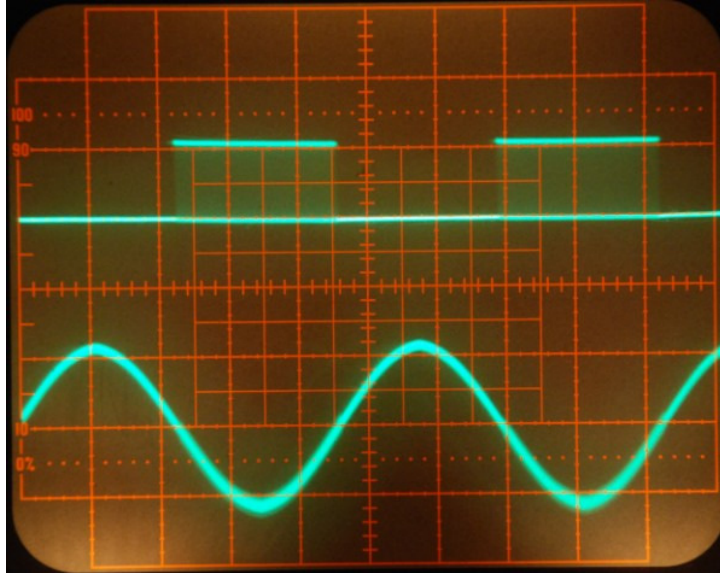

Figure 20

Bottom trace – TP-1 showing 6 KHz audio.

Top trace – TP-3 showing 3.1 MHz carrier at U3, pins 5 & 7, modulated at a 6 KHz rate by a 50% duty cycle square wave. This is in the X1, non frequency doubling mode.

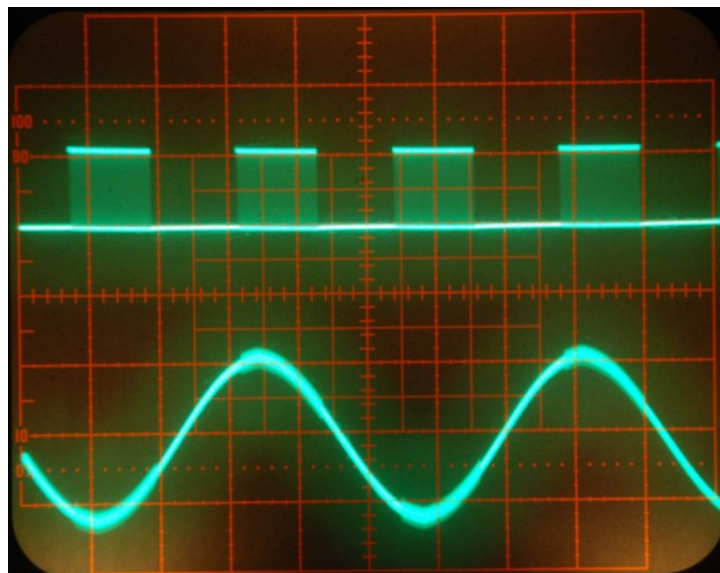

Figure 21

Bottom trace – TP-1 showing 6 KHz audio input signal.

Top trace – TP-3 showing 3.1 MHz carrier at U3, pins 5 & 7, modulated at a 12 KHz rate by a 50% duty cycle square wave. This is in the X2, frequency doubling mode.

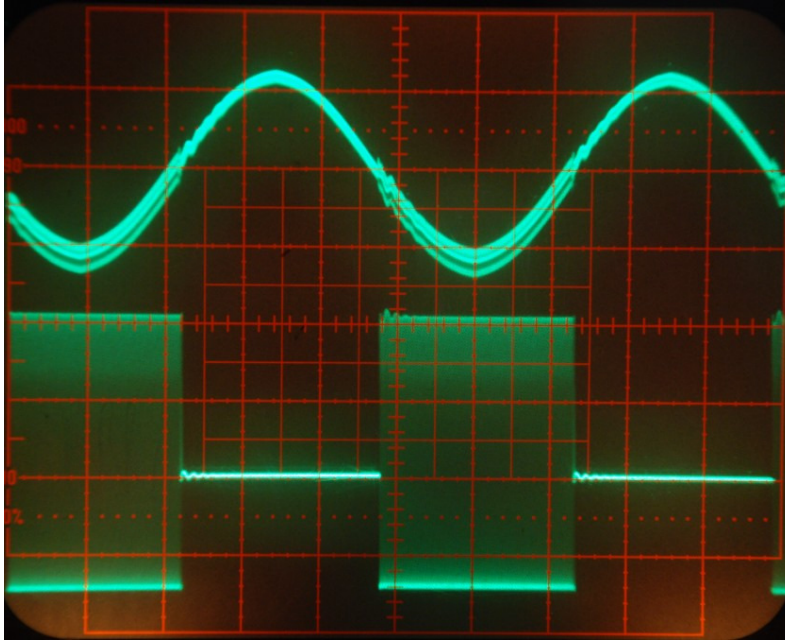

Figure 22

Top trace - TP-1 showing 6 KHz audio input signal.

Bottom trace - This is the 100 watt peak power 3.1 MHz RF carrier output waveform as seen at the RF output connector of the SSQ-2F (TP3).

The 3.1 MHz carrier is being modulated at a 50% duty cycle by a 6000 Hz audio signal. Note the very fast rise and fall times of the modulated RF pulses.

The slight ripple visible on the top leading edge of the signal burst and the ripple visible in the baseline immediately after the RF pulse is due to inductor ringing caused by the DC current flow through the output amplifier inductor.

In this picture, the SSQ-2F is being run in the X1 mode, (non-frequency doubling,) so there is only one modulated RF pulse per audio cycle.

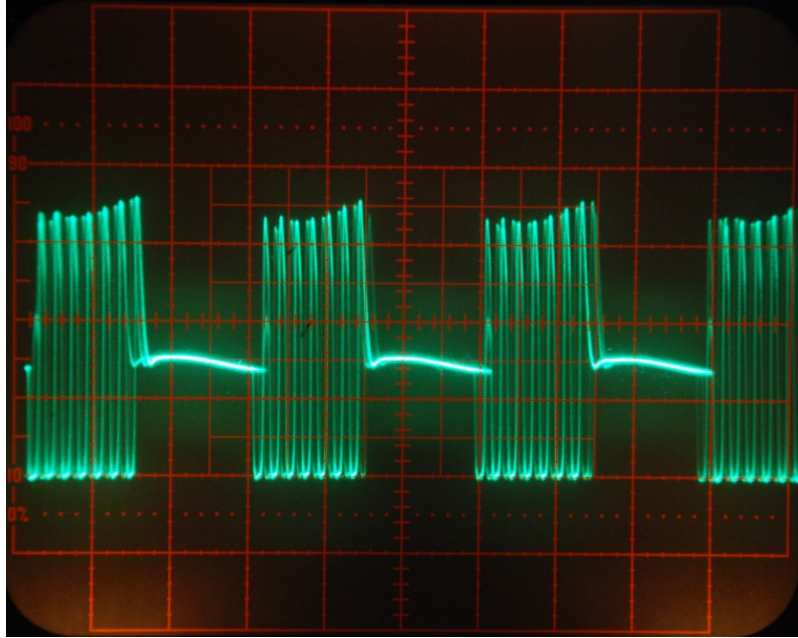

Figure 23

This is the 100 watt peak power 3.1 MHz RF carrier output waveform as seen at the RF output connector of the SSQ-2F (TP3).

The 3.1 MHz carrier is being modulated at a 50% duty cycle by a 210 KHz audio signal. There are only seven cycles of 3.1 MHz carrier in each modulation cycle. Note the very fast rise and fall times of the RF pulses.

The faint display blur is caused by the camera superimposing several oscilloscope traces on top of each other. The slight curve in the top of the signal burst and the curve in the baseline during the modulation OFF time is due to inductor ringing caused by the DC current flow through the output amplifier inductor.

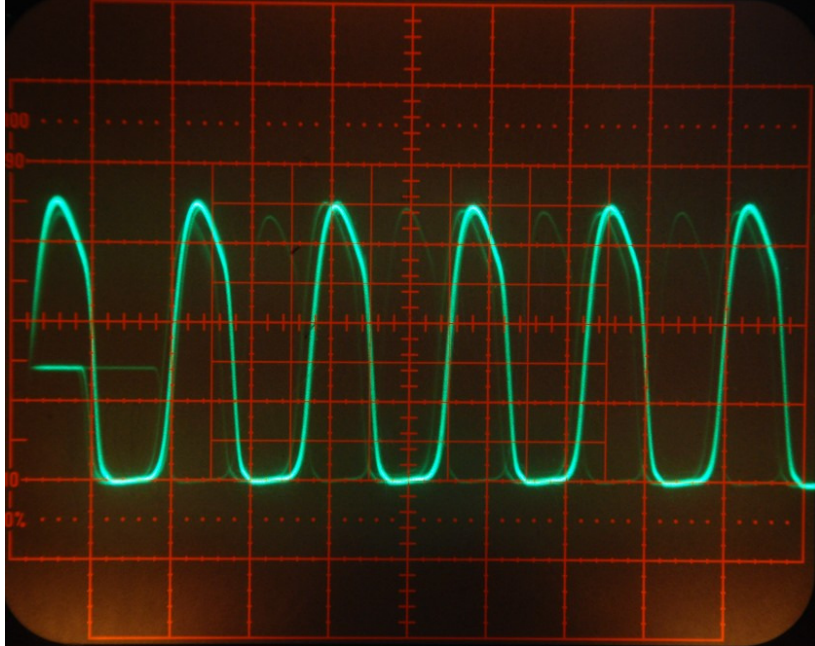

Figure 24

This is the 100 watt peak power 3.1 MHz RF carrier output waveform as seen at the RF output connector of the SSQ-2F (TP3).

The waveform is 350 volts peak to peak as measured across a 50-ohm dummy load resistance. The DC voltage to the RF amplifier section of the SSQ-2F is 70 volts. The peak RF power is 100 watts, and the average power at a 50% duty cycle is 50 watts.

This waveform is satisfactory for use in driving a vacuum tube RF amplifier, however it is not the right shape to properly drive a solid state RF amplifier. A simple modification is required to be done to the SSQ-2F to change the waveform to be more compatible with solid-state RF amplifiers.

- EOT -