

# Instruction Manual

## For the SPA5

### Signal Processor and Amplifier

V1.0

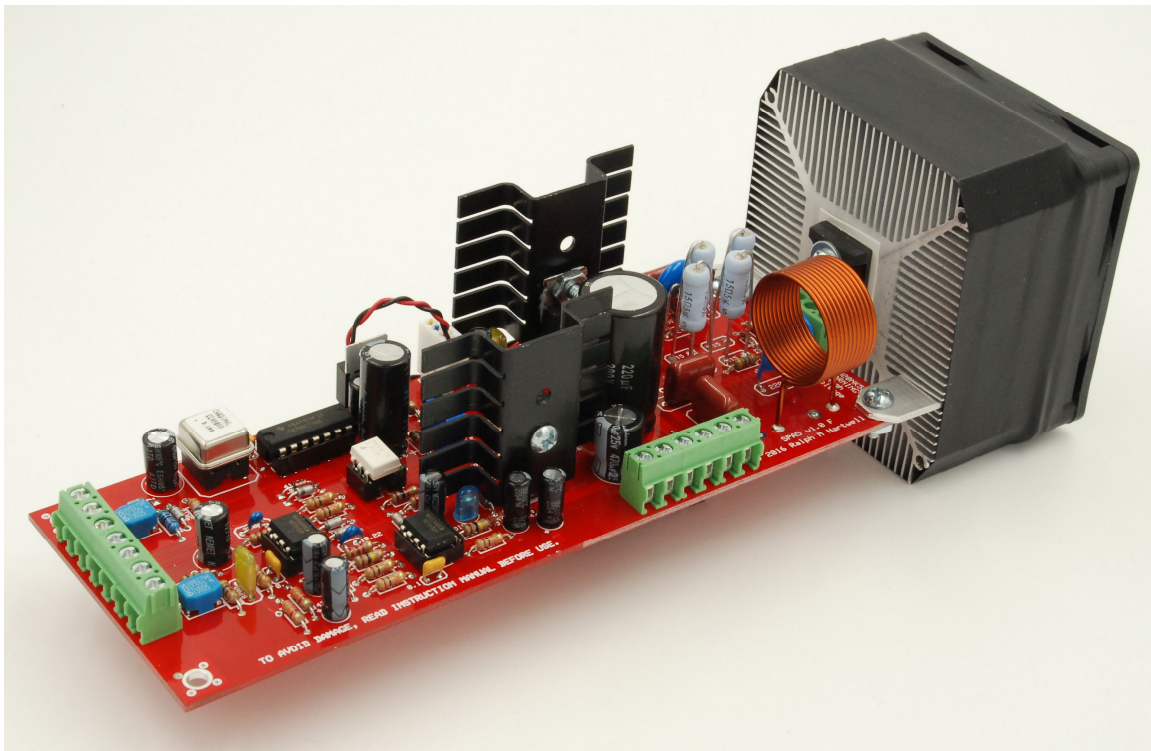

21 October 2016

© 2014 - 2016 by Ralph Hartwell  
Spectrotek Services  
All rights reserved



## **\* LEGAL AND MEDICAL DISCLAIMER \***

Spectrotek Services and Ralph M. Hartwell ARE NOT RESPONSIBLE for any damage or injuries of any sort or form that may be sustained by any person or persons, any animal, to any equipment or any other thing or things while anyone is using, modifying, testing, or experimenting with the SPA5 in any manner whatsoever. This device has not been inspected or approved by any governmental or medical agency or inspection service. No medical claims are made for, nor implied by, the sale or use of this device. Using the SPA5 is done solely at your own risk.

You are advised to always consult with your physician or other health care professional at any time should you have or think you might have a health problem of some sort. Please check with your physician or other health care professional before starting any diet, exercise, taking OTC medications or supplements and especially before taking any prescribed medication. Never stop taking any prescribed medications without first consulting your physician.

## **RADIO FREQUENCY WARNING NOTICE**

- The SPA5 contains a high-frequency switch mode power supply module designed to furnish a high voltage alternating current at a frequency of approximately 3.1 MHz across a 50 ohm resistive load impedance.
- If the SPA5 is installed incorrectly or used improperly, it is capable of causing severe radio frequency interference. To prevent this from occurring, please observe the following warnings:
- The SPA5 is to be used as a research device only, or as part of a complete system to drive a plasma tube.
- Do not touch, or allow other persons to touch, any of the internal circuitry of the SPA5 while power is applied to the SPA5.
- Dangerous RF voltage will be present when the SPA5 is operating. Contact with this RF voltage may cause painful radio frequency burns.
- The SPA5 is not intended to be used for any form of radio transmission in any manner whatsoever.
- The SPA5 is not intended to be connected to an antenna or to any radiating element or to be used for any form of radio communications in any manner whatsoever.
- The SPA5 is designed solely to be used as a source of power to operate a plasma tube.
- All electrical connections to the output terminals of the SPA5 are to be made by the use of properly shielded 50-ohm coaxial cable capable of handling at least 500 watts at 3.1 MHz.
- All connections to the SPA5 are to be made in such a manner as to minimize any RF radiation from the connecting wires.
- The operating frequency range of the SPA5 has been restricted to a 1 MHz portion of the spectrum centered at 3.1 MHz.
- Use of the SPA5 may be regulated by your local authorities. You are responsible for complying with local regulations and laws.

# Index and Table of Contents

Legal and Medical Disclaimer	3
Radio Frequency Warning Notice	4
Overview of the SPA5	7
System Connection Diagram, Figure 1	9
Terminal Block Connections, Figure 2	10
Mounting the SPA5	11
Driving a Plasma Tube with the SPA5	13
Terminal Block Connections	14
Diagnostic LED's	16
Input Signal requirements	18
SPA5 Operation – Quick Start	20
Replacing the STW20NK50Z	21
Insulating the STW20NK50Z from the Heat Sink	22
Specifications	24
Warranty Information	25
Contact Us	25
Amplifier Voltage with Bill Cheb Plasma Tubes	26
Schematic Diagram	27

## **List of Figures**

**Figure 1, Page 9** – A typical system setup using the SPA5.

**Figure 2, Page 10** – SPA5 terminal block connector identification.

**Figure 3, Page 26** – Schematic diagram of the SPA5.

## Overview of the SPA5

NOTE: In this document, all references to computer sound cards also apply to devices such as MP3 players, CD and DVD players, cell phones, and music players.

The SPA5 is a combination system which includes an audio signal processor an automatic level controller, a 3.10 MHz carrier oscillator/modulator/RF driver stage, and high-power switch-mode RF power amplifier.

The SPA5 can produce output power levels of up to 500 watts peak power or 300 watts average power when connected to a 50 Ohm load. The power output of the SPA5 is adjustable from zero to full power simply by adjusting the DC power supply voltage connected to the SPA5's RF power amplifier.

The SPA5 is fully automatic, and accurately tracks any variations in the input signal frequency or amplitude to correctly maintain a nominal 50% duty cycle modulated RF output signal. Diagnostic LED's are built into the SPA5 for verification of proper operation and as an aid in troubleshooting, should that be necessary.

The audio processor circuitry of the SPA5 has been designed to accept a sine wave frequency generated by a computer. Most computer sound systems are unable to reproduce high quality square waves above just a few hundred Hz. Most computers with standard sound cards will not produce sine wave signals correctly above 19,000 Hz. These problems can make computer sound cards virtually unusable when square wave modulated Rife systems are used. However, computers with sound reproduction systems using high sample rate hardware are capable of reproducing sine waves of much higher frequencies, in some cases, up to 90 KHz or more. These systems will also work very well with the SPA5.

The inability to generate sharp-edged square waves is a serious problem. In order to generate the higher frequency harmonic energy required for a Rife plasma tube system to work properly, the leading and trailing edges of the square wave must be "sharp," that is, the square wave must have very fast rise and fall times.

To solve this problem, the SPA5 has been designed to accept sine wave audio frequencies within the frequency range that the computer sound card can generate. The SPA5 then doubles those frequencies and converts them to clean square waves before using the square wave to modulate the 3.1 MHz carrier wave.

By doubling the input frequency, modulation frequencies of 38,000 Hz or higher (depending on the sound card) may be obtained using a standard computer sound card as the signal source. This allows the 3.1 MHz carrier to be modulated across the entire 500 to 25,000 Hz frequency range required for the 3.1 MHz Rife sweep. A frequency generator program such as Ken Uzzell's **FreX16** or **FreXmcm** is optimal for driving the SPA5. <http://frex.com.au>.

The SPA5 audio frequency doubling system allows the researcher to be able to properly implement the 3.1 or 3.3 MHz Rife Sweep protocol as outlined in the document posted at:

[http://rifevideos.com/dr\\_rife\\_and\\_philip\\_hoylands\\_3.3mhz\\_sweep.html](http://rifevideos.com/dr_rife_and_philip_hoylands_3.3mhz_sweep.html)

This sweep protocol calls for the use of a 3.1 or 3.3 MHz carrier that is 100% modulated by a square wave that slowly sweeps between 500 and 25,000 Hz. Because of the frequency doubling action of the SPA5, the computer sound card need only generate sine wave signals within the frequency range of 250 to 12,500 Hz, which is within the range of virtually any computer sound card.

The SPA5 is able to operate over the RF carrier range of 2.7 to 3.7 MHz simply by replacing the plug-in oscillator module with one of the correct frequency. Unless otherwise specified, the SPA5 is delivered with a standard 3.10 MHz oscillator installed.

The SPA5 v1.0 includes several built-in RF filters, which are designed to help prevent self-interference when operating in the RF field of the plasma tube.



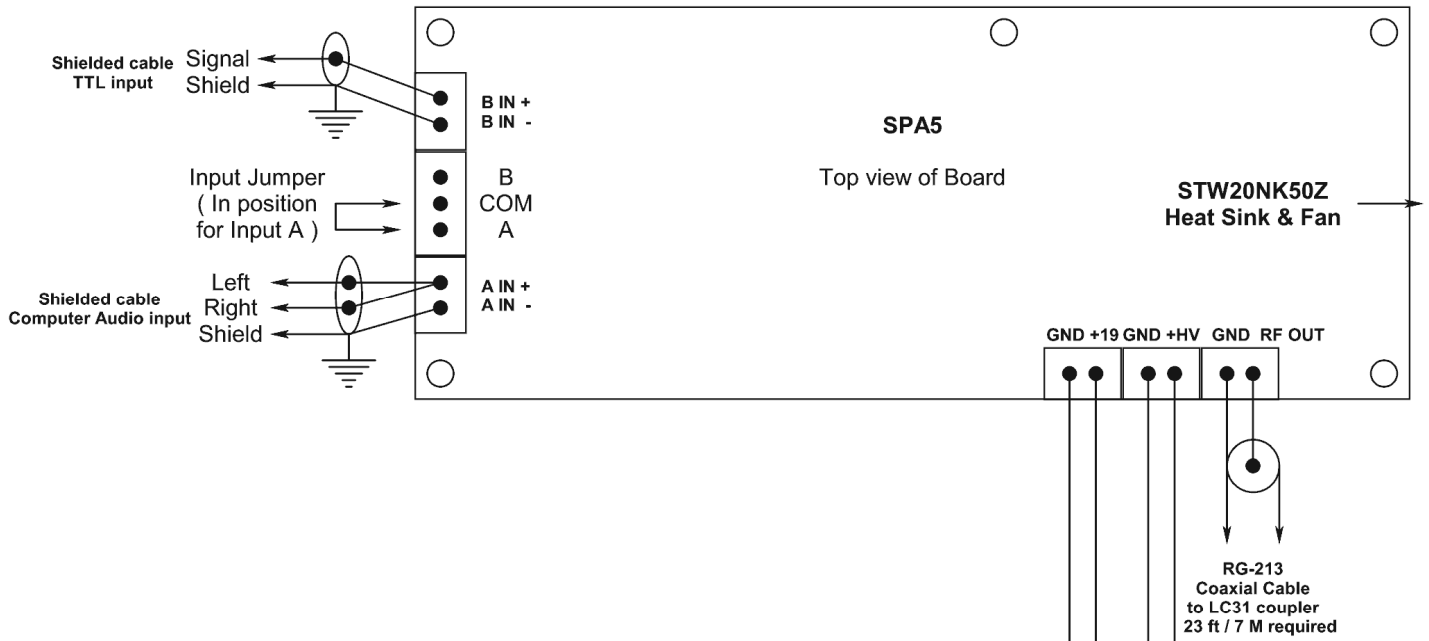

**NOTE: All GND and (-) terminals are connected together and may be grounded / earthed.**

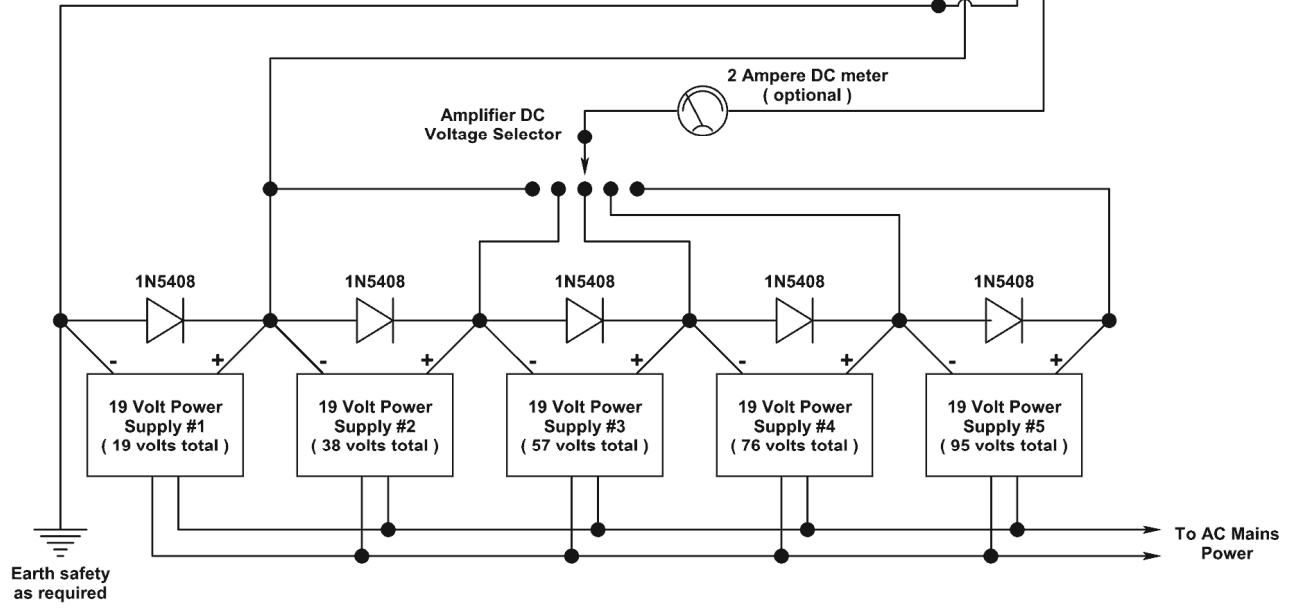

Five power supplies are shown here for a total amplifier DC voltage of 95 volts. More power supplies may be added as required for higher voltages. The maximum DC voltage allowed is 190 volts. The power supply system should be current limited to 3 amperes.

**Figure 1**

**A typical system setup using the SPA5.**



## Mounting the SPA5 in an Enclosure

The SPA5 may be mounted in a metal, plastic, or wood enclosure if desired. Although it is not normally necessary to provide shielding for the SPA5, the use of an optional metal mounting plate or enclosure is suggested.

Mounting holes are located at the outside corners of the SPA5 for mounting the board. If the SPA5 is mounted next to a metal surface, then the use of standoff supports is advisable to prevent unwanted short circuits between the underside of the SPA5 and the metal mounting surface. Metal spacers or standoffs should be used to maintain ground / earth continuity between the SPA5 and the mounting surface.

**NOTE: Electrical continuity between the large metal heat sink/fan assembly and the mounting holes of the SPA5 circuit board must be maintained or the SPA5 may become unstable during operation, possibly causing damage to the SPA5.**

It is very important to prevent outside RF energy, such as from an operating plasma tube, from entering the SPA5. Unwanted RF feedback into the SPA5 will cause erratic operation and incorrect modulation of the RF carrier.

The most common point of entry for unwanted RF energy is via the audio input cable. Using a shielded audio cable is necessary. Make sure the cable is routed well away from the high-power RF components of the system. Use the shortest length of audio cable possible. Do not route the audio cable near the plasma tube or the LC31 coupler.

In severe cases of interference, looping the audio cable 6 to 8 times through a ferrite toroid will usually eliminate the problem. Place the toroid as close to the input connections of the SSQ-2F as possible. Use a toroid core with material type 31 for best results.

## Cooling the SPA5

**If you have purchased an assembled SPA5 amplifier, it will be furnished complete with a type HS2 heat sink and cooling fan assembly.** The HS2 heat sink provides the proper cooling to allow the SPA5 to operate at full rated power. Please be sure that nothing obstructs the flow of cooling air entering the fan or the warm discharge air leaving the heat sink.

**NOTE: The cooling fan draws cool air, across the amplifier circuit board, through the heat sink, and then exhausts the warm air away from the amplifier.**

The HS2 heat sink with the SPA5 attached to it may be mounted in place in your system with the use of a clamp, a bracket, or some type of strap that will hold the heat sink assembly firmly in place. It is important that the airflow through the heat sink not be obstructed in any manner. A plentiful supply of cool air must be allowed to enter the enclosure where the amplifier is mounted. Likewise, the warm exhaust air must be allowed to freely exit the enclosure.

The fan on the SPA5 heat sink is powered by the voltage regulator of the SPA5 circuit board, so that there is no need for a separate power supply to operate the fan. If you provide your own cooling fan, the maximum current that may be drawn by the cooling fan is approximately 500 mA

(0.50 A). Excess current may overheat or damage the MC7812 voltage regulator or cause unstable operation of the SPA5 amplifier.

**CAUTION:** The cooling fan is very quiet and does not make much noise. It is easy to forget that it is running while you are working with your system. Please be careful not to allow your fingers or anything else to come in contact with the fan blades while the fan is in operation. Accidentally hitting the fan blades with your finger or a hard object such as a screwdriver may break one of the blades off of the fan hub. If this happens, it will be necessary to replace the fan.

**VERY IMPORTANT !!**

If the unit is placed in an enclosure, it is advisable to mount the air discharge side of the fan (the side of the fan facing away from the SPA5 circuit board) immediately adjacent to an opening in the enclosure to let the warm air exit the enclosure easily.

An unrestricted air intake opening must be made somewhere in the wall of the enclosure so that cool air from outside of the enclosure can enter the enclosure. The size of the air intake opening must be equal to or larger than the opening for the hot air exhaust.

## Driving a Plasma Tube from the SPA5

Because the SPA5 can provide RF power levels of up to 500 watts peak power, it is possible to drive a large plasma tube with the SPA5 without requiring an additional amplifier. However some form of coupling or matching system will be needed to match the 50 ohm output impedance of the SPA5 to the variable load presented by the plasma tube.

Plasma tubes are made in two basic types, internal electrode and external electrode tubes. Internal electrode tubes are easier to use because their electrodes are in direct contact with the gas in the plasma tube. Their drawback is that the internal electrodes absorb a lot of power during operation and they may become extremely hot, even to the point of glowing red hot. When this happens, the electrodes will begin to give off gas (outgas) and this may contaminate the gas mixture in the tube. This results in an off-color glow in the tube or outright failure of the tube to light properly. This may cause amplifier failure. Because of the heat limitation of the internal electrodes, these tubes are generally limited in the maximum amount of power they can handle without damage.

To solve the electrode overheating problem and to allow plasma tube operation at higher power levels, many experimenters are using external electrode tubes. An external electrode tube has some form of metallic electrode wrapped around the outer ends of the tube. These electrodes may be made in the form of a wrap-around collar, The “collar” electrode, such as the Spectrotek type E1(W), E2(W), E3(W), and E4(W), a spring-like wire wrapped around the tube, or a piece of metal screen wrapped around the tube.

External electrodes transfer RF power to the gas in the tube by capacitive action directly through the wall of the tube. An AC current can pass through a capacitor, but not a DC current. The external electrode forms one plate of the capacitor, and the ionized gas in the tube forms the other electrode. The glass wall of the tube serves as the insulating dielectric of the capacitor.

When a plasma tube system uses an RF carrier to drive the tube, external electrodes usually work quite well. They are limited in their power handling only by the maximum power the tube walls can withstand without melting. Heating of the tube wall occurs from two sources: the dielectric loss of the glass itself and direct heating of the tube wall by the hot, ionized gas inside the tube.

Generally, well before the point of melting the glass is reached, the gas inside the tube will heat up enough so that the tubes internal gas pressure will increase. This will cause the tube to lose its normal color and become dimmer, thereby alerting the operator to the fact that the tube is too hot.

**Commercial Antenna Tuners are not generally satisfactory for use with the SPA5. The use of the Spectrotek Services type LC31 coupler is recommended. A technical description of the coupler system may be found at [http://rife-beam-ray.com/3.1mhz\\_match/index.htm](http://rife-beam-ray.com/3.1mhz_match/index.htm)**

## SPA5 TERMINAL BLOCK CONNECTIONS:

**Please refer to Figure 2, Page 10, for the location of the connections to the SPA5 circuit board.**

All connections to the SPA5 are made by using the small screw terminals that are located in the plastic terminal blocks that are mounted along the edges of the circuit board. These will accept either solid or stranded conductor wire of up to AWG 14 in size.

When installing the wires, do not excessively tighten the screws. This will avoid damaging the screw threads in the terminal block. Remove about 1/4" or 4 mm of insulation from the end of each wire. Insert the stripped wire end into the hole in the terminal block, and then gently tighten the screw to clamp the wire in place.

Figure 2 shows the relative position of the various connectors on the SPA5. The connectors have been color coded in Figure 2 for ease of identification. Note that the terminal blocks on the SPA5 itself are all the same color.

### **( + B IN – ) Blue**

**Connections to this input must be made using a shielded cable. The shield connects to the ( - ) terminal, and the center wire or core of the cable connects to the ( + ) terminal.**

This connection accepts square wave audio signals with a frequency range of 1 to 400,000 Hz. Signals must be within the range of +3.5 to +6.0 volts, peak-to-peak. The duty cycle of the input square wave may be between 1% and 50%.

### **( + A IN – ) Green**

**Connections to this input must be made using a shielded cable. The shield connects to the ( - ) terminal, and the center wire or core of the cable connects to the ( + ) terminal.**

This connection accepts sine wave audio signals having a frequency range of 5 to 120,000 Hz. Signals must be within the range of 1.0 to 6.0 volts AC, peak-to-peak.

### **( A COM B ) Yellow**

To enable the "A" Input, place a jumper between terminals A and COM. **(Installed at factory)**  
To enable the "B" Input, place a jumper between terminals B and COM.

NOTE: It is recommended that a switch NOT be installed instead of the jumpers. Using a switch may cause RF self-interference to the SPA5 due to signal pick-up on the switch wires. If a switch is installed instead of the jumpers, then an oscilloscope must be used to verify that the RF output of the SPA5 is "clean" and has no instability or spurious oscillations present in the SPA5's RF output.

## **( GND +19 ) Violet**

**This terminal block is used to connect a fixed voltage 19 volt DC power to the logic section, RF driver stage and the heat sink cooling fan of the SPA5.**

Connect the +19 volt wire from your power supply to the +19 terminal. Connect the power supply negative wire to the GND terminal.

## **( GND +HV ) Orange**

**This terminal block is used to connect an adjustable high voltage DC power supply to the RF power amplifier of the SPA5.**

Connect the + high voltage wire from your power supply to the +HV terminal. Connect the power supply negative wire to the GND terminal. It is useful to install a 2 ampere analogue current meter in series with the positive wire. This allows monitoring of the current drawn by the amplifier during operation.

*Note that the negative ( - ) connections of the PA PWR and the logic PWR terminal blocks are common, that is, they are connected together inside the circuit board..*

## **( GND RF OUT ) Red**

**This terminal block is the RF output of the SPA5.**

Connection to this block requires the use of a shielded 50 Ohm impedance coaxial cable between the terminal block and the matching system that will be connected to the plasma tube. For full power operation at 150 watts and higher, type RG-213 cable is required. For low power systems of less than 150 watts average power, or 300 watts peak power, type RG-58 coaxial cable may be used.

Connect the center wire or core of the coaxial cable to the RF OUT terminal.

Connect the shield of the coaxial cable to the GND terminal.

**Note that only solid dielectric, 50 Ohm coaxial cable with a length of 23 feet / 7 meters plus or minus one foot / 31 cm in length may be used. The cable type and length is critical for proper amplifier tuning and operation. Use of an incorrect cable type or cable length may cause amplifier failure.**

## Diagnostic LED's

The SPA5 has 5 LED's on the circuit board for verification of proper operation. The LED's are a troubleshooting aid in case of a malfunction of the amplifier.

The function of the LED's is as described below.

**AUDIO OK (Blue)** – This LED is used only with INPUT A.

This LED illuminates when the input audio level is sufficient for proper operation of the SPA5.

When this LED is on, it indicates that the automatic level control of the SPA5 is receiving a strong enough input audio signal at INPUT A for stable operation. This ensures that the modulation duty cycle will be maintained close to the 50% duty cycle set point of the tracking circuit. Note that this LED may blink or flash momentarily during operation when multiple input frequencies are being sent to the SPA5, this is normal.

**GATE OPEN (Green)** – This LED is used only with INPUT A.

When this LED is off, the audio signal is not being sent to the modulator, and the SPA5 will not output any RF power to the plasma tube.

When this LED is on, this indicates that the input audio signal at INPUT A is strong enough to override any internal circuit noise. The audio will be doubled in frequency and then sent to the modulator, causing the SPA5 to produce RF power to the plasma tube.

**IPA DRIVE (Red)** – This LED is used with INPUT A and INPUT B.

When this LED is on, this indicates that RF drive is being sent to the IFR740PBF driver stage. Note that this LED may blink or flash momentarily during operation when multiple input frequencies are being sent to the SPA5, this is normal.

**PA 1 DRIVE (Red)** – This LED is used with INPUT A and INPUT B.

When this LED is on, this indicates that amplifier RF drive is being produced by the IFR740PBF driver amplifier. Note that this LED may blink or flash momentarily during operation when multiple input frequencies are being sent to the SPA5, this is normal.



**PA 2 DRIVE (Yellow)** – This LED is used with INPUT A and INPUT B.

When this LED is on, this indicates that amplifier RF drive from the IRF740PBF driver amplifier is being sent to the STW20NK50Z output power amplifier. Note that this LED may blink or flash momentarily during operation when multiple input frequencies are being sent to the SPA5, this is normal.

## **Input Signal requirements for the SPA5**

**CAUTION: When the modulation frequency approaches or exceeds 250,000 Hz, excessive RF voltages will be developed in the SPA5's tank circuit and the LC31 coupler. These higher than normal voltages may cause the STW20NK50Z MOSFET in the SPA5 to fail.**

### **When Using INPUT A:**

**With sine wave audio frequencies from a computer or other sine wave frequency generator.**

The frequencies must be within the range of 5 to 120,000 Hz.

The SPA5 will modulate the RF carrier with the input frequency multiplied by 2.

Do not exceed the maximum allowable voltage of 10 volts peak-to-peak at INPUT A of the SPA5 to prevent damage to the audio processor input channel.

A peak-to-peak audio input voltage between 1.4 to 3.0 volts is recommended for best performance.

**NOTE: Terminals "A" and "COM" must be connected together when using INPUT A.**

### **When Using INPUT B:**

**With a frequency generator that can output TTL square wave frequencies between 1 to 240,000 Hz.**

The duty cycle of the modulated RF output of the SPA5 will follow the duty cycle of the input frequency set by the external frequency generator.

The SPA5 will modulate the RF carrier with the input frequency.

Do not exceed the maximum allowable voltage of 6.0 volts peak-to-peak at INPUT A of the SPA5 to prevent damage to the INPUT B channel.

The frequency generator must be capable of producing a 5 volt peak-to-peak, square wave output signal.

**NOTE:** A minimum of 2.25 Volts Peak to Peak (VPP) is required to trigger the SPA5. The peak voltage should not exceed 6.0 volts to avoid damage to the input circuits in the SPA5. To avoid possible damage to the SPA5, the output voltage from the frequency generator should be zero when the generator is not producing a signal. Some signal generators default to an idle voltage of +5 volts when no signal is being produced. This steady DC voltage may cause damage to the input circuit of the SPA5.

Ideally, the drive signal should be a 50% duty cycle square wave TTL signal, with a voltage swing from 0 to +5 Volts.

**NOTE: Terminals “B” and “COM” must be connected together when using INPUT B.**

# SPA5 Operation – Quick Start

**Check to be sure that the following wiring is connected properly:**

- 19 volt logic power supply wires to SPA5.
- HV power supply wires to SPA5.
- Coaxial cable from the SPA5 RF output terminals to the LC31 coupler RF input terminals.
- Wires from the LC31 coupler output terminals to the plasma tube electrodes.
- Audio signal wires from the computer or other signal generator, or;
- Square wave signal wires from an external frequency or function generator.
- Is the cooling fan (if installed) for the LC31 coupler running?

**After ensuring that all the wiring is complete, begin system power-up.**

- Check that the audio or square wave input to the SPA5 is OFF.
- Check that the HV power is OFF.
- Turn the 19 volt logic power to the SPA5 ON.
- Wait 10 seconds for the circuits in the SPA5 to stabilize.
- Adjust the HV power to about 75 volts.
- Turn the audio or square wave input to the SPA5 ON.
  - The level of the computer audio should be between 1.5 to 3.0 volts.
  - The level of the square wave signal should be 5 volts peak to peak.
- After about two seconds. The diagnostic LED's on the SPA5 will illuminate, and the plasma tube should light.
- If the plasma tube appears normal, you may increase the HV power to the normal operating voltage for your plasma tube.

**NOTE** – If the signal from the computer is too low, the BLUE AUDIO OK LED will be very dim or even off. Some fluttering or blinking of the blue LED is normal when using multi-frequency input signals, however, when a single frequency is being used, all of the LED's should be illuminated steadily.

**System power-down.**

- Turn the HV power OFF.
- Turn the 19 volt logic power OFF.

## Replacing the STW20NK50Z on the SPA5

Although the STW20NK50Z MOSFET that is used in the SPA5 is a very rugged device, it is still possible for it to fail if the SPA5 is operated under an excessive load or under improper operating conditions. Should this happen, it will be necessary to replace the STW20NK50Z MOSFET. This is not particularly difficult to do. Please read the following sequence of operations before attempting to replace the transistor.

1 – Using a small flat-blade screwdriver, carefully loosen the three clamping screws in the terminal strip that fastens the leads of the STW20NK50Z MOSFET in place.

2 – Remove the two 6-32 x 3/8” Phillips head screws and nuts that hold the SPA5 to aluminum mounting bars that are attached to the heat sink. Place the screws and nuts where they will not become lost.

3 – Carefully remove the SPA5 from the heat sink assembly.

4 – Using a Phillips head or a flat-blade screwdriver, unscrew the 6-32 x 3/4” screw and flat washer that clamps the STW20NK50Z MOSFET against the heat sink. Place the screw and flat washer where they will not become lost.

5 – Carefully remove the defective STW20NK50Z MOSFET from the heat sink.

Because the MOSFET will be probably stick to the Bergquist thermal pad that is between the MOSFET and the heat sink, you may have to use a pair of pliers to carefully pull the defective MOSFET away from the thermal pad. Gently, but firmly, grasp the sides of the defective MOSFET with the pliers and “rock” the MOSFET from side to side until it breaks free of the thermal pad. Be sure not to damage the thermal pad. It is very soft, and scratches or punctures easily. If it is damaged in any way, it will be necessary to replace it with a new thermal pad of the same type before installing the new MOSFET against the heat sink.

6 – Take the new STW20NK50Z MOSFET and carefully bend its leads into the same shape as the leads of the defective MOSFET.

Do not bend them too sharply or they may weaken and break off at the bend.

7 – Carefully trim approximately 1.5 mm from the end of the pins of the MOSFET. Be careful not to remove too much of the pin length.

8 – Using a small piece of lint free cloth and 100% isopropyl alcohol, gently clean the surface of the Bergquist thermal pad and the metal surface of the STW20NK50Z MOSFET that will mount against the thermal pad.

9 – Carefully position the replacement MOSFET against the surface of the thermal pad, and press it firmly against the thermal pad.

10 – Using the 6-32 screw and the flat washer, clamp the new MOSFET firmly against the Bergquist thermal pad and heat sink. Do not allow the MOSFET and the thermal pad to twist sideways while tightening the screw.

Although it may seem that the length of the 6-32 screw is longer than it needs to be, it is necessary to use a long screw in order to spread the clamping force across a number of screw threads in the heat sink. The screw must be tightened very firmly against the transistor. The flat washer must be used to spread the clamping force over the transistor body and prevent cracking of the transistor case.

11 – Carefully position the SPA5 circuit board so that the leads of the new STW20NK50Z enter the holes of the mounting block on the SPA5. Be sure that you do not bend the leads of the STW20NK50Z in the process.

12 - When you observe that the leads have entered the mounting block correctly, then you may replace the two Phillips head screws and nuts that clamp the SPA5 circuit board to the aluminum mounting bars that are attached to the heat sink.

13 – Gently, but firmly, tighten the three clamp screws that hold the leads of the STW20NK50Z to the SPA5 circuit board. **Do not omit this step or the MOSFET may be destroyed during operation or the amplifier may refuse to function.**

14 – Inspect your work to make sure that there are no short circuits, metal particles, or anything else that might interfere with the proper operation of the SPA5. If all is correct, you may replace the heat sink assembly and the SPA5 in your system and resume normal operation.

## **Electrically Insulating the STW20NK50Z from the heat sink**

**This section only applies when it is necessary to replace the output transistor on the SPA5, or if you are using your own heat sink.**

Because the STW20NK50Z generates a considerable amount of heat in a small package, a high quality thermal pad is required for safe operation of the STW20NK50Z.

The STW20NK50Z is operating at both a high DC voltage and a high RF voltage; therefore it is necessary to insert some form of electrical insulator (thermal pad) between the STW20NK50Z and the heat sink base plate. This insulator must be made of some material which both insulates the high voltage and at the same time it must be a good conductor for heat to allow the heat to flow from the STW20NK50Z to the heat sink base plate. Unfortunately, most materials which are good insulators for electricity are also good insulators for heat. Manufacturers have gone to a great deal of trouble and expense to produce devices, commonly referred to as "thermal pads" which will function properly.

The Bergquist SSPA5000-0.015-00-104 thermal pad is recommended for use with the SPA5. If this pad is not available, a Wakefield 174-9-250P thermal pad may be substituted. However, the heat transfer capability of the Wakefield pad is approximately 50% of the Bergquist pad. Therefore when using the Wakefield thermal pad, the SPA5 should not be operated above 300 Watts output with modulation duty cycles above 70%.

Before attaching the STW20NK50Z and the Bergquist thermal pad to the heat sink, use a liquid cleaning solution, such as 100% isopropyl alcohol and a lint free rag to carefully clean the underside of the STW20NK50Z and the area of the heat sink where the STW20NK50Z is to be

mounted. Make sure that both sides of the thermal pad are very clean. Be sure that there are no stray particles of metal, lint, fiber, or other materials on the surface of the transistor, the thermal pad, or the heat sink before mounting the STW20NK50Z to the heat sink.

**When installing the thermal pad do NOT use any paste type thermal compound.** Using paste type thermal compound will cause decreased heat transfer and may cause damage to the thermal pad and/or destruction of the STW20NK50Z.

# **SPECIFICATIONS:**

## **DC Power Supply Input:**

- **SPA5 Logic circuits:** +19 to +22 volts DC filtered and regulated, at 1.75 Ampere maximum. The actual current required varies with the modulation duty cycle.
- 
- **SPA5 RF output amplifier:** +12 to +190 volts DC maximum, filtered and regulated at 2.5 amperes maximum. The actual current required varies with the RF power output and the modulation duty cycle.

## **Input “A” - Audio Signal Limits:**

- Sine wave audio signal from a computer, or other frequency source.
- Signal level must be within the limits of 1.0 to 6.0 volts peak-to-peak.
- 5 to 75,000 Hz when using a +HV voltage of 170 volt or less.
- 5 to 120,000 Hz when using a +HV voltage of 190 volt or less.

## **Input “A” – Duty Cycle Control:**

- For an input signal level between 1.0 and 6.0 volts, the modulation duty cycle of the RF output will remain within the limits of 48 to 50%.
- The modulation duty cycle of the modulated RF output is constant when the frequency of the input signal is between 5 to 120,000 Hz.

## **Input “B” - Audio Signal Limits:**

- Square wave with a 50% duty cycle.
- The input signal level must be within the limits of 0 to 6.0 volts peak-to-peak.
- 1 to 400,000 Hz when using a +HV voltage of 170 volt or less.
- 1 to 150,000 Hz when using a +HV voltage of 190 volt or less.

## **Carrier Frequency:**

- 3.1MHz (standard) or 3.3 MHz (alternate) or custom. The carrier frequency must be specified at time of order. The carrier frequency may be changed by the user. This is done by replacing the plug-in standard frequency oscillator module with a custom module of a different frequency.
- Customer requested frequencies in the range of 2.7 MHz to 3.7 MHz are available on special order.

## **RF Power Output:**

- The SPA5 will produce up to 500 watts peak power, or 250 watts average power as measured across a 50-ohm load when the carrier is modulated by a 50% duty cycle square wave.



## **Warranty**

All our products carry a one (1) year warranty against manufacturing defects. Mechanical damage is not covered; for instance, if you dropped it on the floor and then accidentally stepped on it. For warranty service, you pay shipping to us; we pay shipping back to you.

Kits assembled by the purchaser are also have a one (1) year against component failure. Breakage or overheating damage from soldering of components during assembly is not covered under warranty.

Damage to the IRF740PBF or the STW20NK50Z transistors due to over voltage operation or inadequate cooling is not covered under warranty.

For all warranty claims or equipment service, please contact us by email or telephone before returning equipment for service.

Out-of-Warranty repair service is at the rate of \$20/hour, with a maximum charge of \$50 per item, unless otherwise specified. Please contact us for additional pricing on custom repair services.

## **Contact us**

Ralph Hartwell

Spectrotek Services

641 Sisson Road  
Natchitoches, LA  
71457-6743  
USA

318-527-6766

ralph@spectrotek.com

<http://rife-beam-ray.com>

<http://rifebeamray.com>

<http://w5jgv.com/rife>

## **DC power supply voltage for the SPA5 when used with various Bill Cheb Plasma Tubes** ( Listed in order of tube power handling capacity. )

**Cheb SSQ-PT** - The maximum DC supply voltage to the SPA5 should be limited to 76 volts or less to avoid damage to the Phanotron tube. This will result in an approximate power of about 30 watts average power or 70 watts peak power. **The recommended operating voltage for this tube is 57 volts or less.**

**Cheb 5-inch Phanotron tube** - The maximum DC supply voltage to the SPA5 should be limited to 100 volts or less to avoid damage to the Phanotron tube. This will result in an approximate power of about 75 watts average power or 150 watts peak power. **The recommended operating voltage for this tube is 114 volts or less.**

**Cheb 8-inch Phanotron tube** - The maximum DC supply voltage to the SPA5 should be limited to 115 volts or less to avoid damage to the Phanotron tube. This will result in an approximate power of about 125 watts average power or 250 watts peak power. **The recommended operating voltage for this tube is 115 volts or less.**

**Cheb SSQ-ST** The maximum DC supply voltage to the SPA5 should be limited to 133 volts or less to avoid damage to the SSQ-ST or the SPA5. This will result in an approximate power of about 175 watts average power or 350 watts peak power. Using DC voltages in excess of this value may cause the STW20NK50Z MOSFET in the SPA5 to fail. **The recommended operating voltage for this tube is 133 volts or less.**

**Cheb SSQ-BAT** - The maximum DC supply voltage to the SPA5 should be limited to 190 volts or less to avoid damage to the SPA5 amplifier. This will result in an approximate power output to the tube of about 250 watts average power / 500 watts peak power. Using DC voltages in excess of this value may cause the STW20NK50Z MOSFET to fail. **The recommended operating voltage for this tube is 152 volts or less.**

**Cheb SSQ-BAT** - The maximum DC supply voltage to the SPA5 should be limited to 170 volts or less to avoid damage to the SPA5 amplifier. This will result in an approximate power output to the tube of about 250 watts average power / 500 watts peak power. Using DC voltages in excess of this value may cause the STW20NK50Z MOSFET to fail. **The recommended operating voltage for this tube is 133 volts or less.**

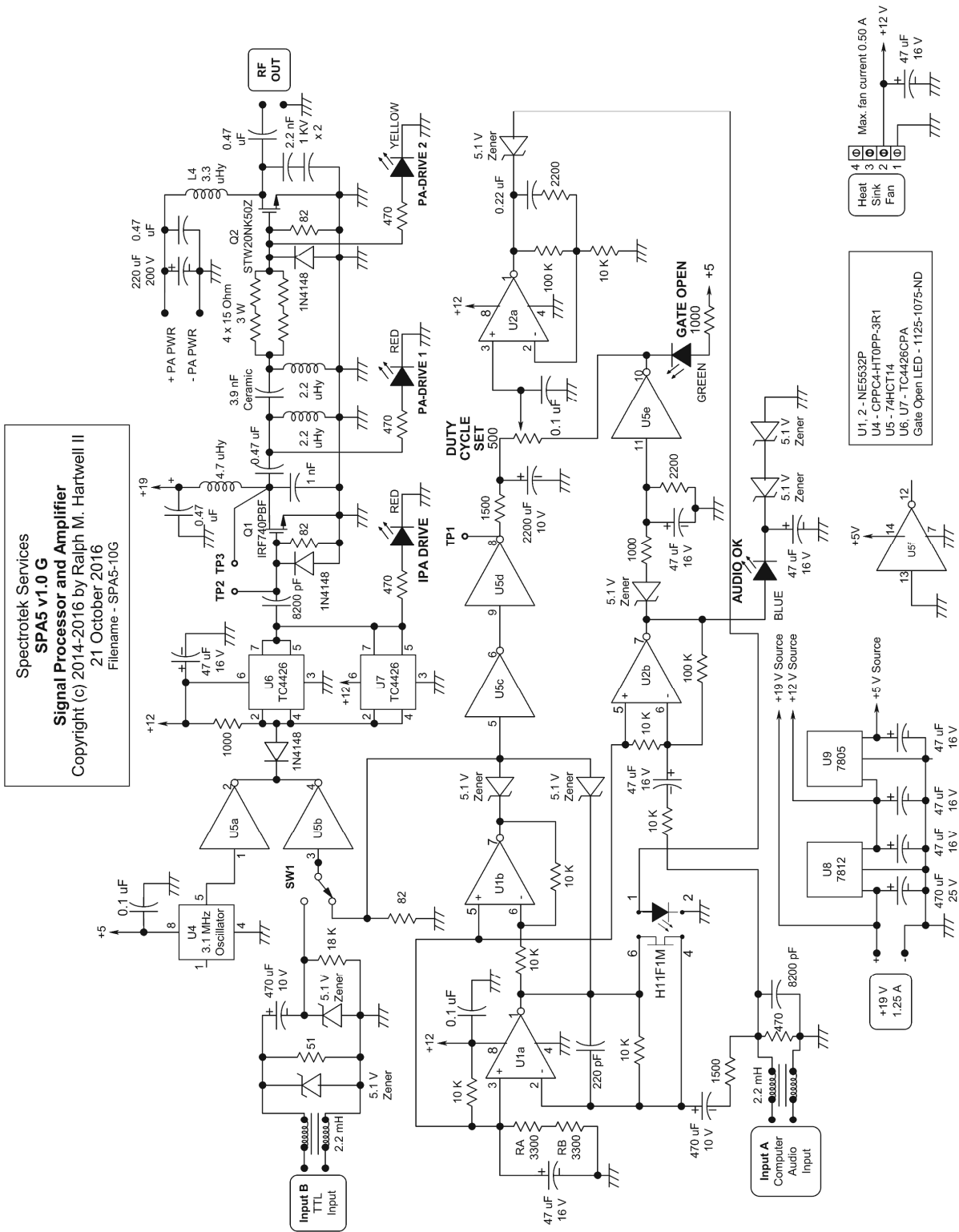



Edited by CAT