

Instruction Manual

SPA4 Controller Board

V2.0

For Rife Plasma Tube Systems

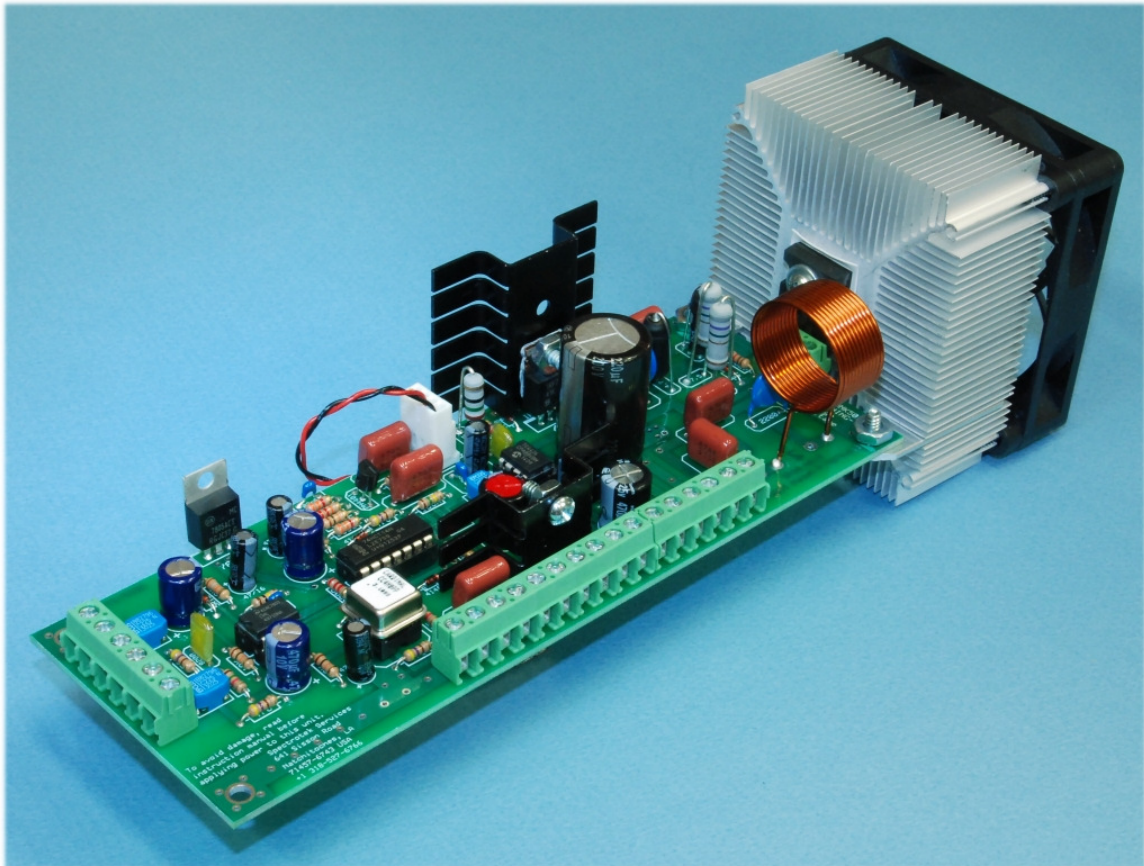

4 August 2015

© 2015 by Ralph Hartwell
Spectrotek Services
All rights reserved

*** LEGAL AND MEDICAL DISCLAIMER ***

Spectrotek Services and Ralph M. Hartwell ARE NOT RESPONSIBLE for any damage or injuries of any sort or form that may be sustained by any person or persons, any animal, to any equipment or any other thing or things while anyone is using, modifying, testing, or experimenting with the SPA4 in any manner whatsoever. This device has not been inspected or approved by any governmental or medical agency or inspection service. No medical claims are made for, nor implied by, the sale or use of this device. Using the SPA4 is done solely at your own risk.

You are advised to always consult with your physician or other health care professional at any time should you have or think you might have a health problem of some sort. Please check with your physician or other health care professional before starting any diet, exercise, taking OTC medications or supplements and especially before taking any prescribed medication. Never stop taking any prescribed medications without first consulting your physician.

RADIO FREQUENCY WARNING NOTICE

- The SPA4 contains a high-frequency switch mode power supply module designed to furnish a high voltage alternating current at a frequency of approximately 3.1 MHz across a 50 ohm resistive load impedance.
- If the SPA4 is installed incorrectly or used improperly, it is capable of causing severe radio frequency interference. To prevent this from occurring, please observe the following warnings:
- The SPA4 is to be used as a research device only, or as part of a complete system to drive a plasma tube.
- Do not touch, or allow other persons to touch, any of the internal circuitry of the SPA4 while power is applied to the SPA4.
- Dangerous RF voltage will be present when the SPA4 is operating. Contact with this RF voltage may cause painful radio frequency burns.
- The SPA4 is not intended to be used for any form of radio transmission in any manner whatsoever.
- The SPA4 is not intended to be connected to an antenna or to any radiating element or to be used for any form of radio communications in any manner whatsoever.
- The SPA4 is designed solely to be used as a source of power to operate a plasma tube.
- All electrical connections to the output terminals of the SPA4 are to be made by the use of properly shielded 50-ohm coaxial cable capable of handling at least 500 watts at 3.1 MHz.
- All connections to the SPA4 are to be made in such a manner as to minimize any RF radiation from the connecting wires.
- The operating frequency range of the SPA4 has been restricted to a 1 MHz portion of the spectrum centered at 3.1 MHz.
- Use of the SPA4 may be regulated by your local authorities. You are responsible for complying with local regulations and laws.

Index and Table of Contents

Legal and Medical Disclaimer	3
Radio Frequency Warning Notice	4
Overview of the SPA4	7
System Connection Diagram	8
Terminal Block Connections	9 - 12
Mounting the SPA4	13
Metering the Square Wave Duty Cycle	14
Making Your Own Duty Cycle Meter	15
Duty Cycle Meter Calibration Procedure	15
Setup and General Operation of the SPA4	16 – 21
Amplifier Voltage with Bill Cheb Plasma Tubes	22
Driving a Plasma Tube with the SPA4	23
RF Coupling Systems	23
Mounting the SPA4 and the HS2 Heat Sink	24
Cooling Fan	24
Replacing the STW20NK50Z	25
Insulating the STW20NK50Z from the Heat Sink	27
Specifications	28
Warranty Information	30
Contact Us	30
Schematic Diagram	31
Waveforms	32 - 40

List of Figures

Figure 1, Page 8 – A typical system setup using the SPA4.

Figure 2, Page 9 – SPA4 terminal block connector identification.

Figure 3, Page 31 – Schematic diagram of the SPA4.

Figure 4 – 12, Pages 32 – 36 – RF output waveforms of the SPA4 connected to a 50 ohm dummy load.

Figure 11 – 18, Pages 37 – 40 – RF output waveforms of the SPA4 connected to a Cheb 8” Phantotron plasma tube.

Overview of the SPA4

The SPA4 is a combination wide frequency range signal processor and high-power RF amplifier. The SPA4 is designed to drive a plasma tube for use with Rife plasma tube systems. The SPA4 can produce power levels of up to 500 watts peak power across a 50 Ohm load, and average power levels of up to 300 watts. The power output is adjustable from zero to full power simply by adjusting the DC power supply voltage that is supplied to the SPA4 output amplifier.

The SPA4 will accept frequency signals from many different frequency generators, such as a computer, a GB-4000, any of the F-series generators, the PROGEN II 4059, a UDB1108S, the Spooky2 frequency generator, and many more.

The SPA4 is able to operate over the RF carrier range of 2.6 to 3.6 MHz simply by replacing the plug-in oscillator module with one of the correct frequency. Unless otherwise specified, the SPA4 is delivered with a standard 3.10 MHz oscillator installed.

The SPA4 v2.0 incorporates several new filters, which are designed to help prevent RF self-interference when operating in the RF field of the plasma tube.

Because of the SPA4's special functions and abilities, it is important to read and understand the contents of this operations manual to prevent damage to the unit and possible injury to the operator.

What types of signals and frequencies does the SPA4 accept?

The SPA4 will accept sine, triangle, or square wave signals from various frequency generators and convert them to fast rise time square waves before using them to modulate the 3.1 MHz RF carrier wave.

The "INPUT A" of the SPA4 will accept computer-type audio signal. In this mode, the SPA4 has been designed for optimum operation within the frequency range of 10 to 30,000 Hz, thus making it practical to use computer sound cards, MP3 players, as well as CD and DVD players to generate the audio modulation signal. Any standard frequency or function generator may be used as an audio signal source for the SPA4.

The "INPUT B" of the SPA4 will accept modulation signals within the frequency range of 1 to 400,000 Hz.

How can I power the SPA4?

The SPA4 may be powered from a power supply built from a number of laptop computer power adapters or any other suitable power supply.

Is the SPA4 a complete Rife system?

No. Besides the SPA4, you will require a frequency generator, a suitable power supply, a plasma tube, and a coupler to transfer the output power of the SPA4 to your plasma tube. We recommend the Spectrotek LC31 coupler.

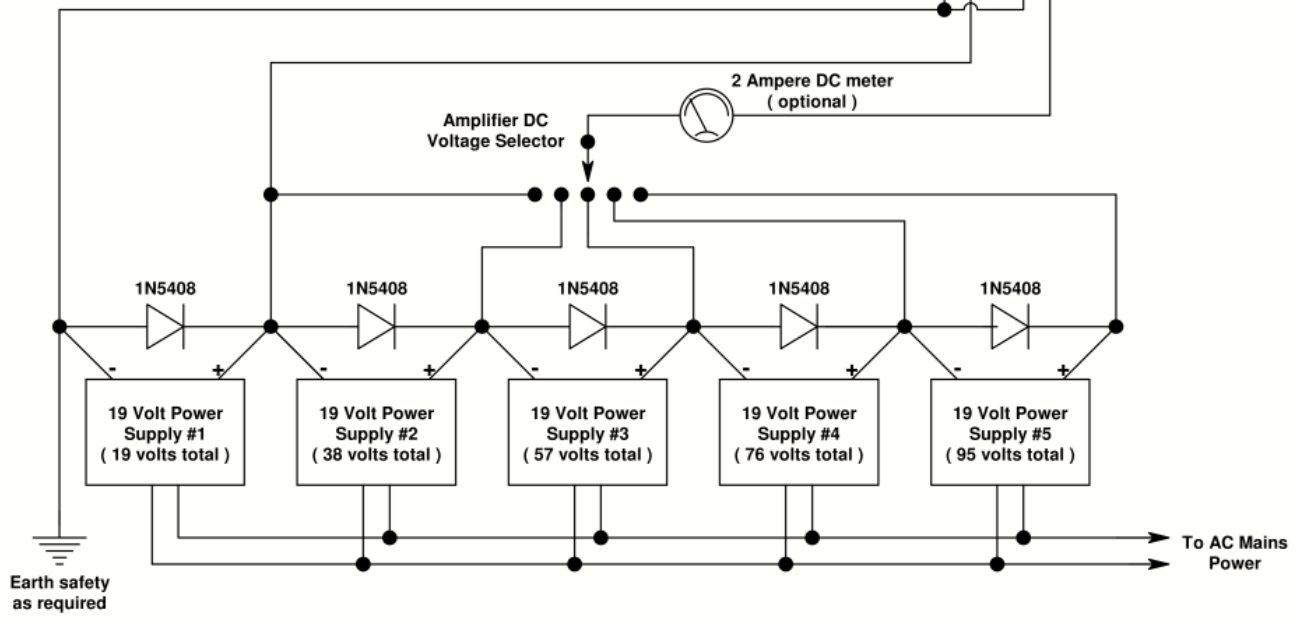
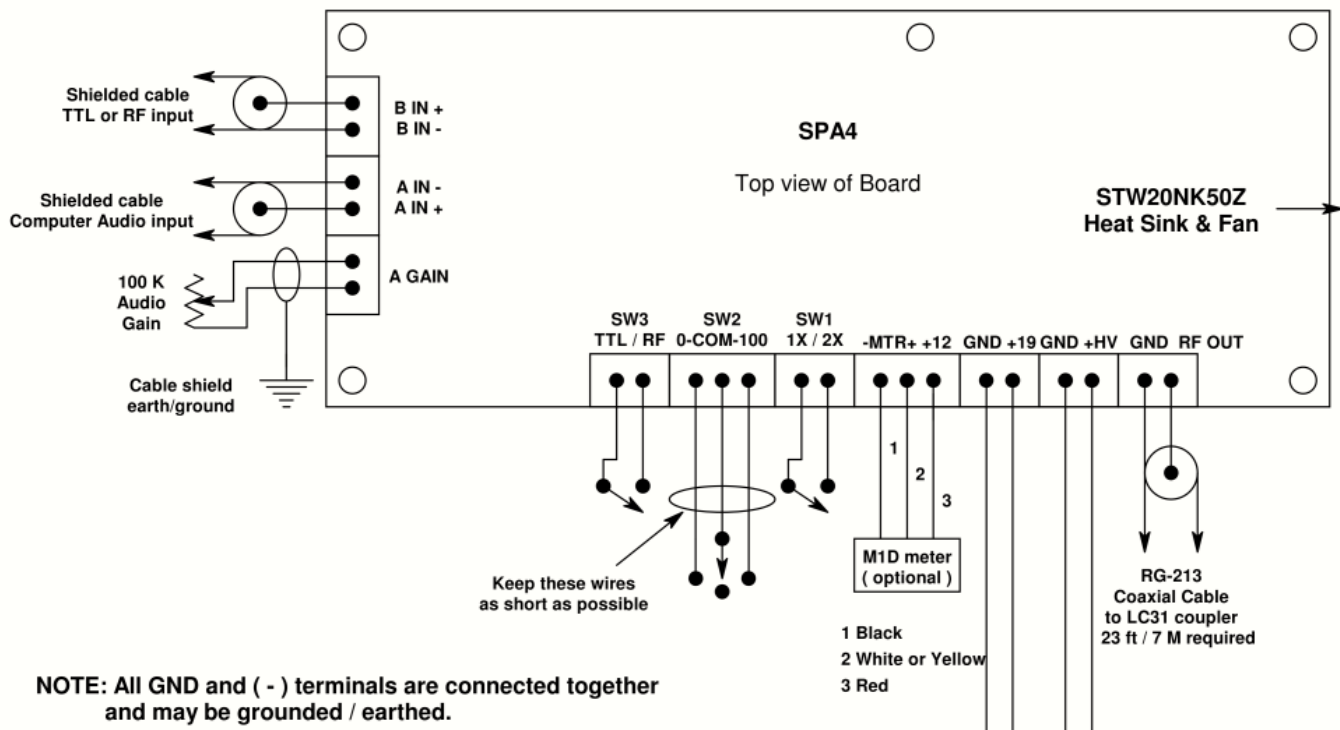

Five power supplies are shown for a total amplifier DC voltage of 95 volts. More power supplies may be added as required for higher voltages. The maximum DC voltage allowed is 190 volts. The power supply system should be current limited to about 3.5 amperes.

Figure 1

A typical system setup using the SPA4.

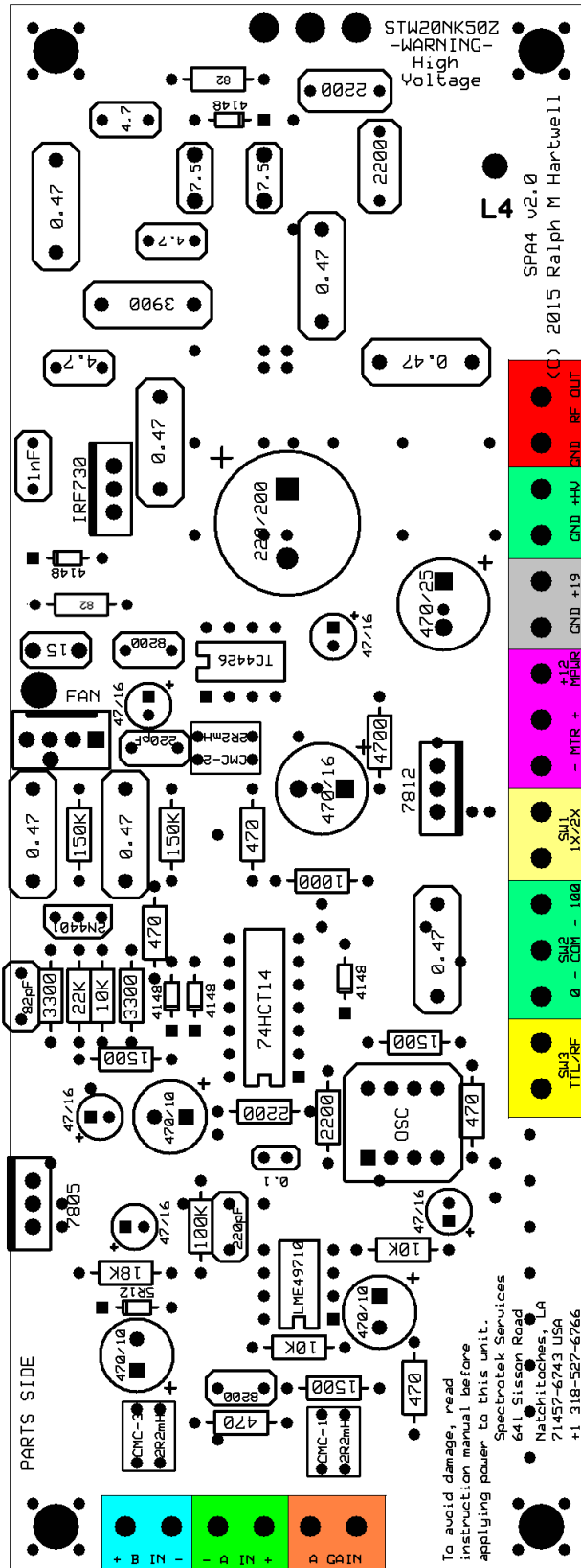

Figure 2 - SPA4 Terminal Block Connections & Component Identification.

TERMINAL BLOCK CONNECTIONS:

Please refer to Figure 2 on the previous page for the location of the various connections between the controls and the SPA4 circuit board.

All connections to the SPA4 are made by using the small screw terminals that are located in the plastic terminal blocks that are mounted along the edges of the circuit board. These will accept either solid or stranded conductor wire up to AWG 14 in size.

When installing the wires, do not excessively tighten the screws. This will avoid damaging the screw threads in the terminal block. Remove about 1/4" or 4 mm of insulation from the end of each wire. Insert the stripped wire end into the hole in the terminal block, and then gently tighten the screw to clamp the wire in place.

This diagram shows the relative position of the various connectors on the SPA4. They have been color coded for ease of identification. Note that the terminal blocks on the SPA4 itself will usually all be the same color.

(+ B IN -) Blue

Connections to this input must be made using a shielded cable. The shield connects to the (-) terminal, and the center wire or core of the cable connects to the (+) terminal.

This connection accepts sine, triangle or square wave audio signals with a frequency range of 1 to 400,000 Hz, or a 3.1 MHz RF carrier that is square wave modulated by TTL signals in the frequency range of 1 to 400,000 Hz. Signals must be within the range of 3.5 to 5.5 volts, peak-to-peak.

(+ A IN -) Light Green

Connections to this input must be made using a shielded cable. The shield connects to the (-) terminal, and the center wire or core of the cable connects to the (+) terminal.

This connection accepts only sine or triangle wave audio signals having a frequency range of 10 to 30,000 Hz in the 2X mode, or 10 to 200,000 Hz in the 1X mode. Signals must be within the range of 0.4 to 10.0 volts, peak-to-peak.

(A GAIN) Light Orange

Connect a 10 K ohm potentiometer across these terminals.

The function of the potentiometer is to adjust the duty cycle of the modulated RF output of the SPA4 when the SPA4 is using sine or triangle audio signals connected to the INPUT A terminal block.

Leave these connections open to obtain the maximum audio gain from the SPA4. (Lowest audio input voltage required.)

Short these connections together to obtain the lowest audio gain from the SPA4. (Highest audio input voltage required.)

Using a length of 2-wire shielded audio cable and a 10 K ohm linear taper potentiometer, and connect the center (wiper) terminal of the potentiometer to either connection of the GAIN terminal block. **Although the SPA4 v2.0 incorporates substantial self-interference protection, the use of a shielded wire is recommended to help prevent possible RF feedback and erratic operation of the SPA4.**

Connect one of the two outer terminals of the potentiometer to the other connection of the GAIN terminal block.

If shielded wire is used, the shield wire should be connected to the ground connection of the AUDIO terminal block.

If desired, a ¼ watt, fixed resistor (of a value selected by the user) may be installed instead of the potentiometer. This resistor will reduce set the maximum audio input voltage that the SSQ-2 will accept. In most cases, use of the 10 K potentiometer is preferred.

(SW3 TTL / RF) Dark Yellow

Connect a single pole, single throw (SPST) switch to this connector block.

When using a square wave modulated 3.1 MHz carrier from an external frequency generator that is connected to INPUT B of the SPA4, switch SW3 must be CLOSED. Closing SW3 will disable the on-board 3.1 MHz carrier oscillator of the SPA4 and allow the externally generated carrier signal to be amplified.

When using an audio signal that is connected to INPUT A of the SPA4, or when using a frequency signal that is WITHOUT an external 3.1 MHz carrier, then switch SW3 must be OPEN in order to provide the necessary 3.1 MHz carrier for the SPA4.

WARNING! – Closing SW3 and disabling the on-board carrier oscillator will cause damage to the IRF730 driver transistor if an audio modulation signal is sent to the SPA4 without an external 3.1 MHz carrier signal present at the same time.

(SW2 0 – COM - 100) Dark Green

Connect a single pole, double throw (SPDT) switch to this connector block.

The center arm of the switch goes to the center connection of the terminal block. The two outer connections of the switch go to the two outer connections of the terminal block. **If the wires are longer than about 12 inches / 30 cm it is recommended that they be shielded to prevent possible waveform distortion at high modulation frequencies.**

When the (0) and (COM) connections of this switch are closed, the SPA4 will operate in the 0 to 50% duty cycle mode. **This position is only used with frequency signals that are sent to INPUT A of the SPA4.**

When the (100) and (COM) connections of this switch are closed, the SPA4 will operate in the 50% to 100% duty cycle mode. **This position is only used with frequency signals that are sent to INPUT A of the SPA4.**

When this switch is set so that it is in the center (off) position, the audio processing section and INPUT A of the SPA4 is disconnected, and INPUT B becomes the active input.

(SW1 1X / 2X) Light Yellow

Connect a single pole, single throw (SPST) switch to this connector block.

This switch allows operation in either the X2 mode (switch open) or the X1 mode (switch closed.)

This switch is only used when audio signals are sent to INPUT A of the SPA4.

(- MTR + +12 MPWR) Pink

There are three connections on the MTR terminal block.

Connect the duty cycle meter type M1-D to the MTR terminal block. Note that depending on which type of meter you have, the meter wires will be either black, white and red, or black, white and yellow.

The **BLACK** negative ground wire from the M1-D meter connects to the **-MTR** connection of the MTR terminal block.

The **WHITE** duty cycle signal wire from the M1-D meter connects to the **+MTR** connection of the MTR terminal block

The **RED** or **YELLOW** meter power supply wire from the M1-D meter connects to the **+12 MPWR** connection of the MTR terminal block.

CAUTION: Accidentally connecting either the black or the white wire to the MPWR terminal may destroy the meter.

If you are using a high impedance voltmeter or a micro ammeter instead of duty cycle meter M1-D, then you should connect a 500 Ohm potentiometer between the (+) and (-) MTR terminal block. The meter will connect between the (-) connection and the wiper of the potentiometer.

(GND +19) Gray

This terminal block is used to connect a fixed voltage 19 volt DC power to the logic section, RF driver stage and the heat sink cooling fan of the SPA4.

Connect the +19 volt wire from your power supply to the +19 terminal. Connect the power supply negative wire to the GND terminal.

(GND +HV) Light Green

This terminal block is used to connect an adjustable high voltage DC power supply to the RF power amplifier of the SPA4.

Connect the + high voltage wire from your power supply to the +HV terminal. Connect the power supply negative wire to the GND terminal. It is useful to install a 2 ampere current meter in series with the positive wire. This allows monitoring of the current drawn by the amplifier during operation.

Note that the negative (-) connections of the PA PWR and the logic PWR terminal blocks are common, that is, they are connected together inside the circuit board..

(GND RF OUT) Red

This terminal block is where the RF output of the SPA4 appears.

Connection to this block requires the use of a shielded 50 Ohm impedance coaxial cable between the terminal block and the matching system that will be connected to the plasma tube. For full power operation at 150 watts and higher, type RG-213 cable is required. For low power systems of less than 150 watts, type RG-58 coaxial cable may be used.

Connect the center wire or core of the coaxial cable to the RF OUT terminal.

Connect the shield of the coaxial cable to the GND terminal.

Note that only solid dielectric, 50 Ohm coaxial cable with a length of 23 feet / 7 meters may be used. The cable type and length is critical for proper amplifier tuning and operation. Use of incorrect cable type or length may cause amplifier failure.

Mounting the SPA4

The SPA4 may be mounted in a metal, plastic, or wood enclosure if desired. Although it is not normally necessary to provide shielding for the SPA4, the use of a metal mounting plate or enclosure is suggested.

Mounting holes located in the corners of the SPA4 are provided for mounting the board. If the SPA4 is mounted next to a metal surface, then the use of standoff supports is advisable to prevent unwanted short circuits between the underside of the SPA4 and the metal mounting surface.

Metal spacers or standoffs should be used to maintain ground / earth continuity between the SPA4 and the mounting plate.

It is very important to prevent outside RF energy, such as from an operating plasma tube, from entering the SPA4. Unwanted RF ingress will cause erratic operation and incorrect modulation of the RF carrier.

The most common point of entry for unwanted RF energy is via the audio input cable. Using a shielded audio cable is a must. Make sure the cable is routed well away from the high-power RF components of the system. Use the shortest length of audio cable possible.

In severe cases of interference, looping the audio cable a half-dozen times through a ferrite toroid will usually eliminate the problem. Place the toroid as close to the input connections of the SSQ-2F as possible. Use a toroid core with material type 31 for best results.

Metering the Square Wave Duty Cycle When Using INPUT A

The use of a Duty Cycle Meter is necessary when INPUT A of the SPA4 is used. INPUT A is used only when frequencies are being generated by a computer, or played back from some device such as a CD player or an MP3 player. When INPUT B of the SPA4 is used, the duty cycle meter is NOT necessary. If a duty cycle meter is connected during operation with INPUT B in use, the duty cycle meter will indicate the duty cycle which will be controlled by the external frequency generator.

The use of a duty cycle meter is optional, but it is recommended since it allows the operator who does not have an oscilloscope to be able to easily adjust the duty cycle of the modulated RF output of the SPA4 when the INPUT A is in use.

The SPA4 has been designed to work with the M1-D duty cycle meter, but you may make your own duty cycle meter if you prefer. When it has been calibrated according to the instructions given here, your meter will read the duty cycle as accurately as the M1-D.

Please refer to the section of this manual titled “TERMINAL BLOCK CONNECTIONS” for information about connecting the M1-D duty cycle meter to your SPA4.

Should you choose to use your own meter, it will be necessary to calibrate it to read correctly with your SPA4. The metering circuitry of the SPA4 has been designed to operate correctly with the M1-D meter.

Although the type M1-D meter is furnished pre-calibrated, you may chose to do a calibration of the M1-D meter to your particular SPA4. This ensures the utmost accuracy when measuring the duty cycle of the modulated RF output of the SPA4. Follow the calibration instructions on the next page.

Making your own Duty Cycle Meter

It is possible to make your own duty cycle meter. You will require a DC meter with a full scale reading of between 50 uA and 1 mA. It will be helpful if the meter scale indicates 0 to 100. The scale reading will then correspond directly to the duty cycle after your meter is calibrated.

Connect a 500 ohm potentiometer between the (+) and (-) MTR terminals. This potentiometer is required to provide the correct circuit loading and time constant for your meter. Connect the meter between the (-) MTR connection and the center connection (wiper) of the potentiometer.

Calibrate your duty cycle meter by following these instructions for calibrating the M1D meter.

SPA4 Setup before calibrating the M1-D.

Set switch SW1 to OPEN

Set switch SW2 to 100. (50% to 100% duty cycle)

Set switch SW3 to OPEN.

Your audio frequency generator should be set to a frequency between 1000 and 10,000 Hz, with a sine wave output.

Connect your frequency generator to the INPUT A of the SPA4.

There should be no connection to the INPUT B of the SPA4.

Connect DC power to the +19 terminal block of the SPA4.

NOTE: Do not apply any DC power to the +HV terminal block of the SPA4

This will allow the logic circuits and the audio processing circuits of the SPA4 to operate, but the SPA4 will not produce any RF output. RF output is not required to adjust the duty cycle meter M1-D

Duty Cycle Meter Calibration Procedure

With DC power applied to the +19 terminal block and with no audio input (zero voltage) applied to the AUDIO terminal block of the SPA4, meter M1-D should read zero.

Gradually increase the audio voltage to the INPUT A of the SPA4. As you increase the audio voltage input to the SPA4, the M1-D meter will begin to indicate an increasing reading.

Continue to increase the audio voltage input to the SPA4 until the meter reading stops increasing. This should be somewhere close to a reading of 100 or possibly slightly higher.

If the meter reading is not exactly 100, then carefully adjust the calibration potentiometer that is located on the back of the M1-D meter until the meter displays a reading of 100.

This completes the calibration of the M1-D duty cycle meter to your SPA4.

SETUP AND GENERAL OPERATION OF THE SPA4

INPUT A - when used for computer-type audio signals

Suitable frequency generators include:

Laptop and desktop computers having a line level output or headphone jack,

CD player,

DVD player,

MP3 player,

Most cell phones.

UDB1108S,

Spooky2,

GB-4000,

F-165, F-175 and other F-series units,

PROGEN II 4050,

Or any other frequency generator that is capable of producing a sine or triangle wave output.

Acceptable input signal levels are between 0.25 to 10 volts peak-to-peak.

The INPUT A audio processor circuitry of the SPA4 has been designed to accept a sine wave frequency generated by a computer. Most computer sound systems are unable to reproduce sharp-edged square waves above even a few hundred Hz, or even sine wave audio signals above 22,000 Hz, thus making computer sound cards virtually unusable when square wave modulated Rife systems are used.

Because most people will use computer sound cards to generate the required audio frequencies, all references to computer sound cards in this document also refer to audio waveforms that are generated by MP3 players, CD, or DVD players and the like. It should be noted that MP3 players and CD and DVD players also suffer from the same inability to properly handle square waves.

The inability to generate sharp-edged square waves is a serious problem. In order to generate the higher frequency harmonic energy required for a Rife system to work properly, the leading and trailing edges of the square wave must be "sharp," that is, it must have a very fast rise and fall time.

To solve this problem, the SPA4 has been designed to accept sine wave audio frequencies within the frequency range that the computer sound card can generate. The SPA4 then doubles those frequencies and converts them to clean square waves before modulating the 3.1 MHz carrier wave.

By doubling the input frequency, modulation frequencies of up to 44,000 Hz may be obtained using a standard computer sound card as the signal source. This allows the 3.1 MHz carrier to be modulated across the entire 500 to 25,000 Hz frequency range required for the 3.1 MHz Rife sweep. Because of the frequency doubling action of the SPA4, the computer sound card need only generate sine wave signals within the frequency range of 250 to 12,500 Hz, which is within the range of any computer sound card.

The SPA4 audio frequency doubling system allows the researcher to be able to implement the 3.1 or 3.3 MHz Rife Sweep protocol as outlined in the document posted at:

http://rifevideos.com/dr_rife_and_philip_hoylands_3.3mhz_sweep.html

This sweep protocol calls for the use of a 3.1 or 3.3 MHz carrier that is 100% modulated by a square wave that slowly sweeps between 500 and 25,000 Hz. Specific “spot” frequencies may also be used.

Note that the SPA4 may be configured to either double (2X Mode) or not double (1X Mode) the audio frequency it receives on INPUT A.

Maximum Modulation Frequency of the SPA4

The maximum recommended modulation frequency when using the SPA4 is 400,000 Hz (400 KHz.) on INPUT B.

Note that there is a risk of destroying the STW20NK50D at high modulation frequencies and high power levels.

CAUTION: When the modulation frequency begins to exceed about 400 KHz, excessive RF voltages will be developed in the SPA4’s tank circuit and the LC31 coupler. These voltages may cause the STW20NK50Z MOSFET in the SPA4 to fail.

INPUT A:

The following are the setup parameters for the SPA4 when using Sine or Triangle frequencies from a computer connected to INPUT A.

For use with sine, triangle, or square wave audio frequencies from 10 to 40,000 Hz.

Please do not exceed the maximum allowable peak voltage of + or - 12 volts at INPUT A of the SPA4 to prevent damage to audio input amplifier U1. The audio signal may be offset by a maximum level of +6 or -6 volts DC without damaging input amplifier U1.

The SPA4 will ignore any DC offsets, as long as they are constant. A varying DC offset voltage may be interpreted by the SPA4 as a change in the audio input level and will result in a change in the modulation duty cycle.

SPA4 configuration to DOUBLE the audio frequency input: (X2 mode)

SW1 is set to the OPEN / OFF position.

SW2 is set to the 0 to 50 position for an output duty cycle of 50% or less, or,

SW2 is set to the 50 to 100 position for an output duty cycle of 50% or more.

SW3 is set to the OPEN / OFF position. **THIS IS THE RECOMMENDED SETTING.**

SPA4 configuration to pass through the audio frequency input not doubled: (X1 mode)

SW1 is set to the CLOSED / ON position.

SW2 is set to the 0 to 50 position for an output duty cycle of 50% or less, or,

SW2 is set to the 50 to 100 position for an output duty cycle of 50% or more.

SW3 is set to the OPEN / OFF position. **THIS IS THE RECOMMENDED SETTING.**

INPUT A:

The following are the setup parameters for the SPA4 when using Square Wave frequencies from an external frequency generator connected to INPUT A.

Note that in most cases, if the frequency generator can output a TTL level signal, better performance will be obtained by connecting the frequency generator to the SPA4 INPUT B set for Mode 2.

When operating with square wave audio signals, increasing the audio signal level excessively or turning the audio gain potentiometer too high will result in an erratic square wave output.

The SPA4 determines when to turn the RF carrier on and off by sensing the rate of amplitude change of the input audio signal. While sine and triangle waves have smooth rise and fall times, square waves are very abrupt, and the SPA4 cannot do anything except sense the rising and falling edges of square waves. This means that using square waves as an audio input will cause the modulation signal from the SPA4 to follow the rising and falling edges of the square wave, but with much faster rise and fall times.

Because of this, the frequency-doubling mode of the SPA4 will not work with square wave audio input signals. The output will always be in the X1 Mode.

NOTE: The duty cycle of the modulated RF output of the SPA4 will always follow the duty cycle of the input square wave signal.

If a square wave audio signal with other than a 50% duty cycle is sent to the input of the SPA4, the polarity (and hence the duty cycle ratio) of the modulated RF output may be inverted by reversing the position of switch SW3. The normal position of SW3 is the 50-100% position. Setting SW3 to the 0-50% setting will invert the duty cycle of the signal.

For instance, if a square wave audio signal with a duty cycle of 80% is connected to the input of the SPA4, the modulated RF output of the SPA4 will be ON for 80% of the modulation cycle and OFF for the remaining 20%. Reversing SW3 will result in the RF carrier being ON for 20% of the modulation cycle and OFF for the remaining 80%.

INPUT B: (Mode 1)

The following are the setup parameters for the SPA4 when using an external frequency generator that can output a 3.1 MHz RF carrier that is modulated with square wave frequencies between 1 to 400,000 Hz.

Suitable frequency generators include:

Spooky2,

GB-4000,

F-165, F-175,

Any other frequency generator capable of producing a 5 volt peak-to-peak, square wave modulated, 3.1 MHz RF signal.

CAUTION: Loss of the external carrier signal when the audio signal is present may cause damage to the IRF730 driver transistor and failure of the amplifier.

SPA4 configuration:

SW1 is not used in this mode. Its position does not matter.

SW2 to set to the CENTER / OFF position.

SW3 to set to the CLOSED / ON position.

INPUT B: (Mode 2)

The following are the setup parameters for the SPA4 when using an external frequency generator that can output TTL square, sine, or triangle wave frequencies between 1 to 400,000 Hz.

The duty cycle of the modulated RF output of the SPA4 will follow the duty cycle of the input frequency set by the external frequency generator.

Suitable frequency generators include:

UDB1108S,

Spooky2,

GB-4000,

F-165, F-175 and other F-series units,

PROGEN II 4050,

Any other frequency generator capable of producing a 5 volt peak-to-peak, square, sine, or triangle wave output.

SPA4 configuration:

SW1 is not used in this mode. Its position does not matter.

SW2 to set to the CENTER / OFF position.

SW3 to set to the OPEN / OFF position.

Input Voltage for a square wave signal on INPUT B (Mode 2)

A minimum of 2.25 Volts Peak to Peak (VPP) is required to trigger the SPA4. The voltage should not exceed 6.0 volts to avoid damage to the input circuits in the SPA4. Ideally, the drive signal should be a square wave TTL signal, which has a voltage swing of 0 to +5 Volts.

Modulation Duty Cycle vs. input Frequency with a square wave modulation signal on INPUT B (Mode 2)

For a duty cycle of 1% to 50%: 1 Hz to 400 KHz

For a duty cycle of 1% to 89%: 2 Hz to 400 KHz

For a duty cycle of 1% to 98%: 3 Hz to 400 KHz

For a duty cycle of 1% to 99%: 4 Hz to 400 KHz

Input Voltage for a sine wave signal on INPUT B (Mode 2)

A minimum of 2.5 Volts Peak to Peak (VPP) is required to trigger the SPA4 when using sine waves. The maximum allowable sine wave voltage input should be limited to no more than 7.0 Volts peak to peak to prevent possible damage to the input circuit of the SPA4. When using sine waves, the duty cycle of the modulated output of the SPA4 will be limited to the range of 20% to 58%.

Modulation Duty Cycle percent vs. input voltage with a sine wave modulation signal on INPUT B (Mode 2)

2.5 VPP for 20% duty cycle (Minimum duty cycle % possible with sine waves)

3.12 VPP for 37% duty cycle (for Maximum Sidebands)

5.0 VPP for 50% duty cycle (for Normal Operation)

5.58 VPP for 58% duty cycle (Clipping of input signal occurs above this level)

DC power supply voltage for the SPA4 when used with various Bill Cheb Plasma Tubes (Listed in order of tube power handling ability)

Cheb SSQ-PT - With modulation frequencies from 0 to 400,000 Hz (400 KHz,) the maximum DC supply voltage to the SPA4 should be limited to 76 volts or less to avoid damage to the Phanotron tube. This will result in an approximate power of about 30 watts average power or 70 watts peak power. **The recommended operating voltage for this tube is 57 volts or less.**

Cheb 5-inch Phanotron tube - With modulation frequencies from 0 to 400,000 Hz (400 KHz,) the maximum DC supply voltage to the SPA4 should be limited to 100 volts or less to avoid damage to the Phanotron tube. This will result in an approximate power of about 75 watts average power or 150 watts peak power. **The recommended operating voltage for this tube is 114 volts or less.**

Cheb 8-inch Phanotron tube - With modulation frequencies from 0 to 400,000 Hz (400 KHz,) the maximum DC supply voltage to the SPA4 should be limited to 115 volts or less to avoid damage to the Phanotron tube. This will result in an approximate power of about 125 watts average power or 250 watts peak power. **The recommended operating voltage for this tube is 115 volts or less.**

Cheb SSQ-ST - With modulation frequencies from 0 to 40,000 Hz (40 KHz), the maximum DC supply voltage to the SPA4 should be limited to 133 volts or less to avoid damage to the SSQ-ST or the SPA4. This will result in an approximate power of about 175 watts average power or 350 watts peak power. Using DC voltages in excess of this value may cause the STW20NK50Z MOSFET in the SPA4 to fail. **The recommended operating voltage for this tube is 133 volts or less.**

Cheb SSQ-ST - With modulation frequencies from 40,000 to 400,000 Hz (400 KHz,) the maximum DC supply voltage to the SPA4 should be limited to 133 volts or less to avoid damage to the SPA4. This will result in an approximate power of about 135 watts average power / 270 watts peak power. Using DC voltages in excess of this value may cause the STW20NK50Z MOSFET in the SPA4 to fail. **The recommended operating voltage for this tube is 133 volts or less.**

Cheb SSQ-BAT - With modulation frequencies from 0 to 40,000 Hz (40 KHz,) the maximum DC supply voltage to the SPA4 should be limited to 190 volts or less to avoid damage to the SPA4 amplifier. This will result in an approximate power output to the tube of about 250 watts average power / 500 watts peak power. Using DC voltages in excess of this value may cause the STW20NK50Z MOSFET to fail. **The recommended operating voltage for this tube is 152 volts or less.**

Cheb SSQ-BAT - With modulation frequencies from 40,000 to 400,000 Hz (400 KHz,) the maximum DC supply voltage to the SPA4 should be limited to 170 volts or less to avoid damage to the SPA4 amplifier. This will result in an approximate power output to the tube of about 250 watts average power / 500 watts peak power. Using DC voltages in excess of this value may cause the STW20NK50Z MOSFET to fail. **The recommended operating voltage for this tube is 133 volts or less.**

Driving a Plasma Tube from the SPA4

About Driving Plasma Tubes

Because the SPA4 can provide RF power levels of up to 500 watts peak power, it is possible to drive a large plasma tube from the SPA4 without the need for an additional amplifier. However some form of coupling or matching system will be needed to match the 50 ohm output impedance of the SQ-2F to the varying load presented by the plasma tube.

Plasma tubes are of two basic types, internal electrode and external electrode tubes. Internal electrode tubes are easier to light up because their electrodes are in intimate contact with the gas in the tube. Their drawback is that the internal electrodes absorb a lot of power during operation and they may become extremely hot, even to the point of glowing red. When this happens, the electrodes will begin to give off gas (outgas) and this may contaminate the gas mixture in the tube. This result is an off-color glow or outright failure of the tube to light properly, causing amplifier failure. Because of the heat limit of the internal electrodes, these internal electrode tubes are limited in the maximum amount of power they can handle without damage to the tube.

To solve this electrode overheating problem and to allow plasma tube operation at higher power levels, many experimenters are using external electrode tubes. An external electrode tube generally has some form of metallic electrode wrapped around the outer ends of the tube. These electrodes may be made in the form of a wrap-around collar, The “collar” electrode, such as the Spectrotek types E1(W), E2(W), E3(W), and E4(W), a spring-like wire wrap, or a piece of metal screen wrapped around the ends of the tube. These electrodes are then connected to the source of RF energy, just as would be the electrodes of an internal electrode tube.

External electrodes transfer RF power to the gas in the tube by capacitive action. An AC current can pass through a capacitor, but not a DC current. The external electrode forms one plate of the capacitor, and the ionized gas in the tube forms the other electrode. The glass wall of the tube serves as the dielectric medium of the capacitor.

When a Rife plasma system uses an RF (AC) carrier to drive the tube, external electrodes usually work quite well. They are limited in their power handling only by the maximum power the tube walls can withstand without melting. Heating of the tube wall occurs from two sources: the dielectric loss of the glass wall, and direct heating by the hot, ionized gas inside the tube.

Generally, well before the point of melting the glass is reached, the gas inside the tube will heat up enough so that the tubes internal gas pressure will increase, causing the tube to lose color and become dimmer, thereby alerting the operator to the fact that the tube is too hot. An external electrode tube can be built to handle ten times or more the power that the same size internal electrode tube can withstand.

RF Coupling Systems

Commercial Antenna Tuners are not generally satisfactory for use with the SPA4. The use of the Spectrotek Services type LC31 coupler is recommended. A technical description of the coupler system may be found at http://rife-beam-ray.com/3.1mhz_match/index.htm

Mounting the SPA4 and the HS2 Heat Sink / Cooling Fan Assembly

If you have purchased an assembled SPA4 amplifier, it will be furnished already mounted on the HS2 heat sink / cooling fan assembly. The HS2 heat sink provides the proper cooling to allow the SPA4 to operate at full rated power. Please be sure that nothing obstructs the flow of cooling air entering the fan or the warm discharge air leaving the heat sink.

When the SPA4 is mounted on the HS2 heat sink, the result is a compact module that allows for easy incorporation of the SPA4 into a complete plasma tube RF drive system.

The HS2 heat sink with the SPA4 attached to it may be mounted in place in your system by the use of a clamp, a bracket, or some type of strap that will hold the heat sink assembly firmly in place. It is important that the airflow through the heat sink not be obstructed in any manner. A plentiful supply of cool air must be allowed to enter the fan and the heat sink assembly. Likewise, the warm exhaust air must be allowed to freely exit the area of the heat sink.

VERY IMPORTANT !!

If the unit is placed in an enclosure, it is advisable to mount the air intake side of the fan immediately adjacent to an opening in the enclosure where fresh air from outside the enclosure can enter the fan. An unrestricted exhaust opening must be placed somewhere in the wall of the enclosure to let the warm air escape. The size of the exhaust opening must be equal to or larger than the opening for the cooling air inlet. Any restriction of the cooling air entering the heat sink assembly will result in overheating of the SPA4 amplifier with possible failure.

The Cooling Fan on the SPA4

The fan on the SPA4 heat sink is powered by the voltage regulator of the SPA4 circuit board, so that there is no need for a separate power supply to operate the fan.

The fan is very quiet and does not make much noise. It is easy to forget that it is running while you are working with your system. Please be careful not to allow your fingers or anything else to come in contact with the fan blades while the fan is in operation. Accidentally hitting the fan blades with your finger or a hard object such as a screwdriver may break one of the blades off of the fan hub. If this happens, it will be necessary to replace the fan.

Replacing the STW20NK50Z on the SPA4

Although the STW20NK50Z MOSFET that is used in the SPA4 is a very rugged device, it is still possible for it to fail if the SPA4 is operated under an excessive load or under improper operating conditions. Should this happen, it will be necessary to replace the STW20NK50Z MOSFET. This is not particularly difficult to do. Please read the following sequence of operations before attempting to replace the transistor.

1 – Using a small flat-blade screwdriver, carefully loosen the three clamping screws in the terminal strip that fastens the leads of the STW20NK50Z MOSFET in place.

2 – Remove the two 6-32 x 3/8” Phillips head screws and nuts that hold the SPA4 to aluminum mounting bars that are attached to the heat sink. Place the screws and nuts where they will not become lost.

3 – Carefully remove the SPA4 from the heat sink assembly.

4 – Using a Phillips head or a flat-blade screwdriver, unscrew the 6-32 x 3/4” screw and flat washer that clamps the STW20NK50Z MOSFET against the heat sink. Place the screw and flat washer where they will not become lost.

5 – Carefully remove the defective STW20NK50Z MOSFET from the heat sink.

Because the MOSFET will be probably stick to the Bergquist thermal pad that is between the MOSFET and the heat sink, you may have to use a pair of pliers to carefully pull the defective MOSFET away from the thermal pad. Gently, but firmly, grasp the sides of the defective MOSFET with the pliers and “rock” the MOSFET from side to side until it breaks free of the thermal pad. Be sure not to damage the thermal pad. It is very soft, and scratches or punctures easily. If it is damaged in any way, it will be necessary to replace it with a new thermal pad of the same type before installing the new MOSFET against the heat sink.

6 – Take the new STW20NK50Z MOSFET and carefully bend its leads into the same shape as the leads of the defective MOSFET.

Do not bend them too sharply or they may weaken and break off at the bend.

7 – Carefully trim approximately 1.5 mm from the end of the pins of the MOSFET. Be careful not to remove too much of the pin length.

8 – Using a small piece of lint free cloth and 100% isopropyl alcohol, gently clean the surface of the Bergquist thermal pad and the metal surface of the STW20NK50Z MOSFET that will mount against the thermal pad.

9 – Carefully position the replacement MOSFET against the surface of the thermal pad, and press it firmly against the thermal pad.

10 – Using the 6-32 screw and the flat washer, clamp the new MOSFET firmly against the Bergquist thermal pad and heat sink. Do not allow the MOSFET and the thermal pad to twist sideways while tightening the screw.

Although it may seem that the length of the 6-32 screw is a longer than it needs to be, it is necessary to use a long screw in order to spread the clamping force across a number of screw threads that are tapped in the heat sink. The screw must be tightened very firmly against the transistor. The flat washer must be used to spread the clamping force over the transistor body and prevent cracking of the transistor case.

11 – Carefully position the SPA4 circuit board so that the leads of the new STW20NK50Z enter the holes of the mounting block on the SPA4. Be sure that you do not bend the leads of the STW20NK50Z in the process.

12 - When you observe that the leads have entered the mounting block correctly, then you may replace the two Phillips head screws and nuts that clamp the SPA4 circuit board to the aluminum mounting bars that are attached to the heat sink.

13 – Gently, but firmly, tighten the three clamp screws that hold the leads of the STW20NK50Z to the SPA4 circuit board. **Do not omit this step or the MOSFET may be destroyed during operation or the amplifier may refuse to function.**

14 – Inspect your work to make sure that there are no short circuits, metal particles, or anything else that might interfere with the proper operation of the SPA4. If all is correct, you may replace the heat sink assembly and the SPA4 in your system and resume normal operation.

Electrically Insulating the STW20NK50Z from the heat sink

This section only applies when it is necessary to replace the output transistor on the SPA4, or if you are using your own heat sink.

Because the STW20NK50Z generates a considerable amount of heat in a small package, a high quality thermal pad is required for safe operation of the STW20NK50Z.

The STW20NK50Z is operating at both a high DC voltage and a high RF voltage, therefore it is necessary to insert some form of electrical insulator (thermal pad) between the STW20NK50Z and the heat sink base plate. This insulator must be made of some material which both insulates the high voltage and at the same time it must be a good conductor for heat to allow the heat to flow from the STW20NK50Z to the heat sink base plate. Unfortunately, most materials which are good insulators for electricity are also good insulators for heat. Manufacturers have gone to a great deal of trouble and expense to produce devices, commonly referred to as "thermal pads" which will function properly.

The Bergquist SSPA4000-0.015-00-104 thermal pad is recommended for use with the SPA4. If this pad is not available, a Wakefield 174-9-250P thermal pad may be substituted. However, the heat transfer capability of the Wakefield pad is approximately 50% of the Bergquist pad. Therefore when using the Wakefield thermal pad, the SPA4 should not be operated above 300 Watts output with modulation duty cycles above 70%.

Before attaching the STW20NK50Z and the Bergquist thermal pad to the heat sink, use a liquid cleaning solution, such as 100% isopropyl alcohol and a lint free rag to carefully clean the underside of the STW20NK50Z and the area of the heat sink where the STW20NK50Z is to be mounted. Make sure that both sides of the thermal pad are very clean. Be sure that there are no stray particles of metal, lint, fiber, or other materials on the surface of the transistor, the thermal pad, or the heat sink before mounting the STW20NK50Z to the heat sink.

When installing the thermal pad do NOT use any paste type thermal compound. Using paste type thermal compound will cause decreased heat transfer and may cause damage to the thermal pad and/or destruction of the STW20NK50Z.

SPECIFICATIONS:

DC Power Supply Input:

- SPA4 Logic circuits +19 to +22 volts DC filtered and regulated, at 0.75 Ampere.
- SPA4 RF output amplifier +12 to +190 volts DC maximum, filtered and regulated at 2.5 amperes maximum, the actual current required varies with power output and modulation duty cycle.

Input Audio Signal Waveform and Frequency Range:

- Sine, triangle, or square wave from a computer or various signal and frequency generators.
- Frequency range when using INPUT A, X2 mode: 10 to 30,000 Hz (30 KHz.)
- Frequency range when using INPUT A, X1 mode: 6 to 200,000 Hz (200 KHz.)
- Frequency range when using INPUT B: 1 to 400,000 Hz (400 KHz.)
- Direct input modulated 3.1 MHz carrier using INPUT B.

Modulation Modes - INPUT A:

- X1 Mode - The modulation frequency equals the input audio frequency using sine, triangle, or square waves.
- X2 Mode - The modulation frequency equals TWICE the input audio frequency using sine or triangle waves only.

Modulation Frequency Ranges - Input A, X1 Mode:

Input Audio Frequency Range in X1 Mode, @ 50 - 7200 mV p/p Input Level with a Sine or Triangle Wave Input Signal:

- Low - 6 Hz.
- High - 200,000.
- This will square wave modulate the carrier over the range of 4 to 200,000 Hz.
- Usable frequency range from 4 to 400,000 Hz with increased audio input level.
- This will square wave modulate the carrier over the range of 4 to 400,000 Hz.

Modulation Frequency with a Square Wave input signal of 50 - 7200 mV p/p:

Note: Square wave audio is usable in X1 Mode only, and the duty cycle follows the duty cycle of the input signal to the SPA4.

- Low - 75 Hz.
- High - 200,000 Hz.
- This will square wave modulate the carrier over the range of 75 to 200,000 Hz.

Modulation Frequency Ranges – Input A, X2 Mode:

Input Audio Frequency Range in X2 Mode @ 40 - 7200 mV p/p input level with a Sine or Triangle Wave Input Signal:

- Low - 40 Hz.
- High - 30,000 Hz at maximum audio gain, or 60,000 Hz at minimum audio gain.
- This will square wave modulate the carrier over the range of 80 to 60,000 Hz or 80 to 120,000 Hz.

NOTE: In the X2 Mode, when using a sine or triangle wave audio input, the output of the Controller Board will maintain a 50% duty cycle ratio to within 10% or less across the input frequency range of 40 to 30,000 Hz at maximum audio gain, or 40 to 60,000 Hz at minimum audio gain. This allows unattended operation of the equipment without the need for constant audio gain adjustments when using an audio sweep signal generated by a computer sound card. It is necessary to maintain low source impedance and a constant voltage as the audio frequency changes during the sweep.

Modulation Modes - INPUT B:

- Square wave modulation of the internally generated 3.1 MHz carrier by a square, sine or triangle wave, TTL level input signal or,
- Amplification of an externally modulated, 3.1 MHz TTL level input signal.

Carrier Frequency:

- 3.1 (standard) or 3.3 MHz. Frequency to be specified at time of order. The carrier frequency may be changed by the user by replacing the plug-in oscillator module with a module of a different frequency.
- Customer requested frequencies in the range of 2.6 MHz to 3.7 MHz are available on special order.

RF Power Output:

- The SPA4 will produce up to 500 watts peak power, or 250 watts average power as measured across a 50-ohm load when the carrier is modulated by a 50% duty cycle square wave.

Warranty

All our products carry a one (1) year warranty against manufacturing defects. Mechanical damage is not covered; for instance, if you dropped it on the floor and then accidentally stepped on it. For warranty service, you pay shipping to us; we pay shipping back to you.

Kits assembled by the purchaser are also have a one (1) year against component failure. Breakage or overheating damage from soldering of components during assembly is not covered under warranty.

Damage to the IRF730 or the STW20NK50Z transistors due to over voltage operation or inadequate cooling is not covered under warranty.

For all warranty claims or equipment service, please contact us by email or telephone before returning equipment for service.

Out-of-Warranty repair service is at the rate of \$20/hour, with a maximum charge of \$50 per item, unless otherwise specified. Please contact us for additional pricing on custom repair services.

Contact us

Ralph Hartwell

Spectrotek Services

641 Sisson Road
Natchitoches, LA
71457-6743
USA

318-527-6766

ralph@spectrotek.com

<http://rife-beam-ray.com>

<http://rifebeamray.com>

<http://w5jgv.com/rife>

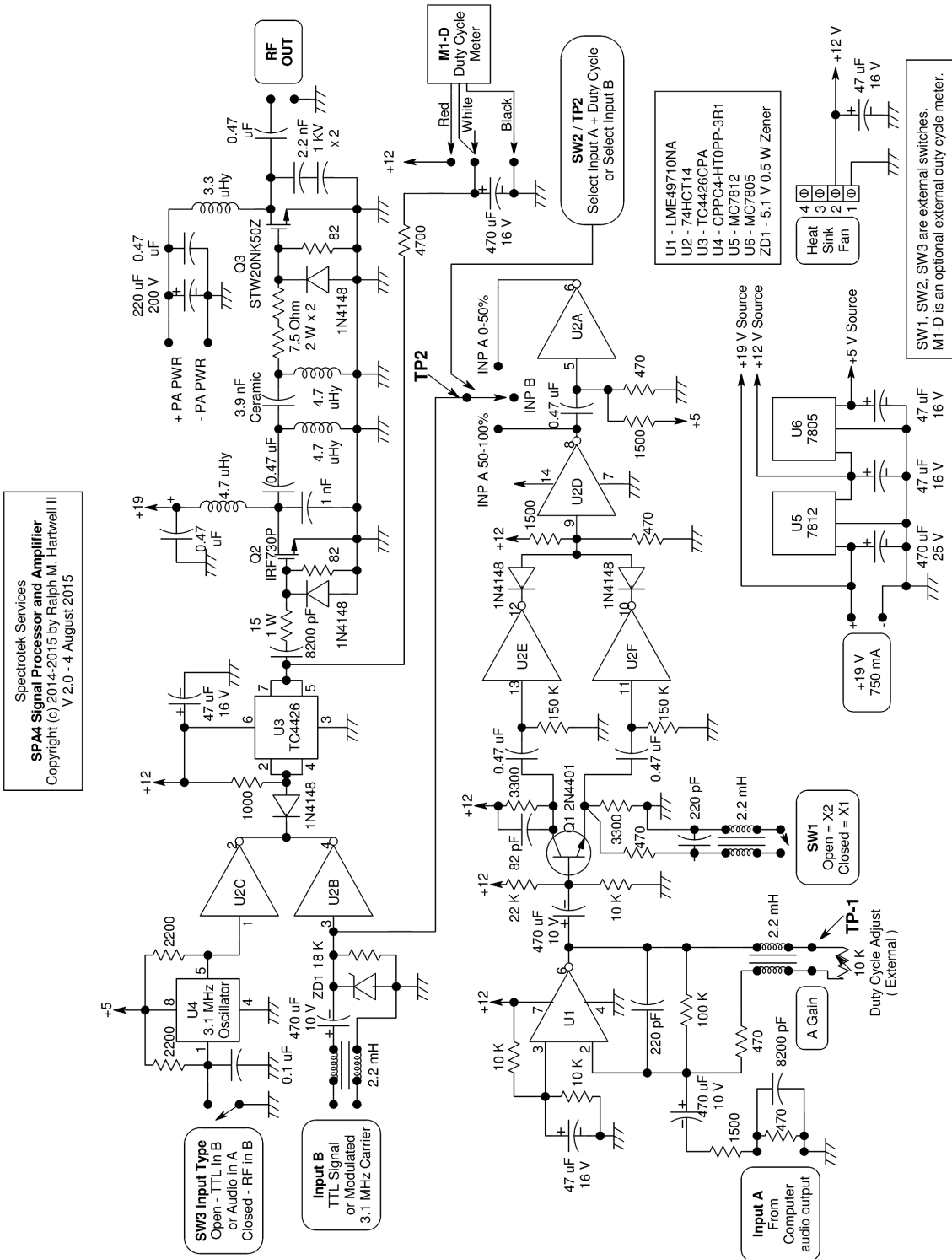

Figure 3
Schematic Diagram of the SPA4.

SPA4 Output Waveforms

To obtain the following waveforms, the SPA4 was connected to a 50 ohm dummy load.

The SPA4 was driven by a UDB1108S signal generator set to the square wave mode.

The output power level of the SPA4 was 200 watts peak RF power to the dummy load.

The upper (red) trace is the output of the SPA4, and the lower (yellow) trace is the input signal from the UDB1108S signal generator.

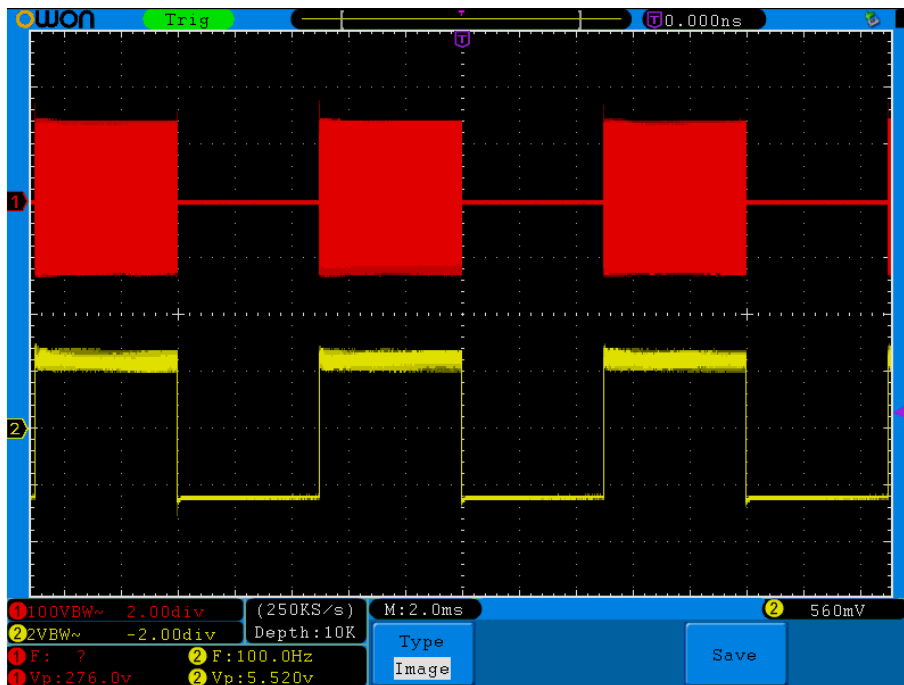

Figure 4 - 100 Hz, 50% duty cycle.

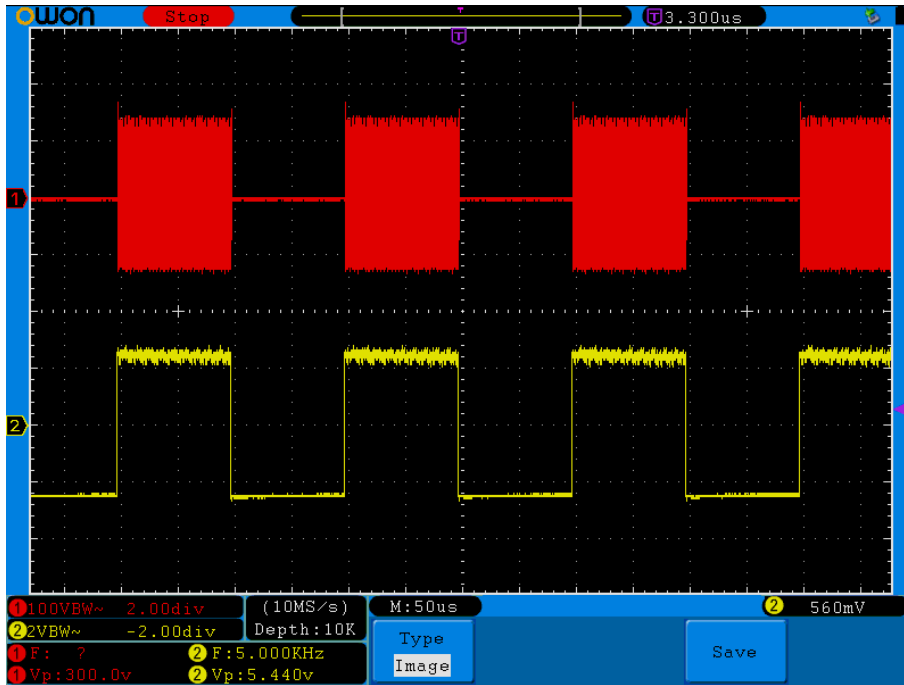

Figure 5 – 1,000 Hz, 50% duty cycle.

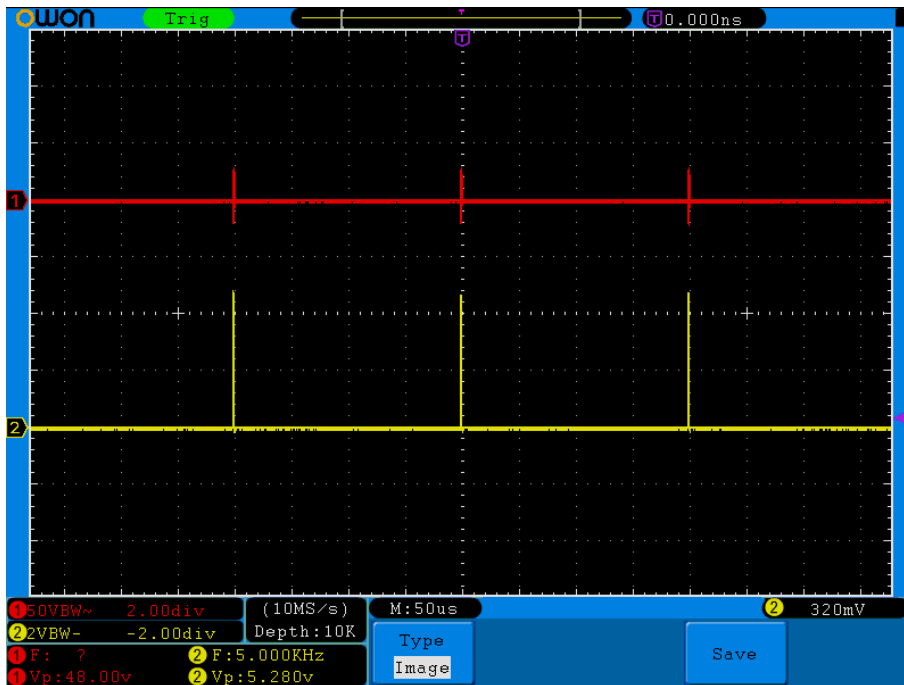

Figure 6 – 5,000 Hz, 1% duty cycle.

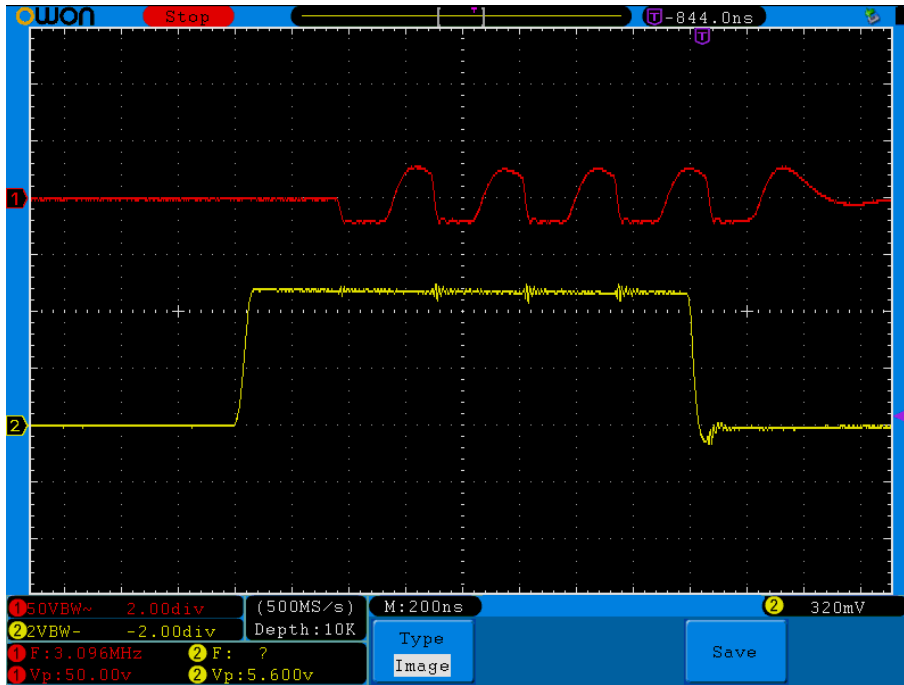

Figure 7 - 5,000 Hz, 1% duty cycle, expanded scale, showing individual RF cycles.

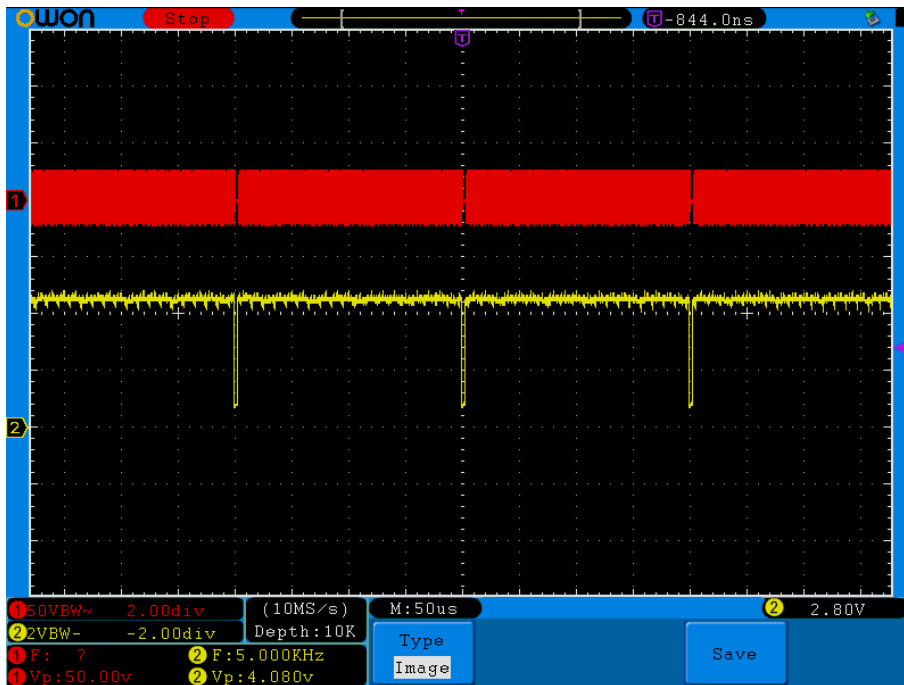

Figure 8 - 5,000 Hz, 99% duty cycle.

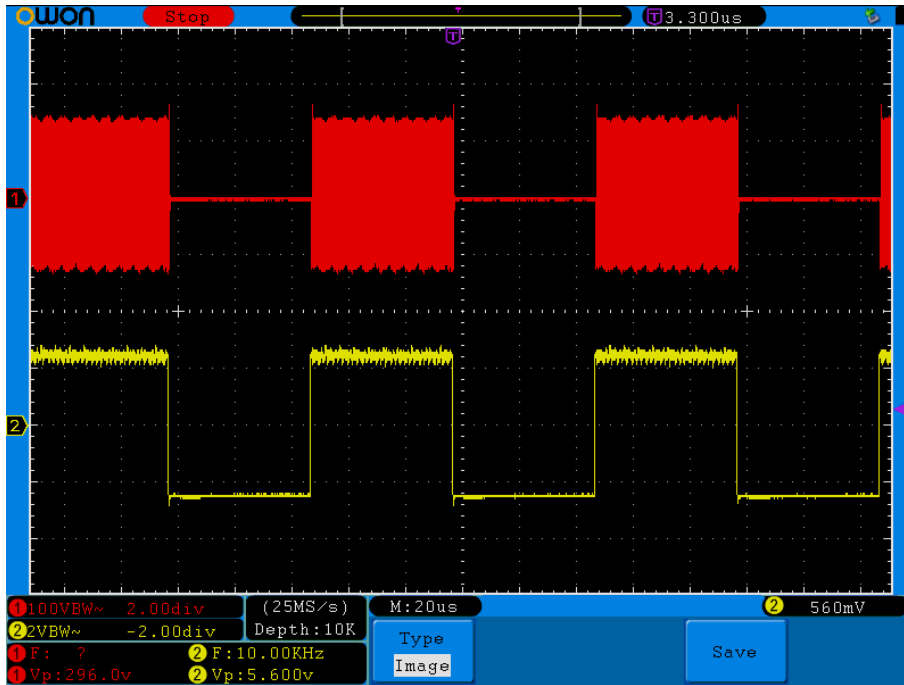

Figure 9 – 10,000 Hz, 50% duty cycle.

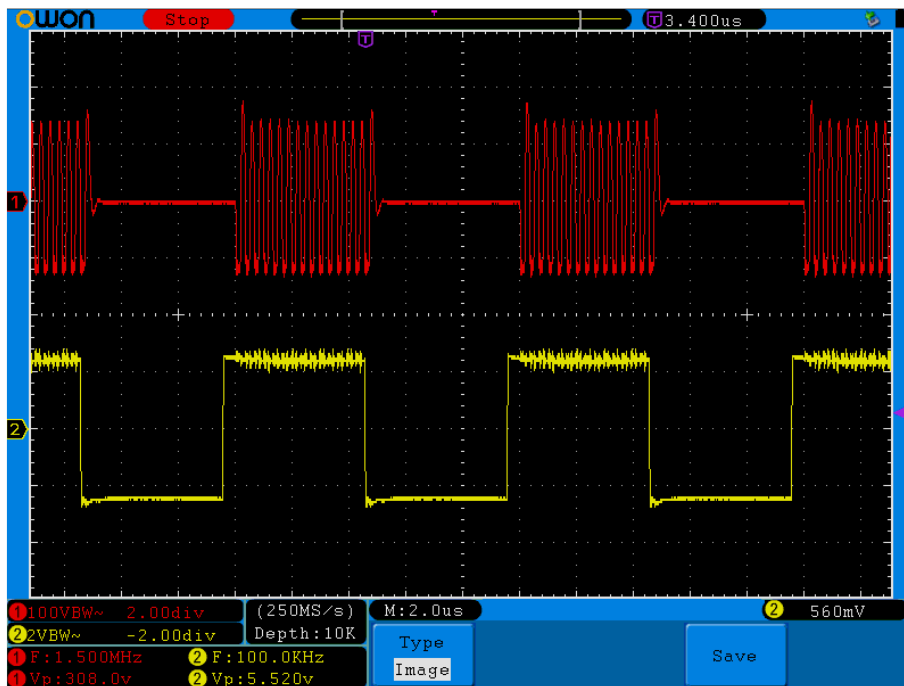

Figure 10 – 100,000 Hz, 50% duty cycle.

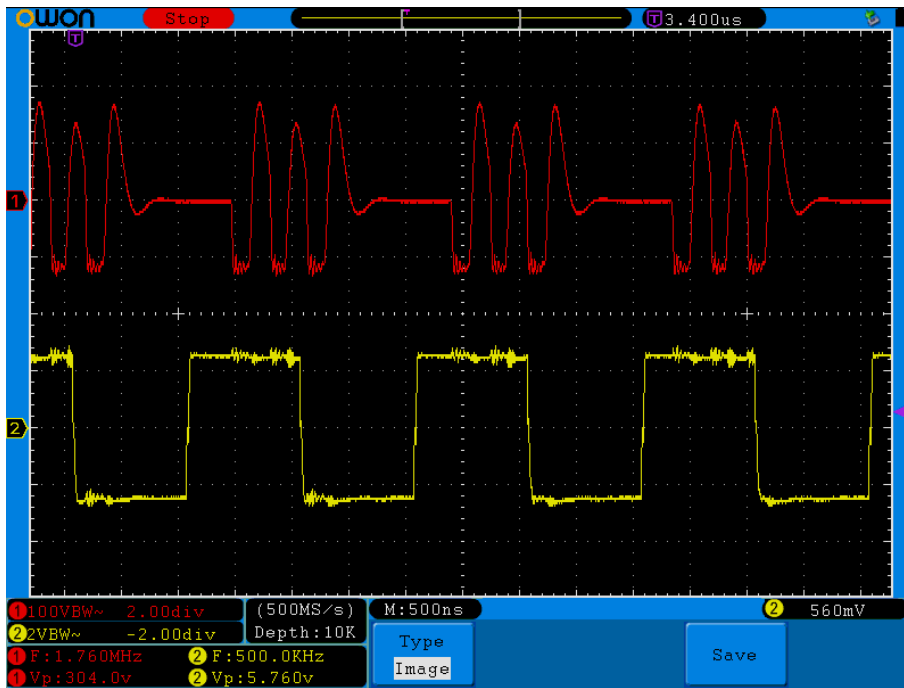

Figure 11 – 500,000 Hz, 50% duty cycle.

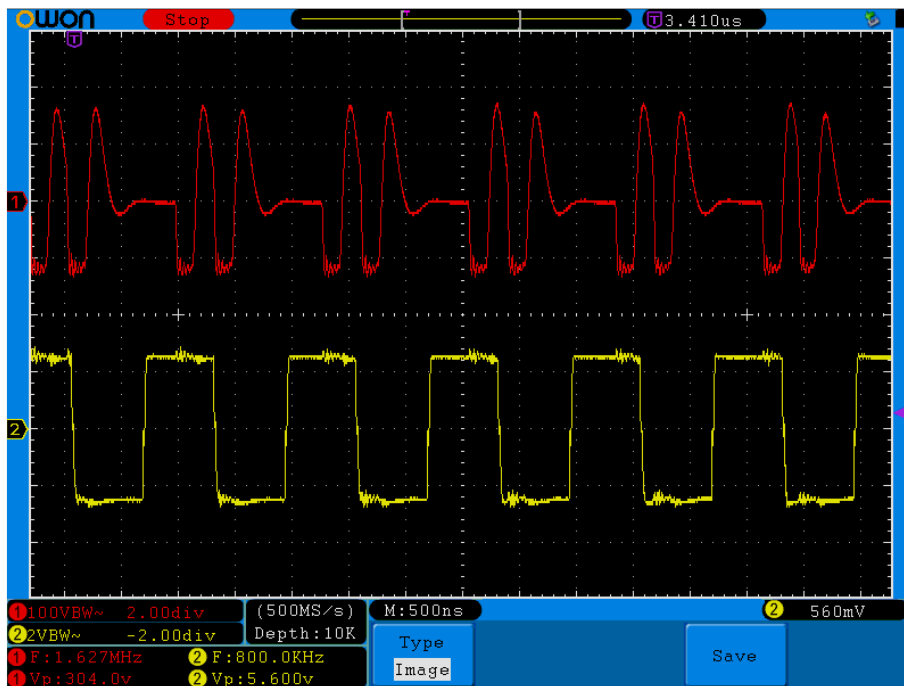

Figure 12 – 800,000 Hz, 50% duty cycle.

The following waveform photographs were obtained using a Tektronix type 466 oscilloscope that was adjusted to a 20 MHz bandwidth.

The connecting coaxial cable between the SPA4 and the 3.1 MHz link coil coupler, (which was connected to the plasma tube,) was a 20 foot / 6 meter length of RG-58/U coaxial cable.

The SPA4 was driven by a standard TTL output level frequency generator.

The output power level of the SPA4 was 300 watts peak, 150 watts average.

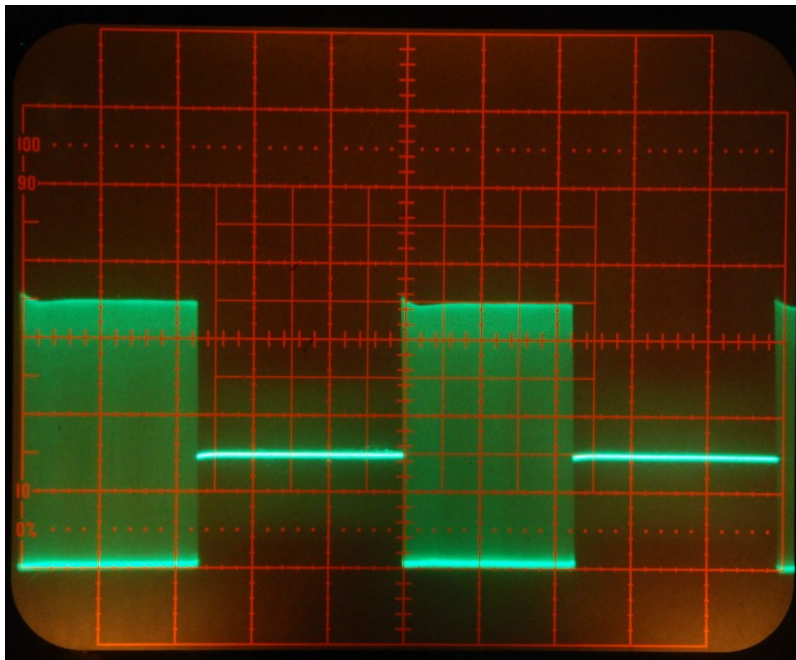

Figure 13

Output of the SPA4 connected to Chev 8" Phanotron Tube with a Modulating Frequency of 20 Hz at a 50% Duty Cycle.

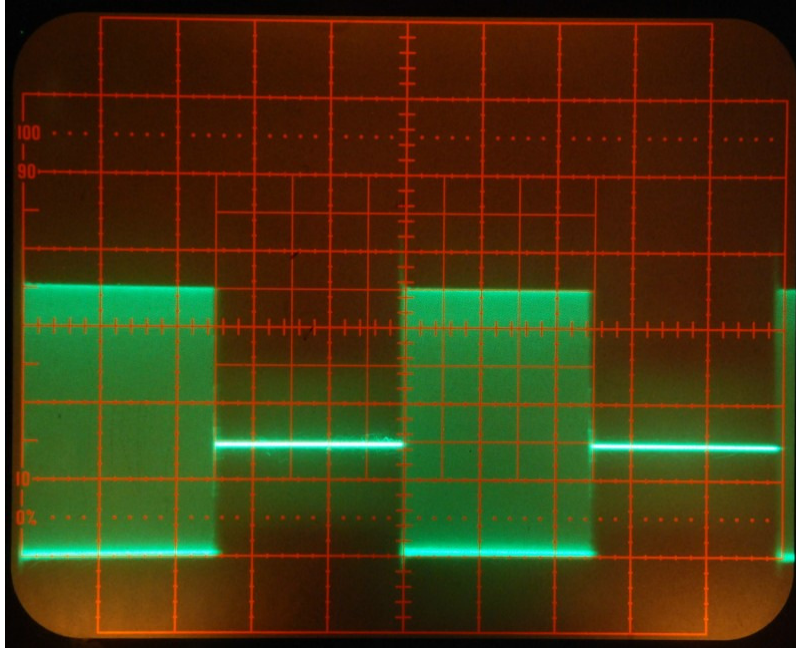

Figure 14

Output of the SPA4 connected to Chev 8" Phanotron Tube with a Modulating Frequency of 2000 Hz at a 50% Duty Cycle.



Figure 15

Output of the SPA4 connected to Chev 8" Phanotron Tube with a Modulating Frequency of 20 KHz at a 50% Duty Cycle.

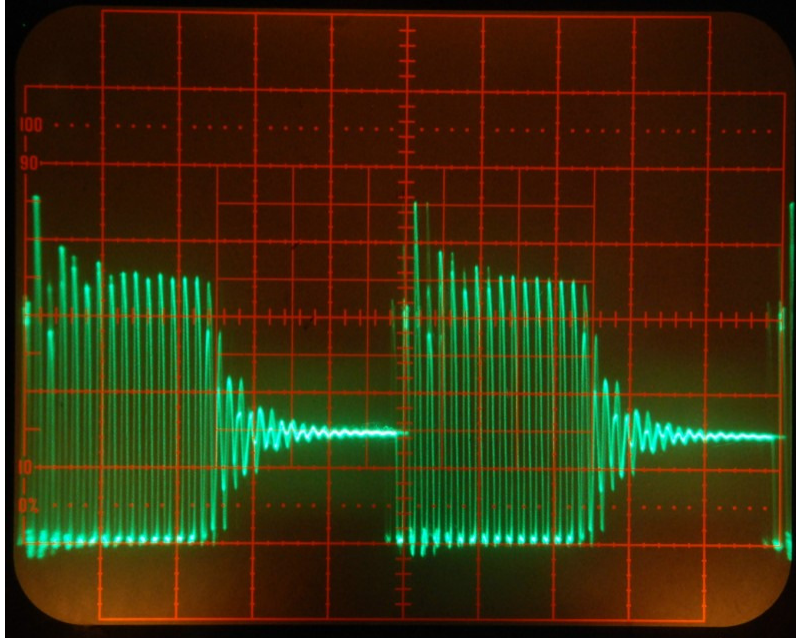

Figure 16

Output of the SPA4 connected to Chev 8" Phanotron Tube with a Modulating Frequency of 100 KHz at a 50% Duty Cycle.

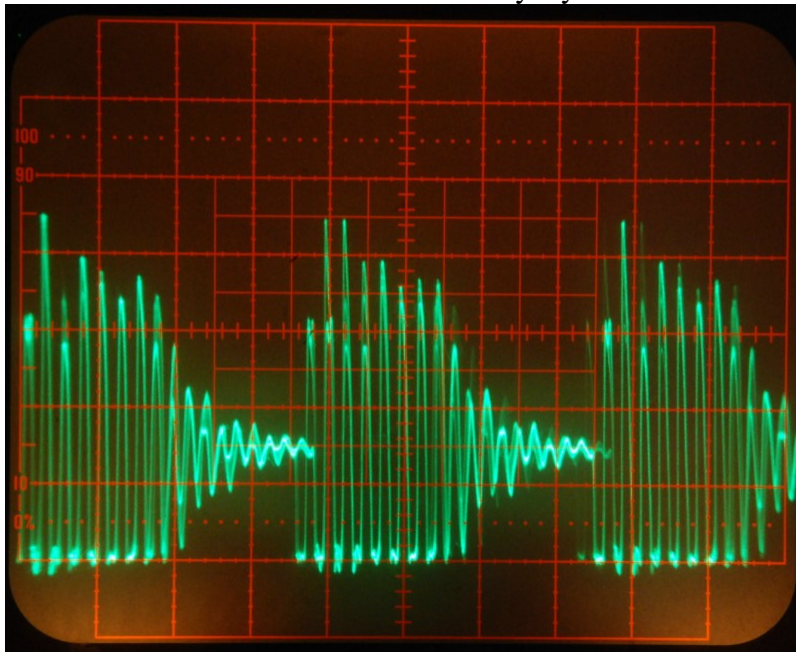

Figure 17

Output of the SPA4 connected to Chev 8" Phanotron Tube with a Modulating Frequency of 200 KHz at a 50% Duty Cycle.



Figure 18

Output of the SPA4 connected to Chev 8" Phantotron Tube with a Modulating Frequency of 400 KHz at a 50% Duty Cycle.



Edited by CAT