

Instruction Manual

For the

LC31L-ST Link Coupler

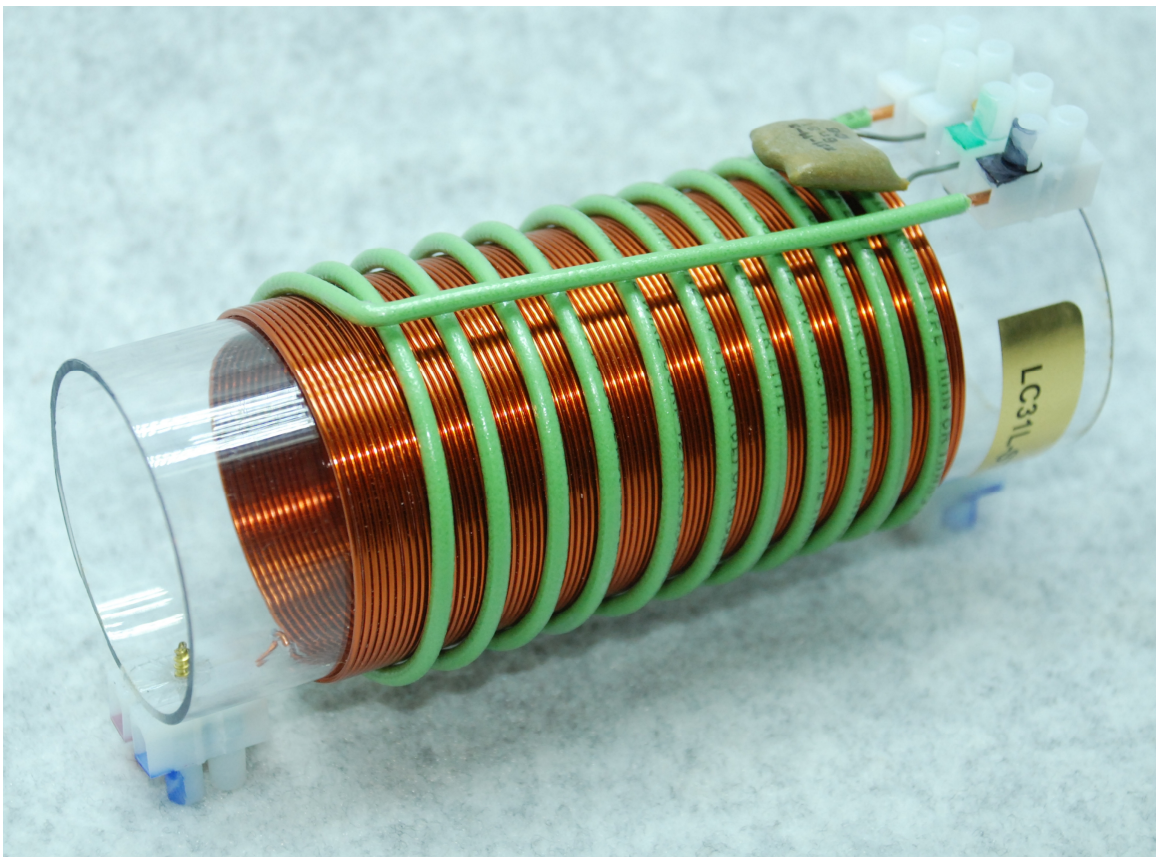

02 April 2018

© 2012 - 2018 by Ralph Hartwell
Spectrotek Services
All rights reserved

RADIO FREQUENCY WARNING NOTICE

- If the LC31L-ST is installed incorrectly or used improperly, it is capable of causing severe radio frequency interference. To prevent this from occurring, observed the following warnings:
- The LC31L-ST is to be used as a research device only, or as part of a complete system to drive a plasma tube.
- The LC31L-ST is not intended to be used for any form of radio transmission in any manner whatsoever.
- The LC31L-ST is not intended to be connected to an antenna or to any radiating element or to be used for any form of radio communications purposes in any manner whatsoever.
- All electrical connections to the input terminals of the LC31L-ST are to be made by the use of properly shielded 50-ohm coaxial cable capable of handling at least 500 watts at 3.1 MHz.
- All connections are to be made in such a manner as to minimize any RF radiation from the connecting wires to the LC31, particularly from the wires connecting to the plasma tube.
- The operating frequency range of the LC31L-ST should be restricted to a 1 MHz portion of the spectrum centered at 3.1 MHz.
- Avoid physical contact with the LC31L-ST during operation. Very high RF voltages are developed on the secondary coil during operation. Painful RF burns may result from accidental contact with exposed wires.

Index and Table of Contents

Radio Frequency Warning Notice	3
General Information	5
Connections to the LC31L-ST	5
Input Terminal Block Connection Options	6
Output Terminal Connection Block	7
Mounting the LC31	8
Cooling the LC31L-ST	8
Electrodes	9
Interference Prevention	9
Specifications	10
Warranty and Contact Information	11
Schematic Diagram of the LC31L-ST for the Chev SSQ-ST Plasma Tube	12

About the LC31L-ST

The LC31L-ST has been designed as a replacement for the standard LC31 coupler for use with the SSQ-ST plasma tube. Due to the high power requirements of the SSQ-ST, the original LC31 may overheat unless it is supplied with forced air cooled when it is operated at high power levels.

The new LC31L-ST has a heat resistant polycarbonate coil form with reconfigured coil windings. These changes allow the LC31L-ST to spread the heat that is produced during operation over the entire length of the coil. This results in greater power handling capacity for the LC31L-ST while allowing the unit to operate at a lower overall temperature.

What does the LC31L-ST do?

The LC31L-ST is designed to provide an effective means of transferring RF energy from a Spectrotek Services processor-amplifier to a Cheb SSQ-ST plasma tube. Due to the design of the LC31L-ST the fast rise and fall times of the square wave modulated RF signal from the amplifier are sent to the plasma tube. Commercial antenna tuners will often distort the envelope of the RF signal. The LC31L-ST avoids this distortion.

What type of amplifier may be used with the LC31?

The LC31L-ST coupler has been designed to be used with the Spectrotek Services PA1, PA2, PA3, SPA4 and SPA5 amplifiers.

Connections to the LC31L-ST

All connections to the LC31L-ST are made by using the eight screw terminals that are located in the three plastic terminal blocks that are mounted on the ends of the LC31L-ST coil assembly. These terminals will accept either solid or stranded conductor wire. Stranded wire is preferred for its flexibility when making connections between the LC31L-ST and the plasma tube.

A 4-position terminal block is used for the RF input. Two other two-position terminal blocks are located on opposite ends of the LC31L-ST. These terminal blocks are used for connecting the RF output from the LC31L-ST to the electrode wires of the SSQ-ST plasma tube.

When tightening the clamping screws in the terminal blocks, do not over tighten the screws to avoid damaging the connector. To connect the electrode wires, strip approximately 3/8 inch / 9 mm of insulation off the end of each electrode wire and insert the bare end of the wire into the hole in the terminal block. Gently, but firmly, tighten the clamping screw to fix the wire in place.

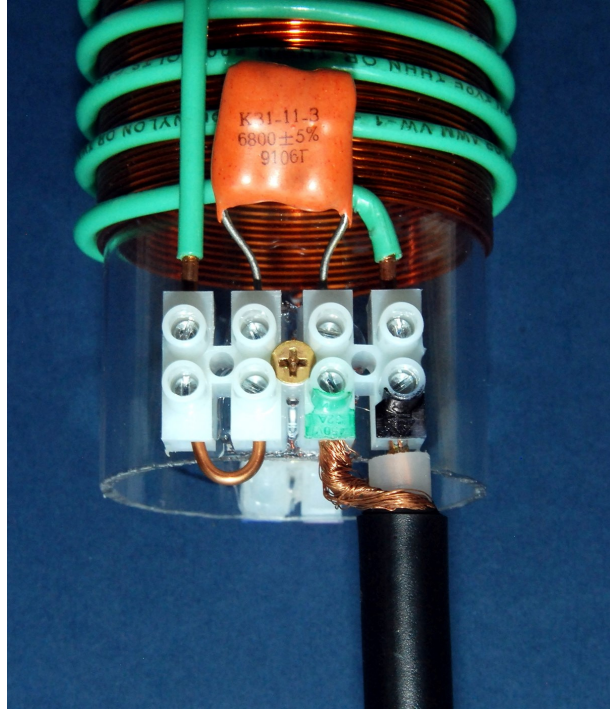

Figure 1

LC31L-ST RF Input Terminal Block

The LC31L-ST has been designed and optimized for use with a 23 foot / 7 meter length of 50-Ohm, solid dielectric insulation coaxial cable such as RG-213 (preferred) or RG-8. One end of the cable will be connected to the RF output terminals of the amplifier and the other end of this cable will be connected to the input connections of the LC31L-ST.

Caution: Type RG-58/U coaxial cable should not be used with the LC31L-ST because the high average power level required by the SSQ-ST plasma tube may cause overheating of the smaller RG-58/U cable.

Satisfactory performance will be obtained with cable lengths between 22 to 24 feet / 6.7 to 7.32 meters. Cable length should not deviate from these limits.

Because the cable is an active part of the matching system, changing either the type of cable or the length of the cable may result in improper operation or damage to the amplifier.

Note that coaxial cables with an impedance of 75 ohms should not be used as they will cause a severe impedance mismatch between the LC31L-ST and the amplifier, which may result in damage to the RF amplifier.

When connecting the coaxial cable to the LC31L-ST, the center wire of the coaxial cable should be connected to the BLACK terminal block. The shield braid of the coaxial cable should be connected to the GREEN terminal block as seen in Figure 1.

In order to allow free air flow around the wires for cooling, the primary winding is not secured with adhesive. This means that the turns may shift slightly during shipment. Before installing your LC31L-ST please ensure that the turns of the primary winding are spaced away from each other as shown in Figure 2.

Note that there is a small copper wire "U" shaped jumper that is connected between the two WHITE terminal blocks. This jumper must be installed or the LC31L-ST will not work properly. Damage to the amplifier may result if operation is attempted with this jumper removed.

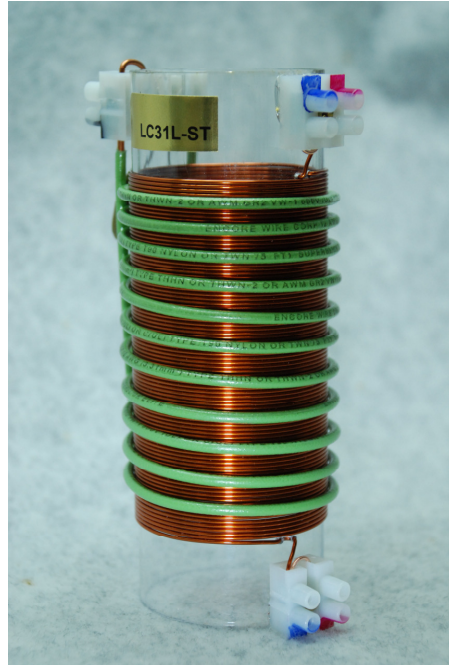

Figure 2

LC31L-ST RF Output Terminal Block

There is a 2-position terminal block mounted on each end of the LC31L-ST coil assembly. These output terminal blocks are used for connecting the electrode wires of the SSQ-ST plasma tube to the LC31L-ST.

Some versions of the LC31L-ST couplers may have the electrode wire terminal blocks color coded RED and BLUE, or left uncolored (WHITE.) Regardless of color, both connections of each output terminal block (white-white or red-blue) are electrically connected together. This means that either terminal connection on an output terminal block may be used when connecting the electrode wire to the LC31L-ST.

A pair of insulated, flexible wires should be connected between the terminal blocks and the electrodes of the plasma tube. Each electrode wires should be 12 inches / 30.5 cm in length for use with the SSQ-ST. Use of wires of shorter or longer lengths will result in significant detuning of the LC31L-ST. This detuning will result in reduced power transfer to the plasma tube and possible damage to the amplifier.

Mounting the LC31

If possible, the LC31L-ST should be mounted in a horizontal position. Horizontal mounting allows for the most cooling air to flow around the coil of the LC31L-ST.

The LC31L-ST will become quite warm during operation. This is normal. The temperature rise will depend upon the level of RF power the LC31L-ST must process. Nothing should be allowed to interfere with the flow of cooling air to the LC31L-ST during operation.

The temperature of the LC31L-ST should not be allowed to exceed 120° C to prevent softening and deforming the Lexan coil form of the LC31L-ST.

The LC31L-ST should be kept at least 2 inches / 5 cm away from metal objects and wires. Wires or cables that are close to the LC31L-ST can easily pick up RF energy from the magnetic field surrounding the LC31L-ST. This induced signal may be radiated by the wires or cables, possibly causing RF interference to other devices.

Mounting the LC31L-ST to a wooden support is acceptable, but the LC31L-ST should not be placed directly against a wooden support to avoid blocking the flow of cooling air over the coils. Space the LC31L-ST about ½ inch / 13 mm away from the support structure to allow free air flow around the LC31L-ST. Nothing should pass through the center of the LC31L-ST as this will reduce air flow through the LC31L-ST.

When mounting the LC31L-ST assembly it is acceptable to drill one or more holes for mounting hardware in the exposed ends of the Lexan coil form of the LC31. These holes should be located at least ¾ inch / 38 mm away from the ends of the coil. Brass, iron, or stainless steel hardware may be used to mount the LC31L-ST.

Cooling the LC31L-ST

The temperature of the LC31L-ST should not be allowed to exceed 120° C to prevent softening and deforming the Lexan coil form of the LC31L-ST.

The use of a handheld infrared thermometer is suggested to monitor the temperature of the LC31L-ST.

Fan cooling of the LC31L-ST is usually not required. The coil temperature should be monitored with an infrared thermometer the first time the LC31L-ST is used at high power. When using amplifier DC supply voltages above 171 volts with a duty cycle of 50% or less, some cooling may be needed, depending on the ambient air temperature.

To avoid damage due to overheating, a fan should be used to blow air across the LC31L-ST during operation at power levels higher than 275 watts average power / 550 watts peak power with a 50% duty cycle. Note that with most plasma tube systems, an amplifier DC supply voltage of 171 volts will produce 240 watts average power or 480 watts peak power output

Electrodes

Spectrotek Services type E4 electrodes (no electrode wires) or E4W electrodes (with electrode wires attached) may be used, or you may fabricate your own electrodes.

Electrodes should be made from copper sheet, and be 2 inch / 50 mm in width. The electrodes should encircle the circumference of the plasma tube, except for a small gap where the ends of the electrodes come together for fastening. The electrodes should be coated on their outside surfaces with black, heat radiating paint which will withstand temperatures of up to 300° C. The inner surface of the electrodes that will be placed against the plasma tube should remain uncoated.

Preventing Interference to Other Devices

The most likely cause of electrical interference to other devices will be from stray RF radiation from the plasma tube and the wires connecting the plasma tube to the LC31L-ST. To minimize radiation from the coupler and the connecting wires, the wires should be of equal length. The wires should not be lengthened as this will increase the possibility of unwanted RF radiation.

In most jurisdictions, it is the responsibility of the operator of any radio frequency generating equipment to prevent the equipment for producing interference to other users of the radio frequency spectrum or other electronic equipment. Please be aware of local regulations before operating this equipment.

SPECIFICATIONS:

Input Load:

Designed to match the output of the PA1, PA2, PA3, SPA4 or SPA5 amplifiers.

Output Load:

Designed to match the Bill Chev SSQ-ST plasma tube when used with 2 inch wide electrodes and Side Wires.

Power Handling:

Up to 300 watts average RF power with modulation duty cycles from 0 to 100%.

Up to 600 watts peak RF power with modulation duty cycles from 0 to 50%.

Fan cooling may be required above 200 watts average power depending on coil temperature, which should not exceed 120° C.

The power handling ability of the LC31L-ST is limited by the amount of heat it can dissipate during operation. Operation at very high power levels for extended periods of time with insufficient cooling may cause the LEXAN coil form to overheat and deform. **Such damage is not covered under warranty.**

Warranty

All our products carry a one (1) year warranty against manufacturing defects. Mechanical damage is not covered; i.e., you dropped it on the floor and then accidentally stepped on it. For warranty claims, you pay shipping to us; we pay shipping back to you.

Kits assembled by the purchaser are also have a one (1) year against component failure. Breakage or overheating damage from soldering of components during assembly is not covered under warranty.

For all warranty claims or equipment service, please contact us by email or telephone before returning equipment for service.

Out-of-Warranty repair service is at the rate of \$20/hour, with a maximum charge of \$50 per item, unless otherwise specified. Please contact us for additional pricing on custom repair services.

Contact us

Ralph Hartwell

Spectrotek Services

641 Sisson Road
Natchitoches, LA
71457-6743
USA

318-527-6766

ralph@spectrotek.com
<http://rifebeamray.com>
<http://w5jgv.com/rife>



Edited by CAT

RF Amplifier to Rife Tube Matching Network
 For Bill Cheb SSQ-ST Plasma Tube
 Copyright (c) 2016 by Ralph M. Hartwell II
 02 April 2018

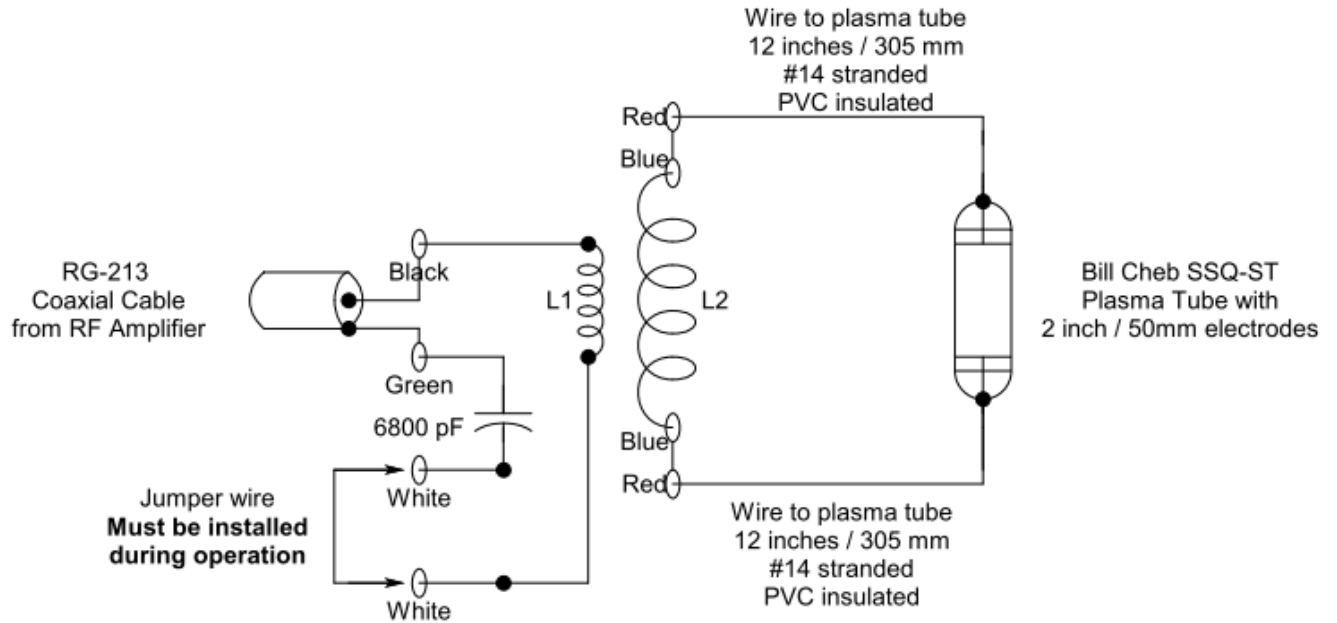

NOTES:

A 50 Ohm coaxial cable with a length of 23 feet / 7 meters is required between the amplifier and the LC31L-ST.

L1 -11 turns #12 THHN insulated copper wire space wound over the center of L2.

L2 - 86 turns #18 enameled copper wire close wound on a 2 inch / 50mm diameter Lexan tube.

Figure 3

Schematic Diagram of the LC31L-ST for use with the Cheb SSQ-ST Plasma Tube.