

Parallel Operation of three PA1 RF Power Amplifiers

When Driven by a Single SSQ-2F v3.10 or later version.

For 3.1 or 3.3 MHz Carrier Operation only.

Copyright (c) 2013 by Ralph M. Hartwell II

All Rights Reserved

4 August 2013

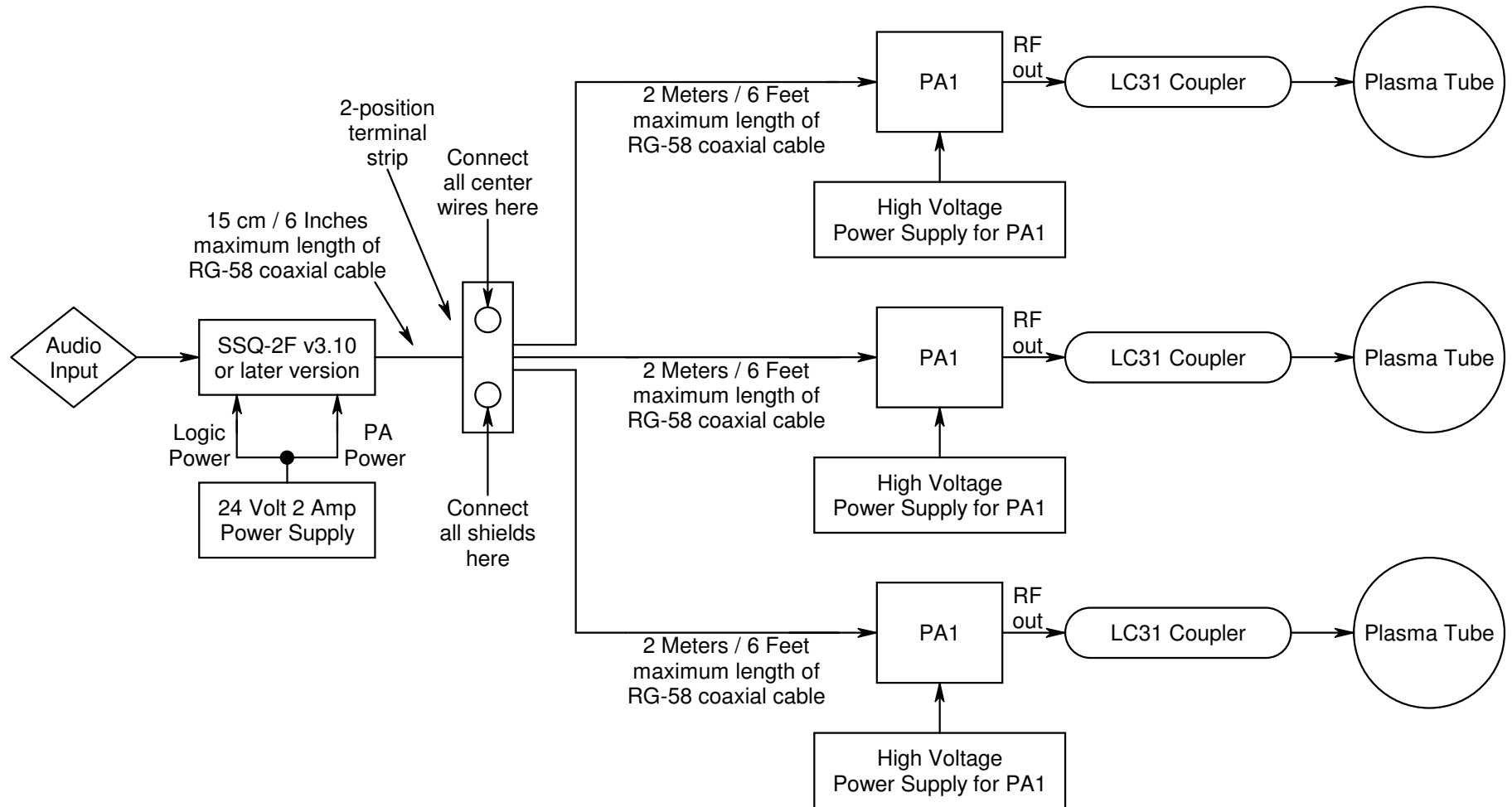

- RG-58 coax cable is suggested, but any small diameter coaxial cable may be used.
- The coaxial cables from the SSQ-2F to the PA1 amplifiers should be the same length.
- The PA1 amplifiers may be driving different types of plasma tubes and may be using different power supply voltages.
- The 12 volt regulator and the IRF730 on the SSQ-2F must be properly heat sunk.
- The DC supply voltage to the SSQ-2F should be 24 volts.
- Any of the PA1 amplifiers may be turned off during operation without affecting the operation of the other amplifiers.