

**RF Amplifier to Rife Tube Matching Network**  
 Copyright (c) 2012 by Ralph M. Hartwell II  
 V1.01 19 July 2012

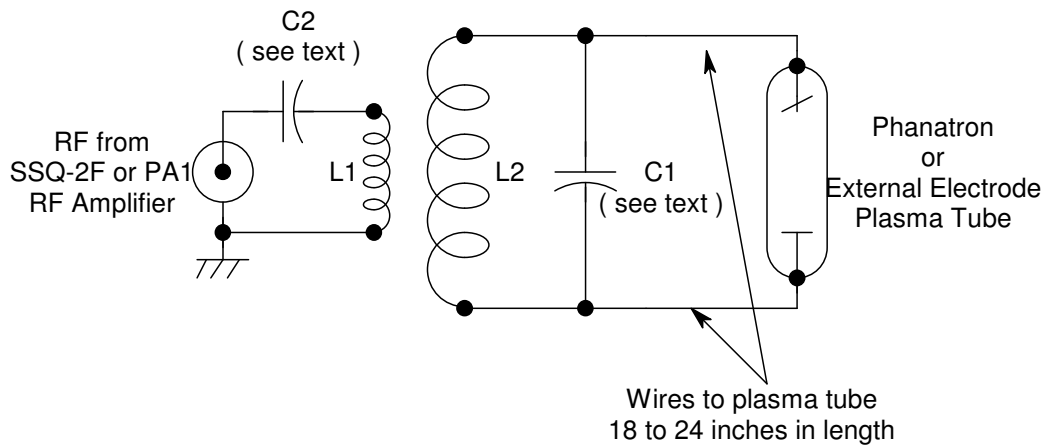

NOTE: The values specified here are for use with a 50 Ohm coaxial cable with a length of 24 feet / 7.35 meters between the RF source and the matching network. Using a different length of coaxial cable will require adjustment to the value of C2.

C1 - between 15 to 35 pF. This capacitor is made from a length of RG213 coaxial cable.

C1 - 6" active length, made from a 7" length of cable when used with a Cheb 1" x 14" SSQ-PT external electrode tube..

C1 - 7" active length, made from an 8" length of cable when used with a Cheb 8" Phanatron tube.

C2 - 2200 pF Mica 500 Volts when the coupler is used with a Cheb 8" Phanatron tube.

C2 - 1100 pF Mica 500 Volts when used with a Cheb 1" x 14" SSQ-PT external electrode tube.

L1 - 11 turns #14 THHN copper wire close wound over the center of L2.

L2 - 94 turns # 18 enameled copper wire close wound on a 6" long x 2" diameter length of PVC pipe.

Coil form is a 7" length of 1-1/2" Schedule 40 PVC pipe.