

SWITCHMODE™ Power Supply Reference Manual



ON Semiconductor



SWITCHMODE™ Power Supplies

Reference Manual and Design Guide

SMPSRM/D
Rev. 2, Apr-2000

© SCILLC, 2000
Previous Edition © 1999
“All Rights Reserved”



ON Semiconductor

SMPSRM

ON Semiconductor and  are trademarks of Semiconductor Components Industries, LLC (SCILLC). SCILLC reserves the right to make changes without further notice to any products herein. SCILLC makes no warranty, representation or guarantee regarding the suitability of its products for any particular purpose, nor does SCILLC assume any liability arising out of the application or use of any product or circuit, and specifically disclaims any and all liability, including without limitation special, consequential or incidental damages. "Typical" parameters which may be provided in SCILLC data sheets and/or specifications can and do vary in different applications and actual performance may vary over time. All operating parameters, including "Typicals" must be validated for each customer application by customer's technical experts. SCILLC does not convey any license under its patent rights nor the rights of others. SCILLC products are not designed, intended, or authorized for use as components in systems intended for surgical implant into the body, or other applications intended to support or sustain life, or for any other application in which the failure of the SCILLC product could create a situation where personal injury or death may occur. Should Buyer purchase or use SCILLC products for any such unintended or unauthorized application, Buyer shall indemnify and hold SCILLC and its officers, employees, subsidiaries, affiliates, and distributors harmless against all claims, costs, damages, and expenses, and reasonable attorney fees arising out of, directly or indirectly, any claim of personal injury or death associated with such unintended or unauthorized use, even if such claim alleges that SCILLC was negligent regarding the design or manufacture of the part. SCILLC is an Equal Opportunity/Affirmative Action Employer.

PUBLICATION ORDERING INFORMATION

NORTH AMERICA Literature Fulfillment:

Literature Distribution Center for ON Semiconductor
P.O. Box 5163, Denver, Colorado 80217 USA
Phone: 303-675-2175 or 800-344-3860 Toll Free USA/Canada
Fax: 303-675-2176 or 800-344-3867 Toll Free USA/Canada
Email: ONlit@hibbertco.com
Fax Response Line: 303-675-2167 or 800-344-3810 Toll Free USA/Canada

N. American Technical Support: 800-282-9855 Toll Free USA/Canada

EUROPE: LDC for ON Semiconductor – European Support

German Phone: (+1) 303-308-7140 (M-F 1:00pm to 5:00pm Munich Time)
Email: ONlit-german@hibbertco.com
French Phone: (+1) 303-308-7141 (M-F 1:00pm to 5:00pm Toulouse Time)
Email: ONlit-french@hibbertco.com
English Phone: (+1) 303-308-7142 (M-F 12:00pm to 5:00pm UK Time)
Email: ONlit@hibbertco.com

EUROPEAN TOLL-FREE ACCESS*: 00-800-4422-3781

*Available from Germany, France, Italy, England, Ireland

CENTRAL/SOUTH AMERICA:

Spanish Phone: 303-308-7143 (Mon-Fri 8:00am to 5:00pm MST)
Email: ONlit-spanish@hibbertco.com

ASIA/PACIFIC: LDC for ON Semiconductor – Asia Support

Phone: 303-675-2121 (Tue-Fri 9:00am to 1:00pm, Hong Kong Time)
Toll Free from Hong Kong & Singapore:
001-800-4422-3781
Email: ONlit-asia@hibbertco.com

JAPAN: ON Semiconductor, Japan Customer Focus Center

4-32-1 Nishi-Gotanda, Shinagawa-ku, Tokyo, Japan 141-8549
Phone: 81-3-5740-2745
Email: r14525@onsemi.com

ON Semiconductor Website: <http://onsemi.com>

For additional information, please contact your local Sales Representative.

Forward

Every new electronic product, except those that are battery powered, requires converting off-line 115 Vac or 230 Vac power to some dc voltage for powering the electronics. The availability of design and application information and highly integrated semiconductor control ICs for switching power supplies allows the designer to complete this portion of the system design quickly and easily. Whether you are an experienced power supply designer, designing your first switching power supply or responsible for a make or buy decision for power supplies, the variety of information in the *SWITCHMODE™ Power Supplies Reference Manual and Design Guide* should prove useful.

ON Semiconductor has been a key supplier of semiconductor products for switching power supplies since we introduced bipolar power transistors and rectifiers designed specifically for switching power supplies in the mid-70's. We identified these as SWITCHMODE™ products. A switching power supply designed using ON Semiconductor components can rightfully be called a SWITCHMODE power supply or SMPS.

This brochure contains useful background information on switching power supplies for those who want to have more meaningful discussions and are not necessarily experts on power supplies. It also provides real SMPS examples, and identifies several application notes and additional design resources available from ON Semiconductor, as well as helpful books available from various publishers and useful web sites for those who are experts and want to increase their expertise. An extensive list and brief description of analog ICs, power transistors, rectifiers and other discrete components available from ON Semiconductor for designing a SMPS are also provided. This includes our newest GreenLine™, Easy Switcher and very high voltage ICs (VHVICs), as well as high efficiency HDTMOS® and HVTMOS® power FETs, and a wide choice of discrete products in surface mount packages.

For the latest updates and additional information on analog and discrete products for power supply and power management applications, please visit our website: (<http://onsemi.com>).

Table of Contents

	Page
“What Everyone Should Know About Switching Power Supplies” by Marty Brown	5
Introduction	5
Linear versus Switching Power Supplies	5
Basic Converters	5
Common Topologies	8
Power Factor Correction	13
Quasi-Resonant Converters	15
Losses and Stresses within Switching Power Supplies	17
Bipolar Power Transistors	18
Power MOSFETs	20
Rectifiers	21
Methods of Control	21
Optoisolated Voltage Feedback	23
First-Pass Selection of Semiconductors	24
Other Design Considerations	25
Transformers and Inductors	25
Cores	26
Snubbers and Clamps	27
The Printed Circuit Board Layout	28
Off-Line Power Supply Design and Safety Tips	28
SMPS Examples	29
Integrated Circuits for Switching Power Supply	30
Suggested Components for Specific Applications	31
Literature Available from ON Semiconductor	52
Application Notes, Brochures, Device Data Books and Device Models	52
References for Switching Power Supply Design	54
Books	54
Websites	55
Analog ICs for SWITCHMODE Power Supplies	57
Power Management Circuits	58
Systems Management Circuits	134
ON Semiconductor Worldwide Sales Offices	142
ON Semiconductor Standard Document Type Definitions	143

What Everyone Should Know About Switching Power Supplies

By: Marty Brown

Introduction

Efficient conversion of electrical power is becoming a primary concern to companies and to society as a whole. Switching power supplies offer not only higher efficiencies but also offer greater flexibility to the designer. Recent advances in semiconductor, magnetic and passive technologies make the switching power supply an ever more popular choice in the power conversion arena today.

This Guide is designed to give the prospective designer an overview of all the issues involved in designing switchmode power supplies. It describes the basic operation of the more popular topologies of switching power supplies, their relevant parameters, provides circuit design tips, and information on how to select the most appropriate semiconductor and passive components. This Guide lists the ON Semiconductor components expressly built for use in switching power supplies.

Linear versus Switching Power Supplies

Historically, the linear regulator was the primary method of creating a regulated output voltage. It operates by reducing a higher input voltage down to the lower output voltage by linearly controlling the conductivity of a series pass power device in response to changes in its load. This results in a large voltage being placed across the pass unit with the load current flowing through it. This *headroom loss* ($V_{\text{drop}} \cdot I_{\text{load}}$) causes the linear regulator to only be 30 to 50 percent efficient. That means that for each watt delivered to the load, at least a watt has to be dissipated in heat. The cost of the heatsink actually makes the linear regulator uneconomical above 10 watts for small applications. Below that point, however, they are cost effective in step-down applications.

The switching regulator operates the power devices in the full-on and cutoff states. This then results in either large currents being passed through the power devices with a low “on” voltage or no current flowing with high voltage across the device. This results in a much lower power being dissipated within the supply. The average switching power supply exhibits efficiencies of between 70 to 90 percent, regardless of the input voltage.

Higher levels of integration have driven the cost of switching power supplies downward which makes it an attractive choice for output powers greater than 10 watts or where multiple outputs are desired.

Basic Converters

Forward-Mode Converter Fundamentals

The most elementary forward-mode converter is the *Buck or Step-down Converter* which can be seen in Figure 1. Its operation can be seen as having two distinct time periods which occur when the series power switch is on and off. When the power switch is on, the input voltage is connected to the input of the inductor. The output of the inductor is the output voltage, and the rectifier is back-biased. During this period, since there is a constant voltage source connected across the inductor, the inductor current begins to linearly ramp upward which is described by:

$$i_{L(\text{on})} = \frac{(V_{\text{in}} - V_{\text{out}}) t_{\text{on}}}{L}$$

During the “on” period, energy is being stored within the core material of the inductor in the form of flux. There is sufficient energy stored to carry the requirements of the load during the next off period.

The next period is the “off” period of the power switch. When the power switch turns off, the input voltage of the inductor flies below ground and is clamped at one diode drop below ground by the *catch diode*. Current now begins to flow through the catch diode thus maintaining the load current loop. This removes the stored energy from the inductor. The inductor current during this time is:

$$i_{L(\text{off})} = \frac{(V_{\text{out}} - V_{\text{D}}) t_{\text{off}}}{L}$$

This period ends when the power switch is once again turned on.

Regulation is accomplished by varying the on-to-off duty cycle of the power switch. The relationship which approximately describes its operation is:

$$V_{\text{out}} \approx \delta \cdot V_{\text{in}}$$

where δ is the duty cycle ($\delta = t_{\text{on}} / (t_{\text{on}} + t_{\text{off}})$)

Basic Converters (continued)

The buck converter is capable of kilowatts of output power, but suffers from one serious shortcoming which would occur if the power switch were to fail short-circuited, the input power source is connected directly to the load circuitry with usually produces

catastrophic results. To avoid this situation, a *crowbar* is placed across the output. A crowbar is a latching SCR which is fired when the output is sensed as entering an overvoltage condition. The buck converter should only be used for board-level regulation.

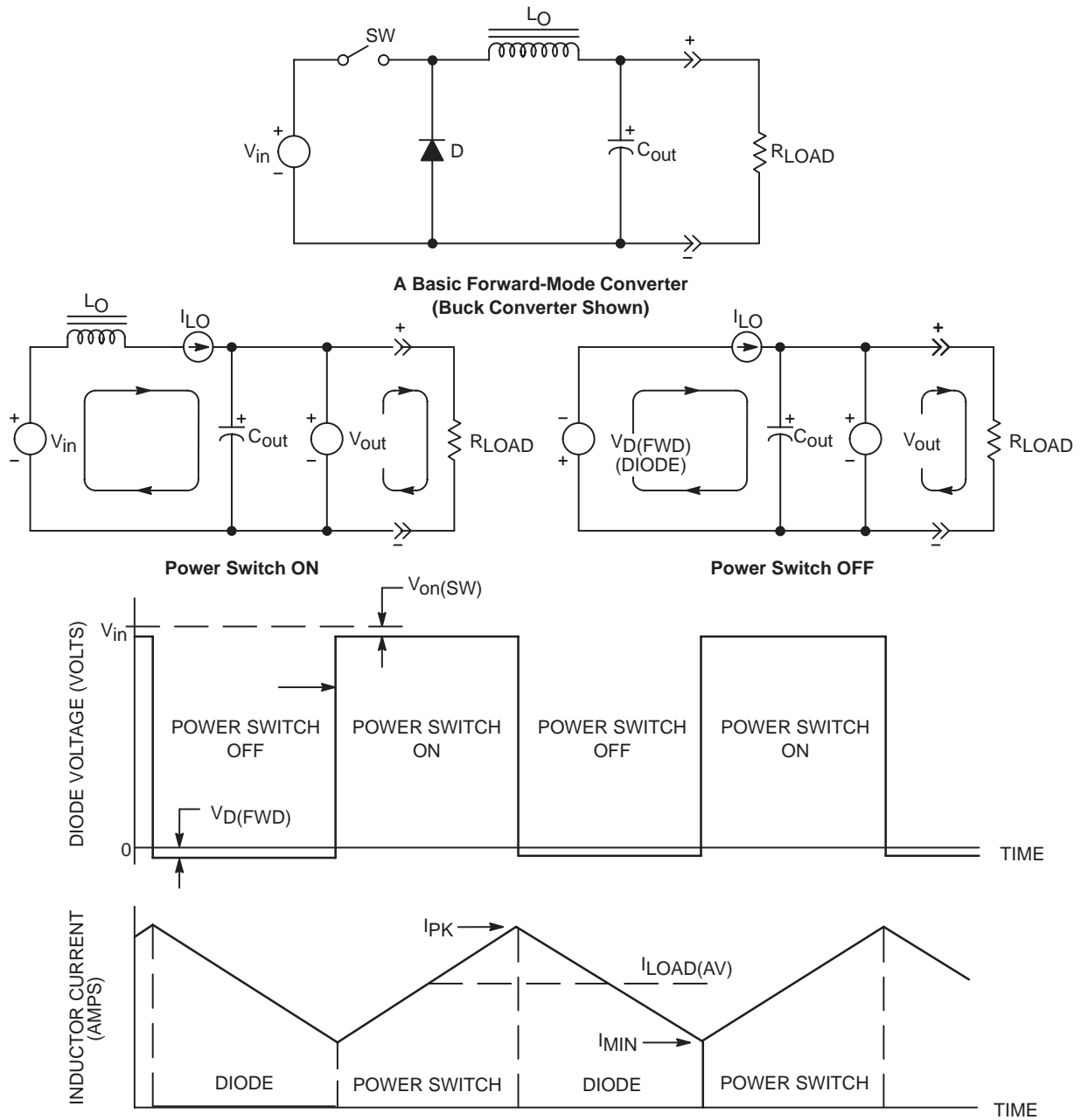

Figure 1. Forward-Mode Converter Operation (Buck Converter Shown)

Basic Converters (continued)

Flyback or Boost-mode Converter Fundamentals

The most elementary flyback-mode converter is the *Boost or Step-up Converter*. Its schematic can be seen in Figure 2. Its operation can also be broken into two distinct periods where the power switch is on and off. When the power switch turns on, the input voltage source is placed directly across the inductor. This causes the current to begin linearly ramping upwards from zero and is described by:

$$i_{L(on)} = \frac{(V_{in}) t_{on}}{L}$$

Once again, energy is being stored within the core material.

The amount of energy stored during each cycle times the frequency of operation must be higher than the power demands of the load or,

$$P_{sto} = 0.5 \cdot L \cdot I_{pk}^2 \cdot f_{op} > P_{out}$$

The power switch then turns off and the inductor voltage flies back above the input voltage and is clamped by the rectifier at the output voltage. The current then begins to linearly ramp downward until the energy within the core is completely depleted. Its waveform which is shown in Figure 3 is determined by:

$$i_{L(off)} = \frac{(V_{out} - V_{in}) t_{off}}{L}$$

The boost converter should also be only used for board-level regulation.

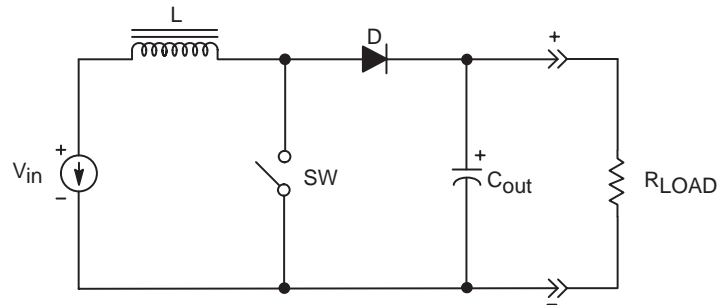

A Basic Flyback-Mode Converter (Boost Converter Shown)

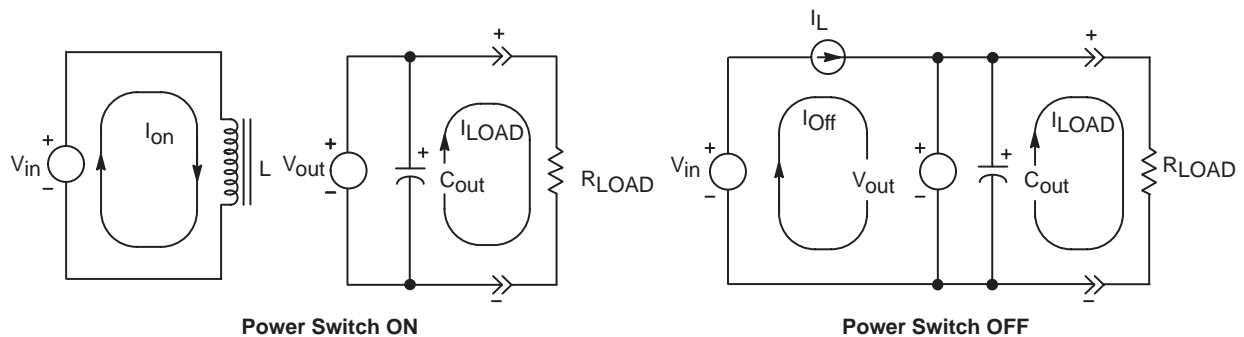

Figure 2. Schematic of a Boost Converter

SMPSRM

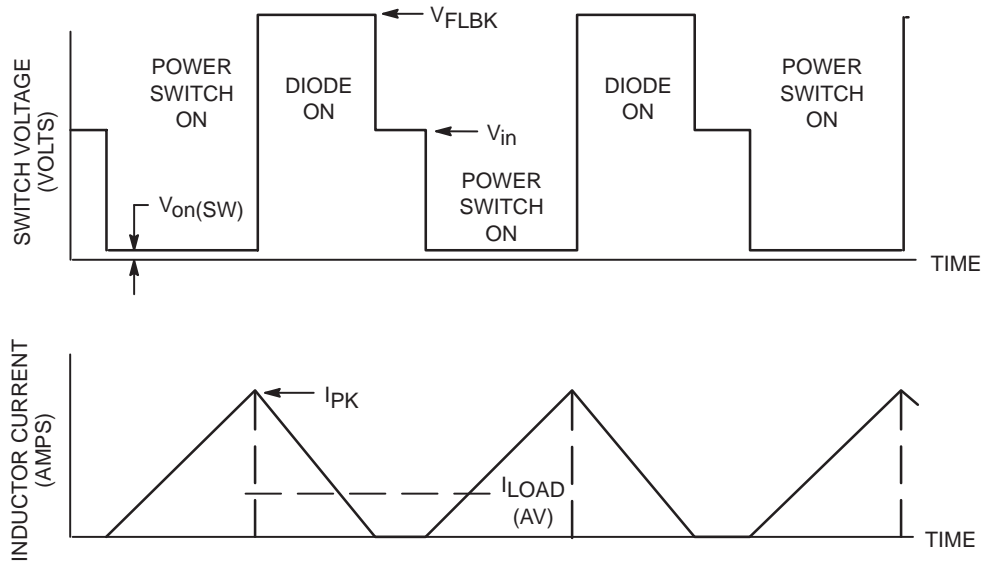

Figure 3. Waveforms for a Boost Converter

Common Topologies

A *topology* is the arrangement of the power devices and their magnetic elements. Each topology has its own merits within certain applications. Some of the factors which determine the suitability of a particular topology to a certain application are:

- 1) Is the topology electrically isolated from the input to the output or not.
- 2) How much of the input voltage is placed across the inductor or transformer.
- 3) What is the peak current flowing through the power semiconductors.
- 4) Are multiple outputs required.
- 5) How much voltage appears across the power semiconductors.

The first choice that faces the designer is whether to have input to output transformer isolation. Non-isolated switching power supplies are typically used for board-level regulation where a dielectric barrier is provided elsewhere within the system. Non-isolated topologies should also be used where the possibility of a failure does not connect the input power source to the

fragile load circuitry. Transformer isolation should be used in all other situations. Associated with that is the need for multiple output voltages. Transformers provide an easy method for adding additional output voltages to the switching power supply. The companies building their own power systems are leaning toward transformer isolation in as many power supplies as possible since it prevents a domino effect during failure conditions.

The remainder of the factors involve how much stress the power semiconductors are being subjected to. Table 1 shows the differences between the various topologies used within switching power supplies. Figure 4 illustrates where the transformer-isolated topologies are typically used within the power industry at various power and voltage levels. At reduced DC input voltages and at higher powers, the peak currents that must be sustained by the power switch grow higher which then affects the stress they must endure. The various areas show which topology best fits within that range of input voltage and output power that exhibits the least amount of stress on the power semiconductors.

Common Topologies (continued)

Table 1. Comparison of the PWM Switching Regulator Topologies

Topology	Pwr Range (Watts)	V _{in} (DC) Range	In/Out Isolation	Typical Effic. (%)	Relative Cost	Figure No.
Buck	0 – 1000	5.0 – 1000*	No	75	1.0	Figure 5
Boost	0 – 150	5.0 – 600*	No	78	1.0	Figure 6
Buck-Boost	0 – 150	5.0 – 600*	No	78	1.0	Figure 7
Half-Forward	0 – 250	5.0 – 500	Yes	75	1.4	Figure 8
Flyback	0 – 150	5.0 – 600	Yes	78	1.2	Figure 9
Push-Pull	100 – 1000	50 – 1000	Yes	72	2.0	Figure 10
Half-Bridge	100 – 500	50 – 1000	Yes	72	2.2	Figure 11
Full-Bridge	400 – 2000+	50 – 1000	Yes	69	2.5	Figure 12

* No human access – otherwise < 42.5 V and 8.0 Amp limit (UL, CSA, VDE)

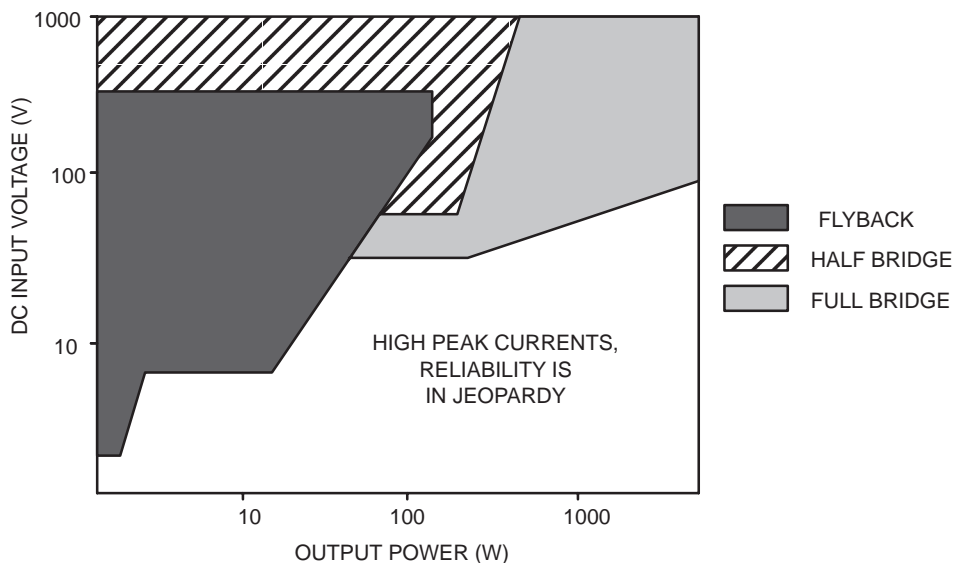

Figure 4. Where Various Transformer-Isolated Topologies are Commonly Used

SMPSRM

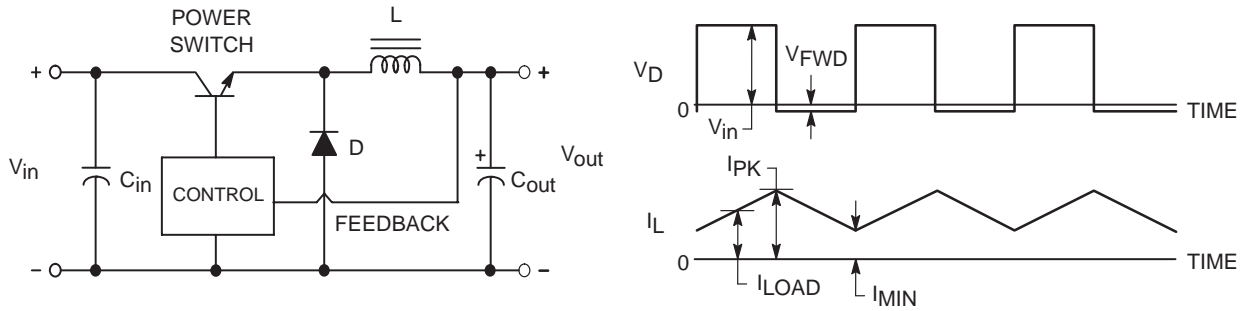

Figure 5. The Buck Regulator Topology

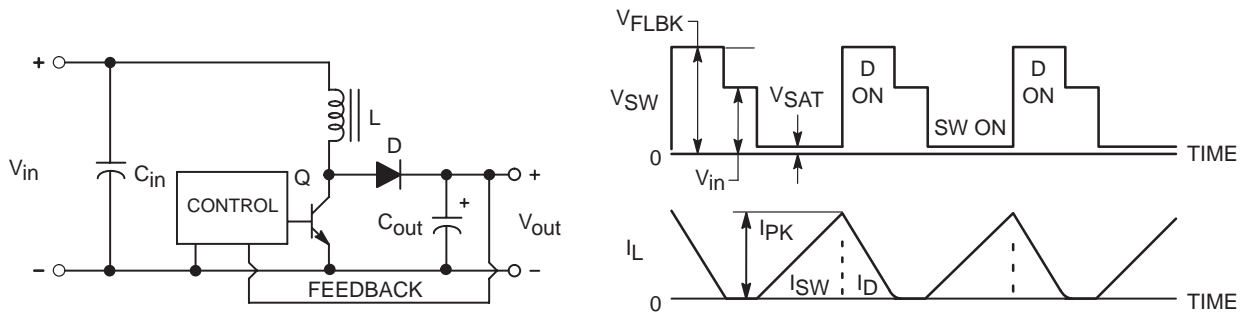

Figure 6. The Boost Regulator Topology

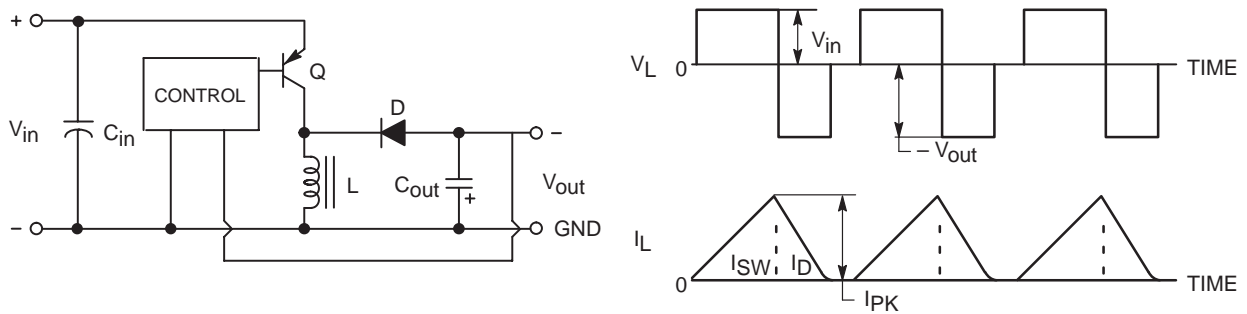

Figure 7. The Buck/Boost Regulator Topology

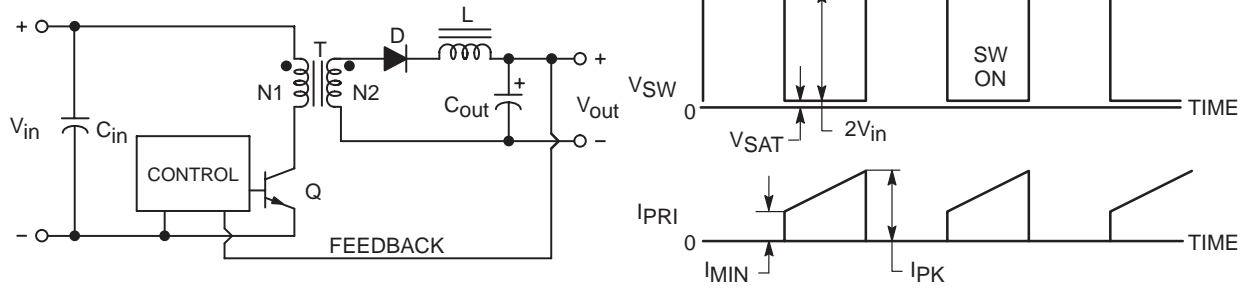

Figure 8. The Half-Forward Regulator Topology

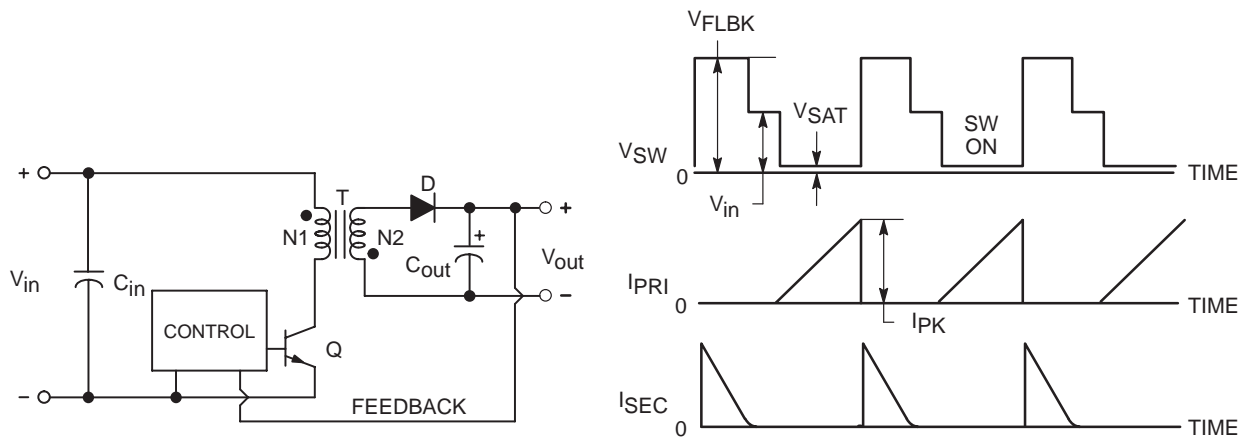

Figure 9. The Flyback Regulator Topology

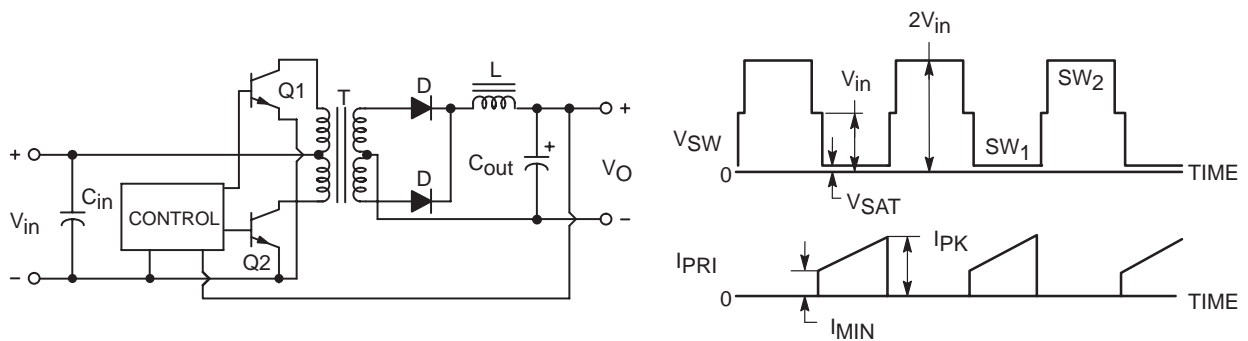

Figure 10. The Push-Pull Regulator Topology

SMPSRM

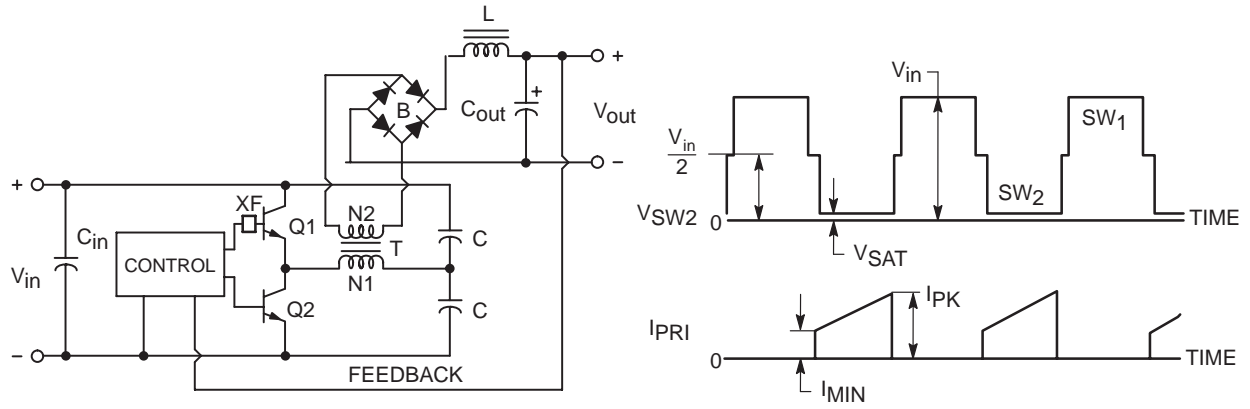

Figure 11. The Half-Bridge Regulator Topology

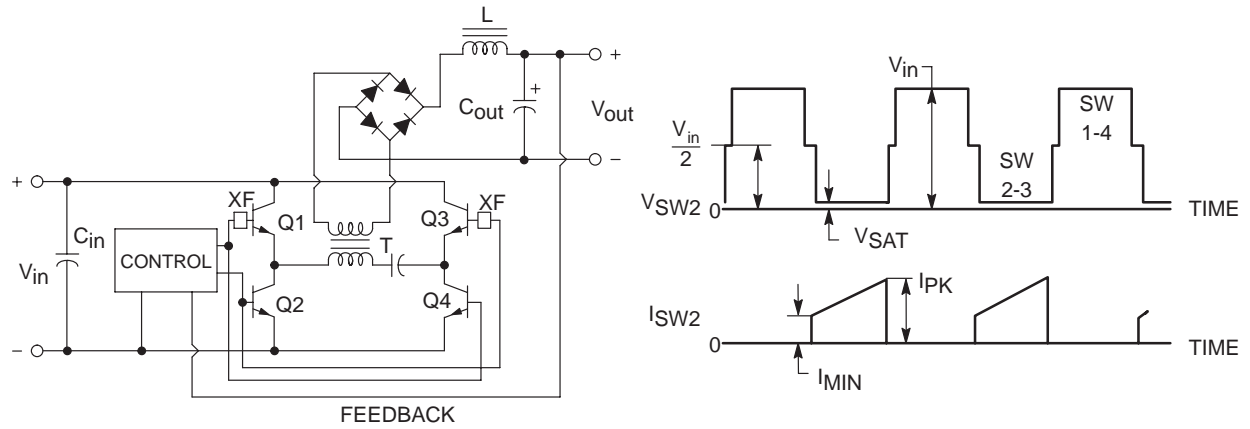

Figure 12. The Full-Bridge Regulator Topology

Power Factor Correction

The present day power supplies use a capacitive input filter when powered from the AC power line. A resulting shortcoming is that the AC line is rectified which results in high peak currents at the crests of the AC voltage as shown in Figure 13. These peak currents are typically three to five times higher than the average current drawn by the power supply. This causes excessive voltage drop in the wiring and imbalance problems in the three phase delivery system. Also the full energy potential of the AC line is not utilized.

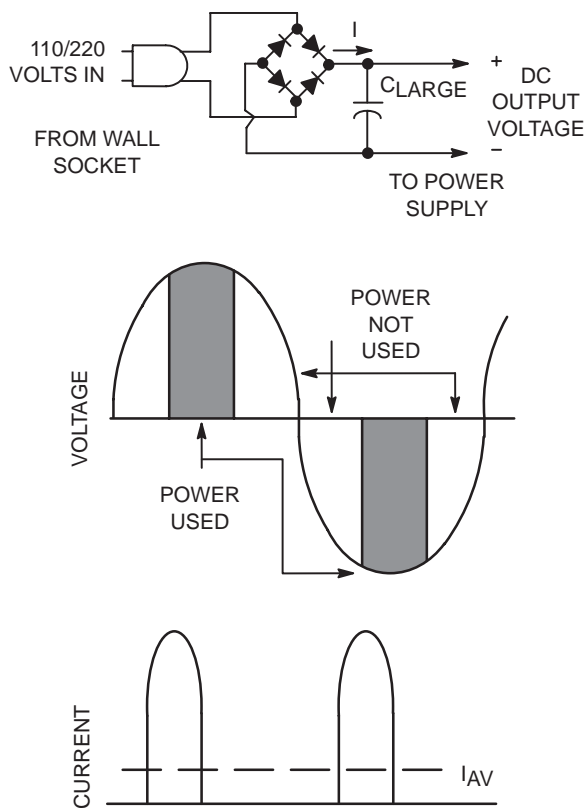

Figure 13. The Waveforms of a Capacitive Input Filter

The task is to increase the conduction angle of the AC rectifiers and to make the resulting current waveform look as sinusoidal and in phase with the voltage waveform as possible. In this way, the power drawn by the power supply from the line is maximized for real power as shown in Figure 14.

A popular method of accomplishing this is by using a boost converter prior to the actual power supply. Boost-mode supplies exhibit the largest input dynamic range of all the switching power supply topologies. Input

voltages down to 30 volts can be boosted to 370 volts on its output (higher than the highest expected peak operating AC crest voltage). The boost power factor correction circuit can be seen in Figure 36 on page 36. The bulk input filter capacitor is now placed on the output of the boost converter. The input capacitor, just following the 50/60 Hz rectifier bridge is now less than 1 uF. This produces an input voltage waveform to the PFC circuit that has a high level of ripple voltage and the boost converter draws its power directly from the line.

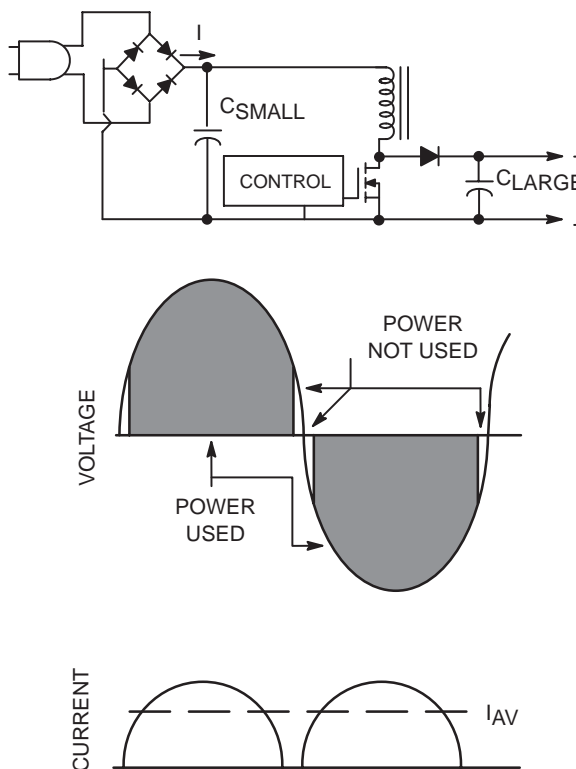

Figure 14. Power Factor Corrected Input

The semiconductors within a power factor correction stage have some special requirements. First, the 50/60 Hz rectifiers now have to be ultrafast rectifiers, since fast current pulses are being drawn through them. The boost output rectifier will have to be ultrafast if the boost converter is operating in the continuous-mode. The power switch has to clear the diode's reverse recovery charge. In the discontinuous-mode ($P_{in} < 200$ watts), the output rectifier need not be ultrafast since there is no current flowing through the diode prior to the power switch turning on.

SMPSRM

Power Factor Correction (continued)

Input current waveshaping is required by the regulatory agencies. The MC33262 has a internal multiplier to make the input current waveform mimic the input voltage waveform. All the circuitry needed to accomplish this task is included in the MC33262 with the

minimum of external components.

Figure 36 on page 36 is an 80 watt power factor correction stage for the 110 VAC line. This design meets all the specifications of IEC1000-3-2. The results are shown in Table 2.

Table 2. Power Factor Controller Test Data

V _{rms}	P _{in}	PF	I _{fund}	AC Line Input					DC Output				
				Current Harmonic Distortion (% I _{fund})					V _{O(pp)}	V _O	I _O	P _O	η(%)
THD	2	3	5	7									
90	85.9	0.999	0.93	2.6	0.08	1.6	0.84	0.95	4.0	230.7	0.350	80.8	94.0
100	85.3	0.999	0.85	2.3	0.13	1.0	1.2	0.73	4.0	230.7	0.350	80.8	94.7
110	85.1	0.998	0.77	2.2	0.10	0.58	1.5	0.59	4.0	230.7	0.350	80.8	94.9
120	84.7	0.998	0.71	3.0	0.09	0.73	1.9	0.58	4.1	230.7	0.350	80.8	95.3
130	84.4	0.997	0.65	3.9	0.12	1.7	2.2	0.61	4.1	230.7	0.350	80.8	95.7
138	84.1	0.996	0.62	4.6	0.16	2.4	2.3	0.60	4.1	230.7	0.350	80.8	96.0

T = Coilcraft N2881-A

Primary: 62 turns of # 22 AWG

Secondary: 5 turns of # 22 AWG

Core: Coilcraft PT2510, EE 25

Gap: 0.072" total for a primary inductance (L_p) of 320 μH

Heatsink = AAVID Engineering Inc. 590302B03600, or 593002B03400

Quasi-Resonant Converters

Quasi-resonant technology is a field within switching power supplies where the design goal is to eliminate the frequency dependent switching losses within the power switch and rectifiers. Eliminating the switching losses allows the designer to increase the operating frequency of the switching power supply with the goal of reducing size and weight. Acceptance of quasi-resonant technology has been slow because of some other issues presented by operating at high frequencies.

Schematically, quasi-resonant topologies are minor modifications of the PWM topologies. A resonant tank circuit has been added to the power switch section to

make either the current or the voltage “ring” through a half a sinusoid waveform. Since a sinusoid starts at zero and ends at zero, the product of the voltage and current at the starting and ending points is zero, thus has no switching loss.

There are two quasi-resonant methods: zero current switching (ZCS) or zero voltage switching (ZVS). ZCS is a fixed on-time, variable off-time method of control. ZCS starts from an initial condition where the power switch is off and there is no current flowing through the resonant inductor. The ZCS, quasi-resonant buck converter is shown in Figure 15.

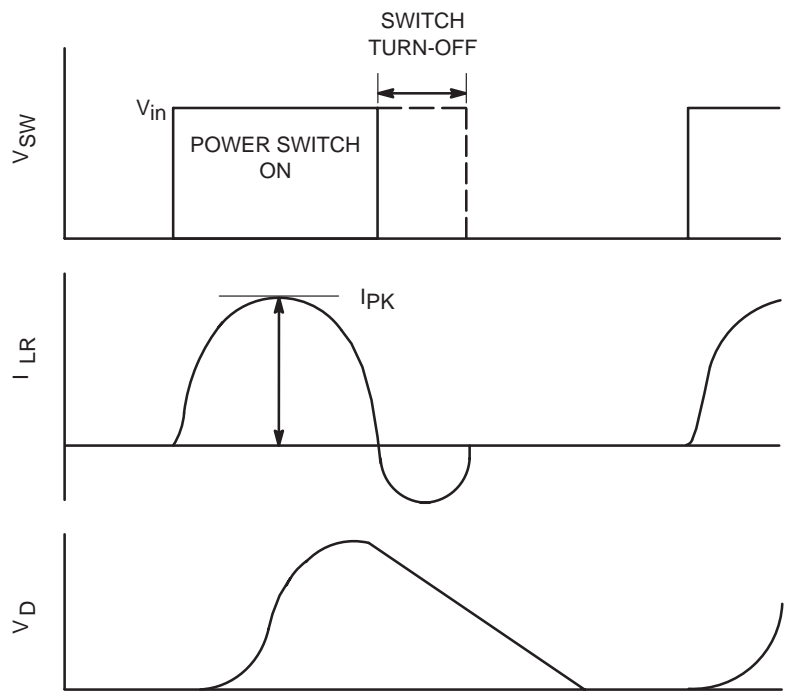
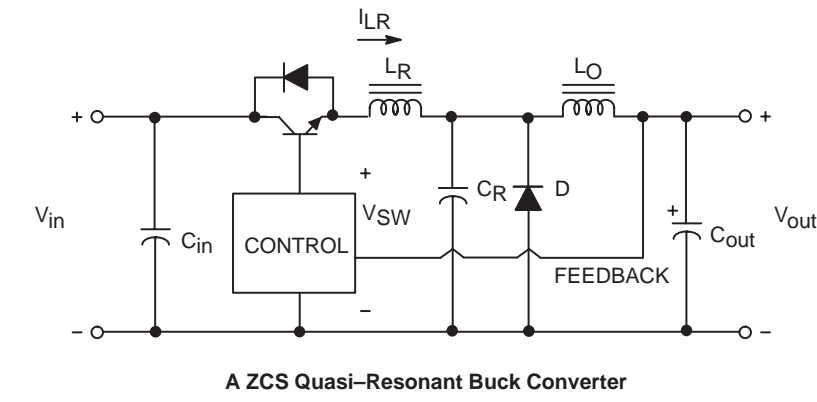

Figure 15. Schematic and Waveforms for a ZCS Quasi-Resonant Buck Converter

Quasi-Resonant Converters (continued)

In this design, both the power switch and the catch diode operate in a zero current switching mode. Power is passed to the output during the resonant periods. So to increase the power delivered to the load, the frequency would increase, and vice versa for decreasing loads. In typical designs the frequency can change 10:1 over the ZCS supply's operating range.

The ZVS is a fixed off-time, variable on-time method of control. Here the initial condition is when the power switch is on, and the familiar current ramp is flowing through the filter inductor. The ZVS, quasi-resonant

buck converter is shown in Figure 16. Here, to control the power delivered to the load, the amount of “resonant off times” are varied. For light loads, the frequency is high. When the load is heavy, the frequency drops. In a typical ZVS power supply, the frequency typically varies 4:1 over the entire operating range of the supply.

There are variations in the resonant field that promote zero switching losses such as full resonant PWM, full and half-bridge topologies for the higher powers and resonant transition topologies.

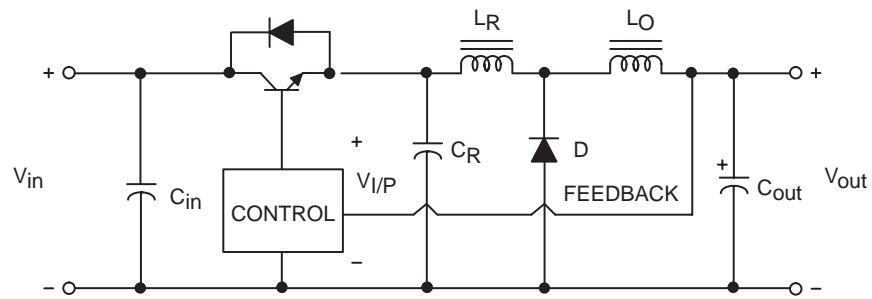

A ZCS Quasi-Resonant Buck Converter

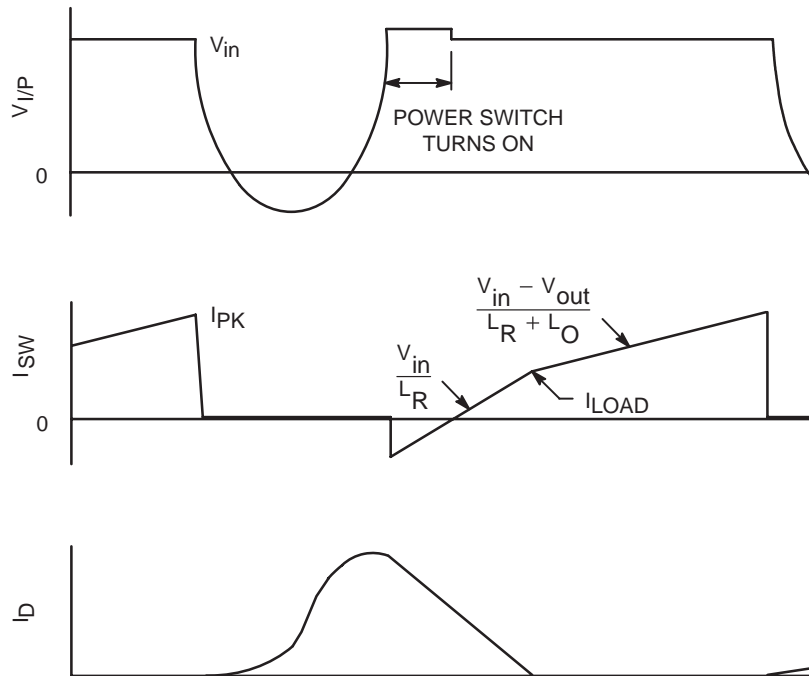

Figure 16. Schematic and Waveforms for a ZVS Quasi-Resonant Buck Converter

Losses and Stresses within Switching Power Supplies

Much of the designer's effort during a switching power supply design is spent in identifying and minimizing the losses within the supply. Some of these losses can also present stresses to the semiconductor power components which may affect the long term reliability of the power supply. Knowing where the losses arise and how to control them is important.

Most of the losses occur in the power components within the switching power supply. The most fragile components are the power semiconductors. Identifying the major sources for loss can be as easy as placing a finger on each of the components, or measuring the currents and voltages associated with each power component using an oscilloscope AC current probe and voltage probe. Whenever there is a simultaneous voltage drop across a component with a current flowing through it, there is a loss. Some of these losses are controllable by

modifying the circuitry, and some are controlled by simply selecting a different part.

The semiconductor losses fall into two categories: conduction losses and switching losses. Examples of conduction losses are the saturation voltage of a bipolar power transistor, the "on" loss of a power MOSFET shown in Figure 17 and Figure 18 and the forward voltage drop of a rectifier shown in Figure 19. Switching losses occur during the small period when a power component switches between the on and off state. Here, voltages are transitional between full-on and cutoff states while simultaneously the current is transitional between full-on and cutoff states. This creates a very large V-I product which is as significant as the conduction losses. Switching losses are also the major frequency dependent loss within every PWM switching power supply.

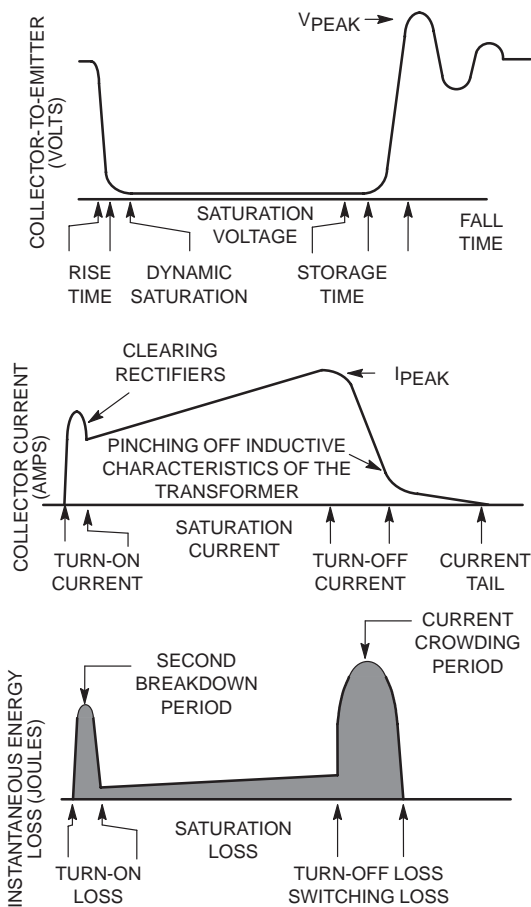

Figure 17. Stresses and Losses within a Bipolar Power Transistor

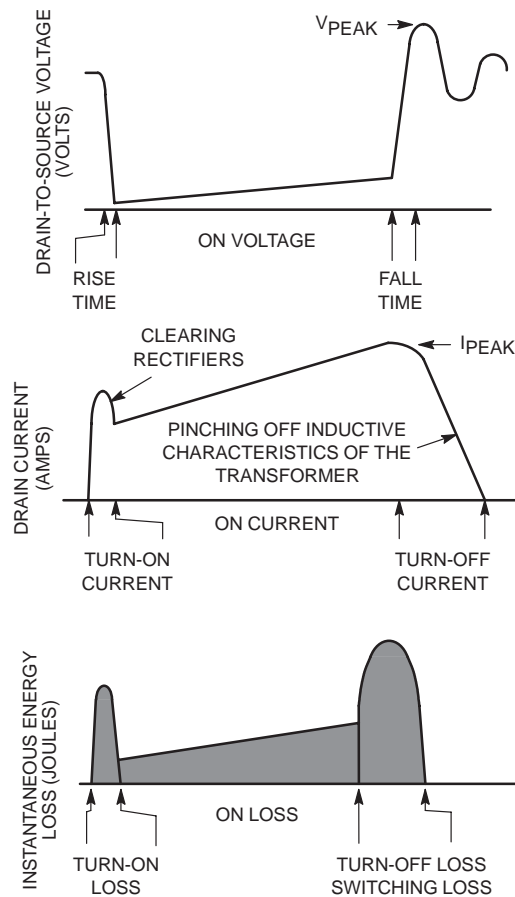

Figure 18. Stresses and Losses within a Power MOSFET

Losses and Stresses within Switching Power Supplies (continued)

The losses do provide stress in the form of heat generation within the component. This is not a problem if a reasonable thermal design is used. For bipolar power transistors, however, excessive switching losses can also provide a lethal stress to the transistor in the form of second breakdown and current crowding failures. Care should be taken in the careful analysis of each transistor's FBSOA and RBSOA operation.

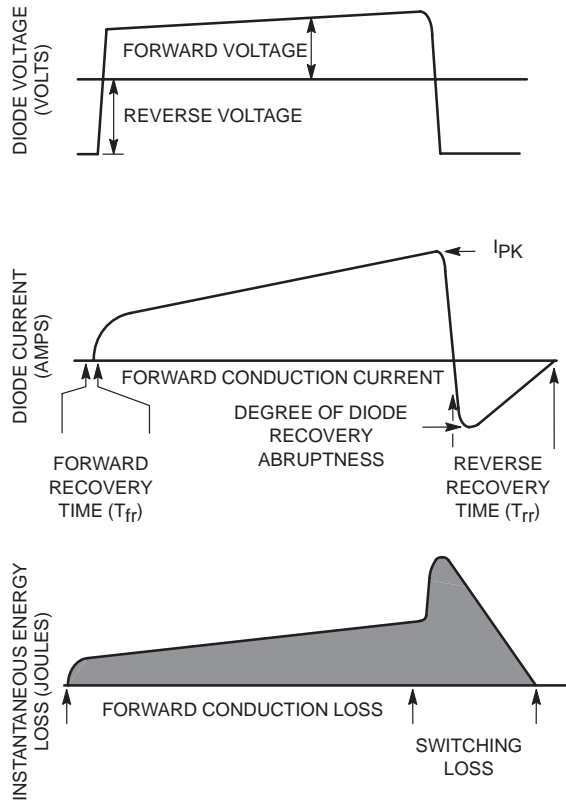

Figure 19. Stresses and Losses within Rectifiers

Bipolar Power Transistors

Bipolar power transistors are used in about 50 percent of the switching power supplies built today. They offer several advantages over power MOSFETs in that they have higher breakdown voltages, and are somewhat less expensive for devices greater than 500 volts.

Bipolar power transistors are current driven devices. That is, in order to have a current flowing from the collector to the emitter, one must drive current into the base. Within switching power supplies, the objective is to have as small a collector-to-emitter voltage as possible when the transistor is “on”. To do this the designer strives to have the transistor operate in, or close to a saturated state.

Saturation is defined as:

$$I_B > \frac{I_C}{h_{FE}}$$

There are two types of base drive: *fixed base drive* and *proportional base drive*. In most switching power supplies using bipolar transistors whose output power is less than 500 watts, fixed base drive is typically used. Fixed base drive is where the transistor is driven with a fixed amount of “on” drive current sufficiently high to guarantee that the transistor remains saturated at the highest expected peak collector currents. At collector currents less than the maximum, the transistor exhibits a condition known as *storage time* which is a time delay during the turning off of the transistor and a slower fall time. For better performance, proportional base drive is used. This drives the transistor to a state just under saturation at all peak currents. Very short storage time is experienced and its switching speed is substantially improved. Proportional base drive is more expensive to implement, so usually it is only used for high power switching power supplies. For the transistor to switch fast, the drive current should enter and exit the transistor fast. To accomplish this special attention should be given to the drive circuitry. Some common base drive circuits are shown in Figure 20.

Bipolar Power Transistors (continued)

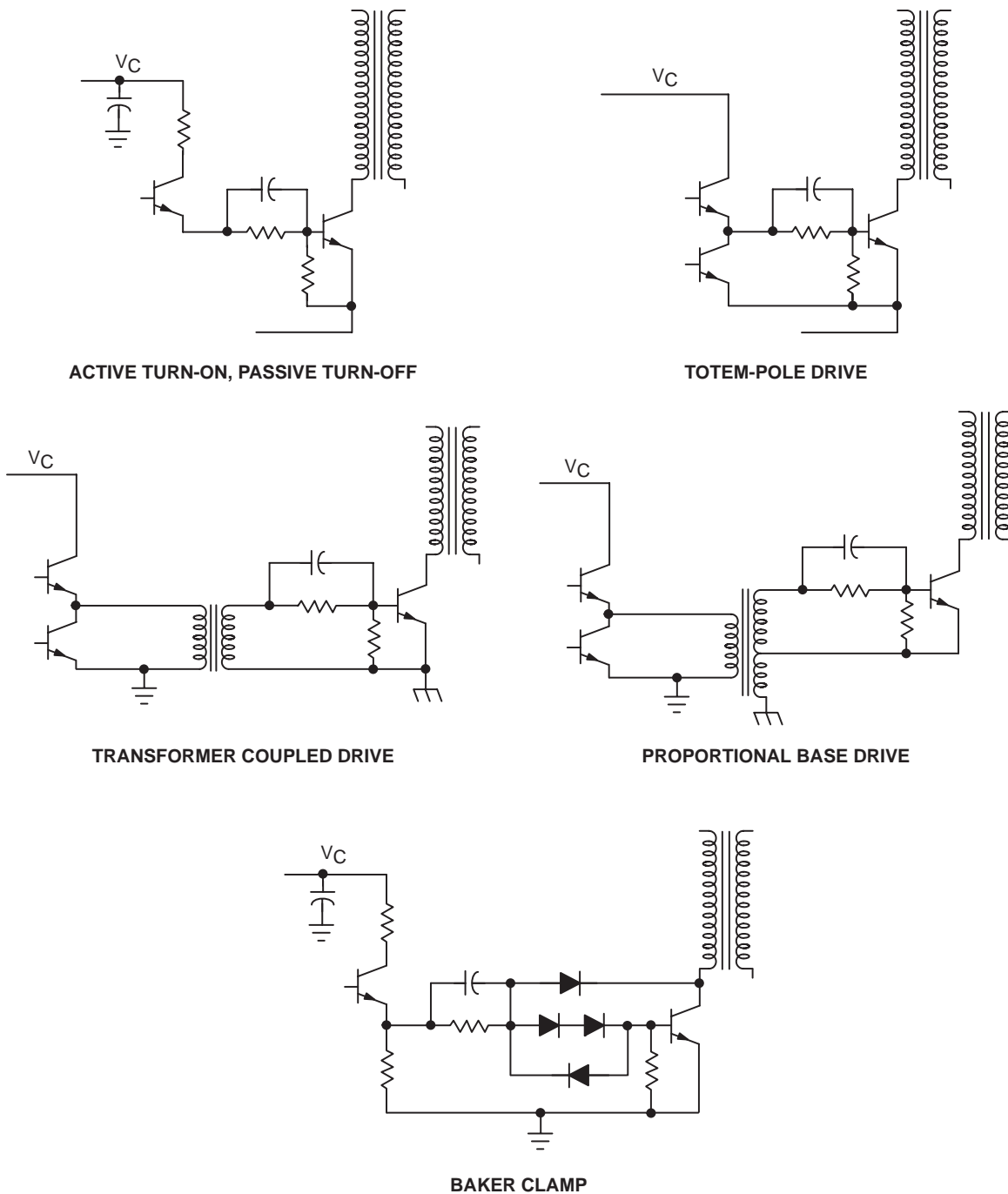

Figure 20. Common Transistor Base Drive Circuits

One other consideration is from where one draws the current to drive the base of the transistor. If a voltage of greater than 5 volts is used, then the loss associated with driving the base is large. Usually a low voltage auxiliary

winding is used to develop this voltage.

For more information, refer to Application Note AN875 (“Power Transistor Safe Operating Area: Special Considerations for Switching Power Supplies”).

Power MOSFETs

Power MOSFETs are becoming increasingly more popular for use as power switches within switching power supplies. MOSFETs have some advantages over the bipolar transistor such as switching five to ten times faster than bipolar transistors and being easier to drive and use. To the novice designer, it is as close to a logic switching device as one can get.

Power MOSFETs are voltage driven devices. That is its conductivity is determined by a voltage provided on its *gate*. MOSFETs can be driven directly from controller ICs that have totem pole output drivers with less than 100 nS switching times. The drive source, however, must

be a well bypassed voltage source. This is because the gate of a MOSFET resembles a capacitor which must be charged and discharged in that 100 nS. So it must be capable of sourcing and sinking at least 1.5 ampere peak currents. Bipolar totem pole drives fill this need. The MC34151 (inverting) and the MC34152 (non-inverting) MOSFET driver ICs provide the drive that MOSFETs need to switch fast with an input from a logic-level source. The MC33153 and MC33154 are specially designed gate drivers for IGBTs. See Figure 21 for some of the common gate drives for MOSFETS.

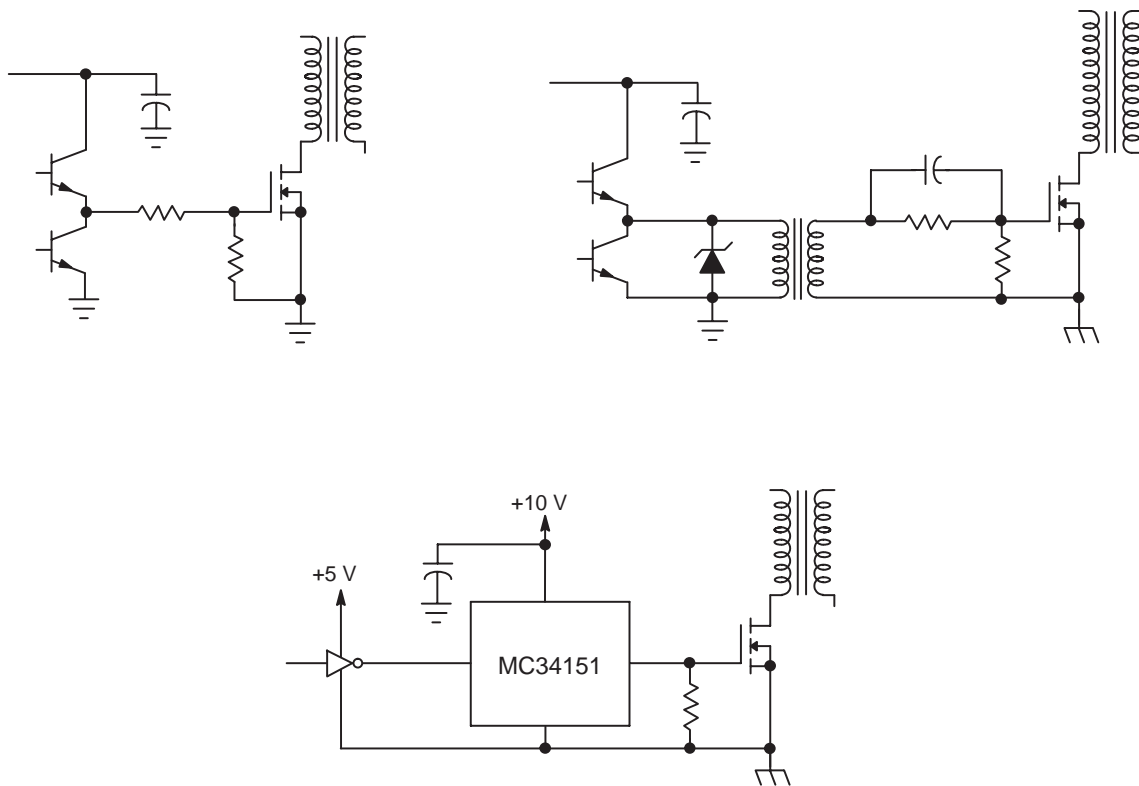

Figure 21. Power MOSFET Drive Circuits

Rectifiers

Choosing the best rectifiers for any switching power supply design is an important process. The rectifiers are the largest source of loss within switching power supplies. To choose the the best rectifier, one must understand the parameters that affect their efficiency.

The most important rectifier parameters are the *forward voltage drop* (V_f) and the *reverse recovery time* (t_{rr}). The forward voltage drop creates a loss just by having a voltage across the device while high currents are flowing through it.

Its conduction loss is described by:

$$P_{\text{fwd-loss}} = f_{\text{op}} \cdot \int_{t=0}^{t_{\text{on}}} V_{\text{fwd}} dt$$

The typical method of measuring this loss is to

graphically multiply the current and voltage waveforms from the oscilloscope times the frequency of operation.

The reverse recovery loss is where the rectifier becomes reverse biased, and current appears to actually flow backwards through the rectifier. It is actually the minority carriers being swept from the P-N junction. Nonetheless, it is a significant loss. This loss is minimized by selecting the rectifier with the shortest reverse recovery time (t_{rr}).

Table 3 shows a summary of the various rectifier technologies that are appropriate in switching power supplies. For low voltage outputs, Schottky rectifiers are recommended because of their low forward voltage drop and their negligible reverse recovery time. For higher output voltages, the ultrafast recovery rectifiers are recommended because of their very fast reverse recovery times.

Table 3. Comparative Information on Rectifiers

Rectifier Technology	Forward Voltage (Volts)	Reverse Recovery Time (nS)	Forward Recovery Time (nS)	Relative Cost
Fast Recovery	1.0	150	1050	1.0
UltraFast Recovery	0.9	75	50	1.5
Megahertz	1.6	28	—	2.0
Schottky	0.5	<1.0	—	1.6

Methods of Control

There are two popular methods of control for PWM switching power supplies. These center around the parameters sensed within the switching supply; current or voltage can be sensed to provide consistent output voltages. ON Semiconductor offers switching power supply controller ICs which provide a choice of the control method.

Voltage-Mode Control

Voltage-mode control is where only the output voltage is sensed in order to maintain its required voltage level. This type of control can be recognized by the output of the error amplifier going into a comparator that compares the error voltage with the ramp created by the oscillator section of the IC. The comparator, sometimes called the *PWM comparator*, converts the error voltage into a

pulsewidth modulated waveform in order to drive the power switches in a pulsewidth modulated on/off fashion. The most common voltage-mode control is a fixed frequency method of control as shown in Figure 22. Examples of this type of controller are the MC34060A, MC34166 and TL494.

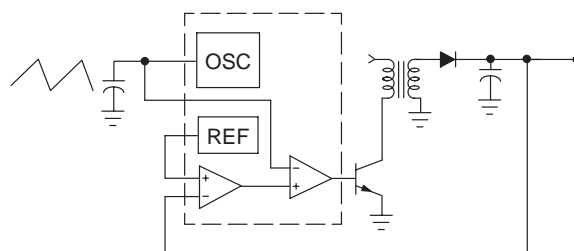

Figure 22. Voltage-Mode Control

Methods of Control (continued)

Another voltage-mode control method used in quasi-resonant switching power supplies is variable frequency control as shown in Figure 23. This is a voltage-mode control since only the output voltage is sensed and the output duty cycle (on or off times per second) is controlled. This includes either fixed on-time, variable off-time (ZCS) or fixed off-time, variable on-time (ZVS). Examples of control ICs for this type of control are the MC34066P(ZCS) and MC34067P(ZVS).

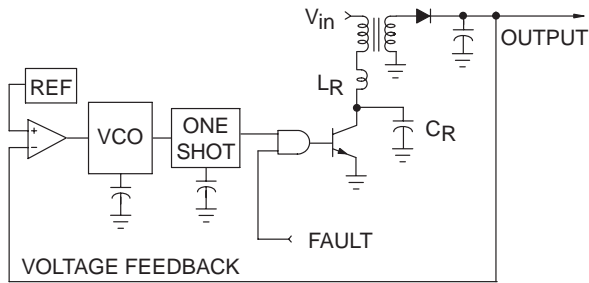

Figure 23. Variable Frequency, Voltage-Mode Control

Voltage-mode control is the traditional method. Although it provides good output regulation (good response to changes in the output load), it is somewhat sluggish to changes in the input voltage, and has trouble sensing a core saturation condition.

Current-Mode Control

Current-mode control is somewhat new. It senses not only the output voltage, but the amount of current that flows through the inductor or transformer. When the output demands more power, the controller allows more current to enter the inductor or transformer. Conversely, if the input voltage suddenly changes, it is immediately detected by the controller and responds, keeping the output voltage at its required level. The common method of current-mode control is called *turn-on with clock current-mode control*. This means that the frequency of operation is determined by an oscillator whose only purpose is to start each “on” cycle.

Current-mode controllers can be identified by the output of the error amplifier being placed into a comparator where the level of the current ramp is sensed (I_s) as shown in Figure 24.

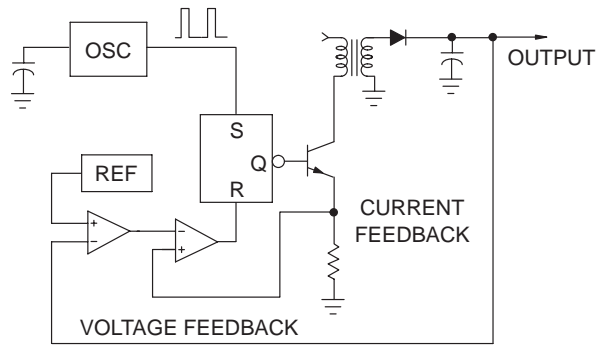

Figure 24. Current-Mode Control

This method of control is very fast and provides a very good *transient response time*; that is, the time it takes to respond to changes on either the supply input or output. It tends to be a very robust control method, responding quickly to short-circuit and overload conditions without failures to the supply. Examples of these parts are the UC3842/3/4/5, MC34023, MC34025 and the MC34129.

Gated Oscillator Control

Gated oscillator control is a unique, but effective method of control which is used on several of the ON Semiconductor control ICs. The typical control circuit of this type is shown in Figure 25. It is a form of variable frequency control with pulse-by-pulse overcurrent limiting. The IC has a fixed frequency oscillator, but its output is gated on or off depending upon whether the output is below the needed output or above the needed output. It exhibits the robustness of current-mode control since each pulse is current limited. Examples of these types of parts are the UA78S40, MC34063A and MC34163.

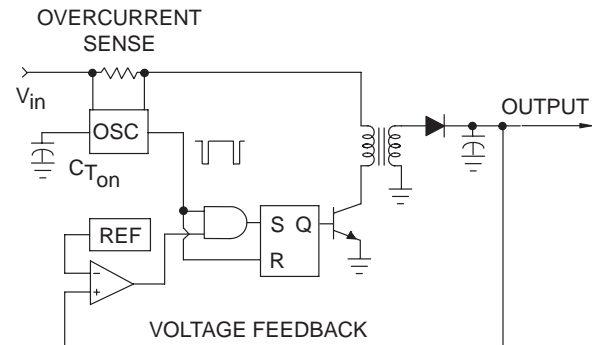

Figure 25. Gated Oscillator Control

Optoisolated Voltage Feedback

Optoisolators are utilized within switching power supplies for passing signals over isolated boundaries. The areas of common usage are analog voltage feedback across isolated power circuits, drive signals to floating devices, and passing control signals between isolated circuits. Optoisolators are made up of a light emitting diode (LED) and a transistor exposed to the LED's light via a light path medium. Its primary parameter is the *current transfer ratio* (CTR). This specifies how much current one can expect from the output given a current being passed through the LED. Its unit is percent.

The inclusion of isolated outputs and voltage feedback circuits in high input voltages and off-line switching power supplies is required by the safety regulatory agencies. Optoisolators are used most frequently for the isolated voltage feedback circuits.

Unfortunately, because of the physical limitations of the technology, the optoisolator's CTR can drift with temperature and age. To compensate for this, an error amplifier should be placed on the output prior to the optoisolator. This will place the optoisolator inside the feedback loop and compensate for any drift that occurs within the optoisolator. A popular circuit which accomplishes this is shown in Figure 26.

One issue that faces the designer with this method of voltage feedback is how much gain is used and where to place the feedback loop compensation in the circuit since there are two error amplifiers within the loop. Since the TL431 is difficult to compensate, it is recommended that the TL431 be limited to half the needed high frequency gain and then place the compensation on the second error amplifier within the controller IC.

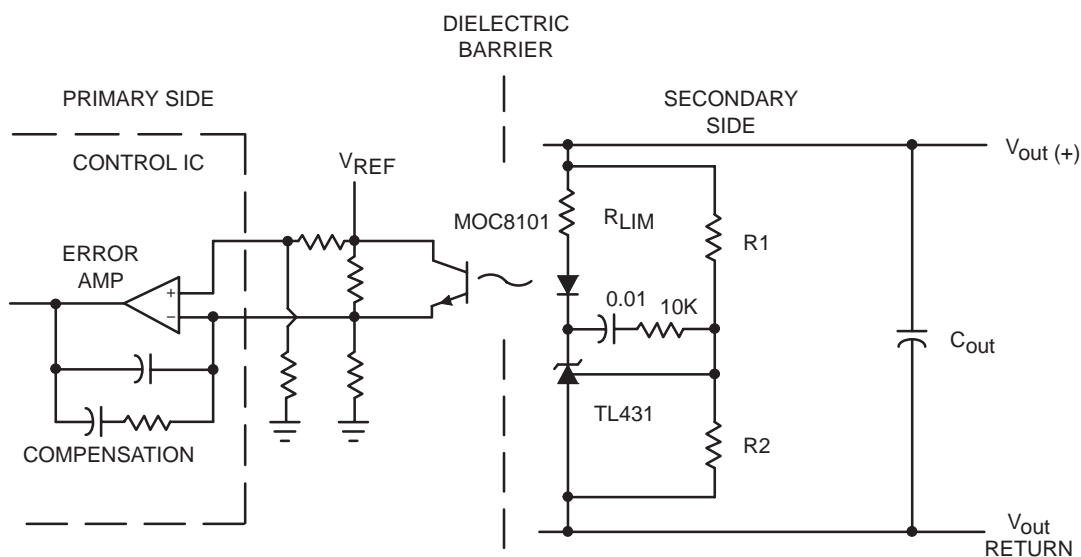

Figure 26. Opto Isolated Voltage Feedback for Off-line Switching Power Supplies

First-Pass Selection of Semiconductors

By using Table 4, it is possible to make reasonable choices for the power semiconductors prior to the switching power supply being designed. Each topology presents its own unique set of voltage and current conditions which can be predicted with reasonable certainty. This allows the designer to select the most appropriate power semiconductors very early in the design cycle with a high degree of confidence. Early

procurement of these samples will avoid delivery delays within the design period.

The results of each of the defined parameters outlined in Table 4 should be considered as minimum parameter values. Parameters such as breakdown voltage ratings should have a margin for any voltage spikes generated by the supply.

Table 4. Estimating the Significant Parameters of the Power Semiconductors

Topology	Bipolar Power Switch		MOSFET Power Switch		Rectifier(s)	
	V _{CEO}	I _C	V _{DSS}	I _D	V _R	I _F
Buck	V _{in}	I _{out}	V _{in}	I _{out}	V _{in}	I _{out}
Boost	V _{out}	$\frac{2.0P_{out}}{V_{in(min)}}$	V _{out}	$\frac{2.0P_{out}}{V_{in(min)}}$	V _{out}	I _{out}
Buck/Boost	V _{in} - V _{out}	$\frac{2.0P_{out}}{V_{in(min)}}$	V _{in} - V _{out}	$\frac{2.0P_{out}}{V_{in(min)}}$	V _{in} - V _{out}	I _{out}
Flyback	1.7 V _{in(max)}	$\frac{2.0P_{out}}{V_{in(min)}}$	1.5 V _{in(max)}	$\frac{2.0P_{out}}{V_{in(min)}}$	10 V _{out}	I _{out}
1 Transistor Forward	2.0 V _{in}	$\frac{1.5P_{out}}{V_{in(min)}}$	2.0 V _{in}	$\frac{1.5P_{out}}{V_{in(min)}}$	3.0 V _{out}	I _{out}
Push-Pull	2.0 V _{in}	$\frac{1.2P_{out}}{V_{in(min)}}$	2.0 V _{in}	$\frac{1.2P_{out}}{V_{in(min)}}$	2.0 V _{out}	I _{out}
Half-Bridge	V _{in}	$\frac{2.0P_{out}}{V_{in(min)}}$	V _{in}	$\frac{2.0P_{out}}{V_{in(min)}}$	2.0 V _{out}	I _{out}
Full-Bridge	V _{in}	$\frac{1.2P_{out}}{V_{in(min)}}$	V _{in}	$\frac{1.2P_{out}}{V_{in(min)}}$	2.0 V _{out}	I _{out}

Other Design Considerations

Transformers and Inductors

The magnetic elements are the cornerstone of all switching power supply designs but are also the least understood. There are three types of magnetic components inside switching power supplies: a forward-mode transformer or a flyback-mode transformer, an AC filter inductor, and a DC filter inductor. Each has its own design approach. Although the design of each of these magnetic components can be approached in an organized step-by-step fashion, it is beyond the intent of this guide. For further information regarding their design, refer to the “Practical Switching Power Supply Design” reference book.

The design and the winding technique used in the magnetic component’s design has a great bearing on the reliability of the overall power supply. Two situations arise from a poor transformer design; high voltage spikes are generated by the rate of transitions in current within the switching supply, and the possibility of *core saturation* can arise during an abnormal operational mode. Voltage spikes are caused by a physically “loose” winding construction of a transformer. The power supply depends upon the quick transmission of transitions in current and voltage between the transformer windings. When the windings are physically wound distant from one another, the leakage inductances store and release a portion of the energy inputted into a winding in the form

of voltage spikes. It also delays the other windings from seeing the transition in the drive winding. Spikes can cause the semiconductors to enter *avalanche breakdown* and the part can instantly fail if enough energy is applied. It can also cause significant Radio Frequency Interference (RFI) problems. A snubber is usually the solution, but this lowers the efficiency of the power supply. Core saturation occurs when there are too few turns on a transformer or inductor. This causes the *flux density* to be too high and at high input voltages or long pulsewidths, the core can enter saturation. Saturation is when the core’s cross sectional area can no longer support additional lines of flux. This causes the permeability of the core to drop, and the inductance value to drop drastically. This makes the inductor or winding stop being an AC current limiting device and it turns into a short circuit. Hence, within microseconds, a nice linear current ramp can go from a few amps to tens or hundreds of amps thus causing the semiconductor switch to fail. Indications of this condition can be determined by placing an oscilloscope current probe on the winding and if the linear current waveform begins to exponentially rise upwards, then the saturation condition is being entered. One then needs to revisit the design and in most cases add more turns to the windings.

Other Design Considerations (continued)

Cores

Cores come in many shapes and sizes. The three most common core types are shown in Figure 27. There are many more types, but they are all based upon these basic styles. Some of the important considerations when selecting a core type are core material, cost, the output power of the power supply, the physical volume the transformer or inductor must fit within, and the amount of RFI shielding the core must provide.

For modern switching power supplies the commonly used core materials are F, K, & N materials from Magnetics, Inc., 3C8, & 3C85 from FerroxCube, Inc. or H7C4 & H7C40 materials from TDK. These ferrite materials offer the lowest core losses at the operating frequencies between 80 KHz to 1.0 MHz.

When selecting the style of the core, the designer should not only consider the initial cost of the core itself, but the labor costs associated with manufacturing the transformer or inductor. Bobbin style cores are generally more expensive to buy, but generally require less labor to manufacture. Torroid cores are less expensive initially,

but require special equipment to manufacture the transformer or inductor and more labor.

Torroid cores radiate less RFI energy than many of bobbin cores, and thus may aid in the physical RFI design later in the design. For transformers that require airgaps, some ferrite, bobbin cores offer better RFI shielding than others, such as the pot core and those cores derived from pot cores. The pot core offers less wire winding area than the E-E core families. So tradeoffs abound at this stage of the design.

One thing to keep in mind during this phase of a switching power supply design is that it is next to impossible to make a wrong choice since all of the cores can be made to work in the applications. Even the determinations of the number of turns should be considered a *calculated guess*. Only the turns on the secondary of a transformer need to be somewhat precise in order to get the output voltages needed by the power supply.

Note: Finished inductive devices are easy to order in large volume from several winding suppliers.

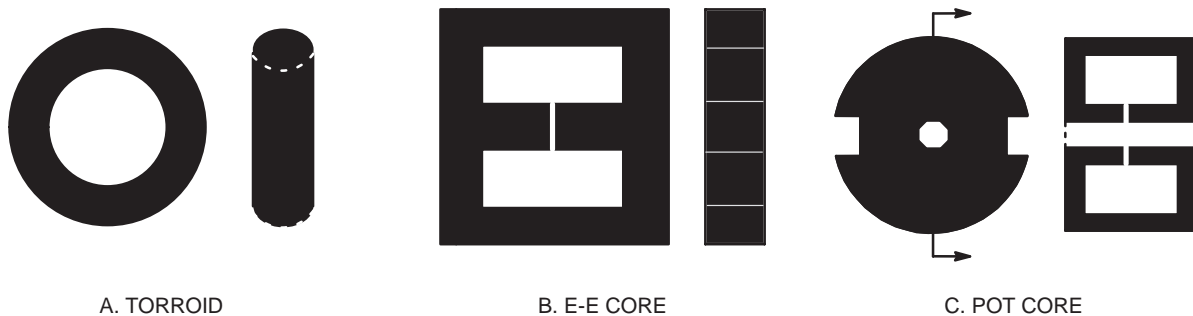

Figure 27. Common Core Types

Other Design Considerations (continued)

Snubbers and Clamps

Snubbers and clamps are used for two very different purposes. When misapplied, the reliability of the semiconductors within the power supply is greatly jeopardized.

A snubber is used for reducing the level of a voltage spike and decreasing the rate of change of a voltage waveform. This has its benefits in the Safe Operating Area (SOA) of the semiconductors, and it lowers the spectral content of any radiated RFI thus radiating less RF energy.

A clamp is used only for reducing the level of a voltage spike. It has no effect on the dV/dt of the transition. Therefore it is not very useful for reducing RFI. It is useful

for preventing components such as semiconductors and capacitors from entering avalanche breakdown.

Bipolar power transistors suffer from *current crowding* which is an instantaneous failure mode. If a voltage spike occurs during the turn-off voltage transition of greater than 75 percent of its V_{CEO} rating, it may have too much current crowding stress. Here both the rate of change of the voltage and the peak voltage of the spike must be controlled. A snubber is needed to bring the transistor within its RBSOA rating.

Typical snubber and clamp circuits are shown in Figure 28. The effects that these have on a representative switching waveform are shown in Figure 29.

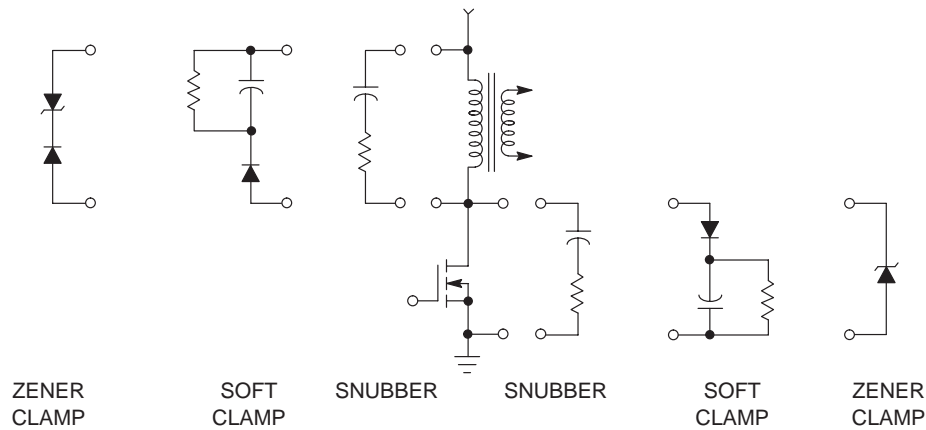

Figure 28. Common Methods for Controlling Voltage Spikes and/or RFI

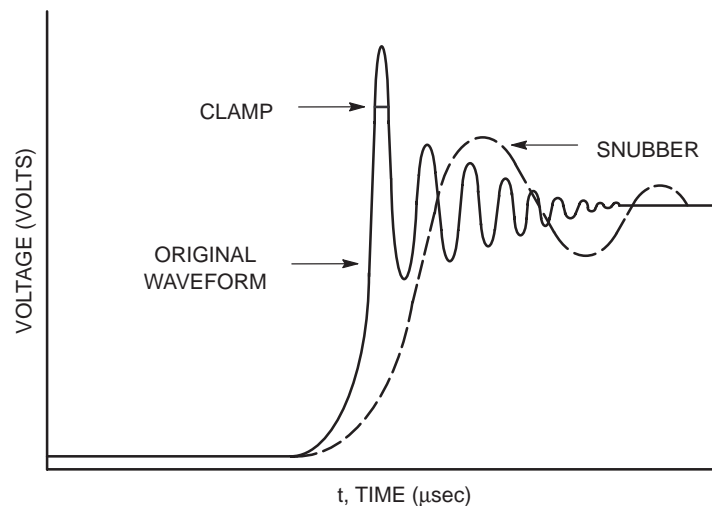

Figure 29. The Effects of a Snubber versus a Clamp

Other Design Considerations (continued)

The Printed Circuit Board Layout

The printed circuit board (PCB) layout is the third most sensitive portion of every switching power supply design following the basic design and the magnetics design. The lack of quality in its layout can adversely affect RFI radiation, component reliability, efficiency and stability.

First, all PCB traces exhibit inductance and resistance. These can cause high voltage transitions whenever there is a high rate of change in current flowing through the trace. For operational amplifiers sharing a trace with power signals, it means that the supply would be impossible to stabilize. For traces that are too narrow for the current flowing through them, it means a voltage drop from one end of the trace to the other which potentially can be an antenna for RFI.

There are two rules of thumb for PCB layouts: “short and fat” for all power carrying traces and “one point grounding” for the three different types of grounds within a switching power supply. Traces that are short and fat minimize the inductive and resistive aspects of the trace, thus reducing noise within the circuits and RFI. One point grounding keeps the noise sources separated from the sensitive control circuits. The three types of grounds are the input power return ground, the output power return ground and the low-level control ground.

Attention should be paid to the layout around the filter capacitors. If paralleled capacitors are in a line, the capacitor closest to the source of the ripple current will get hot, the other won't see this level of AC current and thus won't evenly share the ripple current. Any paralleled capacitors should be laid out radially symmetric about the ripple current source which is typically a rectifier or power switch.

Off-line Switching Power Supply Design and Safety Tips

Any power supply that operates from an input voltage of greater than 30 VAC or 42.5 VDC is considered a

hazard to its operator and must be inspected, qualified, and approved by the relevant safety regulatory body for the anticipated market. In the U.S. it is UL, in Canada it is the CSA, and in Europe VDE is the common agency. Designing for safety has definite affects on the physical design of the switching power supply. One should pursue knowledgeable consultants or acquire the relevant safety specifications.

Safety factors affect the design and construction of the power supplies. The key factors are the physical separation of the input power source to the outputs and any component that allows the passing of 50/60 Hz AC current from the input to the output. The construction and design of the transformer, PCB and the enclosure are affected. Schematically it is the input filter design and the feedback and signaling design.

The important terms used by the regulatory agencies are, *creepage*, *clearance*, *dielectric strength* or *Hipot*. Creepage is the distance between two isolated points along a surface. Clearance is the separation distance between two isolated points in air. Dielectric strength is the voltage breakdown testing of all components that are connected between isolated circuits. The test consists of applying a high AC or DC voltage between the input and the output and earth ground and checking that the current conducted is less than the specified amount. It is recommended that a DC HIPOT test be used when testing all switching power supplies due to possible AC avalanche problems.

When the designer is debugging an off-line power supply on the bench, several personal safety precautions must be followed.

- Use an isolation transformer between the wall socket and the power supply.
- Float the earth ground leads on the power cords of ALL test equipments.
- Do not hook the scope or test equipments between grounds. Disconnect all signal wires and relocate them.

SWITCHMODE Power Supply Examples

This section provides both initial and detailed information to simplify the selection and design of a variety of SWITCHMODE power supplies. The ICs for Switching Power Supplies figure identifies control, reference voltage, output protection and switching regulator ICs for various topologies.

	Page
<i>ICs for Switching Power Supplies</i>	30
Integrated circuits identified for various sections of a switching power supply.	
<i>Suggested Components for Specific Applications</i>	31
A list of suggested control ICs, power transistors and rectifiers for SWITCHMODE power supplies by application.	
• CRT Display System	32
• AC/DC Power Supply for CRT Displays	33
• AC/DC Power Supply for Storage, Imaging & Entertainment	33
• DC–DC Conversion	34
• Typical PC Forward–Mode SMPS	35
<i>Real SMPS Applications</i>	
80 W Power Factor Correction Controller	36
Compact Power Factor Correction	37
Monitor Pulsed–Mode SMPS	38
70 W Wide Mains TV SMPS	40
100 W Wide Mains TV SMPS with 1.3 W Stand–by	42
Low–Cost Off–line IGBT Battery Charger	44
110 W Output Flyback SMPS	45
Efficient Safety Circuit for Electronic Ballast	47
Lamp Ballast with Power Factor Correction (Evaluation Board)	49
AC–DC Battery Charger – Constant Current with Voltage Limit	51

Some of these circuits may have a more complete application note, spice model information or even an evaluation board available. Consult ON Semiconductor’s website (<http://onsemi.com>) or local sales office for more information.

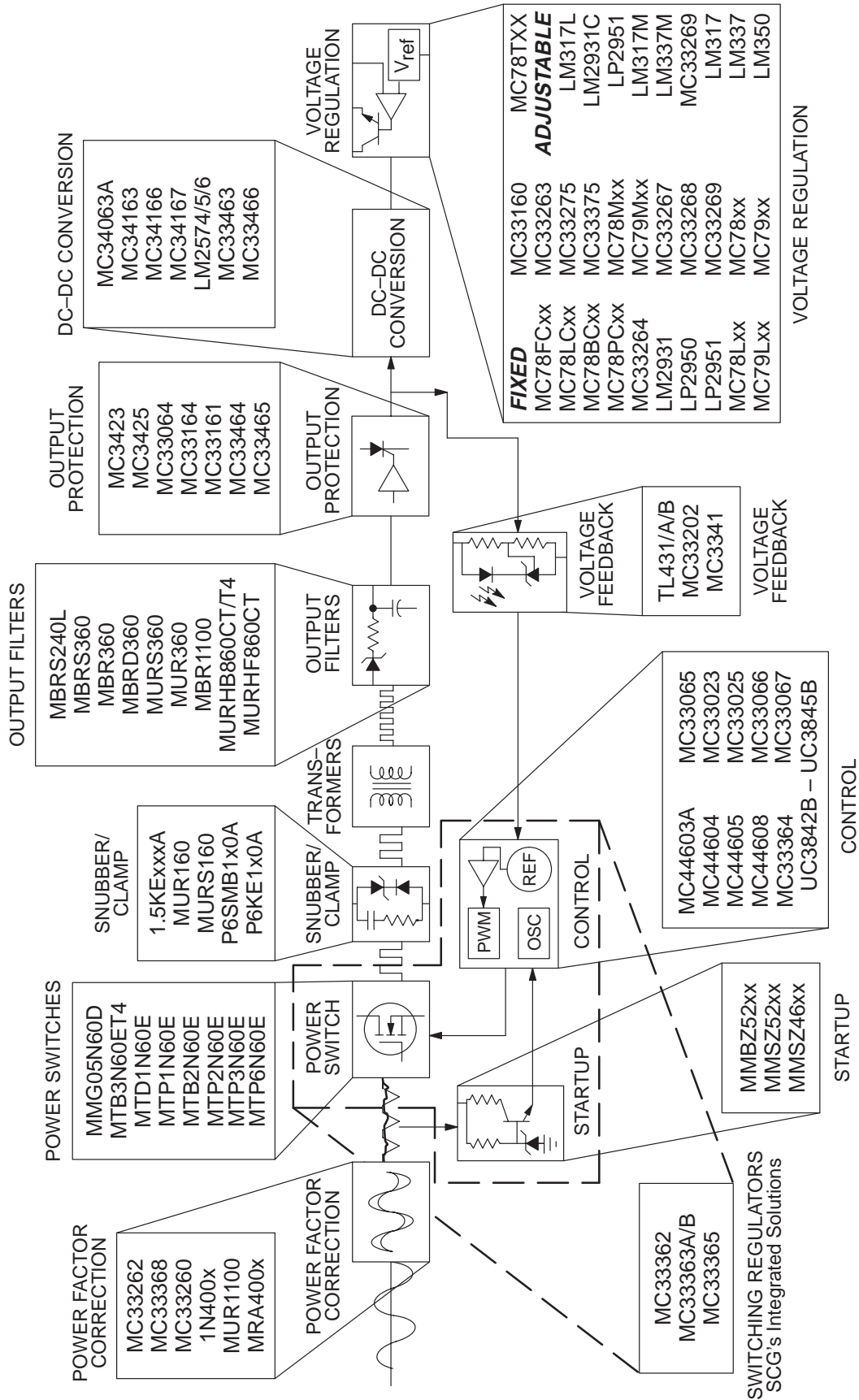

Figure 30. Integrated Circuits for Switching Power Supplies

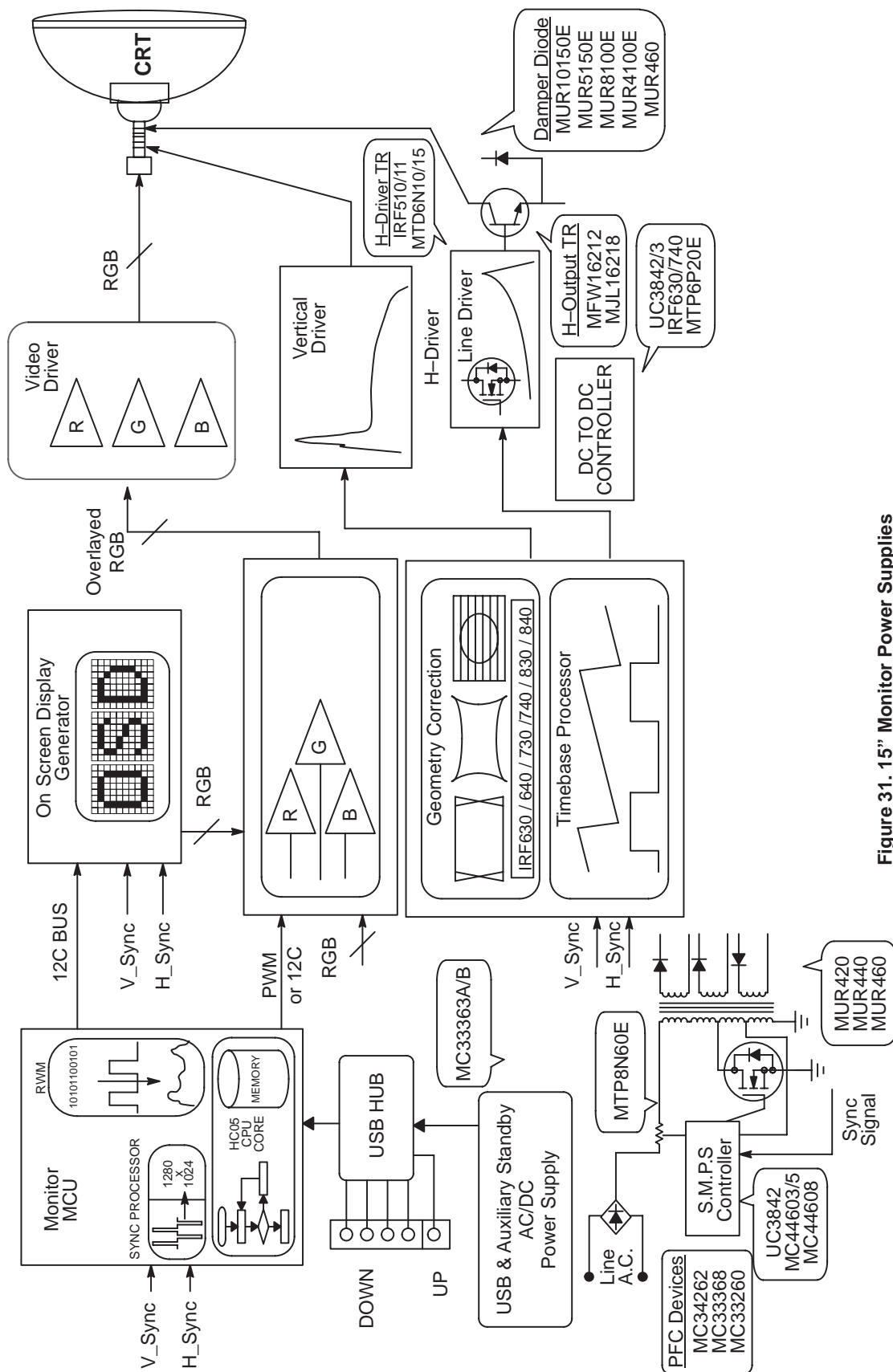

Figure 31. 15" Monitor Power Supplies

SMPSRM

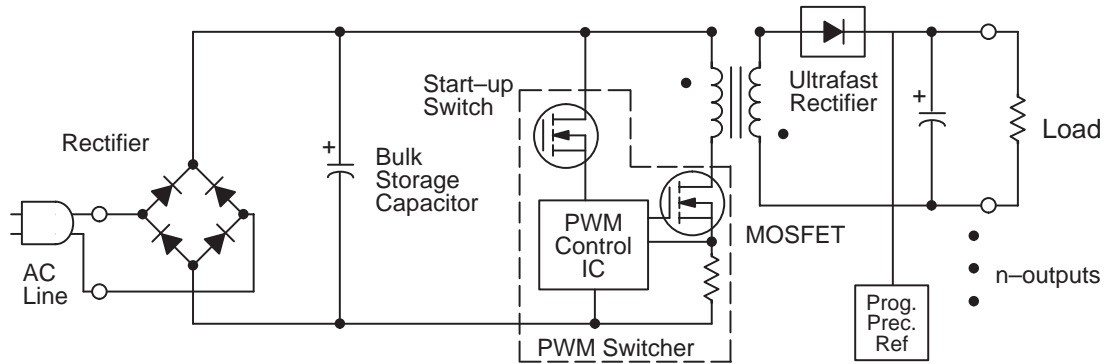

Figure 32. AC/DC Power Supply for CRT Displays

Table 5.

Part #	Description	Key Parameters	Samples/Prod.
MC33262	PFC Control IC	Critical Conduction PFC Controller	Now/Now
MC33368	PFC Control IC	Critical Conduction PFC Controller + Internal Start-up	Now/Now
MC33260	PFC Control IC	Low System Cost, PFC with Synchronization Capability, Follower Boost Mode, or Normal Mode	Now/Now
MC33365	PWM Control IC	Fixed Frequency Controller + 700 V Start-up, 1 A Power Switch	Now/Now
MC33364	PWM Control IC	Variable Frequency Controller + 700 V Start-up Switch	Now/Now
MC44603A/604	PWM Control IC	GreenLine, Sync. Facility with Low Standby Mode	Now/Now
MC44605	PWM Control IC	GreenLine, Sync. Facility, Current-mode	Now/Now
MC44608	PWM Control IC	GreenLine, Fixed Frequency (40 kHz, 75 kHz and 100 kHz options), Controller + Internal Start-up, 8-pin	Now/2Q99
MTP6N60E	MOSFET	600 V, 6 A, $R_{ds(on)} = 1.2 \text{ V}$	Now/Now
MTW14N50E	MOSFET	500 V, 14 A, $R_{ds(on)} = 0.4 \text{ V}$	Now/Now
MSR860	Ultrasoft Rectifier	600 V, 8 A, $t_{rr} = 55 \text{ ns}$, $I_r \text{ max} = 1 \text{ uA}$	Now/Now
MUR440	Ultrafast Rectifier	400 V, 4 A, $t_{rr} = 50 \text{ ns}$, $I_r \text{ max} = 10 \text{ uA}$	Now/Now
MRA4006T3	Fast Recovery Rectifier	800 V, 1 A, $V_f = 1.1 \text{ V @ } 1.0 \text{ A}$	Now/Now
MR856	Fast Recovery Rectifier	600 V, 3 A, $V_f = 1.25 \text{ V @ } 3.0 \text{ A}$	Now/Now

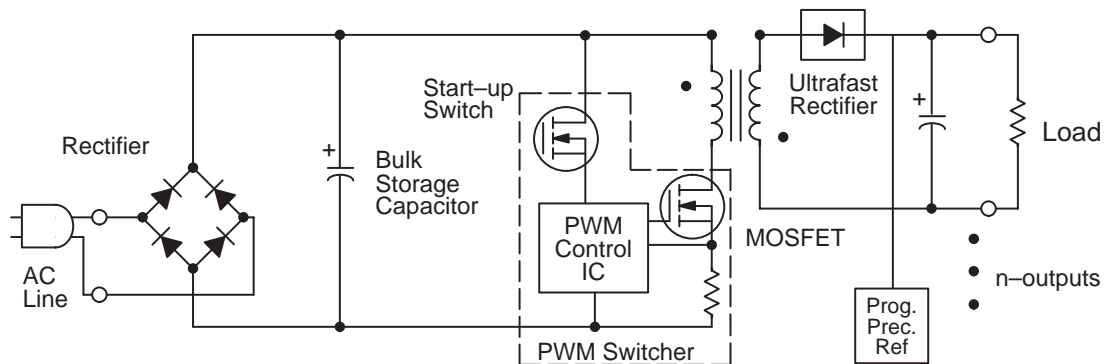

Figure 33. AC/DC Power Supply for Storage, Imaging & Entertainment

Table 6.

Part #	Description	Key Parameters	Samples/Prod.
MC33363A/B/65	PWM Control IC	Controller + 700 V Start-up & Power Switch, < 15 W	Now/Now
MC33364	PWM Control IC	Critical Conduction Mode, SMPS Controller	Now/Now
TL431B	Program Precision Reference	0.4% Tolerance, Prog. Output up to 36 V, Temperature Compensated	Now/Now
MTP6N60E	MOSFET	600 V, 6 A $R_{ds(on)} = 1.2$	Now/Now
MSRD620CT	Ultrasoft Rectifier	200 V, 6 A, $t_{rr} = 55$ ns, $I_r \text{ max} = 1$ μ A	Now/Now
MR856	Fast Recovery Rectifier	600 V, 3 A, $V_f = 1.25$ V @ 3.0 A	Now/Now

SMPSRM

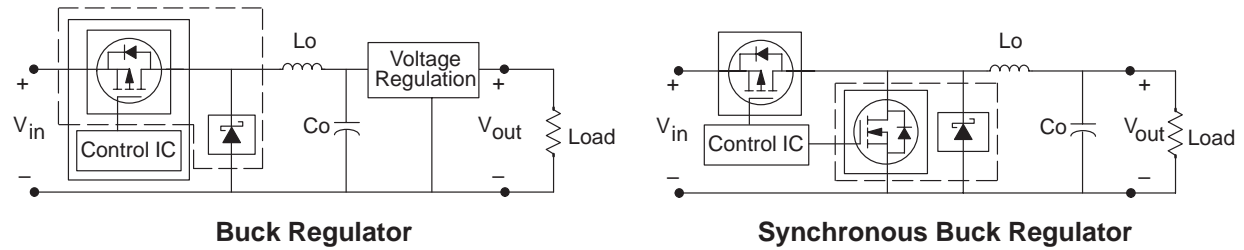

Figure 34. DC – DC Conversion

Table 7.

Part #	Description	Key Parameters	Samples/Prod.
MC33263	Low Noise, Low Dropout Regulator IC	150 mA; 8 Outputs 2.8 V – 5 V; SOT 23L 6 Lead Package	Now/Now
MC33269	Medium Dropout Regulator IC	0.8 A; 3.3; 5, 12 V out; 1 V diff; 1% Tolerance	Now/Now
MC33275/375	Low Dropout Regulator	300 mA; 2.5, 3, 3.3, 5 V out	Now/2Q99
LP2950/51	Low Dropout, Fixed Voltage IC	0.1 A; 3, 3.3, 5 V out; 0.38 V diff; 0.5% Tolerance	Now/Now
MC78PC	CMOS LDO Linear Voltage Regulator	I _{out} = 150 mA, Available in 2.8 V, 3 V, 3.3 V, 5 V; SOT 23 – 5 Leads	Now/Now
LM2574/75/76	Control IC w/integrated FET	0.5 – 3 A; 7 – 40 V in; 3.3, 5, 12, 15 & adj out	Now/Now
MC33470	Synchronous Buck Regulator IC	Digital Controlled; V _{CC} = 7 V; Fast Response	Now/Now
MMDFS2P102R2	P–Ch FET w/Schottky in SO–8	20 V, 2 A, 160 mΩ FET/1 A, Vf = 0.46 V Schottky	Now/Now
MMDFS6N303R2	N–Ch FET w/Schottky in SO–8	30 V, 6 A, 35 mΩ FET/3 A, Vf = 0.42 V Schottky	Now/Now
MMDFS3P303R2	P–Ch FET w/Schottky in SO–8	30 V, 3 A, 100 mΩ FET/3 A, Vf = 0.42 V Schottky	Now/Now
MBRM140T3	1A Schottky in Powermite Package	40 V, 1 A, Vf = 0.43 @ 1 A; Ir = 0.4 mA @ 40 V	Now/Now
MBRA130LT3	1A Schottky in SMA Package	40 V, 1 A, Vf = 0.395 @ 1 A; Ir = 1 mA @ 40 V	Now/Now
MBRS2040LT3	2A Schottky in SMB Package	40 V, 2 A, Vf = 0.43 @ 2 A; Ir = 0.8 mA @ 40 V	Now/Now
MMSF3300	Single N–Ch MOSFET in SO–8	30 V, 11.5 A ⁽¹⁾ , 12.5 mΩ @ 10 V	Now/Now
MMSF3302	Single N–Ch MOSFET in DPAK	30 V, 18.3 A ⁽¹⁾ , 10 mΩ @ 10 V	Now/Now
MTSF2P03HD	Single P–Ch MOSFET in Micro 8 Package	30 V, 2.7 A, 90 mΩ @ 10 V	Now/Now
MGSF3454X/V	Single N–Ch MOSFET in TSOP–6	30 V, 4.2 A, 65 mΩ @ 10 V	Now/Now
MGSF3441X/V	Single P–Ch MOSFET in TSOP–6	20 V, 3.3 A, 100 mΩ @ 4.5 V	Now/Now

(1) Continuous at T_A = 25° C, Mounted on 1" square FR–4 or G10, V_{GS} = 10 V t ≤ 10 seconds

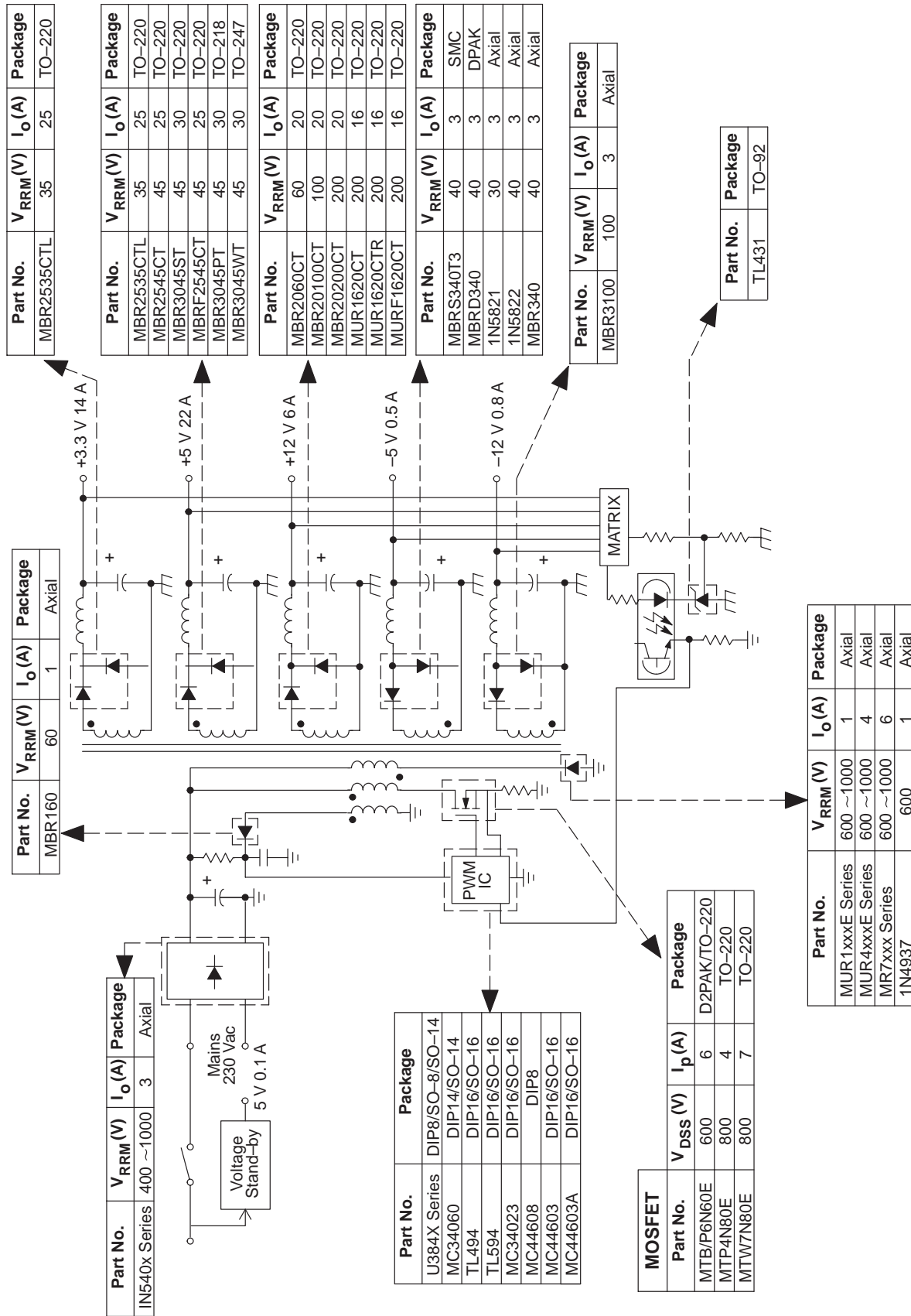

Figure 35. Typical 200 W ATX Forward Mode SMPS

SMPSRM

Application: 80 W Power Factor Controller

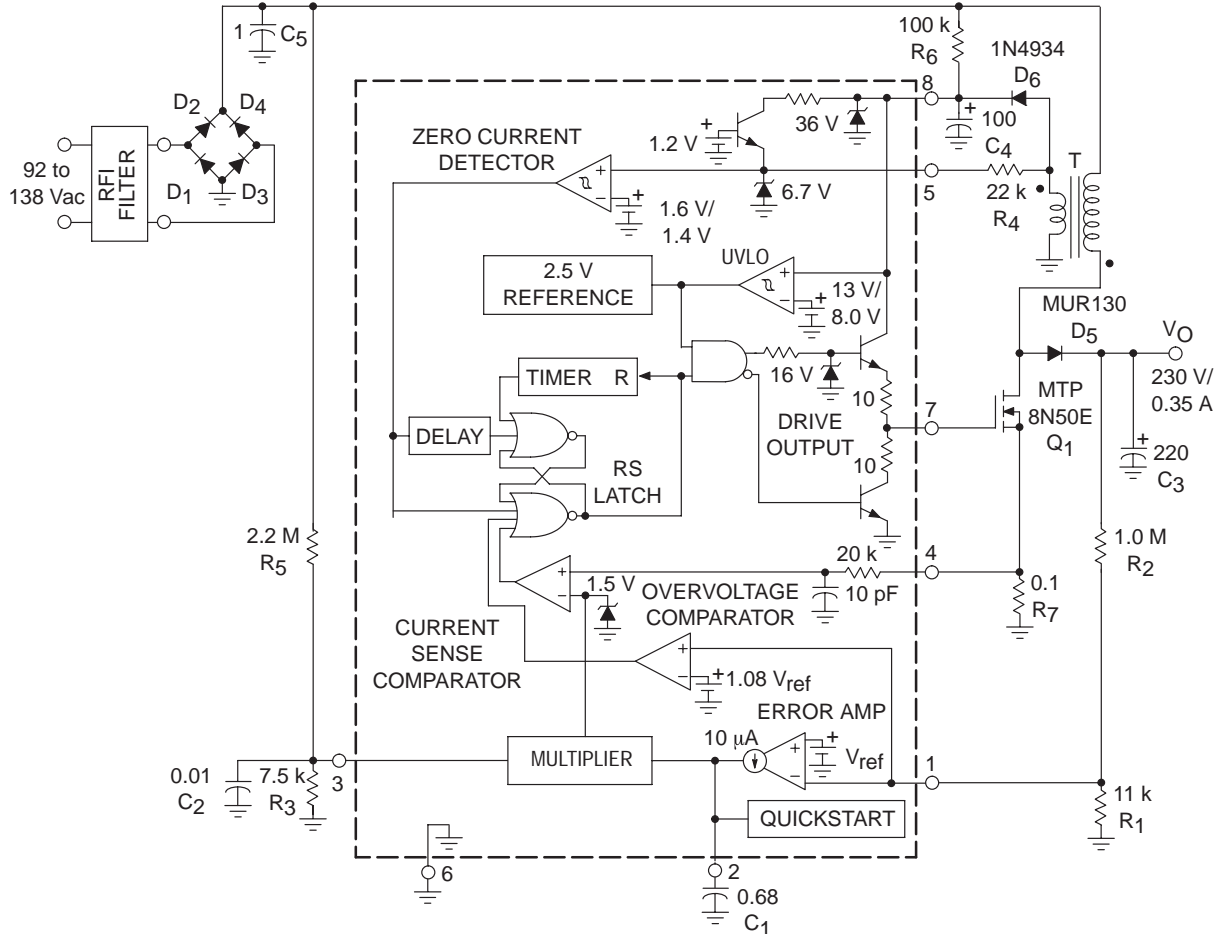

Figure 36. 80 W Power Factor Controller

Features:

Reduced part count, low-cost solution.

ON Semiconductor Advantages:

Complete semiconductor solution based around highly integrated MC33262.

Devices:

Part Number	Description
MC33262	Power Factor Controller
MTP8N50E	TMOS™ Power MOSFET
MUR130	Axial Lead Ultrafast Recovery Rectifier (300 V)
Transformer	Coilcraft N2881-A Primary: 62 turns of #22 AWG Secondary: 5 turns of #22 AWG Core: Coilcraft PT2510 Gap: 0.072" total for a primary inductance (Lp) of 320 μH

Application: Compact Power Factor Correction

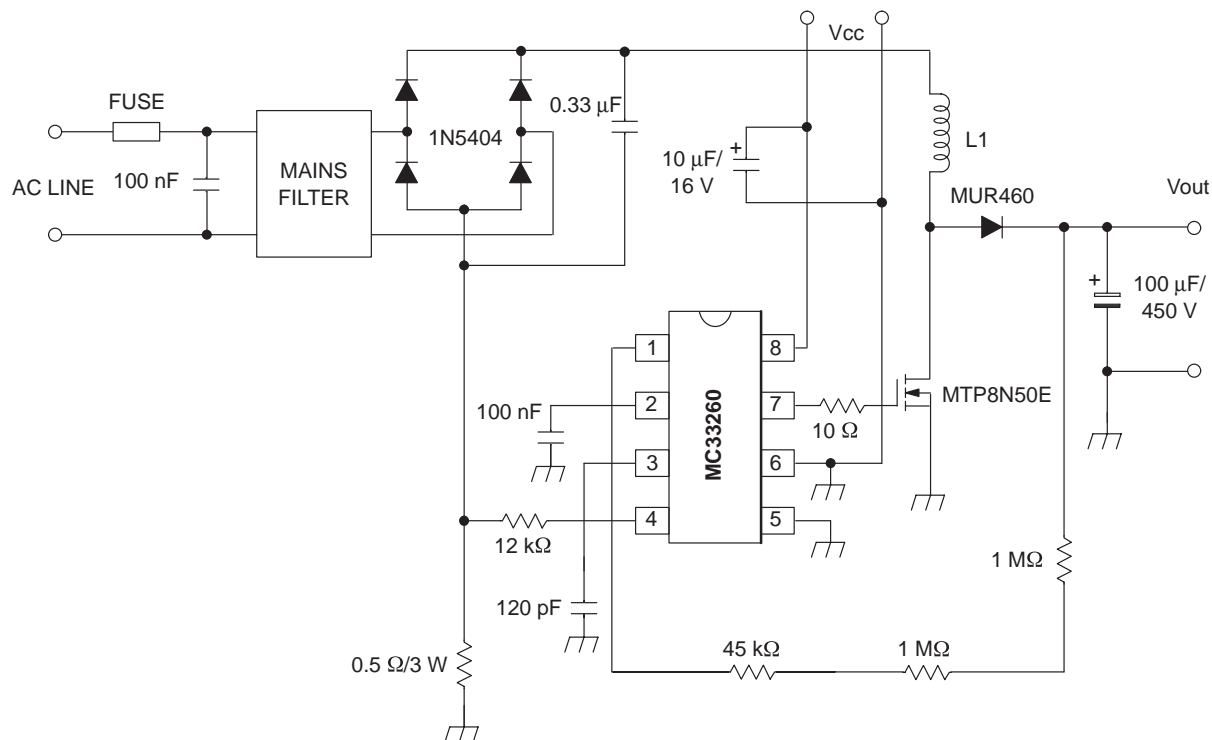

Figure 37. Compact Power Factor Correction

Features :

- Low-cost system solution for boost mode follower.
- Meets IEC1000-3-2 standard.
- Critical conduction, voltage mode.
- Follower boost mode for system cost reduction – smaller inductor and MOSFET can be used.
- Inrush current detection.
- Protection against overcurrent, overvoltage and undervoltage.

ON Semiconductor advantages:

- Very low component count.
- No Auxiliary winding required.
- High reliability.
- Complete semiconductor solution.
- Significant system cost reduction.

Devices:

Part Number	Description
MC33260	Power Factor Controller
MTP8N50E	TMOS™ Power Field Effect Transistor (N-Channel)
MUR460	Ultrafast Recovery Rectifier (600 V)
1N5404	General Purpose Rectifier (400 V)

Application: Monitor Pulsed-Mode SMPS

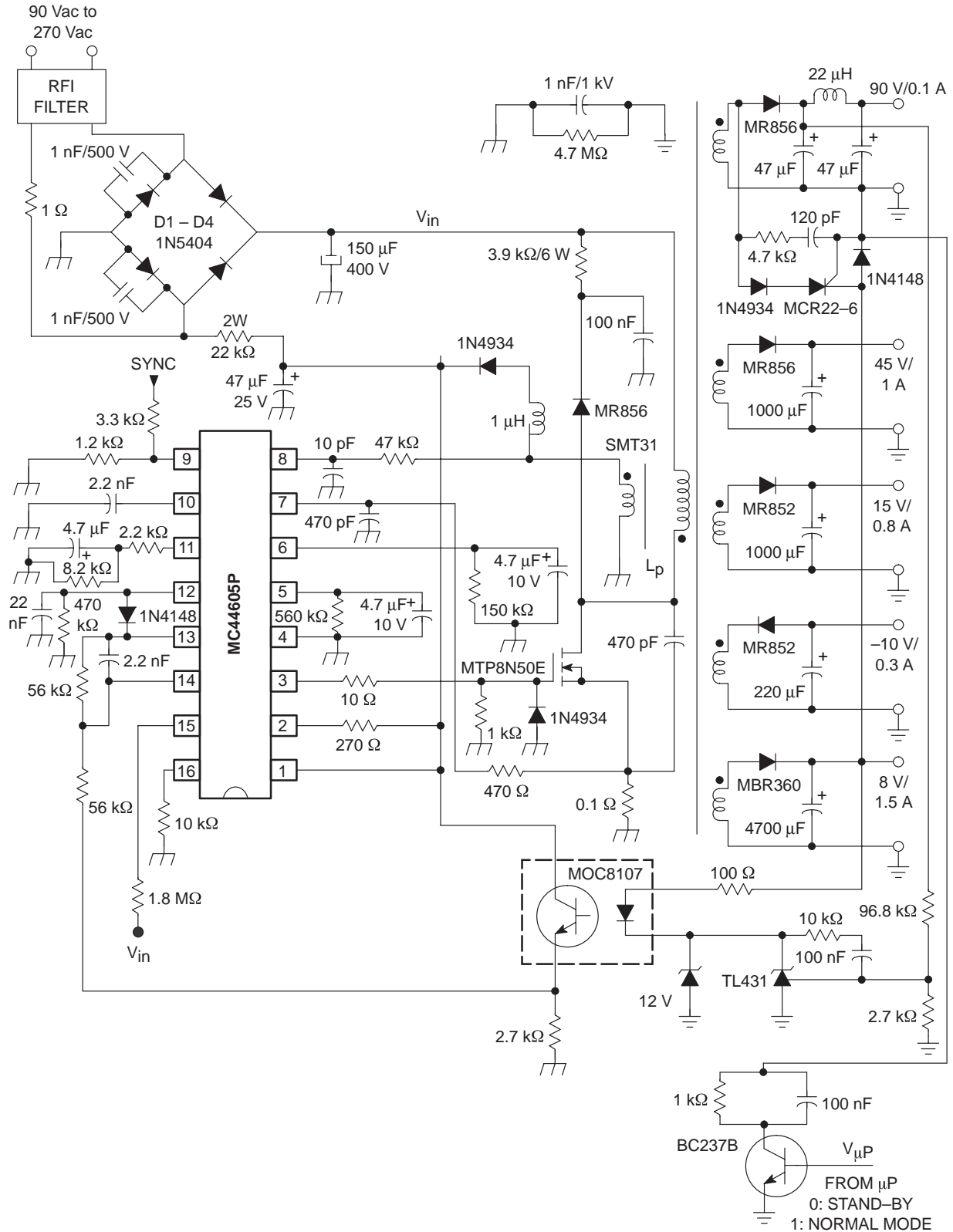

Figure 38. Monitor Pulsed-Mode SMPS

Features:

Off power consumption: 40 mA drawn from the 8 V output in Burst mode.

Vac (110 V) → about 1 watt

Vac (240 V) → about 3 watts

Efficiency (pout = 85 watts)

Around 77% @ Vac (110 V)

Around 80% @ Vac (240 V)

Maximum Power limitation.

Over-temperature detection.

Winding short circuit detection.

ON Semiconductor Advantages:

Designed around high performance current mode controller.

Built-in latched disabling mode.

Complete semiconductor solution.

Devices:

Part Number	Description
MC44605P	High Safety Latched Mode GreenLine™ Controller For (Multi) Synchronized Applications
MTP8N50E	TMOS™ E-FET™ Power Field Effect Transistor (N-Channel)
TL431	Programmable Precision Reference
MR856	Fast Recovery Rectifier (600 V)
MR852	Fast Recovery Rectifier (200 V)
MBR360	Axial Lead Schottky Rectifier (60 V)
BC237B	NPN Bipolar Transistor
1N5404	General-Purpose Rectifier (400 V)
Transformer	G6351-00 (SMT31M) from Thomson Orega Primary Inductance: 207 μH Area: 190 nH/turns ² Primary Turns: 33 Turns (90 V): 31

SMPSRM

Application: 70 W Wide Mains TV SMPS

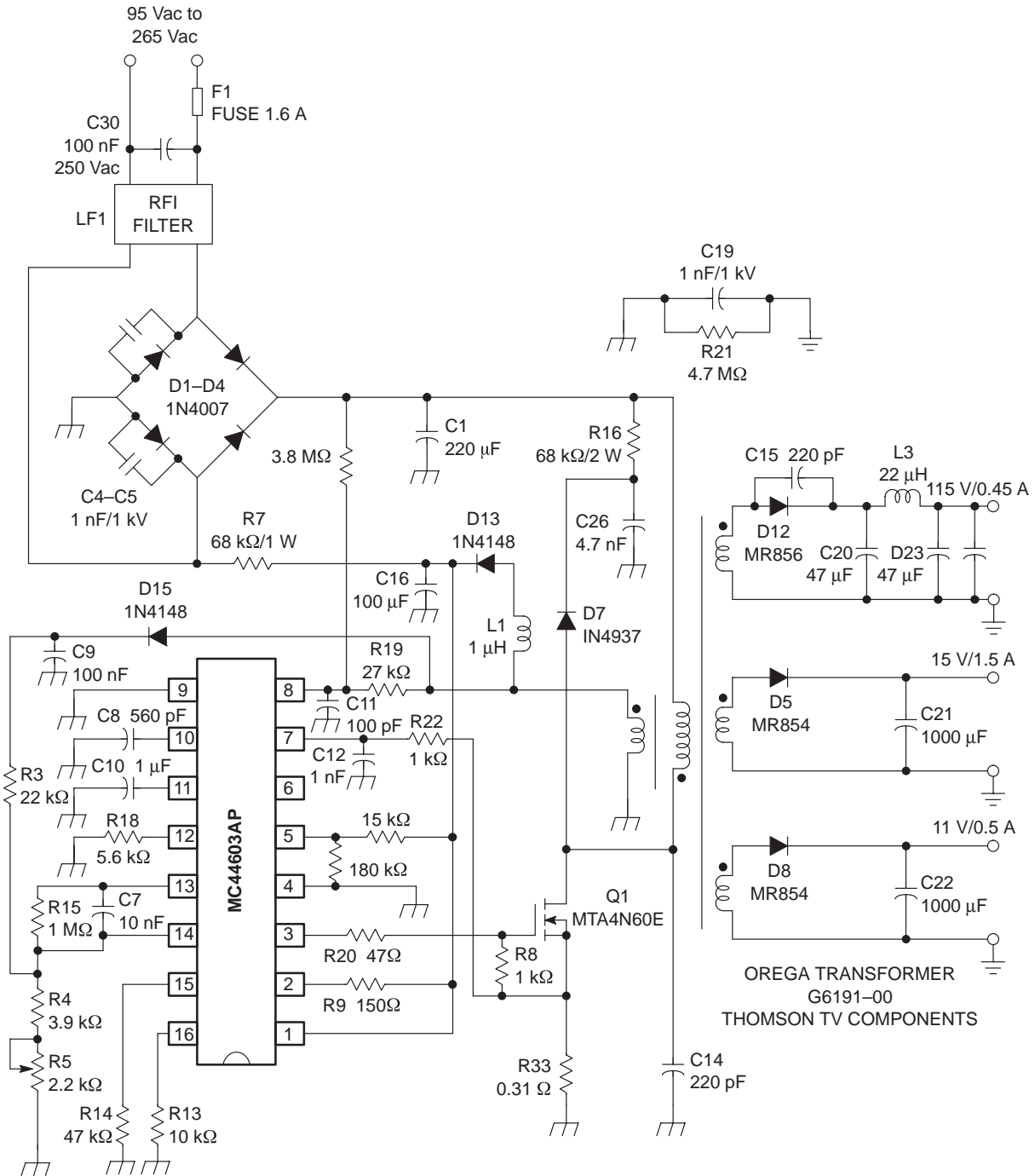

Figure 39. 70 W Wide Mains TV SMPS

Features:

70 W output power from 95 to 265 Vac.

Efficiency

@ 230 Vac = 86%

@ 110 Vac = 84%

Load regulation (115 Vac) = ± 0.8 V.

Cross regulation (115 Vac) = ± 0.2 V.

Frequency 20 kHz fully stable.

ON Semiconductor Advantages:

DIP16 or SO16 packaging options for controller.

Meets IEC emi radiation standards.

A narrow supply voltage design (80 W) is also available.

Devices:

Part Number	Description
MC44603AP	Enhanced Mixed Frequency Mode GreenLine™ PWM Controller
MTA4N60E	TMOS™ E-FET™ Power Field Effect Transistor (N-Channel)
MR856	Fast Recovery Rectifier (600 V)
MR854	Fast Recovery Rectifier (400 V)
1N4007	General Purpose Rectifier (1000 V)
1N4937	General Purpose Rectifier (600 V)
Transformer	Thomson Orega SMT18

SMPSRM

Application: Wide Mains 100 W TV SMPS with 1.3 W TV Stand-by

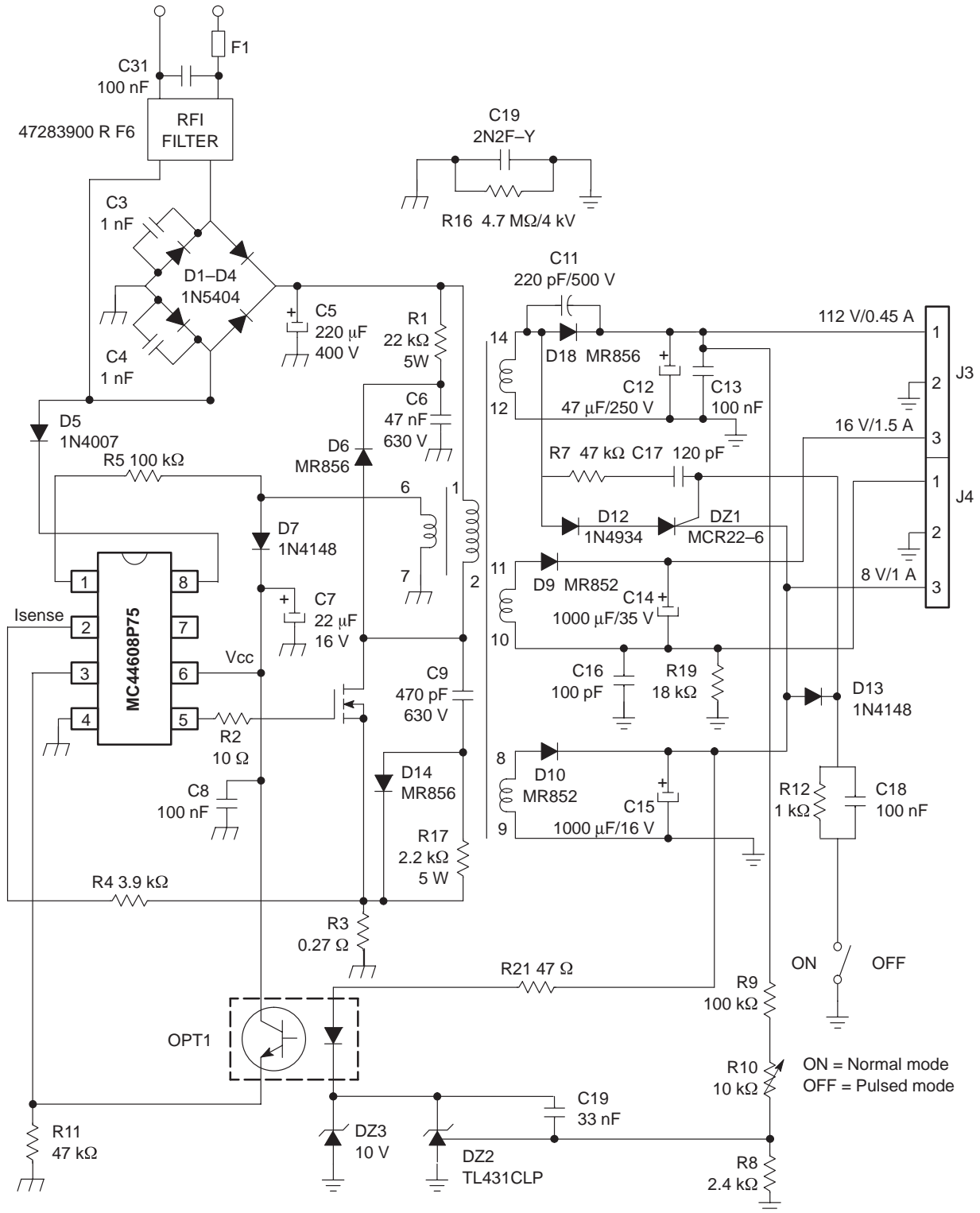

Figure 40. Wide Mains 100 W TV SMPS with Secondary Reconfiguration for 1.3 W TV Stand-by

Features:

- Off power consumption: 300mW drawn from the 8V output in pulsed mode.
- $P_{in} = 1.3W$ independent of the mains.
- Efficiency: 83%
- Maximum power limitation.
- Over-temperature detection.
- Demagnetization detection.
- Protection against open loop.

ON Semiconductor Advantages:

- Very low component count controller.
- Fail safe open feedback loop.
- Programmable pulsed-mode power transfer for efficient system stand-by mode.
- Stand-by losses independent of the mains value.
- Complete semiconductor solution.

Devices:

Part Number	Description
MC44608P75	GreenLine™ Very High Voltage PWM Controller
MTP6N60E	TMOS Power Field Effect Transistor (N-Channel)
TL431	Programmable Precision Reference
MR856	Fast Recovery Rectifier (600 V)
MR852	Fast Recovery Rectifier (200 V)
1N5404	General Purpose Rectifier (400 V)
Transformer	SMT19 40346-29 (9 slots coil former) Primary inductance: 181 mH N _{primary} : 40 turns N 112 V: 40 turns N 16 V: 6 turns N 8 V: 3 turns

Application: Low-Cost Offline IGBT Battery Charger

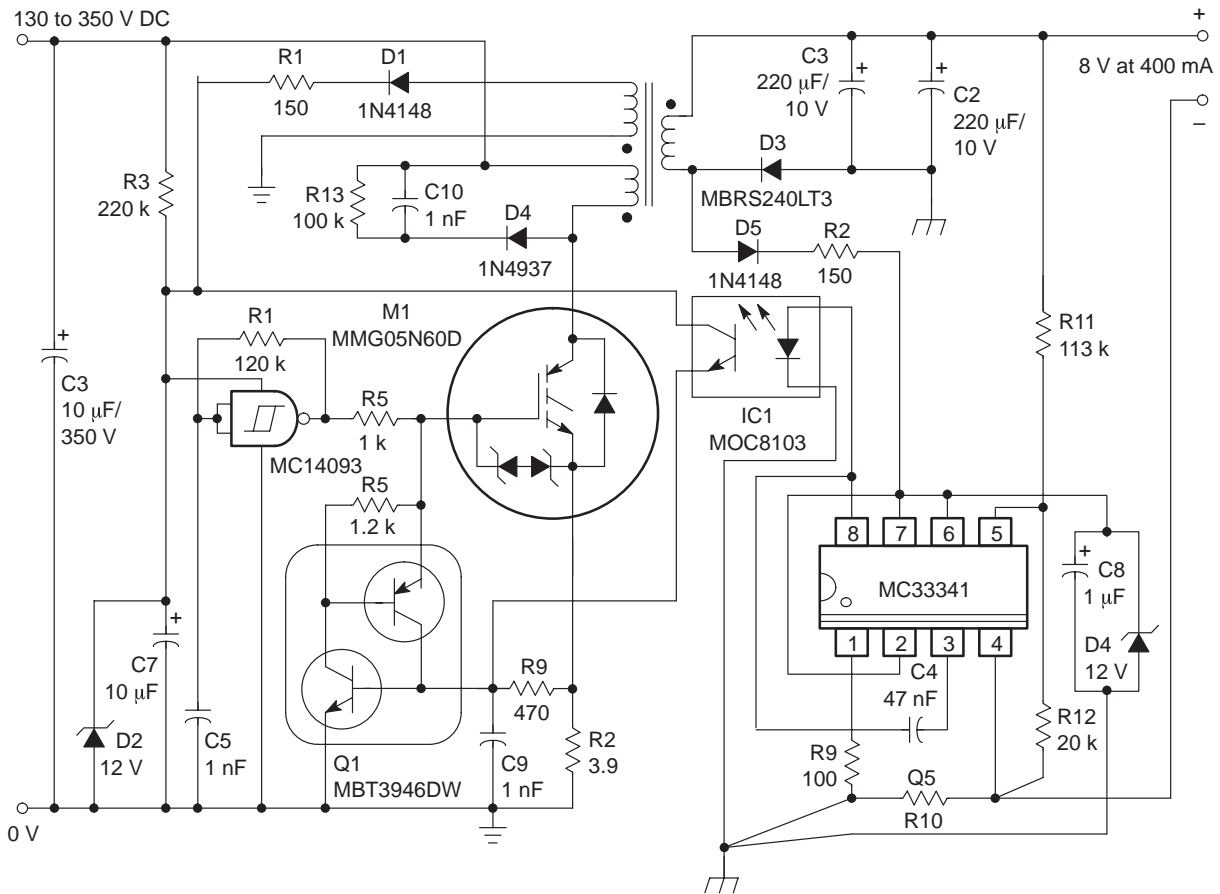

Figure 41. Low-Cost Offline IGBT Battery Charger

Features:

- Universal ac input.
- 3 Watt capability for charging portable equipment.
- Light weight.
- Space saving surface mount design.

ON Semiconductor Advantages:

- Special-process IGBT (Normal IGBTs will not function properly in this application).
- Off the shelf components.
- SPICE model available for MC33341.

Devices:

Part Number	Description
MMG05N60D	Insulated Gate Bipolar Transistor in SOT-223 Package
MC33341	Power Supply Battery Charger Regulator Control Circuit
MBT3946DW	Dual General Purpose (Bipolar) Transistors
MBS240LT3	Surface Mount Schottky Power Rectifier
MC14093	Quad 2-Input "NAND" Schmitt Trigger
1N4937	General-Purpose Rectifier (600 V)

Application: 110 W Output Flyback SMPS

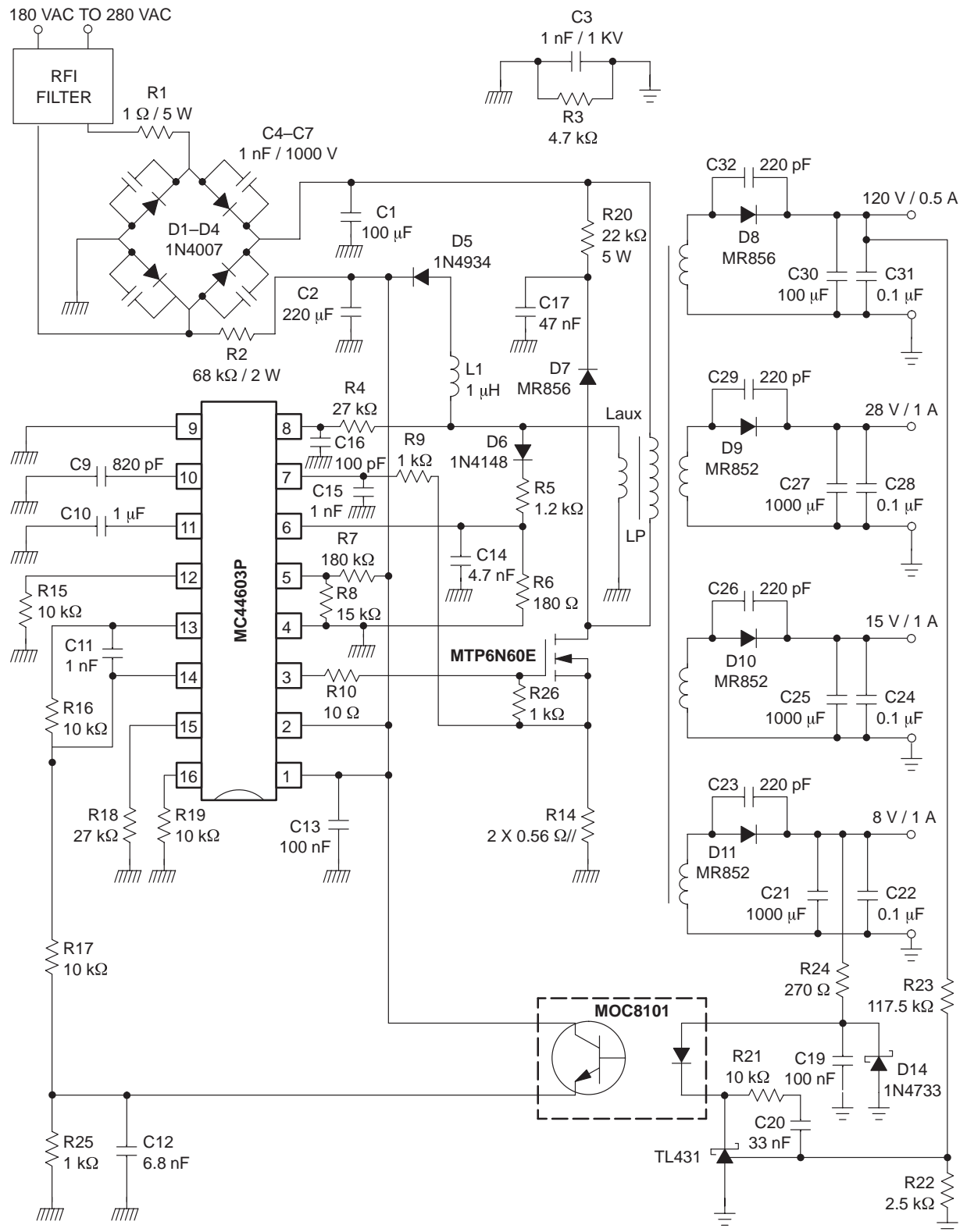

Figure 42. 110 W Output Flyback SMPS

SMPSRM

Features:

- Off-line operation from 180 V to 280 Vac mains.
- Fixed frequency and stand-by mode.
- Automatically changes operating mode based on load requirements.
- Precise limiting of maximum power in fixed frequency mode.

ON Semiconductor Advantages:

- Built-in protection circuitry for current limitation, overvoltage detection, foldback, demagnetization and softstart.
- Reduced frequency in stand-by mode.

Devices:

Part Number	Description
MC44603P	Enhanced Mixed Frequency Mode GreenLine™ PWM Controller
MTP6N60E	TMOS™ E-FET™ Power Field Effect Transistor (N-Channel)
MR856	Fast Recovery Rectifier (600 V)
MR852	Fast Recovery Rectifier (200 V)
TL431	Programmable Precision Reference
1N4733A	Zener Voltage Regulator Diode (5.1 V)
1N4007	General Purpose Rectifier (1000 V)

Application: Efficient Safety Circuit for Electronic Ballast

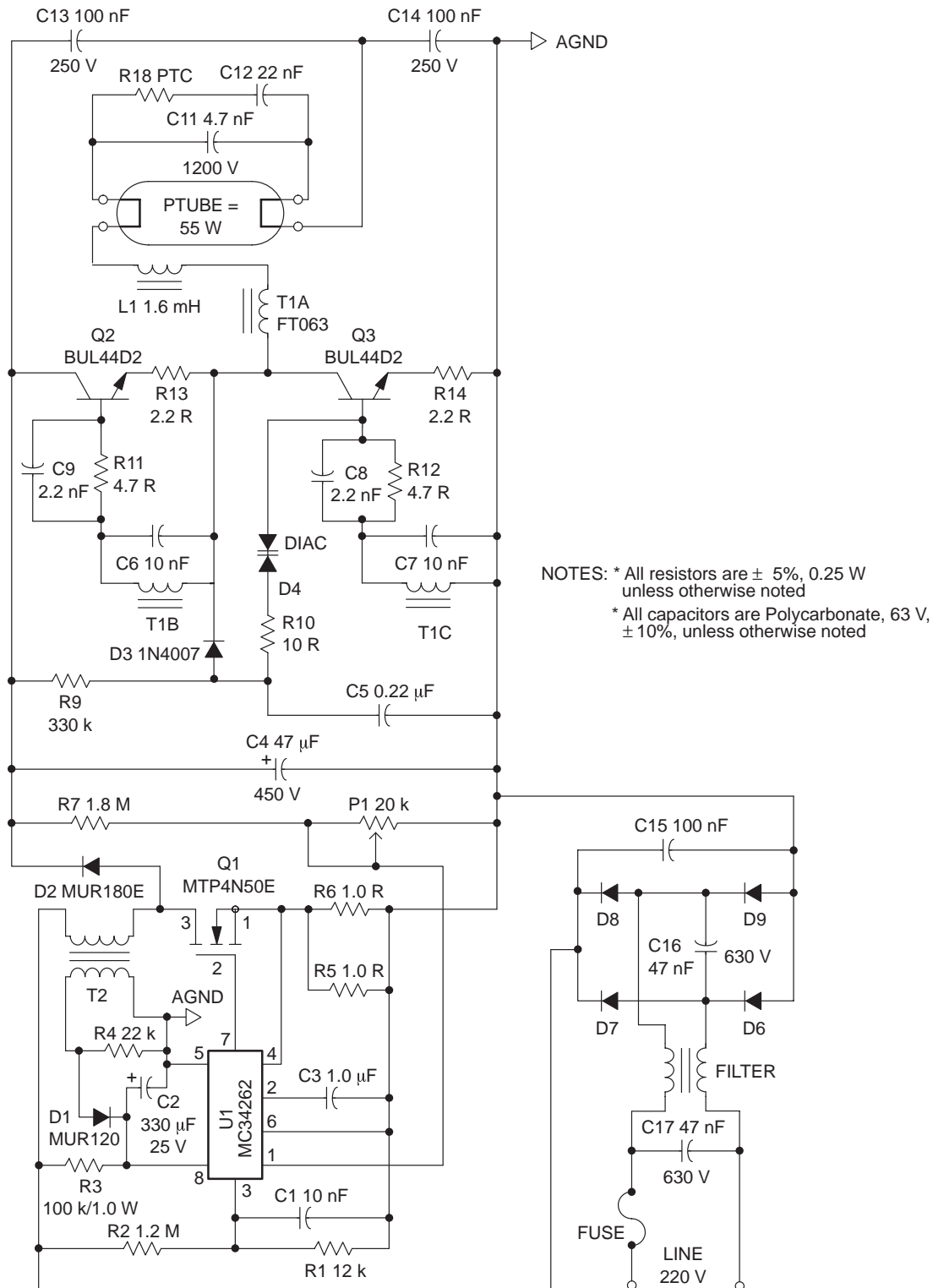

Figure 43. Efficient Safety Circuit for Electronic Ballast

SMPSRM

Features:

Easy to implement circuit to avoid thermal runaway when fluorescent lamp does not strike.

ON Semiconductor Advantages:

Power devices do not have to be oversized – lower cost solution.

Includes power factor correction.

Devices:

Part Number	Description
MC34262	Power Factor Controller
MTP4N50E	TMOS E-FET Power Field Effect Transistor (N-Channel)
MUR120	Ultrafast Rectifier (200 V)
BUL44D2	Bipolar Transistor* for Electronic Lamp Ballast (400 V)
1N4007	General Purpose Diode (1000 V)
1N5240B	Zener Voltage Regulator Diode (10 V)

*Other Lamp Ballast Options:

	1, 2 Lamps	3, 4 Lamps
825 V	BUL642D2 BUB642D2	BUL642D2 BUB642D2
100 V	MJD18002D2	MJB18004D2 MJE18004D2
1200 V	MJD18202D2	MJB18204D2 MJE18204D2

ON Semiconductor's H2BIP process integrates a diode and bipolar transistor for a single package solution.

Application: Lamp Ballast with Power Factor Correction (Evaluation Board)

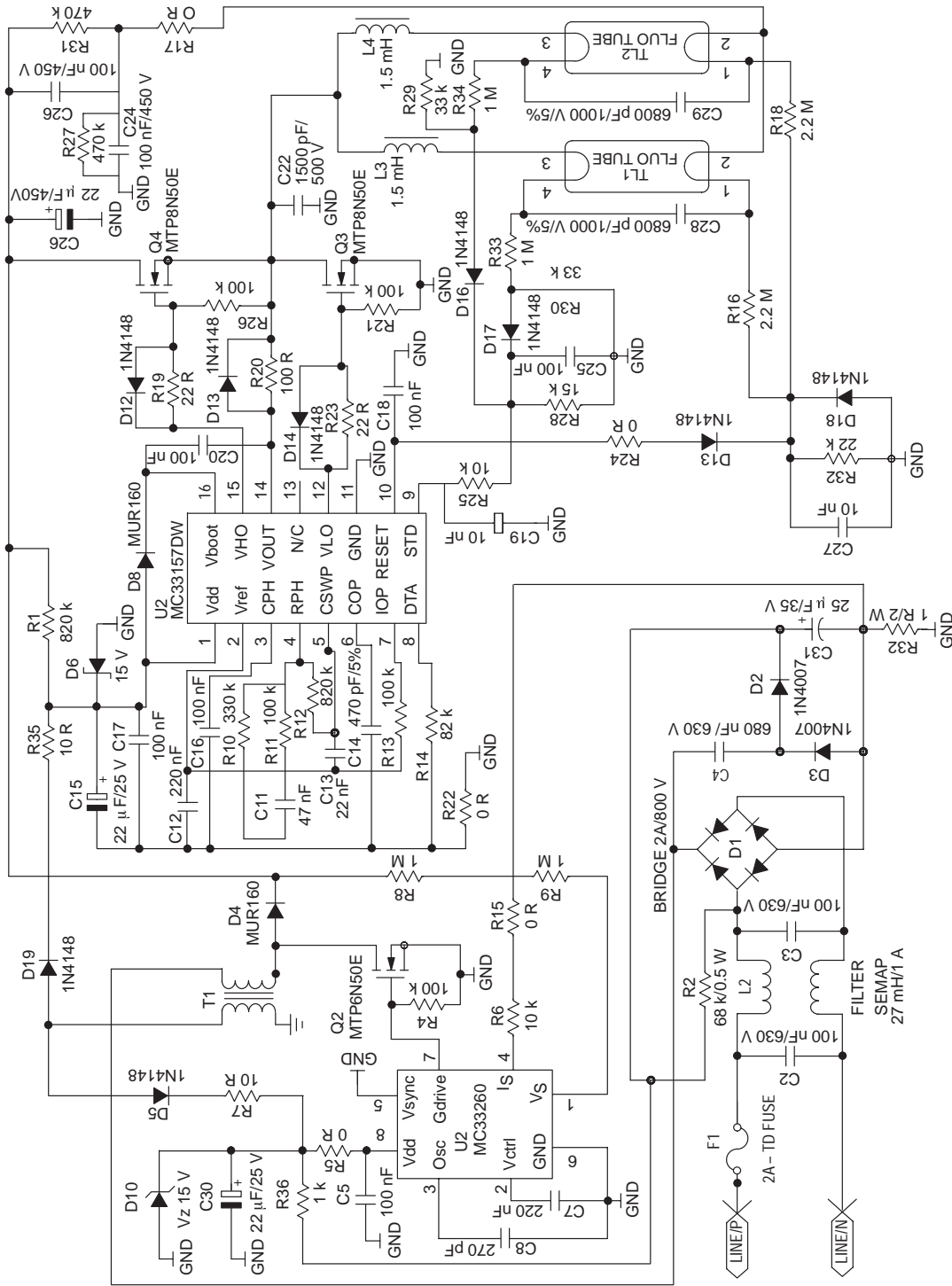

Figure 44. Lamp Ballast with Power Factor Correction (Evaluation Board)

SMPSRM

Features :

- Evaluation board includes all functions for an electronic ballast
- Includes power factor correction

ON Semiconductor advantages:

- Very low component count
- Built-in 2% voltage reference eliminates the need for external compensation over the temperature range
- Complete semiconductor solution

Devices:

Part Number	Description
MC33157DW	Electronic Ballast Controller
MC33260	Power Factor Controller
MTP8N50E	TMOS Power Field Effect Transistor (N-Channel)
MTP6N50E	TMOS Power Field Effect Transistor (N-Channel)
MUR160	Axial Lead Ultrafast Recovery Rectifier (600 V)
MUR460	Ultrafast Recovery Rectifier (600 V)
1N4007	General Purpose Rectifier (1000 V), 2 A/800 V Bridge

Application: AC–DC Battery Charger – Constant Current with Voltage Limit

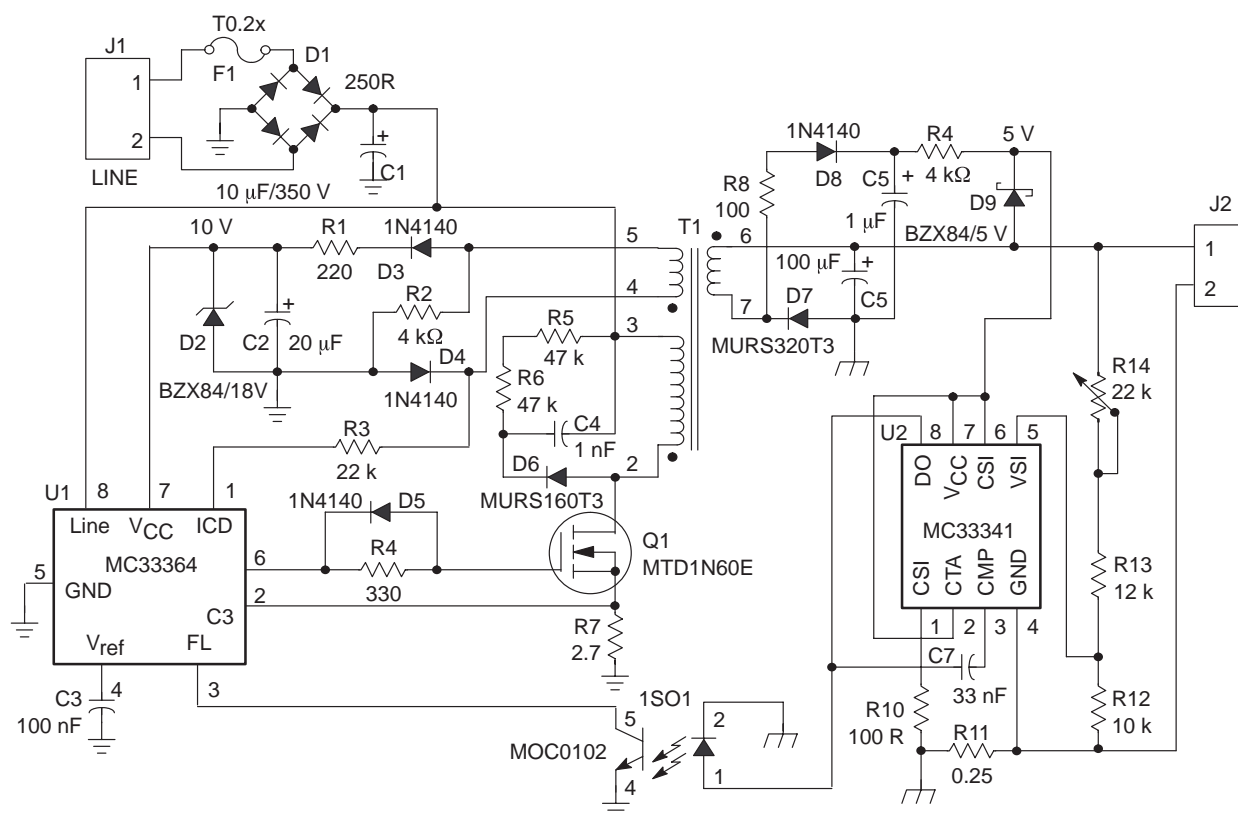

Figure 45. AC–DC Battery Charger – Constant Current with Voltage Limit

Features:

- Universal ac input.
- 9.5 Watt capability for charging portable equipment.
- Light weight.
- Space saving surface mount design.

ON Semiconductor Advantages:

- Off the shelf components
- SPICE model available for MC33341

Devices:

Part Number	Description
MC33341	Power Supply Battery Charger Regulator Control Circuit
MC33364	Critical Conduction SMPS Controller
MURS160T3	Surface Mount Ultrafast Rectifier (600 V)
MURS320T3	Surface Mount Ultrafast Rectifier (200 V)
MTD1N60E	TMOS™ Power MOSFET DPAK N–Channel (600 V)
BZX84C5V1LT1	Zener Voltage Regulator Diode (5.1 V)
BZX84/18V	Zener Voltage Regulator Diode (MMSZ18T1)
Transformer	For details consult AN1600

Literature Available from ON Semiconductor

Application Notes

These older Application Notes may contain part numbers that are no longer available, but the applications information may still be helpful in designing an SMPS. They are available through the Literature Distribution Center for ON Semiconductor at 800-344-3860 or 303-675-2175 or by email at ONlit@hibbertco.com. For international literature ordering information, see the second page or back cover of this book.

- AN873 – Understanding Power Transistor Dynamic Behavior: dv/dt Effects on Switching RBSOA
- AN875 – Power Transistor Safe Operating Area: Special Consideration for Switching Power Supplies
- AN913 – Designing with T MOS Power MOSFETs
- AN915 – Characterizing Collector-to-Emitter and Drain-to-Source Diodes for Switchmode Applications
- AN918 – Paralleling Power MOSFETs in Switching Applications
- AN920 – Theory and Applications of the MC34063 and μ A78S40 Switching Regulator Control Circuits
- AN929 – Insuring Reliable Performance from Power MOSFETs
- AN952 – Ultrafast Recovery Rectifiers Extend Power Transistor SOA
- AN1040 – Mounting Considerations for Power Semiconductors
- AN1043 – SPICE Model for T MOS Power MOSFETs
- AN1080 – External-Sync Power Supply with Universal Input Voltage Range for Monitors
- AN1083 – Basic Thermal Management of Power Semiconductors
- AN1090 – Understanding and Predicting Power MOSFET Switching Behavior
- AN1320 – 300 Watt, 100 kHz Converter Utilizes Economical Bipolar Planar Power Transistors

The following Application Notes are available directly from the ON Semiconductor website (<http://onsemi.com>).

- AN1327 – Very Wide Input Voltage Range, Off-line Flyback Switching Power Supply
- AN1520 – HDTMOS Power MOSFETs Excel in Synchronous Rectifier Applications
- AN1541 – Introduction to Insulated Gate Bipolar Transistor
- AN1542 – Active Inrush Current Limiting Using MOSFETs
- AN1543 – Electronic Lamp Ballast Design
- AN1547 – A DC to DC Converter for Notebook Computers Using HDTMOS and Synchronous Rectification
- AN1570 – Basic Semiconductor Thermal Measurement
- AN1576 – Reduce Compact Fluorescent Cost with Motorola's (ON Semiconductor) IGBTs for Lighting
- AN1577 – Motorola's (ON Semiconductor) D2 Series Transistors for Fluorescent Converters
- AN1593 – Low Cost 1.0 A Current Source for Battery Chargers
- AN1594 – Critical Conduction Mode, Flyback Switching Power Supply Using the MC33364
- AN1600 – AC-DC Battery Charger – Constant Current with Voltage Limit

Literature Available from ON Semiconductor (continued)

- AN1601 – Efficient Safety Circuit for Electronic Ballast
- AN1628 – Understanding Power Transistors Breakdown Parameters
- AN1631 – Using PSPICE to Analyze Performance of Power MOSFETs in Step–Down, Switching Regulators Employing Synchronous Rectification
- AN1669 – MC44603 in a 110 W Output SMPS Application
- AN1679 – How to Deal with Leakage Elements in Flyback Converters
- AN1680 – Design Considerations for Clamping Networks for Very High Voltage Monolithic Off–Line PWM Controllers
- AN1681 – How to Keep a Flyback Switch Mode Supply stable with a Critical–Mode Controller

Brochures and Data Books

Thermal Modeling & Management of Discrete Surface Mount Packages	BR1487/D
Analog/Interface ICs Device	DL128/D
Bipolar Device Data	DL111/D
IGBT Device Data	DL202/D
Thyristor Device Data	DL137/D
TMOS Power MOSFET Device Data	DL135/D
TVS/Zener Device Data	DL150/D
Rectifier Device Data	DL151/D
Master Components Selector Guide	SG388/D

Device Models

Device models for SMPS circuits (MC33363 and MC33365), power transistors, rectifiers and other discrete products are available through ON Semiconductor's website or by contacting your local sales office.

SMPSRM

Reference Books Relating to Switching Power Supply Design

Baliga, B. Jayant,

Power Semiconductor Devices, PWS Publishing Co., Boston, 1996. 624 pages.

Brown, Marty,

Practical Switching Power Supply Design, Academic Press, Harcourt Brace Jovanovich, 1990. 240 pages.

Brown, Marty

Power Supply Cookbook, EDN Series for Design Engineers, ON Semiconductor Series in Solid State Electronics, Butterworth–Heinmann, MA, 1994. 238 pages

Chrysiss, G. C.,

High Frequency Switching Power Supplies: Theory and Design, Second Edition, McGraw–Hill, 1989. 287 pages

Gottlieb, Irving M.,

Power Supplies, Switching Regulators, Inverters, and Converters, 2nd Edition, TAB Books, 1994. 479 pages.

Kassakian, John G., Martin F. Schlect, and George C. Verghese,

Principles of Power Electronics, Addison–Wesley, 1991. 738 pages.

Lee, Yim–Shu,

Computer–Aided Analysis and Design of Switch–Mode Power Supplies, Marcel Dekker, Inc., NY, 1993

Lenk, John D.,

Simplified Design of Switching Power Supplies, EDN Series for Design Engineers, Butterworth–Heinmann, MA, 1994. 221 pages.

McLyman, C. W. T.,

Designing Magnetic Components for High Frequency DC–DC Converters, KG Magnetics, San Marino, CA, 1993. 433 pages, 146 figures, 32 tables

Mitchell, Daniel,

Small–Signal MathCAD Design Aids, e/j Bloom Associates, 115 Duran Drive, San Rafael, Ca 94903–2317, 415–492–8443, 1992. Computer disk included.

Mohan, Ned, Tore M. Undeland, William P. Robbins,

Power Electronics: Converter, Applications and Design, 2nd Edition, Wiley, 1995. 802 pages

Paice, Derek A.,

Power Electronic Converter Harmonics, Multipulse Methods for Clean Power, IEEE Press, 1995. 224 pages.

Whittington, H. W.,

Switched Mode Power Supplies: Design and Construction, 2nd Edition, Wiley, 1996 224 pages.

Web Locations for Switching–Mode Power Supply Information

Ardem Associates (Dr. R. David Middlebrook)

<http://www.ardem.com/>

Applied Power Electronics Conference (APEC)

The power electronics conference for the practical aspects of power supplies.

<http://www.apec-conf.org/>

Dr. Vincent G. Bello's Home Page

SPICE simulation for switching–mode power supplies.

<http://www.SpiceSim.com/>

e/j BLOOM Associates

(Ed Bloom) Educational Materials & Services for Power Electronics.

<http://www.ejbloom.com/>

The Darnell Group

(Jeff Shepard) Contains an excellent list of power electronics websites, an extensive list of manufacturer's contact information and more.

<http://www.darnell.com/>

Switching–Mode Power Supply Design by Jerrold Foutz

An excellent location for switching mode power supply information and links to other sources.

<http://www.smpstech.com/>

Institute of Electrical and Electronics Engineers (IEEE)

<http://www.ieee.org/>

IEEE Power Electronics Society

<http://www.pels.org/pels.html>

Power Control and Intelligent Motion (PCIM)

Articles from present and past issues.

<http://www.pcim.com/>

Power Corner

Frank Greenhalgh's Power Corner in EDTN

<http://fgl.com/power1.htm>

Power Designers

<http://www.powerdesigners.com/>

Power Quality Assurance Magazine

Articles from present and past issues.

<http://powerquality.com/>

Power Sources Manufacturers Association

A trade organization for the power sources industry.

<http://www.pσμα.com/>

Quantum Power Labs

An excellent hypertext–linked glossary of power electronics terms.

<http://www.quantumpower.com/>

Ridley Engineering, Inc.

Dr. Ray Ridley

<http://www.ridleyengineering.com/>

SMPSRM

Web Locations for Switching–Mode Power Supply Information (continued)

Springtime Enterprises – Rudy Severns

Rudy Severns has over 40 years of experience in switching–mode power supply design and static power conversion for design engineers.

<http://www.rudyseverns.com/>

TESLAcO

Dr. Slobodan Cuk is both chairman of TESLAcO and head of the Caltech Power Electronics Group.

<http://www.teslaco.com/>

Venable Industries

<http://www.venableind.com/>

Virginia Power Electronics Center (VPEC)

<http://www.vpec.vt.edu>

Analog ICs for SWITCHMODE Power Supplies

A number of different analog circuits that can be used for designing switchmode power supplies are shown on the following pages. These circuits are the same as those in the Power Management and System Management sections of the ON Semiconductor Components Selector Guide. Circuits used specifically for the off-line controllers and power factor controllers are in the Power Management section. Additional circuits that are frequently used with a SMPS design (dc-dc converters, voltage references, voltage regulators, MOSFET/IGBT drivers and dedicated power management controllers) are included for reference purposes. Undervoltage and overvoltage supervisory circuits are in the System Management section.

Information about the discrete semiconductors that are shown in this brochure and other discrete products that may be required for a switching power supply can be found in the ON Semiconductor Components Selector Guide (SG388/D).

Power Management Circuits

In Brief . . .

In most electronic systems, some form of voltage regulation is required. In the past, the task of voltage regulator design was tediously accomplished with discrete devices, and the results were quite often complex and costly. Today, with bipolar monolithic regulators, this task has been significantly simplified. The designer now has a wide choice of fixed, low dropout and adjustable type voltage regulators. These devices incorporate many built-in protection features, making them virtually immune to the catastrophic failures encountered in older discrete designs.

The switching power supply continues to increase in popularity and is one of the fastest growing markets in the world of power conversion. They offer the designer several important advantages over linear series-pass regulators. These advantages include significant advancements in the areas of size and weight reduction, improved

	Page
DC-DC Converters with Inductor	59
Inductorless Charge Pump Voltage Converters	67
Off-Line SMPS Controllers	72
High Voltage Off-Line Switching Regulators	82
Power Factor Controllers	88
Voltage References	93
Linear Voltage Regulators	95
LDO Linear Voltage Regulators	103
Drivers	115
Dedicated Power Management Controllers	121
Supervisory ICs	125

efficiency, and the ability to perform voltage step-up, step-down, and voltage-inverting functions. ON Semiconductor offers a diverse portfolio of full featured switching regulator control circuits which meet the needs of today's modern compact electronic equipment.

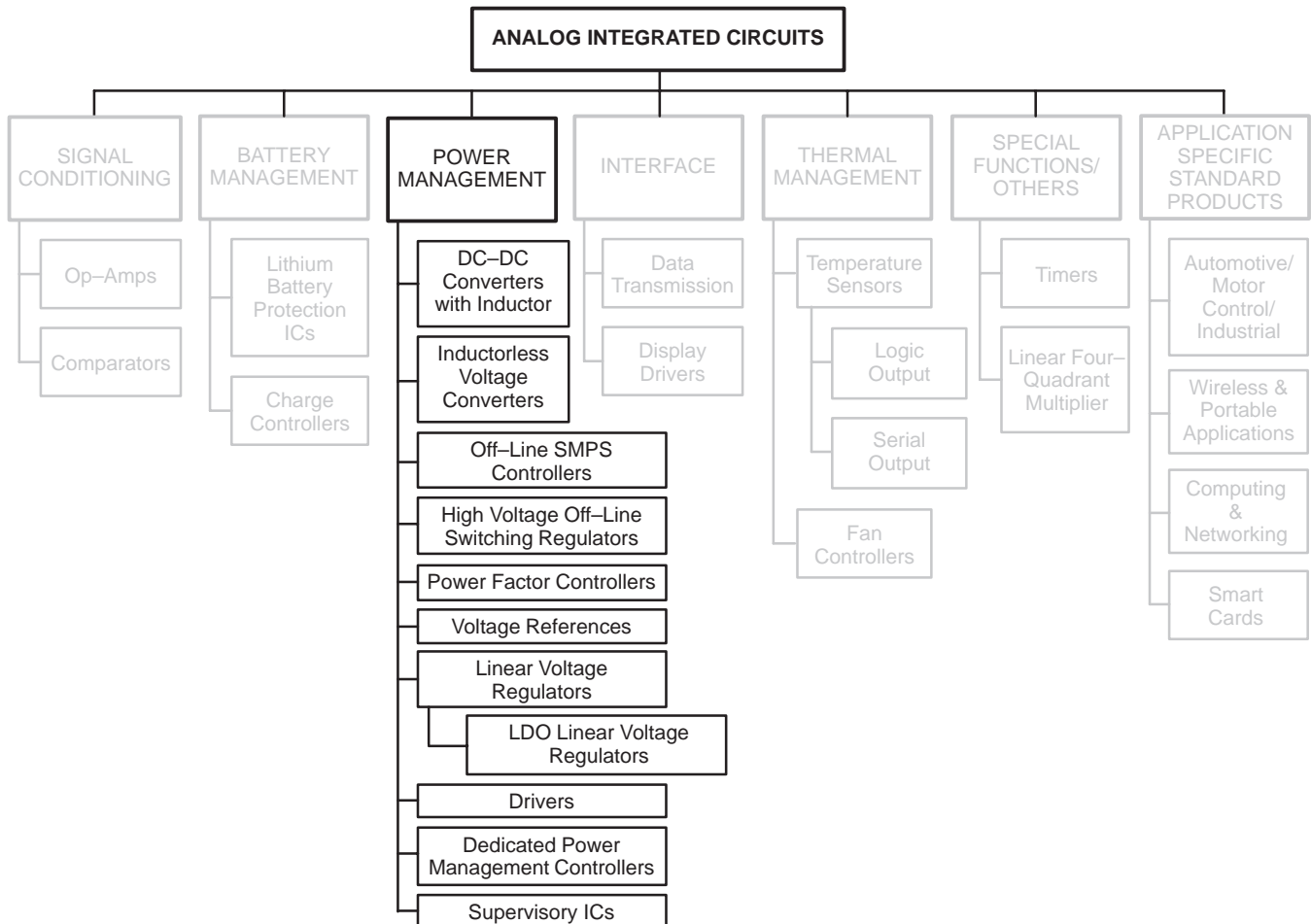

DC-DC Converters with Inductor

In Brief . . .

Available in multiple DIP and surface mount packages, DC-DC converters from ON Semiconductor cover a very wide range of output current levels from 50 mA up to 5 A and can be used in any topology, step-up, step-down, inverting and step-up and down.

These products are ideally suited to provide on-board conversion in systems where the power is distributed to various elements or electronic boards.

Recent developments have used synchronous rectification and CMOS technology for better efficiency and lower current consumption.

	Page
Single-Ended Controllers with On-Chip Power Switch	61
Easy Switcher™ Single-Ended Controllers with On-Chip Power Switch	61
CMOS Micropower DC-to-DC Converters	63

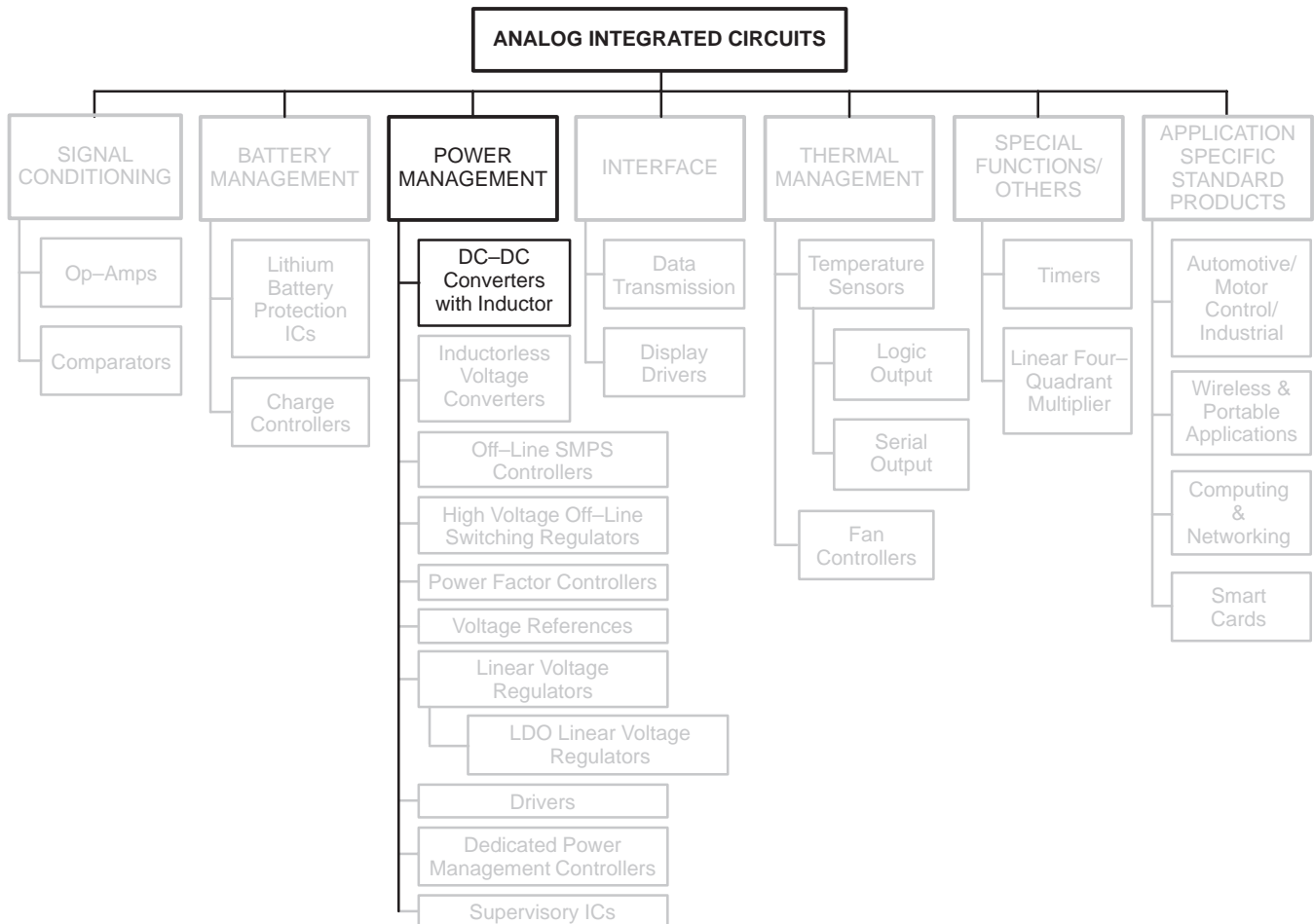

SMPSRM

Device	Input Voltage Range (V)	Output Voltage (V)	Output Switch Current (A)	Control Scheme	Topology	Package	Temp. Range (°C)	Features
μA78S40	2.5 to 40	Adjustable	1.5	PFM	Step-Up/Down & Inverting	DIP-16	0 to 70, -40 to +85	Internal Switch Transistor
MC34063A	3.0 to 40	Adjustable	1.5	PFM	Step-Up/Down & Inverting	DIP-8/SO-8	0 to 70, -40 to +85	Internal Switch Transistor
MC34163	2.5 to 40	Adjustable	3.0	PFM	Step-Up/Down & Inverting	DIP-16/SO-16	0 to 70, -40 to +85	Internal Switch Transistor
MC34166	7.5 to 40	Adjustable	3.0	PWM	Step-Up/Down & Inverting	5 Pin TO-220, 5 Pin D2PAK	0 to 70, -40 to +85	Internal Switch Transistor
MC34167	7.5 to 40	Adjustable	5.0	PWM	Step-Up/Down & Inverting	5 Pin TO-220, 5 Pin D2PAK	0 to 70, -40 to +85	Internal Switch Transistor
LM2574	4.75 to 45	3.3, 5, 12, 15 & Adjust.	0.5	PWM	Step-Down	DIP-8, SO-16WB	-40 to +125	Internal Switch Transistor, On/Off Control
LM2575	4.75 to 45	3.3, 5, 12, 15 & Adjust.	1.0	PWM	Step-Down	5 Pin TO-220, 5 Pin D2PAK	-40 to +125	Internal Switch Transistor, On/Off Control
LM2576	4.75 to 45	3.3, 5, 12, 15 & Adjust.	3.0	PWM	Step-Down	5 Pin TO-220, 5 Pin D2PAK	-40 to +125	Internal Switch Transistor, On/Off Control
MC33463-K	0.9 to Vout	3, 3.3, 5	0.250	VFM	Step-Up	SOT-89	-30 to +80	Internal Switch Transistor
MC33463-L	0.9 to Vout	3, 3.3, 5	0.050	VFM	Step-Up	SOT-89	-30 to +80	External Switch Transistor
MC33466-J	0.9 to Vout	3, 3.3, 5	0.250	PWM	Step-Up	SOT-89	-30 to +80	Internal Switch Transistor
MC33466-L	0.9 to Vout	3, 3.3, 5	0.050	PWM	Step-Up	SOT-89	-30 to +80	External Switch Transistor

PWM: Pulse Width Modulation PFM: Pulse Frequency Modulation VFM: Variable Frequency Modulation

Table 1. Single-Ended Controllers with On-Chip Power Switch

These monolithic power switching regulators contain all the active functions required to implement standard dc-to-dc converter configurations with a minimum number of external components.

I_O (mA) Max	Minimum Operating Voltage Range (V)	Operating Mode	Reference (V)	Maximum Useful Oscillator Frequency (kHz)	Device	T_A (°C)	Package
1500 (Uncommitted Power Switch)	2.5 to 40	Voltage	$1.25 \pm 5.2\%$ (1)	100	$\mu A78S40$	0 to +70	DIP-16
						-40 to +85	
			$1.25 \pm 2.0\%$		MC34063A	0 to +70	DIP-8
						SO-8	
			MC33063A		-40 to +85	DIP-8	
					-40 to +125	SO-8	
3400 (Uncommitted Power Switch)	2.5 to 40	Voltage	$1.25 \pm 2.0\%$ and $5.05 \pm 3.0\%$	100	MC34163	0 to +70	DIP-16, SO-16L
					MC33163	-40 to +85	
3400(2) (Dedicated Emitter Power Switch)	7.5 to 40		$5.05 \pm 2.0\%$	72 \pm 12% Internally Fixed	MC34166	0 to +70	5-Pin D ² PAK, 5-Pin TO-220
					MC33166	-40 to +85	
5500(3) (Dedicated Emitter Power Switch)					MC34167	0 to +70	
					MC33167	-40 to +85	

(1) Tolerance applies over the specified operating temperature range.

(2) Guaranteed minimum, typically 4300 mA.

(3) Guaranteed minimum, typically 6500 mA.

Table 2. Easy Switcher™ Single-Ended Controllers with On-Chip Power Switch

The Easy Switcher™ series is ideally suited for easy, convenient design of a step-down switching regulator (buck converter), with a minimum number of external components.

I_O (mA) Max	Minimum Operating Voltage Range (V)	Operating Mode	Oscillator Frequency (kHz)	Output Voltage (V)	Device	T_J (°C)	Package
500	4.75 to 40	Voltage	52 Fixed Internal	3.3	LM2574N-3.3	-40 to +125	DIP-8
	8.0 to 40			5.0	LM2574N-5		
	15 to 40			12	LM2574N-12		
	18 to 40			15	LM2574N-15		
	8.0 to 40			1.23 to 37	LM2574N-ADJ		

SMPSRM

Table 2. Easy Switcher™ Single-Ended Controllers with On-Chip Power Switch(continued)

The Easy Switcher™ series is ideally suited for easy, convenient design of a step-down switching regulator (buck converter), with a minimum number of external components.

I _O (mA) Max	Minimum Operating Voltage Range (V)	Operating Mode	Oscillator Frequency (kHz)	Output Voltage (V)	Device	T _J (°C)	Package
1000	4.75 to 40 8.0 to 40 15 to 40 18 to 40 8.0 to 40	Voltage	52 Fixed Internal	3.3 5.0 12 15 1.23 to 37	LM2575T-3.3 LM2575T-5 LM2575T-12 LM2575T-15 LM2575T-ADJ	-40 to +125	5-Pin TO-220
	4.75 to 40 8.0 to 40 15 to 40 18 to 40 8.0 to 40			3.3 5.0 12 15 1.23 to 37	LM2575TV-3.3 LM2575TV-5 LM2575TV-12 LM2575TV-15 LM2575TV-ADJ		5-Pin TO-220
	4.75 to 40 8.0 to 40 15 to 40 18 to 40 8.0 to 40			3.3 5.0 12 15 1.23 to 37	LM2575D2T-3.3 LM2575D2T-5 LM2575D2T-12 LM2575D2T-15 LM2575D2T-ADJ		5-Pin D ² PAK
3000	4.75 to 40 8.0 to 40 15 to 40 18 to 40 8.0 to 40	Voltage	52 Fixed Internal	3.3 5.0 12 15 1.23 to 37	LM2576T-3.3 LM2576T-5 LM2576T-12 LM2576T-15 LM2576T-ADJ	-40 to +125	5-Pin TO-220
	4.75 to 40 8.0 to 40 15 to 40 18 to 40 8.0 to 40			3.3 5.0 12 15 1.23 to 37	LM2576TV-3.3 LM2576TV-5 LM2576TV-12 LM2576TV-15 LM2576TV-ADJ		5-Pin TO-220
	4.75 to 40 8.0 to 40 15 to 40 18 to 40 8.0 to 40			3.3 5.0 12 15 1.23 to 37	LM2576D2T-3.3 LM2576D2T-5 LM2576D2T-12 LM2576D2T-15 LM2576D2T-ADJ		5-Pin D ² PAK

Switching Regulator Control Circuits (continued)

CMOS Micropower DC-to-DC Converters

Variable Frequency Micropower DC-to-DC Converter

MC33463H

T_A = -30° to +80°C, SOT-89

The MC33463 series are micropower step-up switching voltage regulators, specifically designed for handheld and laptop applications, to provide regulated output voltages using a minimum of external parts. A wide choice of output voltages are available. These devices feature a very low quiescent bias current of 4.0 μA typical.

The MC33463H-XXKT1 series features a highly accurate voltage reference, an oscillator, a variable frequency modulation (VFM) controller, a driver transistor (Lx), a comparator and feedback resistive divider.

The MC33463H-XXLT1 is identical to the MC33463H-XXKT1, except that a drive pin (EXT) for an external transistor is provided.

Due to the low bias current specifications, these devices are ideally suited for battery powered computer, consumer, and industrial equipment where an extension of useful battery life is desirable.

MC33463 Series Features:

- Low Quiescent Bias Current of 4.0 μA
- High Output Voltage Accuracy of ±2.5%
- Low Startup Voltage of 0.9 V at 1.0 mA
- Wide Output Voltage Range of 2.5 V to 7.5 V Available
- High Efficiency of 80% Typical
- Surface Mount Package

ORDERING INFORMATION

Device	Output Voltage	Type	Operating Temperature Range	Package (Tape/Reel)
MC33463H-30KT1 MC33463H-33KT1 MC33463H-50KT1	3.0 3.3 5.0	Int. Switch	T _A = -30° to +80°C	SOT-89 (Tape)
MC33463H-30LT1 MC33463H-33LT1 MC33463H-50LT1	3.0 3.3 5.0	Ext. Switch Drive		SOT-89 (Tape)

Other voltages from 2.5 V to 7.5 V, in 0.1 V increments are available. Consult factory for information.

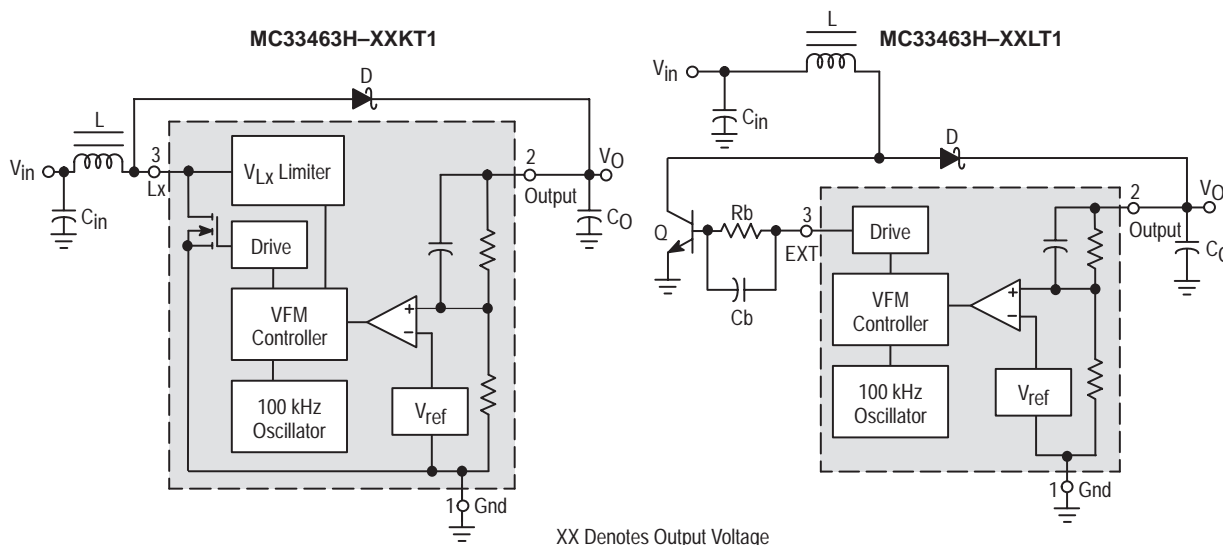

SMPSRM

CMOS Micropower DC-to-DC Converters (continued)

Fixed Frequency PWM Micropower DC-to-DC Converter

MC33466H

$T_A = -30^\circ$ to $+80^\circ\text{C}$, SOT-89

The MC33466 series are micropower switching voltage regulators, specifically designed for handheld and laptop applications, to provide regulated output voltages using a minimum of external parts. A wide choice of output voltages are available. These devices feature a very low quiescent bias current of $15\ \mu\text{A}$ typical.

The MC33466H-XXJT1 series features a highly accurate voltage reference, an oscillator, a pulse width modulation (PWM) controller, a driver transistor (Lx), an error amplifier and feedback resistive divider.

The MC33466H-XXLT1 is identical to the MC33466H-XXJT1, except that a drive pin (EXT) for an

external transistor is provided.

Due to the low bias current specifications, these devices are ideally suited for battery powered computer, consumer, and industrial equipment where an extension of useful battery life is desirable.

MC33466 Series Features:

- Low Quiescent Bias Current of $15\ \mu\text{A}$
- High Output Voltage Accuracy of $\pm 2.5\%$
- Low Startup Voltage of $0.9\ \text{V}$ at $1.0\ \text{mA}$
- Soft-Start = $500\ \mu\text{s}$
- Surface Mount Package

ORDERING INFORMATION

Device	Output Voltage	Type	Operating Temperature Range	Package (Tape/Reel)
MC33466H-30JT1	3.0	Int.	$T_A = -30^\circ$ to $+80^\circ\text{C}$	SOT-89 (Tape)
MC33466H-33JT1	3.3	Switch		
MC33466H-50JT1	5.0			
MC33466H-30LT1	3.0	Ext.		SOT-89 (Tape)
MC33466H-33LT1	3.3	Switch		
MC33466H-50LT1	5.0	Drive		

Other voltages from 2.5 V to 7.5 V, in 0.1 V increments are available. Consult factory for information.

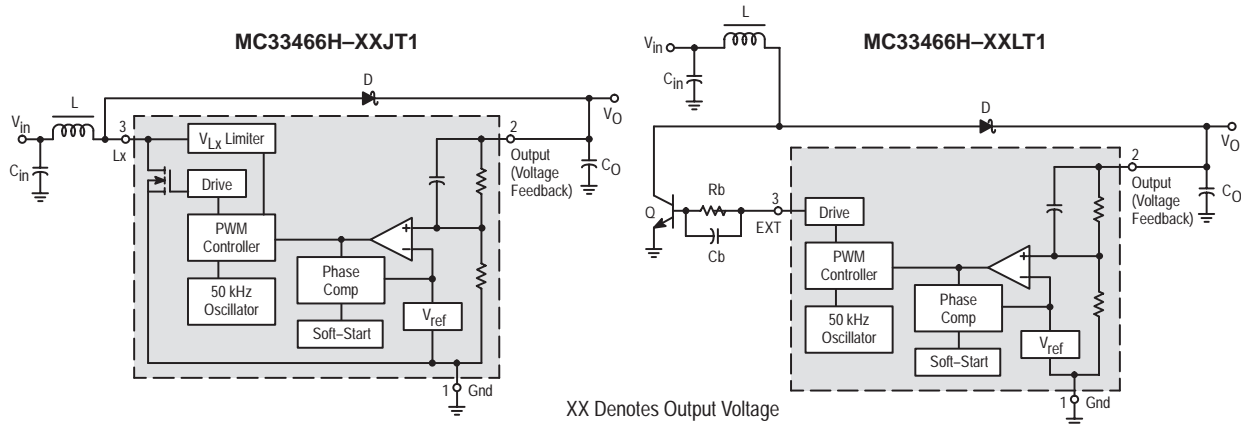

Switching Regulator Control Circuits (continued)

Easy Switcher™ Single-Ended Controllers with On-Chip Power Switch
Step-Down Voltage Regulators

LM2574N-XX

T_J = -40° to +125°C, DIP-8

The LM2574 series of regulators are monolithic integrated circuits ideally suited for easy and convenient design of a step-down switching regulator (buck converter). All circuits of this series are capable of driving a **0.5 A** load with excellent line and load regulation. These devices are available in fixed output voltages of 3.3 V, 5.0 V, 12 V, 15 V, and an adjustable output version.

These regulators were designed to minimize the number of external components to simplify the power supply design. Standard series of inductors optimized for use with the LM2574 are offered by several different inductor manufacturers.

Since the LM2574 converter is a switch-mode power supply, its efficiency is significantly higher in comparison with popular three-terminal linear regulators, especially with higher input voltages. In most cases, the power dissipated by the LM2574 regulator is so low, that the copper traces on the printed circuit board are normally the only heatsink needed and no additional heatsinking is required.

The LM2574 features include a guaranteed ±4% tolerance on output voltage within specified input voltages and output load conditions, and ±10% on the oscillator frequency (±2% over 0°C to +125°C). External shutdown is included, featuring 60 µA (typical) standby current. The output switch includes cycle-by-cycle

current limiting, as well as thermal shutdown for full protection under fault conditions.

Features

- 3.3 V, 5.0 V, 12 V, 15 V, and Adjustable Output Versions
- Adjustable Version Output Voltage Range, 1.23 to 37 V ±4% max over Line and Load Conditions
- Guaranteed **0.5 A** Output Current
- Wide Input Voltage Range: 4.75 to 40 V
- Requires Only 4 External Components
- 52 kHz Fixed Frequency Internal Oscillator
- TTL Shutdown Capability, Low Power Standby Mode
- High Efficiency
- Uses Readily Available Standard Inductors
- Thermal Shutdown and Current Limit Protection

Applications

- Simple and High-Efficiency Step-Down (Buck) Regulators
- Efficient Pre-Regulator for Linear Regulators
- On-Card Switching Regulators
- Positive to Negative Converters (Buck-Boost)
- Negative Step-Up Converters
- Power Supply for Battery Chargers

XX = Voltage Option, i.e., 3.3, 5, 12, 15 V; and ADJ for Adjustable Output

Representative Block Diagram and Typical Application

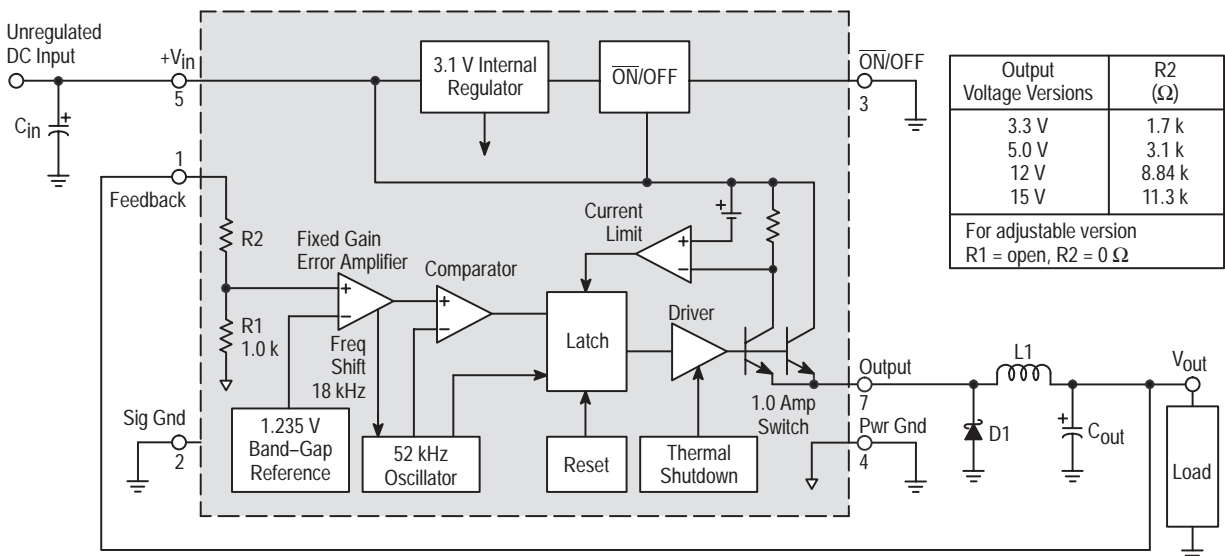

SMPSRM

Step-Down Voltage Regulators (continued)

LM2575T-XX, TV, D2T, LM2576T-XX, TV, D2T

$T_J = -40^\circ$ to $+125^\circ\text{C}$, TO-220 5 Leads, D²PAK 5 Leads

The LM2575/6 series of regulators are monolithic integrated circuits ideally suited for easy and convenient design of a step-down switching regulator (buck converter). All circuits of this series are capable of driving a **1.0 A** (LM2575) or **3.0 A** (LM2576) load with excellent line and load regulation. These devices are available in fixed output voltages of 3.3 V, 5.0 V, 12 V, 15 V, and an adjustable output version.

These regulators were designed to minimize the number of external components to simplify the power supply design. Standard series of inductors optimized for use with the LM2575/6 are offered by several different inductor manufacturers.

Since the LM2575/6 converter is a switch-mode power supply, its efficiency is significantly higher in comparison with popular three-terminal linear regulators, especially with higher input voltages. In many cases, the power dissipated by the LM2575/6 regulator is so low, that no heatsink is required or its size could be reduced dramatically.

The LM2575/6 features include a guaranteed $\pm 4\%$ tolerance on output voltage within specified input voltages and output load conditions, and $\pm 10\%$ on the oscillator frequency ($\pm 2\%$ over 0°C to 125°C). External shutdown is included, featuring $80\ \mu\text{A}$ typical standby current. The output switch includes cycle-by-cycle current limiting, as well as thermal shutdown for full protection under fault conditions.

Features

- 3.3 V, 5.0 V, 12 V, 15 V, and Adjustable Output Versions
- Adjustable Version Output Voltage Range of 1.23 V to 37 V $\pm 4\%$ Maximum Over Line and Load Conditions
- Guaranteed **1.0 A** (LM2575) **3.0 A** (LM2576) Output Current
- Wide Input Voltage Range: 4.75 V to 40 V
- Requires Only 4 External Components
- 52 kHz Fixed Frequency Internal Oscillator
- TTL Shutdown Capability, Low Power Standby Mode
- High Efficiency
- Uses Readily Available Standard Inductors
- Thermal Shutdown and Current Limit Protection

Applications

- Simple and High-Efficiency Step-Down (Buck) Regulators
- Efficient Pre-Regulator for Linear Regulators
- On-Card Switching Regulators
- Positive to Negative Converters (Buck-Boost)
- Negative Step-Up Converters
- Power Supply for Battery Chargers

XX = Voltage Option, i.e., 3.3, 5, 12, 15 V; and ADJ for adjustable Output

Representative Block Diagram and Typical Application

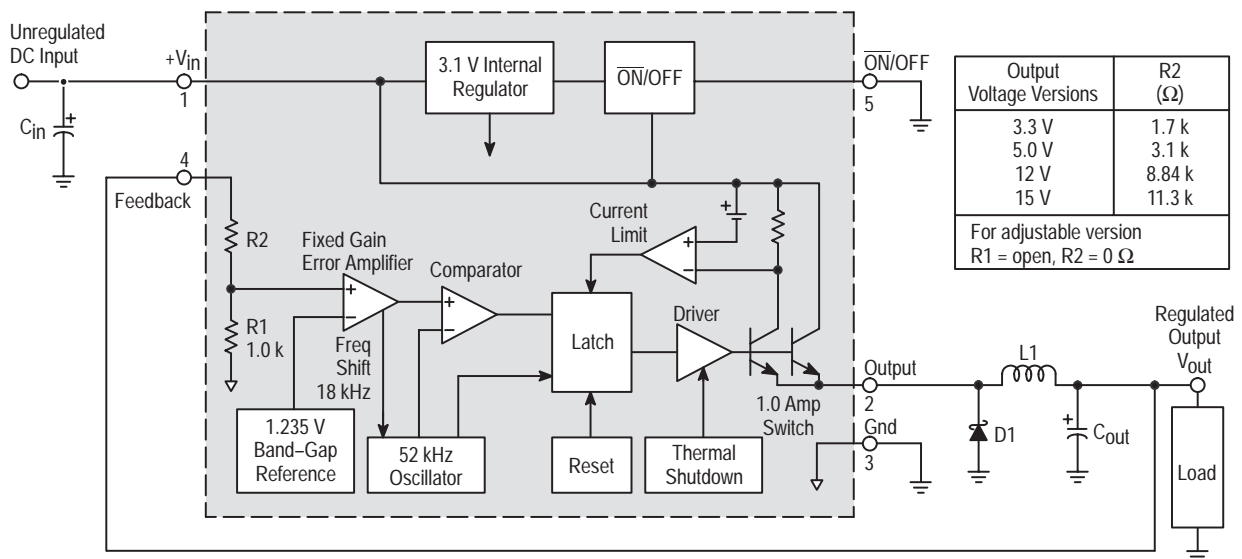

This device contains 162 active transistors.

Inductorless Charge Pump Voltage Converters

In Brief . . .

ON Semiconductor charge pump converters do not require inductors, saving associated cost, size, and EMI. Using as few as two inexpensive external capacitors, these devices feature wide input voltage ranges and high operating efficiencies.

	Page
Charge Pump Converters	68
Charge Pump DC-to-DC Voltage Converters	69
Switched Capacitor Voltage Converters	70
100mA Charge Pump Voltage Converter with Shutdown	71

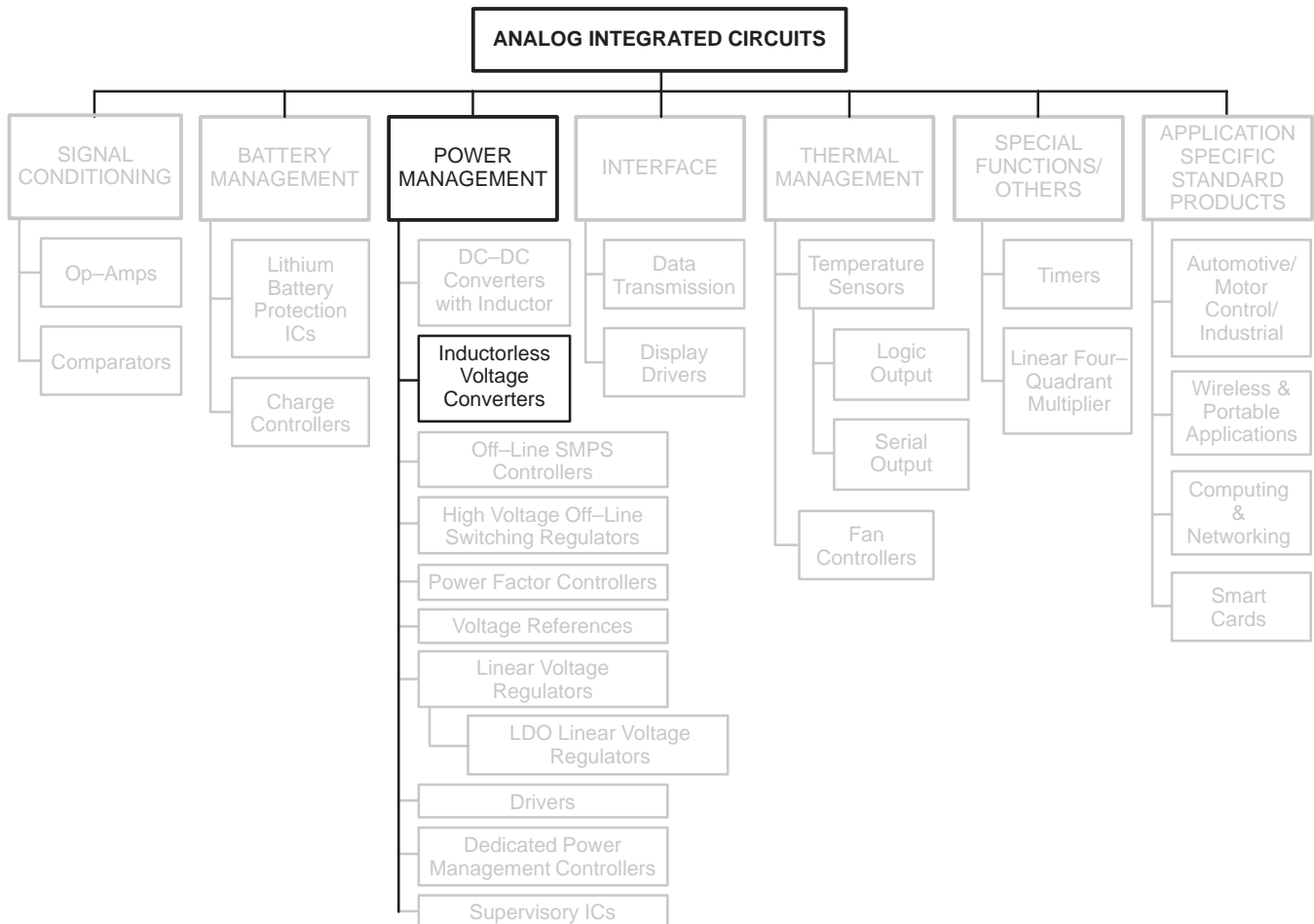

SMPSRM**Charge Pump Converters**

Part #	Output Voltage	Input Voltage Range (V)	Quiescent Supply Current* (Max μA @ 25°C)	Output Current (Typ. mA)	Package Options	Features
MC1121	$V_{\text{OUT}} = -V_{\text{IN}}$ or $V_{\text{OUT}} = 2 V_{\text{IN}}$	1.5 to 5.5	500	100	DIP-8, MSOP-8, SO-8	100 mA Output, MSOP Package, Low Power Shutdown Mode
MC7660	$V_{\text{OUT}} = -V_{\text{IN}}$ or $V_{\text{OUT}} = 2 V_{\text{IN}}$	1.5 to 10	180	20	DIP-8, SO-8	—
MAX828	$V_{\text{OUT}} = -V_{\text{IN}}$ or $V_{\text{OUT}} = 2 V_{\text{IN}}$	1.5 to 5.5	90	25	SOT-23A-5	SOT-23-5 Package, 12 kHz Oscillator
MAX829	$V_{\text{OUT}} = -V_{\text{IN}}$ or $V_{\text{OUT}} = 2 V_{\text{IN}}$	1.5 to 5.5	260	25	SOT-23A-5	SOT-23-5 Package, 35 kHz Oscillator

NOTE: *Measured at $V_{\text{DD}} = 5.0 \text{ V}$ at 25°C and no load.

Charge Pump Converters (continued)

Charge Pump DC-to-DC Voltage Converter

MC7660

$T_A = -40^\circ$ to $+85^\circ\text{C}$, SO-8, DIP-8

The MC7660 is a pin-compatible replacement for the Industry standard ICL7660 charge pump voltage converter. It converts a +1.5V to +10V input to a corresponding -1.5V to -10V output using only two low-cost capacitors, eliminating inductors and their associated cost, size and EMI.

The on-board oscillator operates at a nominal frequency of 10kHz. Operation below 10kHz (for lower supply current applications) is possible by connecting an external capacitor from OSC to ground (with pin 1 open).

The MC7660 is available in an 8-pin SOIC and DIP package in extended temperature range.

Features

- Converts +5V Supply to -5V Supply
- Wide Input Voltage Range: 1.5V to 10V
- Efficient Voltage Conversion: 99.9%
- Excellent Power Efficiency: 98%
- Low Power Supply: $80\mu\text{A}$ @ 5V_{IN}
- Low Cost and Easy to Use
 - Only Two External Capacitors Required
- Available in Small Outline (SO) Package
- ESD Protection: $\geq 2.5\text{kV}$
- No Dx Diode Required for High Voltage Operation

Applications

- RS-232 Negative Bias
- Display Bias
- Data Acquisition Negative Supply Generation

ORDERING INFORMATION

Device	Operating Temperature Range	Package
MC7660DR2	$T_A = -40^\circ$ to $+85^\circ\text{C}$	SO-8, DIP-8

Functional Block Diagram

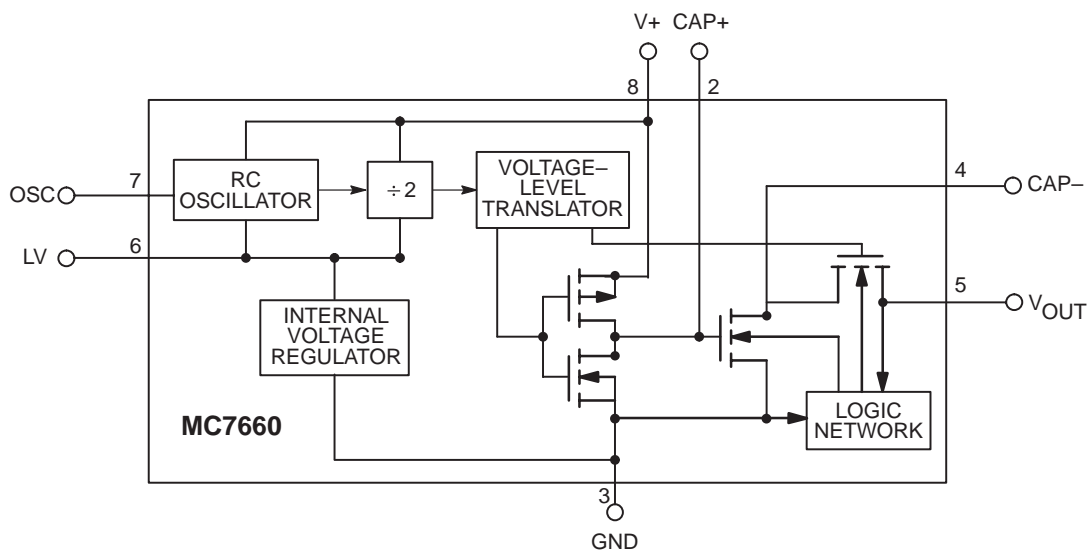

SMPSRM

Charge Pump Converters (continued)

Switched Capacitor Voltage Converters

MAX828/MAX829

$T_A = -40^\circ$ to $+85^\circ\text{C}$, SOT-23-5

The MAX828/829 are CMOS “charge-pump” voltage converters in ultra-small SOT-23 5 lead packages. They invert and/or double an input voltage which can range from +1.5V to +5.5V. Conversion efficiency is typically >95%. Switching frequency is 12kHz for the MAX828 and 35kHz for the MAX829.

External component requirement is only two capacitors (3.3 μF nominal) for standard voltage inverter applications. With a few additional components a positive doubler can also be built. All other circuitry, including control, oscillator, power MOSFETs are integrated on-chip. Supply current is 50 μA (MAX828) and 115 μA (MAX829).

The MAX828 and MAX829 are available in a SOT-23 5 lead surface mount package.

Features

- Charge Pump in SOT-23 5 Lead Package
- >95% Voltage Conversion Efficiency
- Voltage Inversion and/or Doubling
- Low 50 μA (MAX828) Quiescent Current
- Operates from +1.5V to +5.5V
- Up to 25 mA Output Current
- Only Two External Capacitors Required
- Tested Operating Temperature Range: -40°C to $+85^\circ\text{C}$

Applications

- LCD Panel Bias
- Cellular Phones
- Pagers
- PDAs, Portable Dataloggers
- Battery-Powered Devices

ORDERING INFORMATION

Device	Operating Temperature Range	Package
MAX828SNTR	$T_A = -40^\circ$ to $+85^\circ\text{C}$	SOT-23-5
MAX829SNTR		

Charge Pump Converters (continued)

100mA Charge Pump Voltage Converter with Shutdown

MC1121

$T_A = -40^\circ$ to $+85^\circ\text{C}$, Micro8

The MC1121 is a charge pump converter with 100mA output current capability. It converts a 2.4V to 5.5V input to a corresponding negative output voltage. As with all charge pump converters, the MC1121 uses no inductors saving cost, size, and reducing EMI.

An on-board oscillator operates at a typical frequency of 10kHz (at $V_{DD} = 5\text{V}$) when the frequency control input (FC) is connected to ground. The oscillator frequency increases to 200kHz when FC is connected to V_{DD} , allowing the use of smaller capacitors. Operation at sub-10kHz frequencies results in lower quiescent current and is accomplished with the addition of an external capacitor from OSC (pin 7) to ground. The MC1121 can be driven from an external clock connected OSC. Typical supply current at 10kHz is $50\mu\text{A}$, and falls to less than $1\mu\text{A}$ when the shutdown input is brought low, whether the internal or an external clock is used. The MC1121 is available in a Micro-8 package.

Features

- Converts a 2.4V to 5.5V Input Voltage to a Corresponding Negative Output Voltage (Inverter Mode)
- Uses Only 2 Capacitors; No Inductors Required!
- High Output Current: 100mA
- Selectable Oscillator Frequency: 10kHz to 200kHz
- Power-Saving Shutdown Input
- Optional High-Frequency Operation Allows Use of Small Capacitors
- Low Operating Current (FC = GND): $50\mu\text{A}$
- Tested Operating Temperature Range: -40°C to $+85^\circ\text{C}$

Applications

- Laptop Computers
- Medical Instruments
- Disk Drives
- μP -Based Controllers
- Process Instrumentation

ORDERING INFORMATION

Device	Operating Temperature Range	Package
MC1121DMR2	$T_A = -40^\circ$ to $+85^\circ\text{C}$	Micro8

Functional Block Diagram

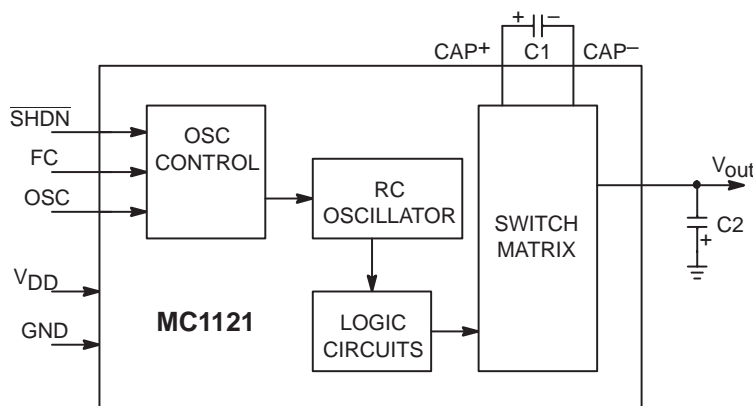

Off-line SMPS Controllers

In Brief . . .

These high performance controllers are optimized for off-line, ac-to-dc power supplies and dc-to-dc converters in the flyback topology. They also have undervoltage lockout voltages which are optimized for off-line and lower voltage dc-to-dc converters, respectively. Applications include desktop computers, peripherals, televisions, games, and various consumer appliances.

	Page
Off-line SMPS Controllers	73
Special Switching Regulator Controllers	76

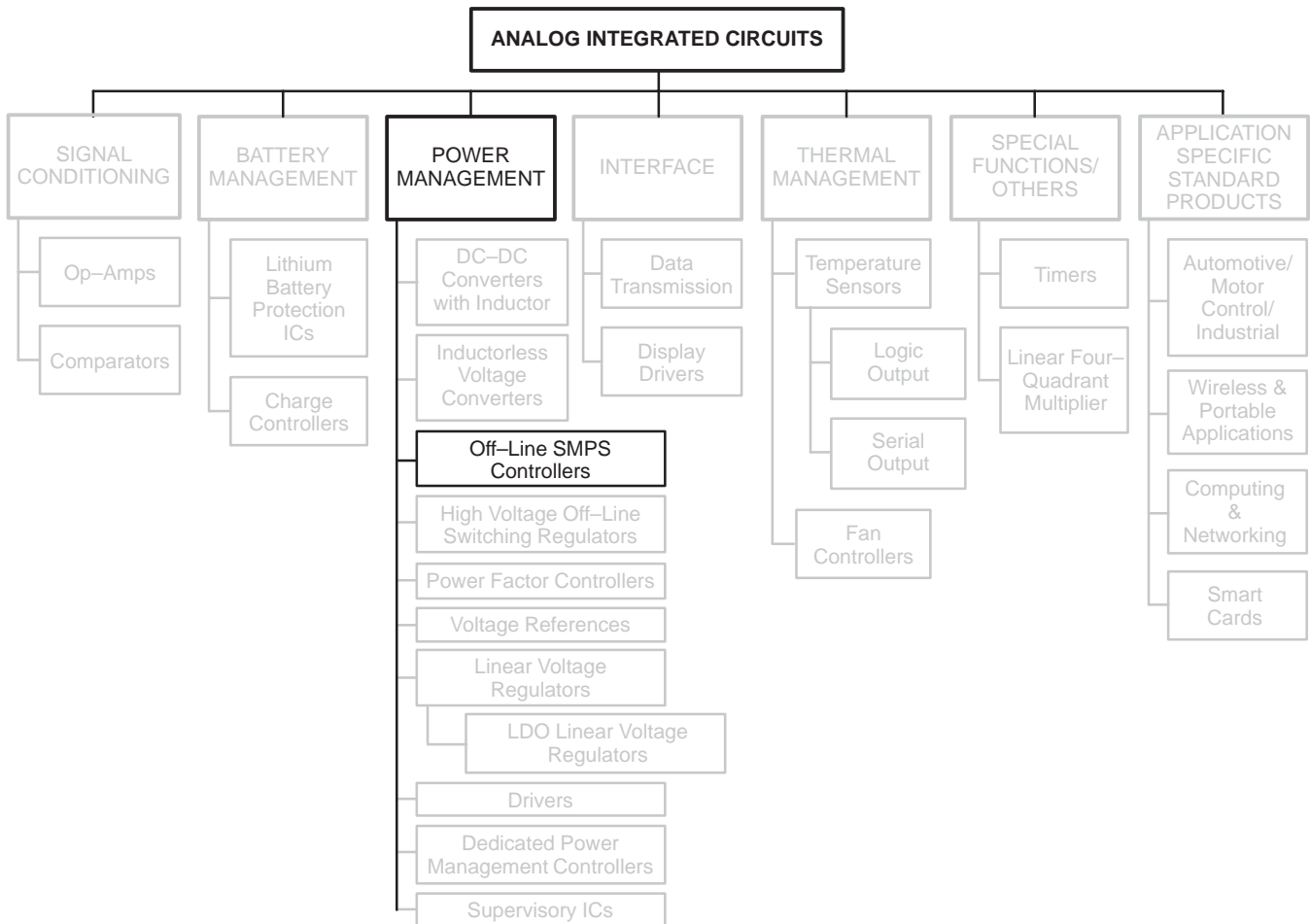

Off-line SMPS Controllers

These devices contain the primary building blocks which are required to implement a variety of switching power supplies. The product offerings fall into three major categories consisting of single-ended and double-ended controllers, plus single-ended ICs with on-chip power switch transistors. These circuits operate

in voltage, current or resonant modes and are designed to drive many of the standard switching topologies. The single-ended configurations include buck, boost, flyback and forward converters. The double-ended devices control push-pull, half bridge and full bridge configurations.

Table 1. Single-Ended Controllers

These single-ended voltage and current mode controllers are designed for use in buck, boost, flyback, and forward converters. They are cost effective in applications that range from 0.1 to 200 W power output.

I _O (mA) Max	Minimum Operating Voltage Range (V)	Operating Mode	Reference (V)	Maximum Useful Oscillator Frequency (kHz)	Device	T _A (°C)	Package
500 (Uncommitted Drive Output)	7.0 to 40	Voltage	5.0 ± 1.5%	200	MC34060A	0 to +70	SO-14 DIP-14
					MC33060A	-40 to +85	SO-14 DIP-14
1000 (Totem Pole MOSFET Drive Output)	11.5 to 30	Current	5.0 ± 2.0%	500	UC3842A	0 to +70	SO-14 DIP-8
					UC2842A	-25 to +85	SO-14 DIP-8
					UC3843A	0 to +70	SO-14 DIP-8
					UC2843A	-25 to +85	SO-14 DIP-8
					UC3844	0 to +70	SO-14 DIP-8
					UC2844	-25 to +85	SO-14 DIP-8
					UC3845	0 to +70	SO-14 DIP-8
					UC2845	-25 to +85	SO-14 DIP-8
					UC3842B	0 to +70	SO-14 SO-8 DIP-8
					UC3842BV	-40 to +105	SO-14 SO-8 DIP-8
					UC3842A	0 to +70	SO-14 DIP-8
					UC2842A	-25 to +85	SO-14 DIP-8
					UC3843A	0 to +70	SO-14 DIP-8
					UC2843A	-25 to +85	SO-14 DIP-8
					UC3844	0 to +70	SO-14 DIP-8
					UC2844	-25 to +85	SO-14 DIP-8
UC3845	0 to +70	SO-14 DIP-8					
UC2845	-25 to +85	SO-14 DIP-8					

SMPSRM

Table 1. Single-Ended Controllers (continued)

These single-ended voltage and current mode controllers are designed for use in buck, boost, flyback, and forward converters. They are cost effective in applications that range from 0.1 to 200 W power output.

I_O (mA) Max	Minimum Operating Voltage Range (V)	Operating Mode	Reference (V)	Maximum Useful Oscillator Frequency (kHz)	Device	T_A (°C)	Package	
1000 (Totem Pole MOSFET Drive Output)	11 to 30	Current	5.0 ± 1.0%	500 (Improved Oscillator Specifications with Frequency Guaranteed at 250 kHz)	UC2842B	-25 to +85	SO-14	
							SO-8	
					DIP-8			
	8.2 to 30		5.0 ± 2.0%		UC3843B	0 to +70	SO-14	
							SO-8	
							DIP-8	
					UC3843BV	-40 to +105	SO-14	
							SO-8	
							DIP-8	
					5.0 ± 1.0%		UC2843B	-25 to +85
						SO-8		
						DIP-8		
	11.5 to 30		5.0 ± 2.0%	500 (50% Duty Cycle Limit)		UC3844B	0 to +70	SO-14
								SO-8
								DIP-8
						UC3844BV	-40 to +105	SO-14
								SO-8
								DIP-8
	11 to 30		5.0 ± 1.0%		UC2844B	-25 to +85	SO-14	
							SO-8	
				DIP-8				
8.2 to 30	5.0 ± 2.0%		UC3845B	0 to +70	SO-14			
					SO-8			
					DIP-8			
				UC3845BV	-40 to +105	SO-14		
						SO-8		
						DIP-8		
	5.0 ± 1.0%		UC2845B	-25 to +85	SO-14			
			SO-8					
			DIP-8					
2000 (Totem Pole MOSFET Drive Output)	9.2 to 30	Current or Voltage	5.1 ± 1.0%	1000	MC34023P	0 to +70	DIP-16	
					MC33023DW		-40 to +105	SO-16L

Table 2. Double-Ended Controllers

These double-ended voltage, current and resonant mode controllers are designed for use in push-pull, half-bridge, and full-bridge converters. They are cost effective in applications that range from 100 to 2000 watts power output.

I_O (mA) Max	Minimum Operating Voltage Range (V)	Operating Mode	Reference (V)	Maximum Useful Oscillator Frequency (kHz)	Device	T_A (°C)	Package
500 (Uncommitted Drive Outputs)	7.0 to 40	Voltage	$5.0 \pm 5.0\%$ ⁽¹⁾	200	TL494	0 to +70	DIP-16
						-25 to +85	DIP-16
			$5.0 \pm 1.5\%$	300	TL594	0 to +70	DIP-16
						-25 to +85	DIP-16
± 500 (Totem Pole MOSFET Drive Outputs)	8.0 to 40	Voltage	$5.1 \pm 2.0\%$	400	SG3525A	0 to +70	DIP-16
						± 200 (Totem Pole MOSFET Drive Outputs)	$5.0 \pm 2.0\%$
± 1500 (Totem Pole MOSFET Drive Outputs)	9.6 to 20	Resonant (Zero Current)	$5.1 \pm 2.0\%$	1000	MC34066	0 to +70	
					MC33066	-40 to +85	SO-16L
						DIP-16	
		Resonant (Zero Voltage)		2000	MC34067	0 to +70	SO-16L
					MC33067	-40 to +85	DIP-16
						SO-16L	
2000 (Totem Pole MOSFET Drive Outputs)	9.2 to 30	Current or Voltage	$5.1 \pm 1.0\%$	1000	MC34025	0 to +70	SO-16L
					MC33025	-40 to +105	DIP-16
						SO-16L	

(1) Tolerance applies over the specified operating temperature range.

(2) Junction Temperature Range.

Special Switching Regulator Controllers

These high performance dual channel controllers are optimized for off-line, ac-to-dc power supplies and dc-to-dc converters in the flyback topology. They also have undervoltage lockout voltages which are optimized

for off-line and lower voltage dc-to-dc converters, respectively. Applications include desktop computers, peripherals, televisions, games, and various consumer appliances.

Table 3. Dual Channel Controllers

I_O (mA) Max	Minimum Operating Voltage Range (V)	Operating Mode	Reference (V)	Maximum Useful Oscillator Frequency (kHz)	Device	T_A (°C)	Package
±1000 (Totem Pole MOSFET Drive Outputs)	11 to 20	Current	5.0 ± 2.6%	500	MC33065	-40 to +85	SO-16L
							DIP-16
	8.4 to 20				MC33065	-40 to +85	SO-16L
							DIP-16

Switching Regulator Control Circuits (continued)

Single-Ended GreenLine™ Controllers

Enhanced Mixed Frequency Mode GreenLine™ PWM Controller: Fixed Frequency, Variable Frequency, Standby Mode

MC44603AP, DW

$T_A = -25^\circ$ to $+85^\circ\text{C}$, DIP-16, SO-16L

The MC44603A is an enhanced high performance controller that is specifically designed for off-line and dc-to-dc converter applications. This device has the unique ability of automatically changing operating modes if the converter output is overloaded, unloaded, or shorted, offering the designer additional protection for increased system reliability. The MC44603A has several distinguishing features when compared to conventional SMPS controllers. These features consist of a foldback facility for overload protection, a standby mode when the converter output is slightly loaded, a demagnetization detection for reduced switching stresses on transistor and diodes, and a high current totem pole output ideally suited for driving a power MOSFET. It can also be used for driving a bipolar transistor in low power converters ($< 150\text{ W}$). It is optimized to operate in discontinuous mode but can also operate in continuous mode. Its advanced design allows use in current mode or voltage mode control applications.

Current or Voltage Mode Controller

- Operation up to 250 kHz Output Switching Frequency
- Inherent Feed Forward Compensation
- Latching PWM for Cycle-by-Cycle Current Limiting
- Oscillator with Precise Frequency Control

High Safety Standby Ladder Mode GreenLine™ PWM Controller

MC44604P

$T_A = -25^\circ$ to $+85^\circ\text{C}$, DIP-16

The MC44604 is an enhanced high performance controller that is specifically designed for off-line and dc-to-dc converter applications.

The MC44604 is a modification of the MC44603. The MC44604 offers enhanced safety and reliable power management in its protection features (foldback, overvoltage detection, soft-start, accurate demagnetization detection). Its high current totem pole output is also ideally suited for driving a power MOSFET but can also be used for driving a bipolar transistor in low power converters ($< 150\text{ W}$).

In addition, the MC44604 offers a new efficient way to reduce the standby operating power by means of a

High Flexibility

- Externally Programmable Reference Current
- Secondary or Primary Sensing
- Synchronization Facility
- High Current Totem Pole Output
- Undervoltage Lockout with Hysteresis

Safety/Protection Features

- Overvoltage Protection Against Open Current and Open Voltage Loop
- Protection Against Short Circuit on Oscillator Pin
- Fully Programmable Foldback
- Soft-Start Feature
- Accurate Maximum Duty Cycle Setting
- Demagnetization (Zero Current Detection) Protection
- Internally Trimmed Reference
- Enhanced Output Drive

GreenLine Controller: Low Power Consumption in Standby Mode

- Low Startup and Operating Current
- Fully Programmable Standby Mode
- Controlled Frequency Reduction in Standby Mode
- Low dV/dT for Low EMI Radiations

patented standby ladder mode operation of the converter significantly reducing the converter consumption in standby mode.

Current or Voltage Mode Controller

- Operation Up to 250 kHz Output Switching Frequency
- Inherent Feed Forward Compensation
- Latching PWM for Cycle-by-Cycle Current Limiting
- Oscillator with Precise Frequency Control

High Flexibility

- Externally Programmable Reference Current
- Secondary or Primary Sensing
- High Current Totem Pole Output
- Undervoltage Lockout with Hysteresis

SMPSRM

Single-Ended GreenLine™ Controllers (continued)

High Safety Standby Ladder Mode GreenLine™ PWM Controller (continued)

Safety/Protection Features

- Overvoltage Protection Facility Against Open Loop
- Protection Against Short Circuit on Oscillator Pin
- Fully Programmable Foldback
- Soft-Start Feature
- Accurate Maximum Duty Cycle Setting
- Demagnetization (Zero Current Detection) Protection

- Internally Trimmed Reference

GreenLine™ Controller:

- Low Startup and Operating Current
- Patented Standby Ladder Mode for Low Standby Losses
- Low dV/dT for Low EMI

High Safety Latched Mode GreenLine™ PWM Controller for (Multi)Synchronized Applications

MC44605P

$T_A = -25^\circ$ to $+85^\circ\text{C}$, DIP-16

The MC44605 is a high performance current mode controller that is specifically designed for off-line converters. The MC44605 has several distinguishing features that make it particularly suitable for multisynchronized monitor applications.

The MC44605 synchronization arrangement enables operation from 16 kHz up to 130 kHz. This product was optimized to operate with universal ac mains voltage from 80 V to 280 V, and its high current totem pole output makes it ideally suited for driving a power MOSFET.

The MC44605 protections provide well controlled, safe power management. Safety enhancements detect four different fault conditions and provide protection through a disabling latch.

Current or Voltage Mode Controller

- Current Mode Operation Up to 250 kHz Output Switching Frequency
- Inherent Feed Forward Compensation
- Latching PWM for Cycle-by-Cycle Current Limiting
- Oscillator with Precise Frequency Control
- Externally Programmable Reference Current
- Secondary or Primary Sensing (Availability of Error Amplifier Output)
- Synchronization Facility

- High Current Totem Pole Output
- Undervoltage Lockout with Hysteresis
- Low Output dV/dT for Low EMI
- Low Startup and Operating Current

Safety/Protection Features

- Soft-Start Feature
- Demagnetization (Zero Current Detection) Protection
- Overvoltage Protection Facility Against Open Loop
- EHT Overvoltage Protection (E.H.T.OVP): Protection Against Excessive Amplitude Synchronization Pulses
- Winding Short Circuit Detection (W.S.C.D.)
- Limitation of the Maximum Input Power (M.P.L.): Calculation of Input Power for Overload Protection
- Over Heating Detection (O.H.D.): to Prevent the Power Switch from Excessive Heating

Latched Disabling Mode

- When one of the following faults is detected: EHT overvoltage, Winding Short Circuit (WSCD), excessive input power (M.P.L.), power switch over heating (O.H.D.), a counter is activated
- If the counter is activated for a time that is long enough, the circuit gets definitively disabled. The latch can only be reset by removing and then re-applying power

Few External Components Reliable and Flexible GreenLine™ Very High Voltage PWM Controller

MC44608

$T_A = -25^\circ$ to $+85^\circ\text{C}$, DIP-8

The MC44608 is a high performance voltage mode controller designed for off-line converters. This high voltage circuit that integrates the start-up current source and the oscillator capacitor, requires few external components while offering a high flexibility and reliability.

The device also features a very high efficiency stand-by management consisting of an effective Pulsed Mode operation. This technique enables the reduction of the stand-by power consumption to approximately 1W while delivering 300mW in a 150W SMPS.

- Integrated Start-Up Current Source
- Lossless Off-Line Start-Up
- Direct Off-Line Operation
- Fast Start-Up

General Features

- Flexibility
- Duty Cycle Control

- Undervoltage Lockout with Hysteresis
- On Chip Oscillator Switching Frequency 40, 75, or 100kHz
- Secondary control with Few External Components

Protections

- Maximum Duty Cycle Limitation
- Cycle by Cycle Current Limitation
- Demagnetization (Zero Current Detection) Protection
- “Over V_{CC} Protection” Against Open Loop
- Programmable Low Inertia Over Voltage Protection against open loop
- Internal Thermal Protection

GreenLine™ Controller

- Pulsed Mode Techniques for a Very High Efficiency Low Power Mode
- Lossless Startup
- Low dV/dT for Low EMI Radiations

ORDERING INFORMATION

Device	Operating Temperature Range	Package	Switching Frequency
MC44608P40	$T_J = -25^\circ$ to $+85^\circ\text{C}$	Plastic DIP-8	40 kHz
MC44608P75			75 kHz
MC44608P100			100 kHz

SMPSRM

Representative Block Diagram

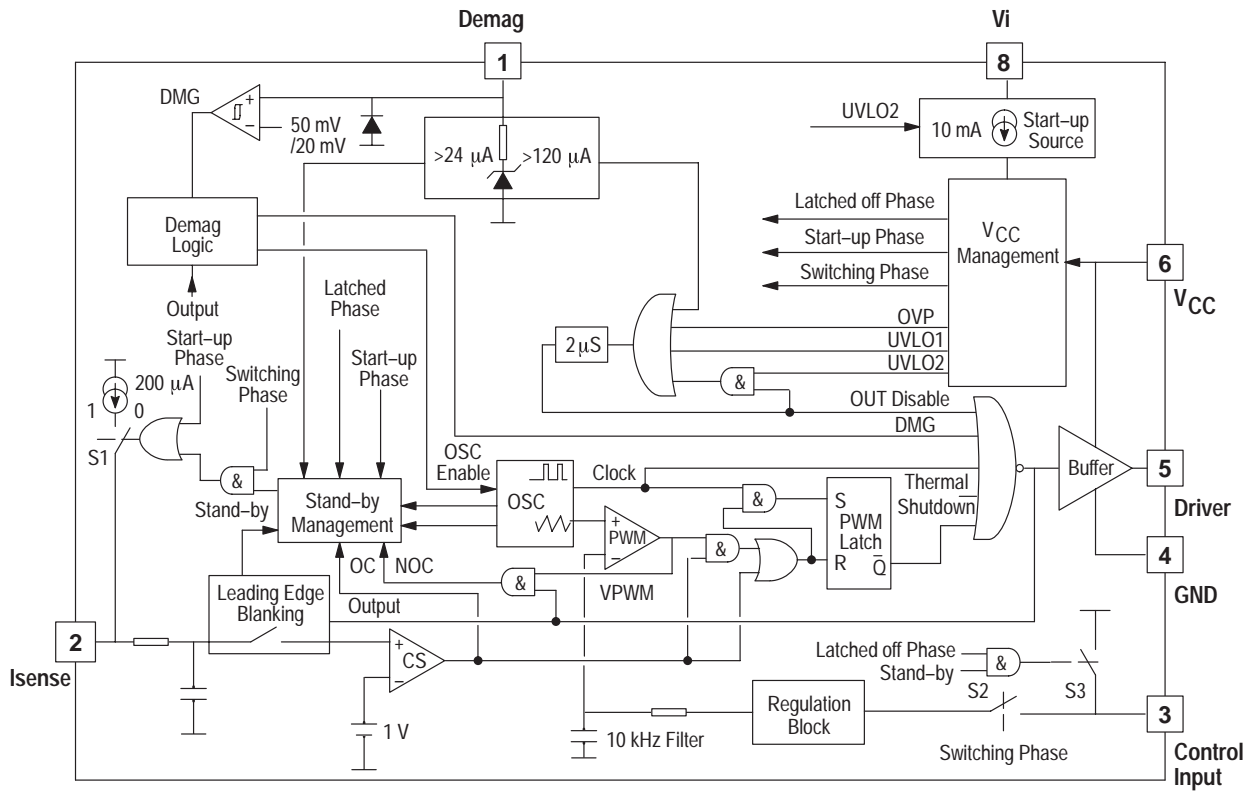

Critical Conduction SMPS Controller

MC33364D, D1, D2

T_J = -25° to +125°C, SO-8, SO-16

The MC33364 series are variable frequency SMPS controllers that operate in the critical conduction mode. They are optimized for low power, high density power supplies requiring minimum board area, reduced component count, and low power dissipation. Each narrow body SOIC package provides a small footprint. Integration of the high voltage startup saves approximately 0.7 W of power compared to resistor bootstrapped circuits.

Each MC33364 features an on-board reference, UVLO function, a watchdog timer to initiate output switching, a zero current detector to ensure critical conduction operation, a current sensing comparator, leading edge blanking, and a CMOS driver. Protection features include the ability to shut down switching, and cycle-by-cycle current limiting.

The MC33364D1 is available in a surface mount SO-8 package. It has an internal 126 kHz frequency

clamp. For loads which have a low power operating condition, the frequency clamp limits the maximum operating frequency, preventing excessive switching losses and EMI radiation.

The MC33364D2 is available in the SO-8 package without an internal frequency clamp.

The MC33364D is available in the SO-16 package. It has an internal 126 kHz frequency clamp which is pinned out, so that the designer can adjust the clamp frequency by connecting appropriate values of resistance and capacitance.

- Lossless Off-Line Startup
- Leading Edge Blanking for Noise Immunity
- Watchdog Timer to Initiate Switching
- Minimum Number of Support Components
- Shutdown Capability
- Over Temperature Protection
- Optional Frequency Clamp

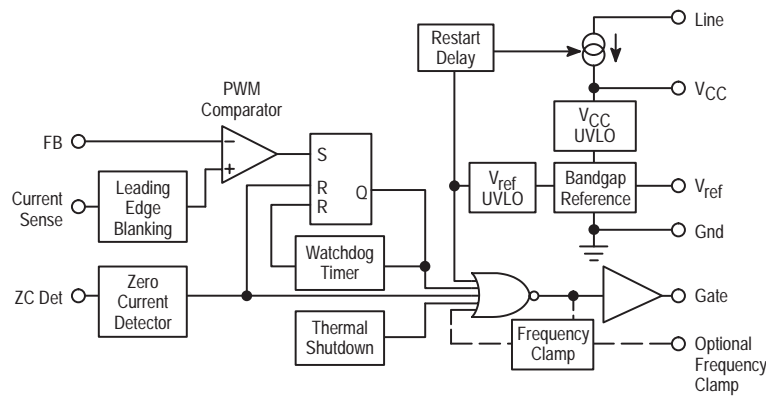

High Voltage Off-Line Switching Regulators

In Brief . . .

These high performance switching controllers are optimized for low power off-line converters using flyback topology. These switching regulators have on-board switch transistors. Applications include AC/DC adapters, battery chargers and various consumer appliances.

	Page
Very High Voltage Switching Regulator	84
Very High Voltage Switching Regulator	86

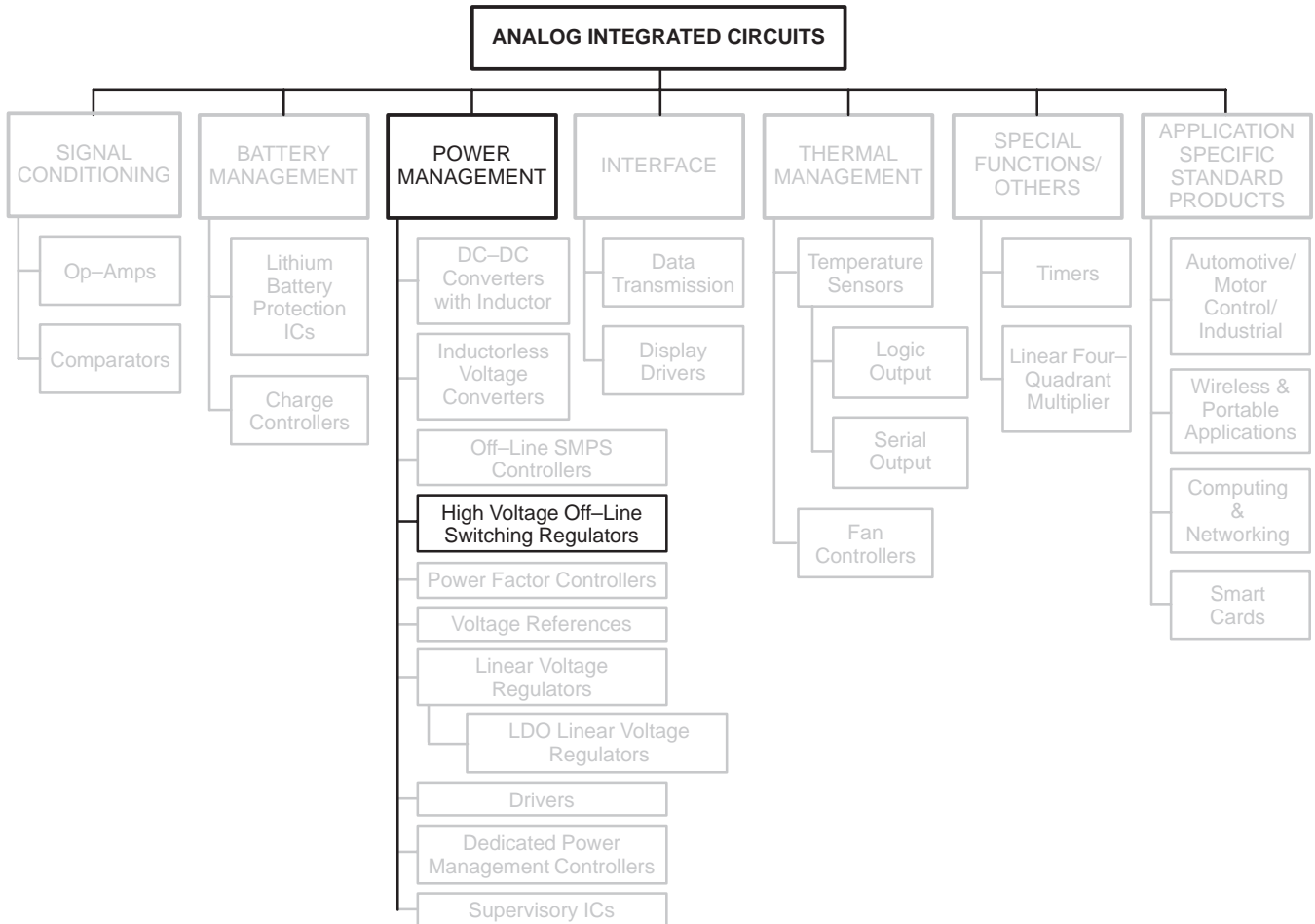

Table 1. Very High Voltage Single-Ended Controller with On-Chip Power Switch

This monolithic high voltage switching regulator is specifically designed to operate from a rectified ac line voltage source. Included are an on-chip high voltage power switch, active off-line startup circuitry and a full featured PWM controller with fault protection.

Device	Rectified 85 to 276 VAC Line	Power Switch MOSFET Integrated	Max Drain Voltage	Peak Current	$R_{DS(on)}$ (typ. @ $T_j = 25^\circ\text{C}$)	Max Output Power @ $V_{in} = 92\text{V}$ to 265 VAC	Start-Up	Control Scheme	Oscillator Frequency	Package	Temperature Range	Additional Features
MC33362	ONLY 110 V Operation	Yes	500 V	2A	4.4 Ω	20W	Active On-Chip 250 V FET	<ul style="list-style-type: none"> • PWM, Fixed Frequency • Voltage Mode 	Adjustable up to 300 kHz	DIP-16 SO-16WB	-25 to +125°C	
MC33363A	Yes	Yes	700 V	1A	7.5 Ω	14W	Active On-Chip 500 V FET	<ul style="list-style-type: none"> • PWM, Fixed Frequency • Voltage Mode 	Adjustable up to 300 kHz	DIP-16 SO-16WB	-25 to +125°C	
MC33363B	Yes	Yes	700 V	1A	15 Ω	8W	Active On-Chip 450 V FET	<ul style="list-style-type: none"> • PWM, Fixed Frequency • Voltage Mode 	Adjustable up to 300 kHz	DIP-16 SO-16WB	-25 to +125°C	
MC33365	Yes	Yes	700 V	1A	15 Ω	8W	Active On-Chip 450 V FET	<ul style="list-style-type: none"> • PWM, Fixed Frequency • Voltage Mode 	Adjustable up to 300 kHz	DIP-16	-25 to +125°C	Bulk Capacitor Voltage Sensing Capability to Sense an AC Line Brown-Out

Very High Voltage Switching Regulator

MC33362DW, P

T_J = -25° to +125°C, DIP-16, SOP-16L

The MC33362 is a monolithic high voltage switching regulator that is specifically designed to operate from a rectified 120 VAC line source. This integrated circuit features an on-chip 500 V/2.0 A SENSEFET power switch, 250 V active off-line startup FET, duty cycle controlled oscillator, current limiting comparator with a programmable threshold and leading edge blanking, latching pulse width modulator for double pulse suppression, high gain error amplifier, and a trimmed internal bandgap reference. Protective features include cycle-by-cycle current limiting, input undervoltage lockout with hysteresis, output overvoltage protection, and thermal shutdown. This device is available in a 16-lead dual-in-line and wide body surface mount packages.

and thermal shutdown. This device is available in a 16-lead dual-in-line and wide body surface mount packages.

- On-Chip 500 V, 2.0 A SENSEFET Power Switch
- Rectified 120 VAC Line Source Operation
- On-Chip 250 V Active Off-Line Startup FET
- Latching PWM for Double Pulse Suppression
- Cycle-By-Cycle Current Limiting
- Input Undervoltage Lockout with Hysteresis
- Output Overvoltage Protection Comparator
- Trimmed Internal Bandgap Reference
- Internal Thermal Shutdown

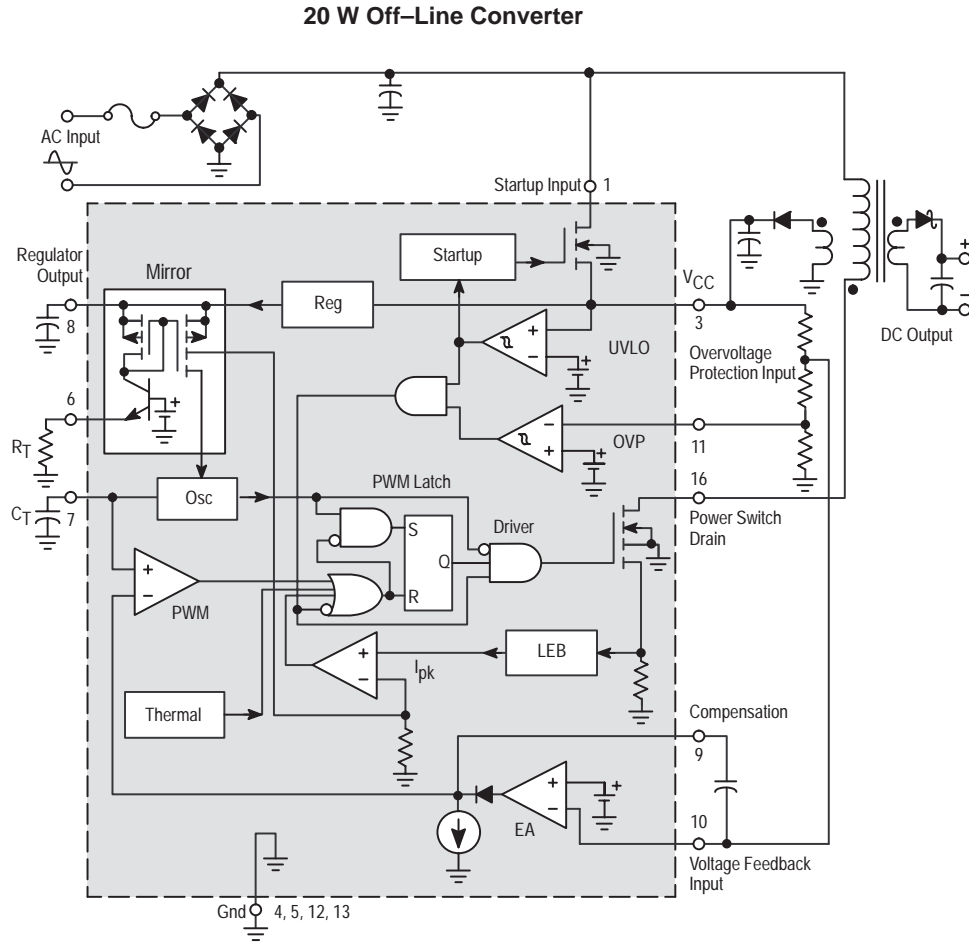

Switching Regulator Control Circuits (continued)

Very High Voltage Switching Regulator

MC33363ADW, AP

T_J = -25° to +125°C, DIP-16, SOP-16L

The MC33363A is a monolithic high voltage switching regulator that is specifically designed to operate from a rectified 240 Vac line source. This integrated circuit features an on-chip 700 V/1.5 A SENSEFET power switch, 550 V active off-line startup FET, duty cycle controlled oscillator, current limiting comparator with a programmable threshold and leading edge blanking, latching pulse width modulator for double pulse suppression, high gain error amplifier, and a trimmed internal bandgap reference. Protective features include cycle-by-cycle current limiting, input undervoltage lockout with hysteresis, output overvoltage protection, and

and thermal shutdown. This device is available in a 16-lead dual-in-line and wide body surface mount packages.

- On-Chip 700 V, 1.5 A SENSEFET Power Switch
- Rectified 240 Vac Line Source Operation
- On-Chip 500 V Active Off-Line Startup FET
- Latching PWM for Double Pulse Suppression
- Cycle-By-Cycle Current Limiting
- Input Undervoltage Lockout with Hysteresis
- Output Overvoltage Protection Comparator
- Trimmed Internal Bandgap Reference
- Internal Thermal Shutdown

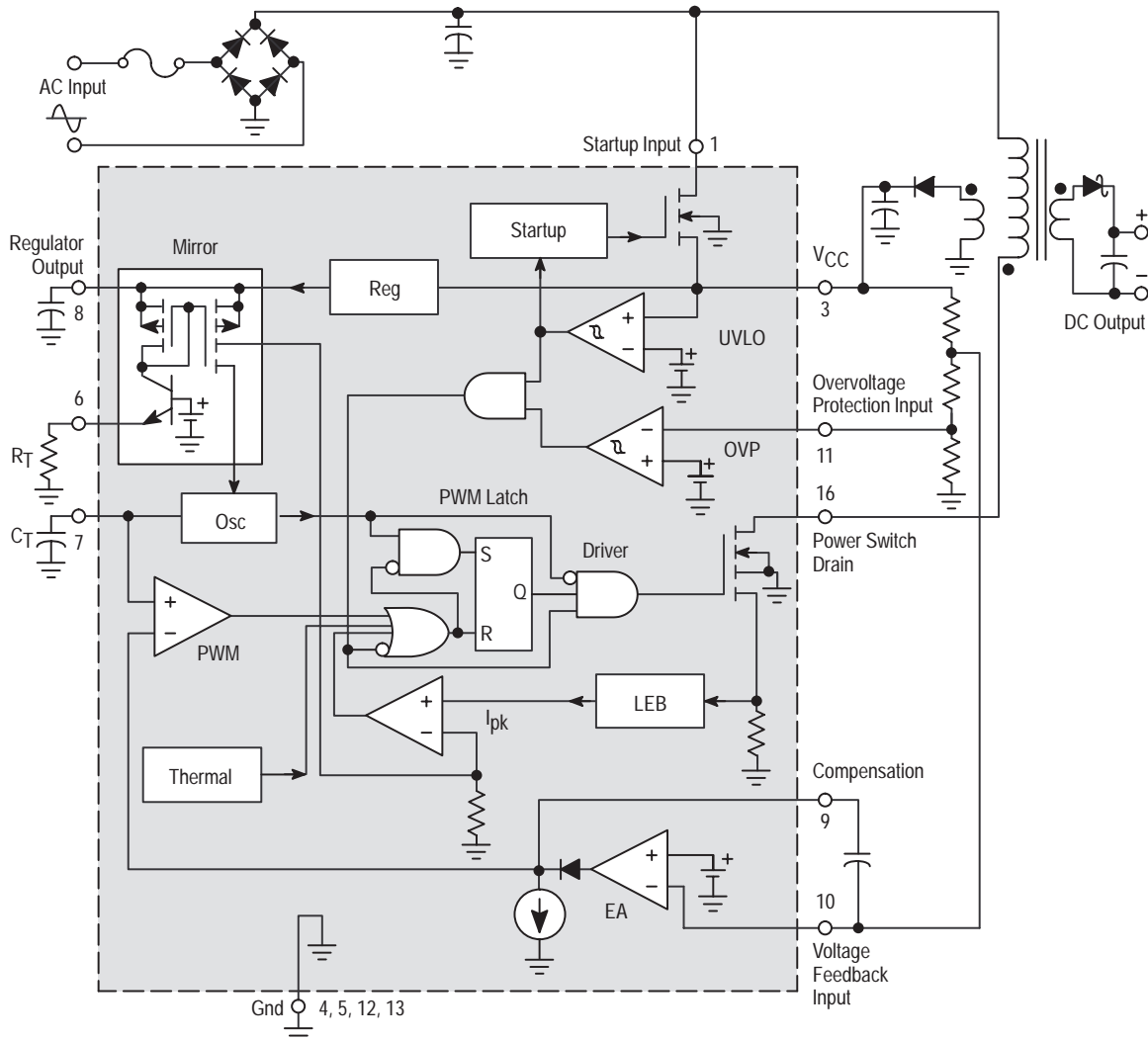

SMPSRM

Switching Regulator Control Circuits (continued)

High Voltage Switching Regulator

MC33363B

T_J = -25° to +125°C

The MC33363B is a monolithic high voltage switching regulator that is specifically designed to operate from a rectified 240 Vac line source. This integrated circuit features an on-chip 700 V/1.0 A SENSEFET power switch, 450 V active off-line startup FET, duty cycle controlled oscillator, current limiting comparator with a programmable threshold and leading edge blanking, latching pulse width modulator for double pulse suppression, high gain error amplifier, and a trimmed internal bandgap reference. Protective features include cycle-by-cycle current limiting, input undervoltage lockout with hysteresis, overvoltage protection, and thermal shutdown. This

device is available in a 16-lead dual-in-line and wide body surface mount packages.

- On-Chip 700 V, 1.0 A SENSEFET Power Switch
- Rectified 240 Vac Line Source Operation
- On-Chip 450 V Active Off-Line Startup FET
- Latching PWM for Double Pulse Suppression
- Cycle-By-Cycle Current Limiting
- Input Undervoltage Lockout with Hysteresis
- Output Overvoltage Protection
- Trimmed Internal Bandgap Reference
- Internal Thermal Shutdown

ORDERING INFORMATION

Device	Operating Temperature Range	Package
MC33363BDW	T _J = -25° to +125°C	SOP-16L
MC33363BP		DIP-16

Simplified Application

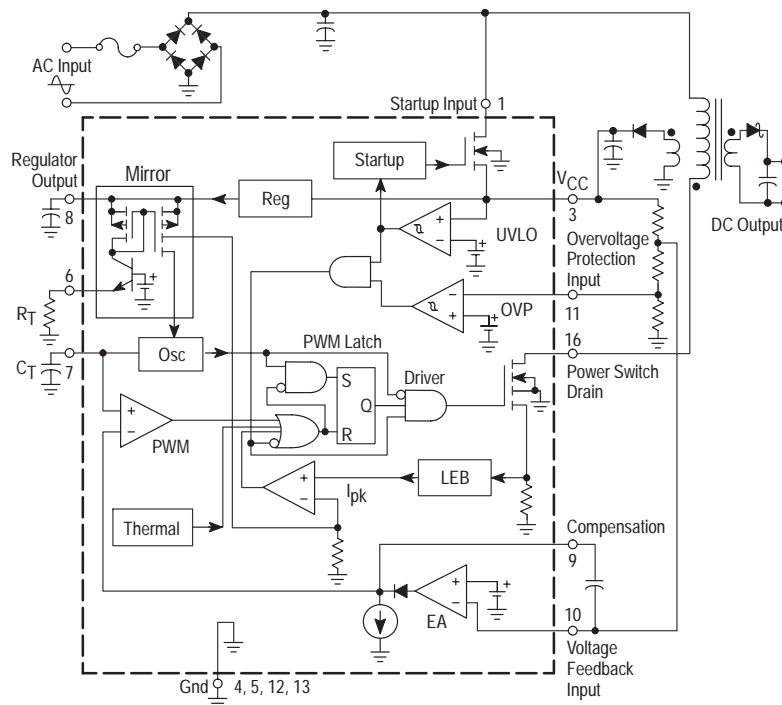

Switching Regulator Control Circuits (continued)

High Voltage Switching Regulator

MC33365

T_J = -25° to +125°C, DIP-16

The MC33365 is a monolithic high voltage switching regulator that is specifically designed to operate from a rectified 240 Vac line source. This integrated circuit features an on-chip 700 V/1.0 A SENSEFET power switch, 450 V active off-line startup FET, duty cycle controlled oscillator, current limiting comparator with a programmable threshold and leading edge blanking, latching pulse width modulator for double pulse suppression, high gain error amplifier, and a trimmed internal bandgap reference. Protective features include cycle-by-cycle current limiting, input undervoltage lockout with hysteresis,

bulk capacitor voltage sensing, and thermal shutdown. This device is available in a 16-lead dual-in-line package.

- On-Chip 700 V, 1.0 A SENSEFET Power Switch
- Rectified 240 Vac Line Source Operation
- On-Chip 450 V Active Off-Line Startup FET
- Latching PWM for Double Pulse Suppression
- Cycle-By-Cycle Current Limiting
- Input Undervoltage Lockout with Hysteresis
- Bulk Capacitor Voltage Comparator
- Trimmed Internal Bandgap Reference
- Internal Thermal Shutdown

ORDERING INFORMATION

Device	Operating Temperature Range	Package
MC33365P	T _J = -25° to +125°C	DIP-16

Simplified Application

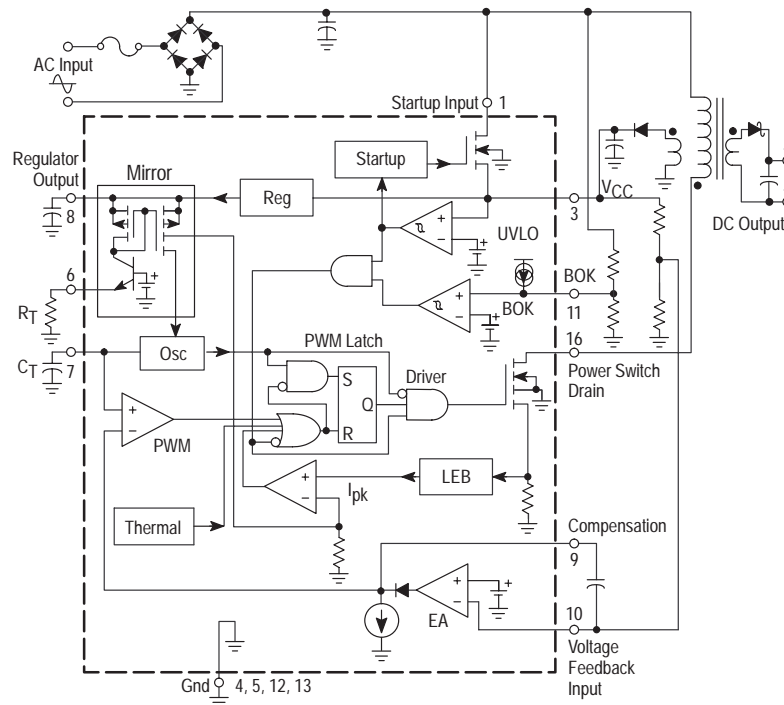

Power Factor Controllers

In Brief . . .

The new PFC's are developed to control Power Factor Correction pre-converters meeting IEC1000-3-2 standard requirements in electronic ballast and off-line power conversion applications. These devices are designed to work in free frequency critical conduction mode. They can be synchronized and feature very effective protection to ensure a safe and reliable operation. They also optimized to offer extremely compact and cost-effective PFC solutions. Ultimately, the solution system cost is significantly lowered. The portfolio offers products that can propose a free output voltage level mode (follower boost technique) that enables a drastic size reduction of both the inductor and the power MOSFET. Also, they are able to function in a traditional way (constant output voltage regulation level), and any intermediary solutions can be easily implemented. This flexibility makes them ideal to optimally cope with a wide range of applications.

	Page
Power Factor Controllers	89
GreenLine™ Power Factor Controller	92

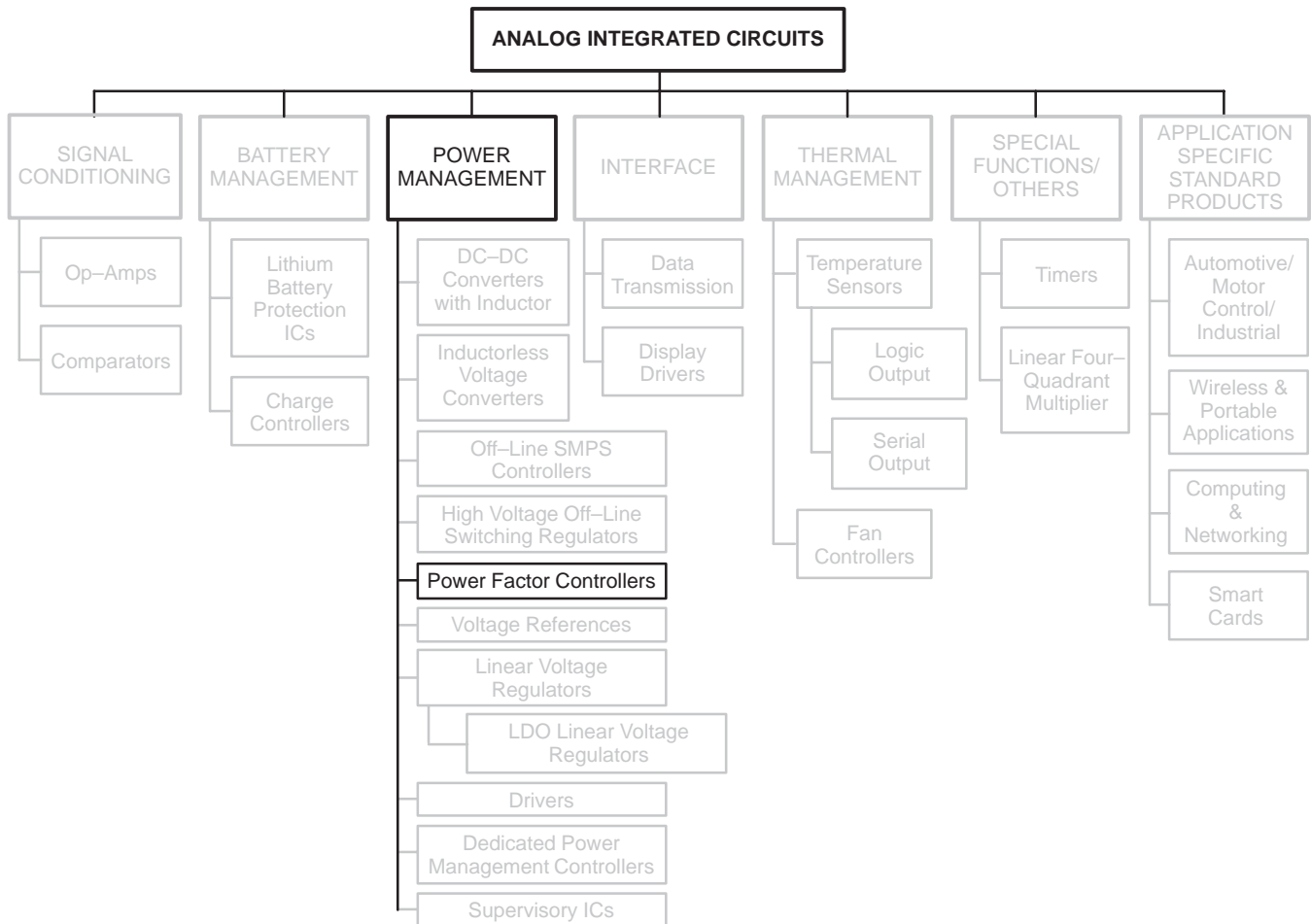

Table 1. Power Factor Controllers

I_O (mA) Max	Minimum Operating Voltage Range (V)	Maximum Startup Voltage (V)	Reference (V)	Features	Device	T_A (°C)	Package				
± 500 (Totem Pole MOSFET Drive Outputs)	9.0 to 30	30	$2.5 \pm 1.4\%$	Undervoltage Lockout, Internal Startup Timer	MC34261	0 to +70	DIP-8				
					MC33261	-40 to +85	SO-8 DIP-8				
				Overvoltage Comparator, Undervoltage Lockout, Internal Startup Timer	MC34262	0 to +85	SO-8 DIP-8				
					MC33262	-40 to +105	SO-8 DIP-8				
				1500 (CMOS Totem Pole MOSFET Drive Outputs)	9.0 to 16	500	$5.0 \pm 1.5\%$	Off-Line High Voltage Startup Overvoltage Comparator, Undervoltage Lockout, Timer, Low Load Detect	MC33368	-25 to +125	SO-16
											DIP-16

SMPSRM

Power Factor Controllers

MC34262D, P

$T_A = 0^\circ$ to $+85^\circ\text{C}$, DIP-8, SO-8

MC33262D, P

$T_A = -40^\circ$ to $+105^\circ\text{C}$, DIP-8, SO-8

The MC34262, MC33262 series are active power factor controllers specifically designed for use as a preconverter in electronic ballast and in off-line power converter applications. These integrated circuits feature an internal startup timer for stand alone applications, a one quadrant multiplier for near unity power factor, zero current detector to ensure critical conduction operation, transconductance error amplifier, quickstart circuit for enhanced startup, trimmed internal bandgap reference, current sensing comparator, and a totem pole output ideally suited for driving a power MOSFET.

Also included are protective features consisting of an overvoltage comparator to eliminate runaway output voltage due to load removal, input undervoltage lockout with hysteresis, cycle-by-cycle current limiting, multiplier output clamp that limits maximum peak switch current, an RS latch for single pulse metering, and a drive output high state clamp for MOSFET gate protection. These devices are available in dual-in-line and surface mount plastic packages.

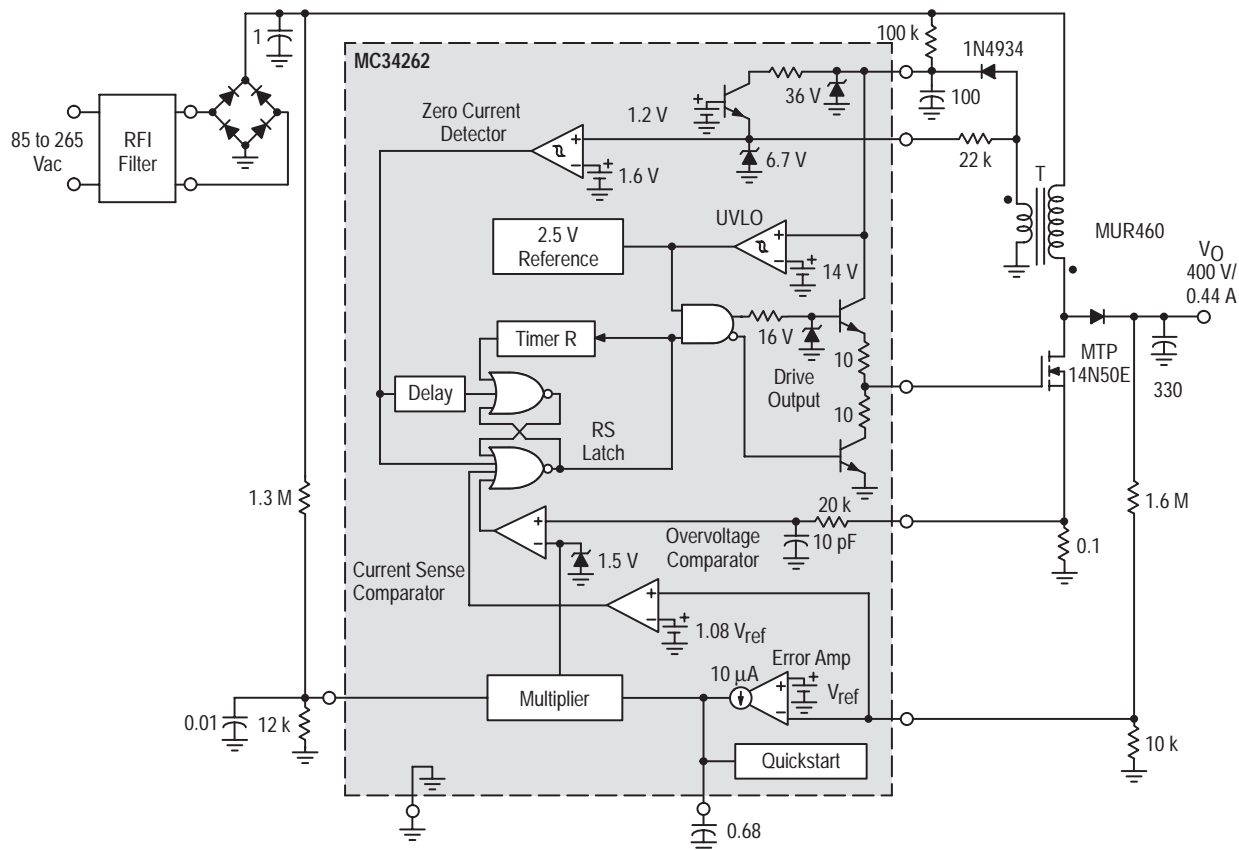

Power Factor Controllers (continued)

MC33368D, P

T_J = -25° to +125°C, DIP-16, SO-16

The MC33368 is an active power factor controller that functions as a boost preconverter in off-line power supply applications. MC33368 is optimized for low power, high density power supplies requiring minimum board area, reduced component count, and low power dissipation. The narrow body SOIC package provides a small footprint. Integration of the high voltage startup saves approximately 0.7 W of power compared to resistor bootstrapped circuits.

The MC33368 features a watchdog timer to initiate output switching, a one quadrant multiplier to force the line current to follow the instantaneous line voltage, a zero current detector to ensure critical conduction operation, a transconductance error amplifier, a current sens-

ing comparator, a 5.0 V reference, an undervoltage lock-out (UVLO) circuit which monitors the V_{CC} supply voltage, and a CMOS driver for driving MOSFETs. The MC33368 also includes a programmable output switching frequency clamp. Protection features include an output overvoltage comparator to minimize overshoot, a restart delay timer, and cycle-by-cycle current limiting.

- Lossless Off-Line Startup
- Output Overvoltage Comparator
- Leading Edge Blanking (LEB) for Noise Immunity
- Watchdog Timer to Initiate Switching
- Restart Delay Timer

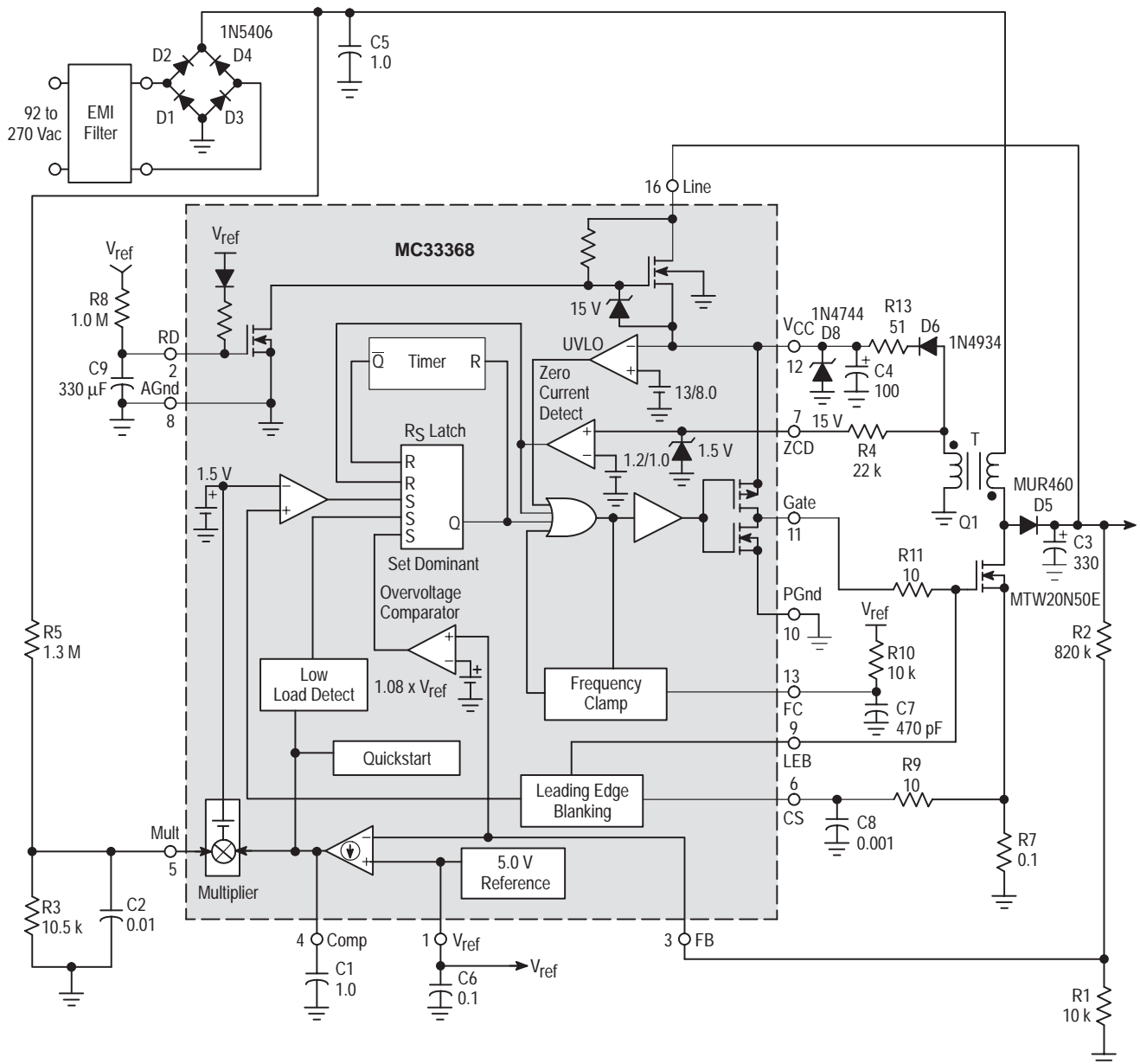

SMPSRM

GreenLine™ Power Factor Controller

MC33260P

The MC33260 is developed to control Power Factor Correction preconverters meeting IEC1000–3–2 standard requirements in electronic ballast and off–line power conversion applications. Designed to work in free frequency critical conduction mode, it can also be synchronized and in any case, it features very effective protections to ensure a safe and reliable operation.

This circuit is also optimized to offer extremely compact and cost–effective PFC solutions. In effect, while requiring a minimum number of external components, the MC33260 also proposes a free output voltage level mode (follower boost technique) that enables a drastic size reduction of both the inductor and the power mosfet. Ultimately, the solution system cost is significantly lowered.

Also able to function in traditional way (constant output voltage regulation level), any intermediary solutions can be easily implemented. This flexibility makes it ideal to optimally cope with a wide range of applications.

General Features

- “Free Level” or Traditional Constant Output Level Mode
- Switch Mode Operation: Voltage Mode
- Latching PWM for Cycle–by–Cycle On–Time Control
- Totem Pole Gate Drive
- Undervoltage Lockout with Hysteresis
- Low Start–up and Operating Current
- Improved Regulation Block Dynamic Behaviour
- Synchronization Facility
- Internally Trimmed Reference Current Source

Safety/Protection Features

- Overvoltage Protection: Output Overvoltage Detection
- Undervoltage Protection: Protection Against Open Loop
- Accurate Demagnetization (Zero Current Detection) Protection
- Precise and Adjustable Maximum On–Time Limitation
- Over Current Protection

ORDERING INFORMATION

Device	Temperature Range	Package
MC33260P	–40° to +105°C	Plastic DIP–8

Typical Application

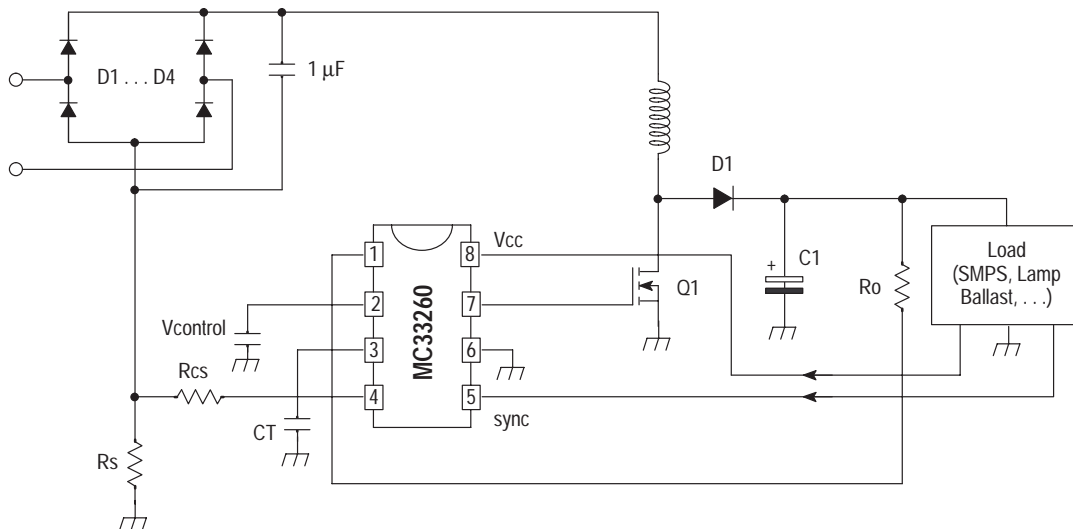

GreenLine is a trademark of Semiconductor Components Industries, LLC (SCILLC)

Voltage References

In Brief . . .

ON Semiconductor's line of precision voltage references is designed for applications requiring high initial accuracy, low temperature drift, and long term stability. Initial accuracies of $\pm 1.0\%$, and $\pm 2.0\%$ mean production line adjustments can be eliminated. Temperature coefficients of 25 ppm/ $^{\circ}\text{C}$ max (typically 10 ppm/ $^{\circ}\text{C}$) provide excellent stability. Uses for the references include D/A converters, A/D converters, precision power supplies, voltmeter systems, temperature monitors, and many others.

	Page
Precision Low Voltage References	94

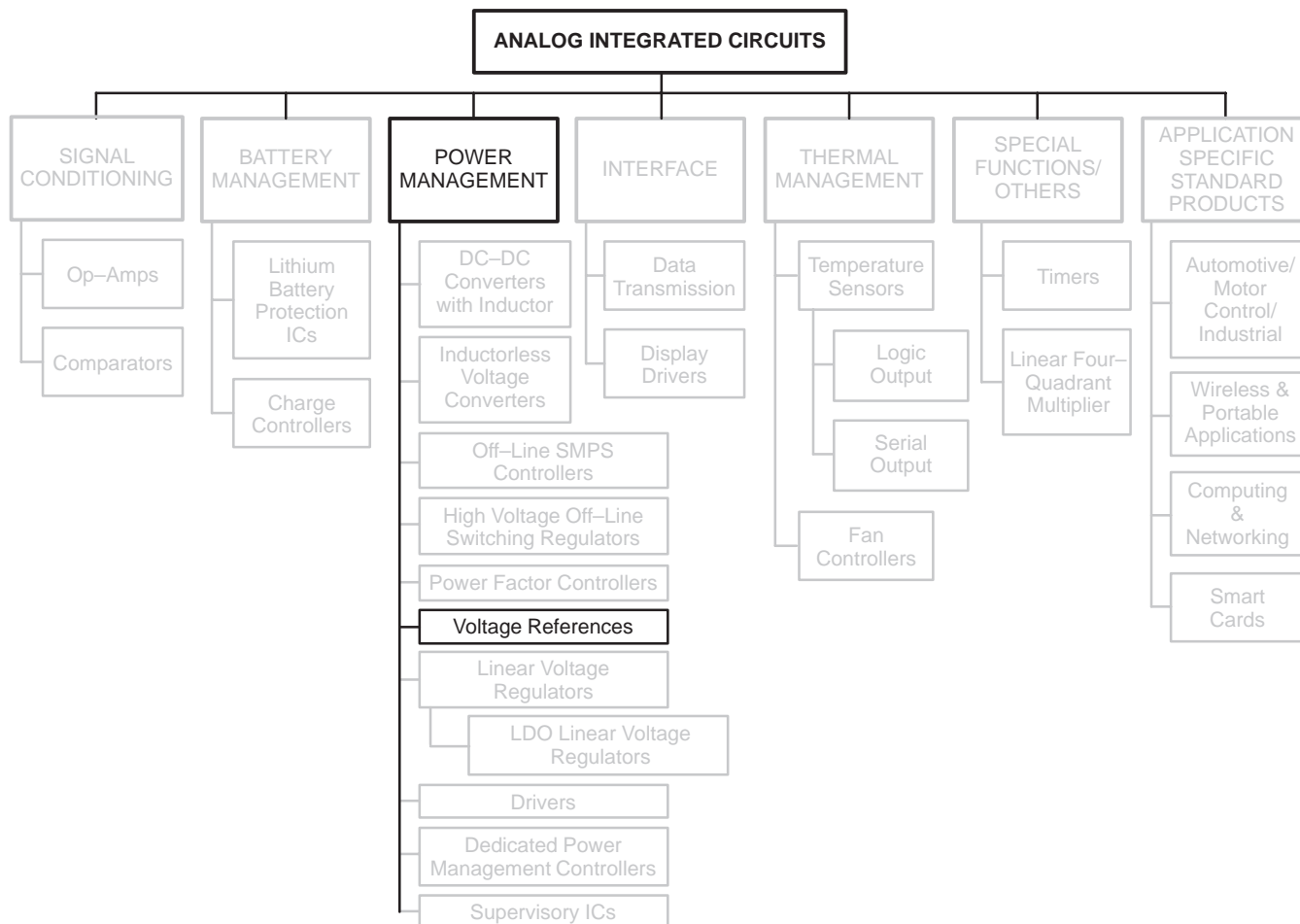

Precision Low Voltage References

A family of precision low voltage bandgap reference devices designed for applications requiring low temperature drift.

Table 1. Precision Low Voltage References

V _{out} (V) Typ	I _O (mA) Max	V _{out} /T (ppm/°C) Max	Device		Reg _{line} (mV) Max	Reg _{load} (mV) Max	Package
			0° to +70°C	-40° to +85°C			
1.235 ± 12 mV 1.235 ± 25 mV	20	80 Typ	LM385BZ-1.2 LM385Z-1.2	LM285Z-1.2	(Note 1)	1.0 (Note 2)	TO-92, SO-8
2.5 ± 38 mV 2.5 ± 75 mV			LM385BZ-2.5 LM385Z-2.5	LM285Z-2.5		2.0 (Note 3)	
2.5 ± 25 mV	10	25	MC1403B	-	3.0/4.5 (Note 4)	10 (Note 5)	SO-8, DIP-8
		40	MC1403				
2.5 to 37	100	50 Typ	TL431C, AC, BC	TL431I, AI, BI	Shunt Reference Dynamic Impedance (z) ≤ 0.5 Ω		TO-92, DIP-8, SO-8, Micro-8

- Notes: 1. Micropower Reference Diode Dynamic Impedance (z) ≤ 1.0 Ω at I_R = 100 μA.
 2. 10 μA ≤ I_R ≤ 1.0 mA.
 3. 20 μA ≤ I_R ≤ 1.0 mA.
 4. 4.5 V ≤ V_{in} ≤ 15 V/15 V ≤ V_{in} ≤ 40 V.
 5. 0 mA ≤ I_L ≤ 10 mA.

Linear Voltage Regulators

In Brief . . .

ON Semiconductor’s broad portfolio of voltage regulators covers the whole spectrum of current levels, from low current levels of 80 mA to very high current levels of up to 5 A, and in a very wide selection of voltages. All these products are available in multiple package versions with a strong emphasis on surface mount packages, from TSOP–5 or SOT23–5 leads up to D²PAK 5 leads.

New developments have included low dropout, more accuracy, and less noise using bipolar technology or CMOS technology for a reduction of current consumption.

	Page
Linear Voltage Regulators	96
Micropower Voltage Regulators for Portable Applications	100
Special Voltage Regulators	109
Special Regulators	109

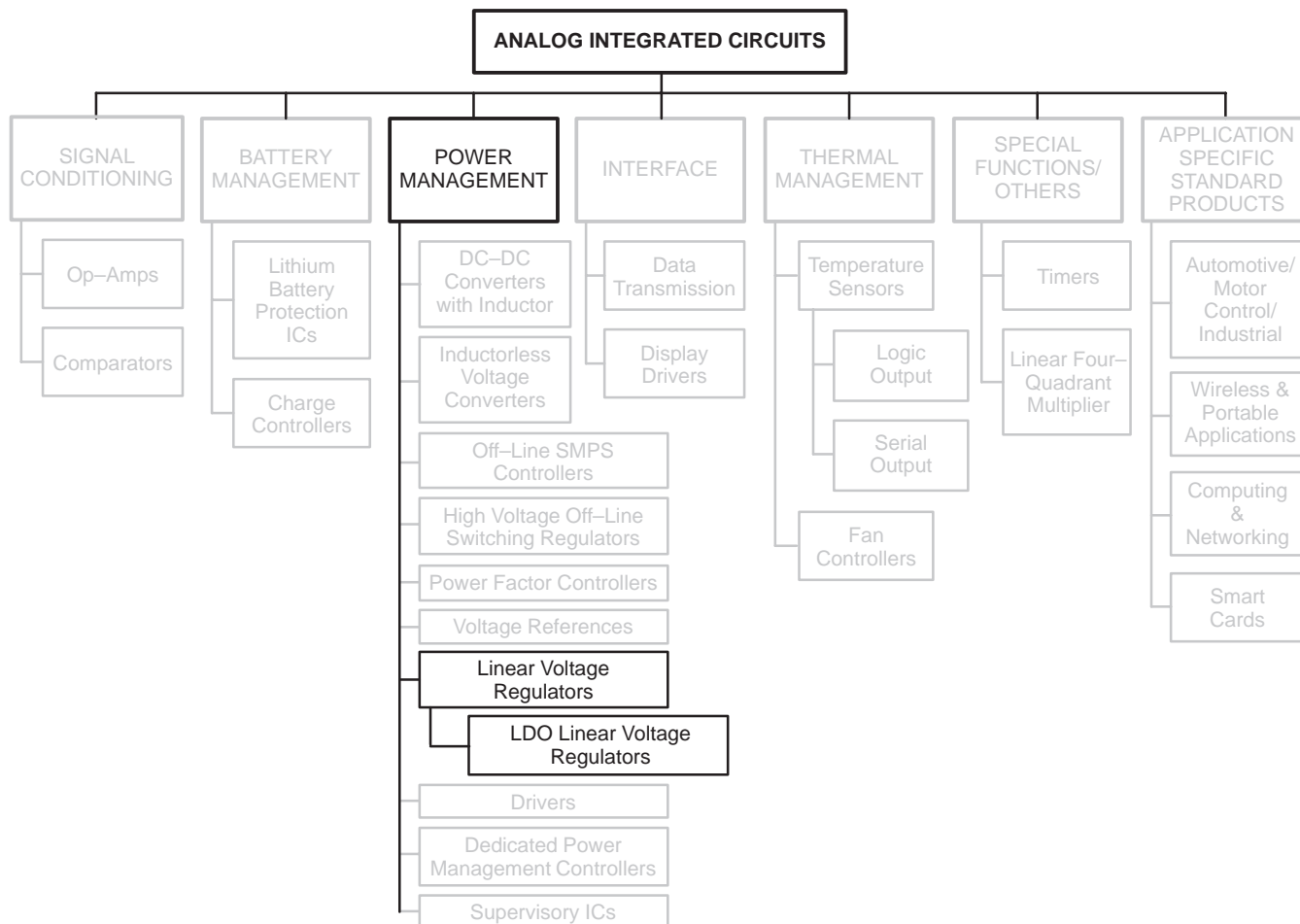

Linear Voltage Regulators

Fixed Output

These low cost monolithic circuits provide positive and/or negative regulation at currents from 100 mA to 3.0 A. They are ideal for on-card regulation employing current limiting and thermal shutdown. Low V_{Diff}

devices are offered for battery powered systems.

Although designed primarily as fixed voltage regulators, these devices can be used with external components to obtain adjustable voltages and currents.

Table 1. Linear Voltage Regulators

Device	V_{out}	25°C Tol. ±%	V_{in} Max	$V_{in}-V_{out}$ Diff. Typ.	Regline Max (% V_{out})	Regload Max (% V_{out})	Typ. Temp. Coefficient mV (V_{out}) °C	Package
--------	-----------	--------------	--------------	-----------------------------	----------------------------	----------------------------	--	---------

Fixed Voltage, 3-Terminal Regulators, 0.1 Amperes

LM2931*/A-5.0*	5.0	5.0/3.8	40	0.16	0.6	1.0	0.2	SO-8, TO-92, D ² PAK, DPAK, TO-220
LP2950C*/AC*	3.0	0.5	30	0.38	0.2/0.1	0.2/0.1	0.04	DPAK, TO-92
	3.3							DPAK, TO-92
	5.0							DPAK, TO-92
MC78LXXC/AC/AB*	5.0, 8.0, 9.0	8.0/4.0	30	1.7	4.0/3.0	1.2	0.2	DIP-8, SOP-8
MC78LXXC/AC/AB*	12, 15, 18	8.0/4.0	35	1.7	2.0	1.0	0.2	DIP-8, SOP-8
MC78L24C/AC/AB*	24	8.0/4.0	40	1.7	2.0	1.0	0.2	DIP-8, SOP-8
MC79L05C/AC/AB*	-5.0	8.0/4.0	30	1.7	4.0/3.0	1.2	0.2	DIP-8, SOP-8
MC79LXXC/AC/AB*	-(12, 15, 18)	8.0/4.0	35	1.7	2.0	1.0	0.2	DIP-8, SOP-8
MC79L24C/AC/AB*	-24	8.0/4.0	40	1.7	2.0	1.0	0.2	DIP-8, SOP-8
MC33160**	5.0	5.0	40	2.0	0.8	1.0	-	DIP-16, SO-16L

Fixed Voltage, 3-Terminal Regulators, 0.5 Amperes

MC78MXXB*/C	5.0, 6.0, 8.0, 12	4.0	35	2.0	1.0	2.0	±0.04	DPAK, TO-220
MC78MXXB*/C	15, 18	4.0	35	2.0	1.0	2.0	±0.04	DPAK, TO-220
MC78MXXB*/C	20, 24	4.0	40	2.0	0.25	2.0	±0.04	DPAK, TO-220
MC79MXXB*/C	-(5.0, 8.0, 12, 15)	4.0	35	1.1	1.0	2.0	-0.07 to ±0.04	DPAK, TO-220

Unless otherwise noted, $T_J = 0^\circ$ to $+125^\circ\text{C}$

* $T_J = -40^\circ$ to $+125^\circ\text{C}$

** $T_A = -40^\circ$ to $+85^\circ\text{C}$

Device	V _{out}	25°C Tol. ±%	V _{in} Max	V _{in} -V _{out} Diff. Typ.	Regline Max (% V _{out})	Regload Max (% V _{out})	Typ. Temp. Coefficient mV (V _{out}) / °C	Package
--------	------------------	--------------	---------------------	--	-----------------------------------	-----------------------------------	--	---------

Fixed Voltage, 3-Terminal Regulators, 0.5 Amperes

MC33267*	5.05	2.0	40	0.58	1.0	1.0	-	D ² PAK, TO-220
----------	------	-----	----	------	-----	-----	---	----------------------------

Fixed Voltage, 3-Terminal Medium Dropout Regulators, 0.8 Amperes

MC33269-XX*	3.3, 5.0, 12	1.0	20	1.0	0.3	1.0	-	SO-8, DPAK, TO-220, SOT-223
MC34268	2.85	1.0	15	0.95	0.3	1.0	-	SO-8, DPAK

Fixed Voltage, 3-Terminal Regulators, 1.0 Amperes

MC78XXB*/C/AC	5.0, 6.0, 8.0, 12, 18	4.0/2.0	35	2.0	2.0/1.0	2.0	-0.06 to -0.22	D ² PAK, TO-220
MC7824B*/C/AC	24	4.0/2.0	40	2.0	2.0/1.0	2.0/0.4	0.125	D ² PAK, TO-220
MC79XXC/AC	-(5.0, 6.0)	4.0/2.0	35	2.0	2.0/1.0	2.0	-0.2	D ² PAK, TO-220
MC79XXC/AC	-(8.0, 12, 15, 18)	4.0/2.0	35	2.0	2.0/1.0	2.0/1.25	-0.12 to -0.06	D ² PAK, TO-220
MC7924C	-24	4.0	40	2.0	1.0	2.0	-0.04	D ² PAK, TO-220
LM340/A-XX	5.0, 12, 15	4.0/2.0	35	1.7	1.0/0.2	1.0/0.5	±0.12	TO-220

Fixed Voltage, 3-Terminal Regulators, 3.0 Amperes

MC78TXXC/AC	5.0, 8.0, 12	4.0/2.0	35	2.5	0.5	0.6	0.04	TO-220
MC78T15C/AC	15	4.0/2.0	40	2.5	0.5	0.6	0.04	TO-220
LM323/A	5.0	4.0/2.0	20	2.3	0.5/0.3	2.0/1.0	±0.2	TO-220

Unless otherwise noted, T_J = 0° to +125°C

* T_J = -40° to +125°C

** T_A = -40° to +85°C

SMPSRM

Table 2. Fixed Voltage Medium and Low Dropout Regulators

Device	V _{out}	25°C Tol. ±%	I _O (mA) Max	V _{in} Max	V _{in} -V _{out} Diff. Typ.	Regline Max (% V _{out})	Regload Max (% V _{out})	Typ. Temp. Coefficient mV (V _{out}) / °C	Package
--------	------------------	--------------	-------------------------	---------------------	--	-----------------------------------	-----------------------------------	--	---------

Fixed Voltage, Medium Dropout Regulators

MC33267*	5.05	2.0	500	40	0.58	1.0	1.0	-	D ² PAK, TO-220
MC34268	2.85	1.0	800	15	0.95	0.3	1.0		SO-8, DPAK
MC33269-XX*	3.3, 5.0, 12			20	1.0				SO-8, DPAK, TO-220, SOT-223

Fixed Voltage, Low Dropout Regulators

LM2931*/A*	5.0	5.0/3.8	100	37	0.16	1.12	1.0	±2.5	SO-8, D ² PAK, DPAK, TO-220, TO-92
LP2950C*/AC*	3.0	1.0/0.5	100	30	0.38	0.2/0.1	0.2/0.1	0.2	DPAK, TO-92
	3.3								DPAK, TO-92
	5.0								DPAK, TO-92
LP2951C*/AC*	3.0	1.0/0.5	100	28.75	0.38	0.04/0.02	0.04/0.02	±1.0	SO-8, Micro-8, DIP-8
	3.3								SO-8, Micro-8, DIP-8
	5.0								SO-8, Micro-8, DIP-8
LM2935*	5.0/5.0	5.0/5.0	500/10	60	0.45/0.55	1.0	1.0	-	TO-220, D ² PAK

Unless otherwise noted, T_J = 0° to +125°C

* T_J = -40° to +125°C

Adjustable Output

ON Semiconductor offers a broad line of adjustable output voltage regulators with a variety of output current capabilities. Adjustable voltage regulators provide users the capability of stocking a single integrated circuit

offering a wide range of output voltages for industrial and communications applications. The three-terminal devices require only two external resistors to set the output voltage.

Table 3. Adjustable Output Regulators

Device	V _{out}	I _O (mA) Max	V _{in} Max	V _{in} -V _{out} Diff. Typ.	Regline Max (% V _{out})	Regload Max (% V _{out})	Typ. Temp. Coefficient mV (V _{out}) °C	Package
Adjustable Regulators								
LM317L/B*	2.0–37	100	40	1.9	0.07	1.5	±0.35	SO–8, TO–92
LM2931C*	3.0–24	100	37	0.16	1.12	1.0	±2.5	SO–8, D ² PAK, TO–220, TO–92
LP2951C*/AC*	1.25–29	100	28.75	0.38	0.04/0.02	0.04/0.02	±1.0	SO–8, DIP–8, Micro–8
								SO–8, DIP–8, Micro–8
								SO–8, DIP–8, Micro–8
MC1723C#	2.0–37	150	38	2.5	0.5	0.2	±0.033	DIP–14, SO–14
LM317M/B*	1.2–37	500	40	2.1	0.04	0.5	±0.35	DPAK, TO–220
LM337M/B*	–(1.2–37)	500	40	1.9	0.07	1.5	±0.3	TO–220
MC33269*	1.25–19	800	18.75	1.0	0.3	0.5	±0.4	SO–8, DPAK, TO–220, SOT–223
LM317/B*	1.2–37	1500	40	2.25	0.07	1.5	±0.35	TO–220, D ² PAK
LM337/B*	–(1.2–37)	1500	40	2.3	0.07	1.5	±0.3	TO–220, D ² PAK
LM350/B*	1.2–33	3000	35	2.7	0.07	1.5	±0.5	TO–220

Unless otherwise noted, T_J = 0° to +125°C

* T_J = –40° to +125°C

T_A = 0° to +70°C

Micropower Voltage Regulators for Portable Applications

80 mA Micropower Voltage Regulator

MC78LC00H, N

$T_A = -30^\circ$ to $+80^\circ\text{C}$, SOT-89, SOT-23 5 Leads

The MC78LC00 series voltage regulators are specifically designed for use as a power source for video instruments, handheld communication equipment, and battery powered equipment.

The MC78LC00 series features an ultra-low quiescent current of 1.1 μA and a high accuracy output voltage. Each device contains a voltage reference, an error amplifier, a driver transistor and resistors for setting the output voltage. These devices are available in either SOT-89, 3 pin, or SOT-23, 5 pin, surface mount packages.

MC78LC00 Series Features:

- Low Quiescent Current of 1.1 μA Typical
- Low Dropout Voltage (220 mV at 10 mA)
- Excellent Line Regulation (0.1%)
- High Accuracy Output Voltage ($\pm 2.5\%$)
- Wide Output Voltage Range (2.0 V to 6.0 V)
- Output Current for Low Power (up to 80 mA)
- Two Surface Mount Packages (SOT-89, 3 Pin, or SOT-23, 5 Pin)

ORDERING INFORMATION

Device	Output Voltage	Operating Temperature Range	Package
MC78LC30HT1	3.0	$T_A = -30^\circ$ to $+80^\circ\text{C}$	SOT-89
MC78LC33HT1	3.3		
MC78LC40HT1	4.0		
MC78LC50HT1	5.0		
MC78LC30NTR	3.0		SOT-23
MC78LC33NTR	3.3		
MC78LC40NTR	4.0		
MC78LC50NTR	5.0		

Other voltages from 2.0 to 6.0 V, in 0.1 V increments, are available upon request. Consult factory for information.

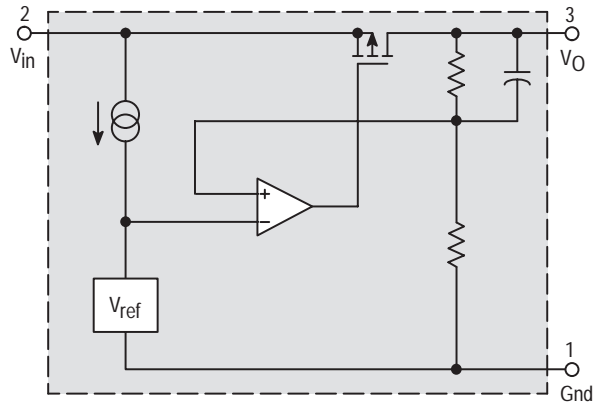

120 mA Micropower Voltage Regulator

MC78FC00H

$T_A = -30^\circ$ to $+80^\circ\text{C}$, SOT-89

The MC78FC00 series voltage regulators are specifically designed for use as a power source for video instruments, handheld communication equipment, and battery powered equipment.

The MC78FC00 series voltage regulator ICs feature a high accuracy output voltage and ultra-low quiescent current. Each device contains a voltage reference unit, an error amplifier, a driver transistor, and resistors for setting output voltage, and a current limit circuit. These devices are available in SOT-89 surface mount packages, and allow construction of an efficient, constant voltage power supply circuit.

MC78FC00 Series Features:

- Ultra-Low Quiescent Current of 1.1 μA Typical
- Ultra-Low Dropout Voltage (100 mV at 10 mA)
- Large Output Current (up to 120 mA)
- Excellent Line Regulation (0.1%)
- Wide Operating Voltage Range (2.0 V to 10 V)
- High Accuracy Output Voltage ($\pm 2.5\%$)
- Wide Output Voltage Range (2.0 V to 6.0 V)
- Surface Mount Package (SOT-89)

ORDERING INFORMATION

Device	Output Voltage	Operating Temperature Range	Package
MC78FC30HT1	3.0	$T_A = -30^\circ$ to $+80^\circ\text{C}$	SOT-89
MC78FC33HT1	3.3		
MC78FC40HT1	4.0		
MC78FC50HT1	5.0		

Other voltages from 2.0 to 6.0 V, in 0.1 V increments, are available upon request. Consult factory for information.

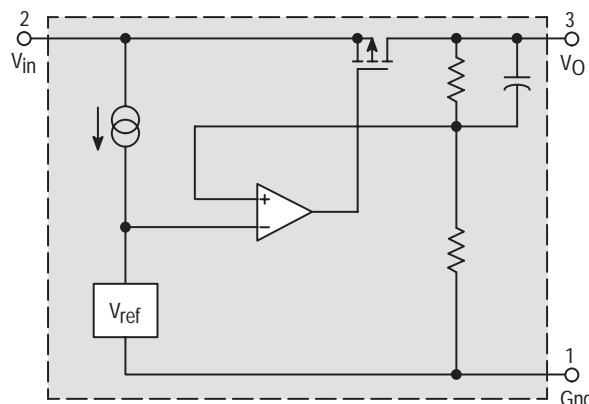

SMPSRM

Micropower Voltage Regulator for External Power Transistor

MC78BC00N

$T_A = -30^\circ$ to $+80^\circ\text{C}$, SOT-23 5 Leads

The MC78BC00 voltage regulators are specifically designed to be used with an external power transistor to deliver high current with high voltage accuracy and low quiescent current.

The MC78BC00 series are devices suitable for constructing regulators with ultra-low dropout voltage and output current in the range of several tens of mA to hundreds of mA. These devices have a chip enable function, which minimizes the standby mode current drain. Each of these devices contains a voltage reference unit, an error amplifier, a driver transistor and feedback resistors. These devices are available in the SOT-23, 5 pin surface mount packages.

These devices are ideally suited for battery powered equipment, and power sources for hand-held audio instruments, communication equipment and domestic appliances.

MC78BC00 Series Features:

- Ultra-Low Supply Current (50 μA)
- Standby Mode (0.2 μA)
- Ultra-Low Dropout Voltage (0.1 V with External Transistor and $I_O = 100\text{ mA}$)
- Excellent Line Regulation (Typically 0.1%/V)
- High Accuracy Output Voltage ($\pm 2.5\%$)

ORDERING INFORMATION

Device	Output Voltage	Operating Temperature Range	Package
MC78BC30NTR	3.0	$T_A = -30^\circ$ to $+80^\circ\text{C}$	SOT-23 5 Leads
MC78BC33NTR	3.3		
MC78BC40NTR	4.0		
MC78BC50NTR	5.0		

Other voltages from 2.0 to 6.0 V, in 0.1 V increments, are available upon request. Consult factory for information.

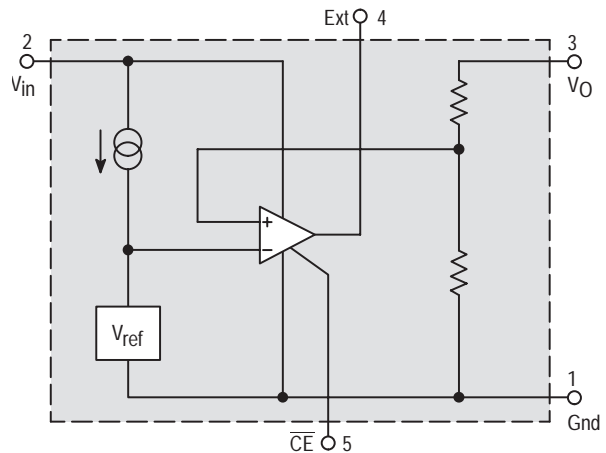

Micropower Voltage Regulators for Portable Applications (continued) Low Noise 150 mA Low Drop Out (LDO) Linear Voltage Regulator

MC78PC00

$T_A = -40^\circ$ to $+85^\circ\text{C}$, SOT-23 5 Lead Package

The MC78PC00 are a series of CMOS linear voltage regulators with high output voltage accuracy, low supply current, low dropout voltage, and high Ripple Rejection. Each of these voltage regulators consists of an internal voltage reference, an error amplifier, resistors, a current limiting circuit and a chip enable circuit.

The dynamic Response to line and load is fast, which makes these products ideally suited for use in hand-held communication equipment.

The MC78PC00 series are housed in the SOT-23 5 lead package, for maximum board space saving.

MC78PC00 Series Features:

- Ultra-Low Supply Current: typical 35 μA in ON mode with no load
- Standby Mode: typical 0.1 μA
- Low Dropout Voltage: typical 0.2 V @ $I_{\text{OUT}} = 100 \text{ mA}$
- High Ripple Rejection: typical 70 dB @ $f = 1 \text{ kHz}$
- Low Temperature-Drift Coefficient of Output Voltage: typical $\pm 100 \text{ ppm}/^\circ\text{C}$
- Excellent Line Regulation: typical 0.05%/V
- High Accuracy Output Voltage: $\pm 2.0\%$
- Fast Dynamic Response to Line and Load
- Small Package: SOT-23 5 leads
- Built-in Chip Enable circuit (CE input pin)
- Similar Pinout to the LP2980/1/2 and MIC5205

ORDERING INFORMATION

Device	Operating Temperature Range	Package
MC78PC18NTR MC78PC28NTR MC78PC30NTR MC78PC33NTR MC78PC50NTR	$T_A = -40^\circ$ to $+85^\circ\text{C}$	SOT-23 5 Leads

Other voltages are available. Consult your ON Semiconductor representative.

Block Diagram

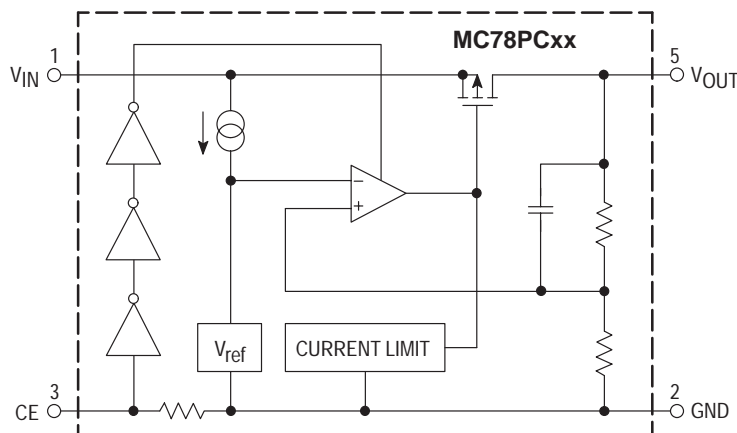

SMPSRM

Micropower Voltage Regulators for Portable Applications (continued)

Ultra Low Noise 150 mA Low Dropout Voltage Regulator with ON/OFF Control

MC33263

$T_A = -40^\circ$ to $+85^\circ\text{C}$, SOT23-L

Housed in a SOT23-L package, the MC33263 delivers up to 150 mA where it exhibits a typical 180 mV dropout. With an incredible noise level of 25 μVRMS (over 100 Hz to 100 kHz, with a 10 nF bypass capacitor), the MC33263 represents the ideal choice for sensitive circuits, especially in portable applications where noise performance and space are premium. The MC33263 also excels in response time and reacts in less than 25 μs when receiving an OFF to ON signal (with no bypass capacitor).

Thanks to a novel concept, the MC33263 accepts output capacitors without any restrictions regarding their Equivalent Series Resistance (ESR) thus offering an obvious versatility for immediate implementation.

With a typical DC ripple rejection better than -90 dB (-70 dB @ 1 kHz), it naturally shields the downstream electronics against choppy power lines.

Additionally, thermal shutdown and short-circuit protection provide the final product with a high degree of ruggedness.

MC33263 Features:

- Very Low Quiescent Current 170 μA (ON, no load), 100 nA (OFF, no load)
- Very Low Dropout Voltage, typical value is 137 mV at an output current of 100 mA

- Very Low Noise with external bypass capacitor (10 nF), typically 25 μVrms over 100 Hz to 100 kHz
- Internal Thermal Shutdown
- Extremely Tight Line Regulation typically -90 dB
- Ripple Rejection -70 dB @ 1 kHz
- Line Transient Response: 1 mV for $\Delta V_{in} = 3\text{ V}$
- Extremely Tight Load Regulation, typically 20 mV at $\Delta I_{out} = 150\text{ mA}$
- Multiple Output Voltages Available
- Logic Level ON/OFF Control (TTL-CMOS Compatible)
- ESR can vary from 0 to 3 Ω
- Functionally and Pin Compatible with TK112xxA/B Series

ORDERING INFORMATION

Device	Operating Temperature Range	Package
MC33263NW-28R2 MC33263NW-30R2 MC33263NW-32R2 MC33263NW-33R2 MC33263NW-38R2 MC33263NW-40R2 MC33263NW-47R2 MC33263NW-50R2	$T_A = -40^\circ$ to $+85^\circ\text{C}$	SOT23-L

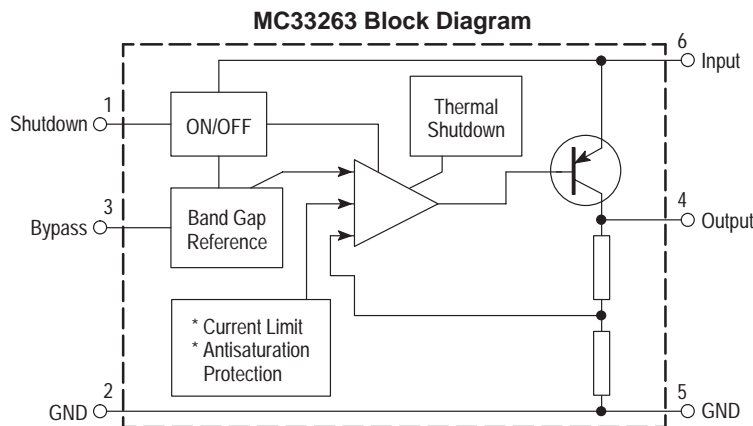

Micropower Voltage Regulators for Portable Applications (continued)

Micropower smallCAP™ Voltage Regulators with On/Off Control

MC33264D, DM

T_A = -40° to +85°C, SO-8, Micro-8

The MC33264 series are micropower low dropout voltage regulators available in SO-8 and Micro-8 surface mount packages and a wide range of output voltages. These devices feature a very low quiescent current (100 µA in the ON mode; 0.1 µA in the OFF mode), and are capable of supplying output currents up to 100 mA. Internal current and thermal limiting protection is provided. They require only a small output capacitance for stability.

Additionally, the MC33264 has either active HIGH or active LOW control (Pins 2 and 3) that allows a logic level signal to turn-off or turn-on the regulator output.

Due to the low input-to-output voltage differential and bias current specifications, these devices are ideally suited for battery powered computer, consumer, and industrial equipment where an extension of useful battery life is desirable.

MC33264 Features:

- Low Quiescent Current (0.3 µA in OFF Mode; 95 µA in ON Mode)
- Low Input-to-Output Voltage Differential of 47 mV at 10 mA, and 131 mV at 50 mA
- Multiple Output Voltages Available
- Extremely Tight Line and Load Regulation

- Stable with Output Capacitance of Only 0.22 µF for 4.0 V, 4.75 V and 5.0 V Output Voltages
0.33 µF for 2.8 V, 3.0 V, 3.3 V and 3.8 V Output Voltages
- Internal Current and Thermal Limiting
- Logic Level ON/OFF Control
- Functionally Equivalent to TK115XXMC and LP2980

ORDERING INFORMATION

Device	Operating Temperature Range	Package
MC33264D-2.8 MC33264D-3.0 MC33264D-3.3 MC33264D-3.8 MC33264D-4.0 MC33264D-4.75 MC33264D-5.0	T _A = -40° to +85°C	SO-8
MC33264DM-2.8 MC33264DM-3.0 MC33264DM-3.3 MC33264DM-3.8 MC33264DM-4.0 MC33264DM-4.75 MC33264DM-5.0		Micro-8

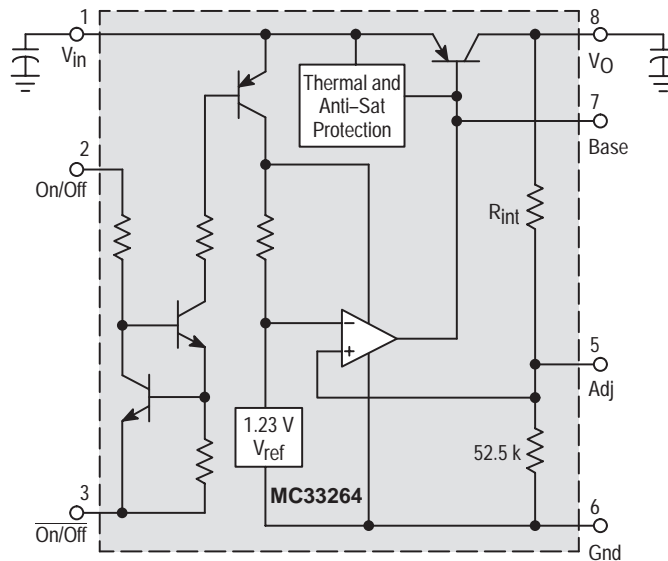

SMPSRM

Micropower Voltage Regulators for Portable Applications (continued)
Ultra Low–Noise Low Dropout Voltage Regulator
with 1V ON/OFF Control

MC33761

$T_A = -40^\circ$ to $+85^\circ\text{C}$, TSOP–5

The MC33761 is a Low DropOut (LDO) regulator featuring excellent noise performances. Thanks to its innovative concept, the circuit reaches an incredible $40\mu\text{VRMS}$ noise level *without* an external bypass capacitor. Housed in a small SOT–23 5 leads–like package, it represents the ideal designer’s choice when space and noise are at premium.

The absence of external bandgap capacitor unleashes the response time to a wake–up signal and makes it stay within $40\mu\text{s}$ (in repetitive mode), pushing the MC33761 as a natural candidate in portable applications.

The MC33761 also hosts a novel architecture which prevents excessive undershoots when the regulator is the seat of fast transient bursts, as in any bursting systems.

Finally, with a static line regulation better than -75dB , it naturally shields the downstream electronics against choppy lines.

MC33761 Features:

- Ultra low–noise: $150\text{nV}/\sqrt{\text{Hz}}$ @ 100Hz , $40\mu\text{VRMS}$ $100\text{Hz} - 100\text{kHz}$ typical, $I_{\text{out}} = 60\text{mA}$, $C_{\text{o}} = 1\mu\text{F}$
- Fast response time from OFF to ON: $40\mu\text{s}$ typical at a 200Hz repetition rate

- Ready for 1V platforms: ON with a 900mV high level
- Nominal output current of 80mA with a 100mA peak capability
- Typical dropout of 90mV @ 30mA , 160mV @ 80mA
- Ripple rejection: 70dB @ 1kHz
- 1.5% output precision @ 25°C
- Thermal shutdown
- V_{out} available from 2.5V to 5.0V

Applications:

- Noise sensitive circuits: VCOs RF stages etc.
- Bursting systems (TDMA phones)
- All battery operated devices

ORDERING INFORMATION

Device	Operating Temperature Range	Package
MC33761SNT1–25 MC33761SNT1–28 MC33761SNT1–30	$T_A = -40^\circ$ to $+85^\circ\text{C}$	TSOP–5

Simplified Block Diagram

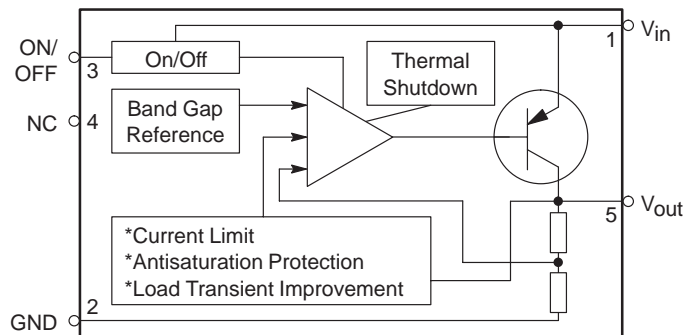

Micropower Voltage Regulators for Portable Applications (continued)

Dual Ultra Low–Noise Low Dropout Voltage Regulator with 1V ON/OFF Control

MC33762

$T_A = -40^\circ$ to $+85^\circ\text{C}$, Micro8

The MC33762 is a dual Low DropOut (LDO) regulator featuring excellent noise performances. Thanks to its innovative concept, the circuit reaches an incredible $40\mu\text{VRMS}$ noise level *without* an external bypass capacitor. Housed in a small $\mu 8$ package, it represents the ideal designer's choice when space and noise are at premium.

The absence of external bandgap capacitor unleashes the response time to a wake-up signal and makes it stay within $40\mu\text{s}$, pushing the MC33762 as a natural candidate in portable applications.

The MC33762 also hosts a novel architecture which prevents excessive undershoots when the regulator is the seat of fast transient bursts, as in any bursting systems.

Finally, with a static line regulation better than -75dB , it naturally shields the downstream electronics against choppy lines.

MC33762 Features:

- Nominal output current of 80mA with a 100mA peak capability
- Ultra low–noise: $150\text{nV}/\sqrt{\text{Hz}}$ @ 100Hz, $40\mu\text{VRMS}$ 100Hz – 100kHz typical, $I_{\text{out}} = 60\text{mA}$, $C_{\text{o}} = 1\mu\text{F}$
- Fast response time from OFF to ON: $40\mu\text{s}$ typical
- Ready for 1V platforms: ON with a 900mVhigh level
- Typical dropout of 90mV @ 30mA, 160mV @ 80mA
- Ripple rejection: 70dB @ 1kHz
- 1.5% output precision @ 25°C
- Thermal shutdown
- Vout available from 2.5V to 5.0V

Applications:

- Noise sensitive circuits: VCOs RF stages etc.
- Bursting systems (TDMA phones)
- All battery operated devices

ORDERING INFORMATION

Device	Operating Temperature Range	Package
MC33762DM–2525R2 MC33762DM–2828R2 MC33762DM–3030R2	$T_A = -40^\circ$ to $+85^\circ\text{C}$	Micro8

SMPSRM

Simplified Block Diagram

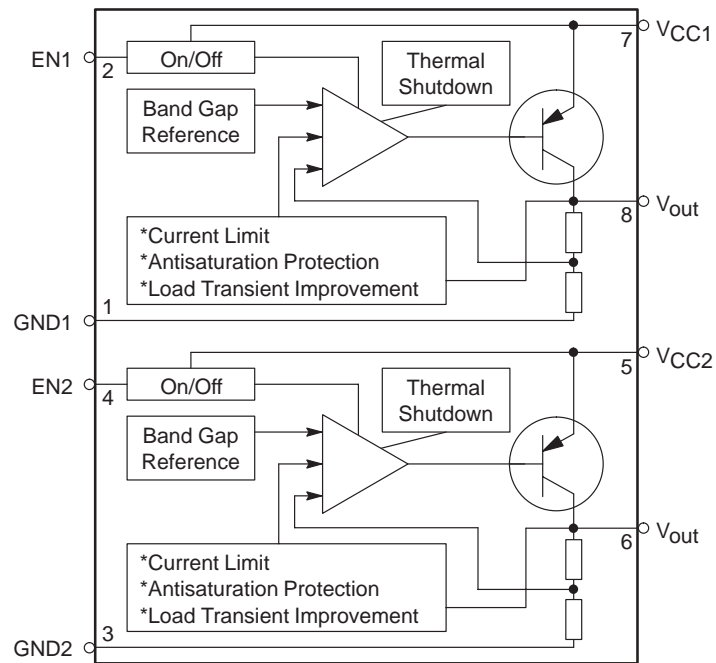

Special Voltage Regulators

Table 4. Voltage Regulators

Function	Features	Package	Device
Multifunction Very Low Dropout Voltage Regulator	A monolithic integrated 5.0 V voltage regulator with a very low dropout and additional functions such as power-on reset and input voltage sense. It is designed for supplying the micro-computer controlled systems especially in automotive applications.	DIP-8, SO-8	L4949
Low Dropout Voltage Regulator	Fixed and adjustable positive output voltage regulators which maintain regulation with very low input-to-output voltage differential.	TO-92, TO-220, DPAK, D ² PAK, SO-8	LM2931 Series
Low Dropout Voltage Regulator	Low voltage differential regulator featuring dual positive 5.0 V outputs; switched currents in excess of 750 mA and 10 mA standby current. Fixed quiescent current is less than 3.0 mA.	TO-220, D ² PAK	LM2935
Low Dropout Voltage Regulator	Positive 5.0 V, 500 mA regulator with on-chip power-up-reset circuit with externally programmable delay, current limit, and thermal shutdown.	TO-220, D ² PAK	MC33267
Low Dropout Voltage Regulator	Positive 3.3 V, 5.0 V, 12 V, 800 mA regulator.	SO-8, DPAK, SOT-223, TO-220	MC33269
Low Dropout Voltage Regulator	Positive regulator with 5 outputs fixed 2.8 V and 13 V.	TSSOP-16	MC33765

Special Regulators

Voltage Regulator/Supervisory

Table 5. Voltage Regulator/Supervisory

Device	V _{out} (V)		I _O (mA) Max	V _{in} (V)		Regline (mV) Max	Regload (mV) Max	T _A (°C)	Suffix/Package
	Min	Max		Min	Max				
MC34160	4.75	5.25	100	7.0	40	40	50	0 to +70	DIP-16, SO-16L
MC33160								-40 to +85	
MC33267	4.9	5.2	500	6.0	26	50	50	-40 to +105	TO-220, D ² PAK

* These ICs are intended for powering cellular phone GaAs power amplifiers and can be used for other portable applications as well.

SMPSRM

Voltage Regulator/Supervisory (continued)

Microprocessor Voltage Regulator and Supervisory Circuit

MC34160P, DW

$T_A = 0^\circ$ to $+70^\circ\text{C}$, DIP-16, SO-16L

MC33160P, DW

$T_A = -40^\circ$ to $+85^\circ\text{C}$, DIP-16, SO-16L

The MC34160 series is a voltage regulator and supervisory circuit containing many of the necessary monitoring functions required in microprocessor based systems. It is specifically designed for appliance and industrial applications offering the designer a cost effective solution with minimal external components. These integrated circuits feature a 5.0 V, 100 mA regulator with short circuit current limiting, pinned out 2.6 V bandgap reference, low voltage

reset comparator, power warning comparator with programmable hysteresis, and an uncommitted comparator ideally suited for microprocessor line synchronization.

Additional features include a chip disable input for low standby current, and internal thermal shutdown for over temperature protection.

These devices are contained in a 16 pin dual-in-line heat tab plastic package for improved thermal conduction.

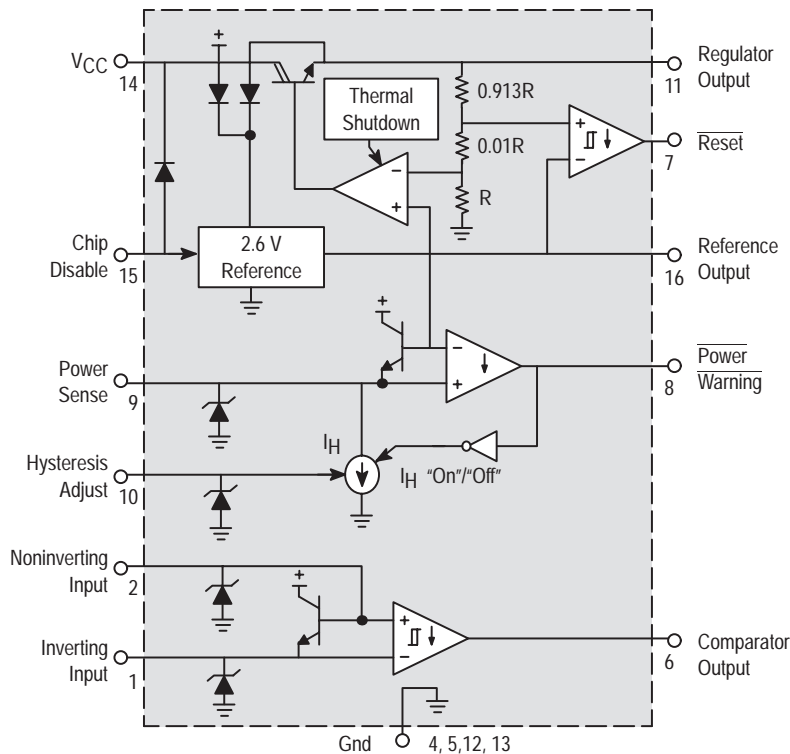

Voltage Regulator/Supervisory (continued)

Low Dropout Regulator

MC33267T, TV

$T_J = -40^\circ$ to $+105^\circ\text{C}$, TO-220 5 Leads, D²PAK 5 Leads

The MC33267 is a positive fixed 5.0 V regulator that is specifically designed to maintain proper voltage regulation with an extremely low input-to-output voltage differential. This device is capable of supplying output currents in excess of 500 mA and contains internal current limiting and thermal shutdown protection. Also featured is an on-chip power-up reset circuit that is ideally suited for use in microprocessor based systems. Whenever the regulator output voltage is below nominal, the reset output

is held low. A programmable time delay is initiated after the regulator has reached its nominal level and upon timeout, the reset output is released.

Due to the low dropout voltage specifications, the MC33267 is ideally suited for use in battery powered industrial and consumer equipment where an extension of useful battery life is desirable. This device is contained in an economical five lead TO-220 type package.

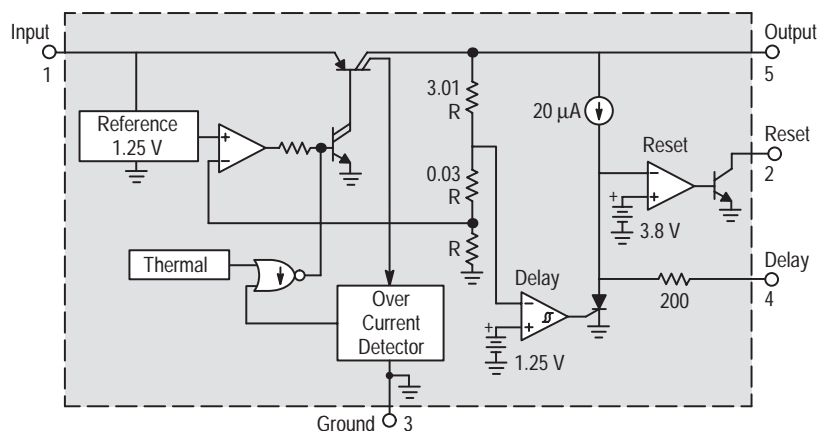

SMPSRM

Voltage Regulator/Supervisory (continued)

Very Low Dropout Regulator

L4949N, D

$T_J = -40^\circ$ to $+125^\circ\text{C}$, DIP-8, SO-8

The L4949 is a monolithic integrated 5.0 V voltage regulator with a very low dropout and additional functions such as power-on reset and input voltage sense.

It is designed for supplying the micro-computer controlled systems especially in automotive applications.

- Operating DC Supply Voltage Range 5.0 V to 28 V
- Transient Supply Voltage Up to 40 V
- Extremely Low Quiescent Current in Standby Mode
- High Precision Standby Output Voltage 5.0 V $\pm 1\%$
- Output Current Capability Up to 100 mA
- Very Low Dropout Voltage Less Than 0.4 V
- Reset Circuit Sensing The Output Voltage
- Programmable Reset Pulse Delay With External Capacitor
- Voltage Sense Comparator
- Thermal Shutdown and Short Circuit Protections

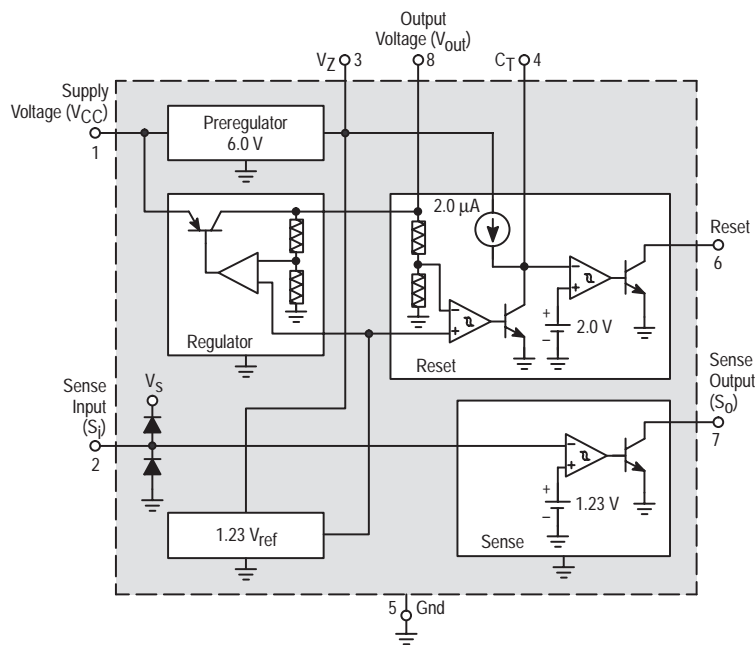

Voltage Regulator/Supervisory (continued)

Very Low Dropout/Ultra Noise 5 Outputs Voltage Regulator

MC33765

$T_A = -40^\circ$ to $+85^\circ\text{C}$, TSSOP16

The MC33765 is an ultra low noise, very low dropout voltage regulator with five independent outputs which is available in TSSOP 16 surface mount package.

Two versions are available: 2.8 V or 3.0 V. The voltage of all five outputs is 2.8 V or 3.0 V typical but each output is capable of supplying different currents up to 150 mA for output 4. The device features a very low dropout voltage (0.11 V typical for maximum output current), very low quiescent current (5.0 mA maximum in OFF mode, 130 mA typical in ON mode) and one of the output (output 3) exhibits a very low noise level which allows the driving of noise sensitive circuitry. Internal current and thermal limiting protections are provided.

Additionally, the MC33765 has an independent Enable input pin for each output. It includes also a common Enable pin to shutdown the complete circuit when not used. *The Common Enable pin has the highest priority over the five independent Enable input pins.*

The voltage regulators VR1, VR2 and VR3 have a common input voltage pin V_{CC1} .

The other voltage regulators VR4 and VR5 have a common input voltage pin V_{CC2} .

MC33765 Features:

- Five Independent Outputs at 2.8 V or 3.0 V Typical
- Internal Trimmed Voltage Reference
- V_{Out} Tolerance $\pm 3.0\%$ at 25°C
- Enable Input Pin (Logic-Controlled Shutdown) for Each of the Five Outputs
- Common Enable Pin to Shutdown the Whole Circuit
- Very Low Dropout Voltage (0.11 V Typical for Output 1, 2, 3 and 5; 0.17 V Typical for Output 4 at Maximum Current)
- Very Low Quiescent Current (Maximum 5.0 μA in OFF Mode, 130 μA Typical in ON Mode)
- Ultra Low Noise for VR3 (30 μV RMS Max, $100\text{ Hz} < f < 100\text{ kHz}$)
- Internal Current and Thermal Limit
- 100 nF for VR1, VR2, VR4 and VR5 and 1.0 μF for VR3 for Stability
- Supply Voltage Rejection: 60 dB (Typical) @ $f = 1.0\text{ kHz}$

ORDERING INFORMATION

Device	Voltage Version	Operating Temperature Range	Package
MC33765DTB, R2	2.8 V Fixed	$T_A = -40^\circ$ to $+85^\circ\text{C}$	TSSOP-16
MC33765DTB-30, R2	3.0 V Fixed		

SMPSRM

Simplified Block Diagram

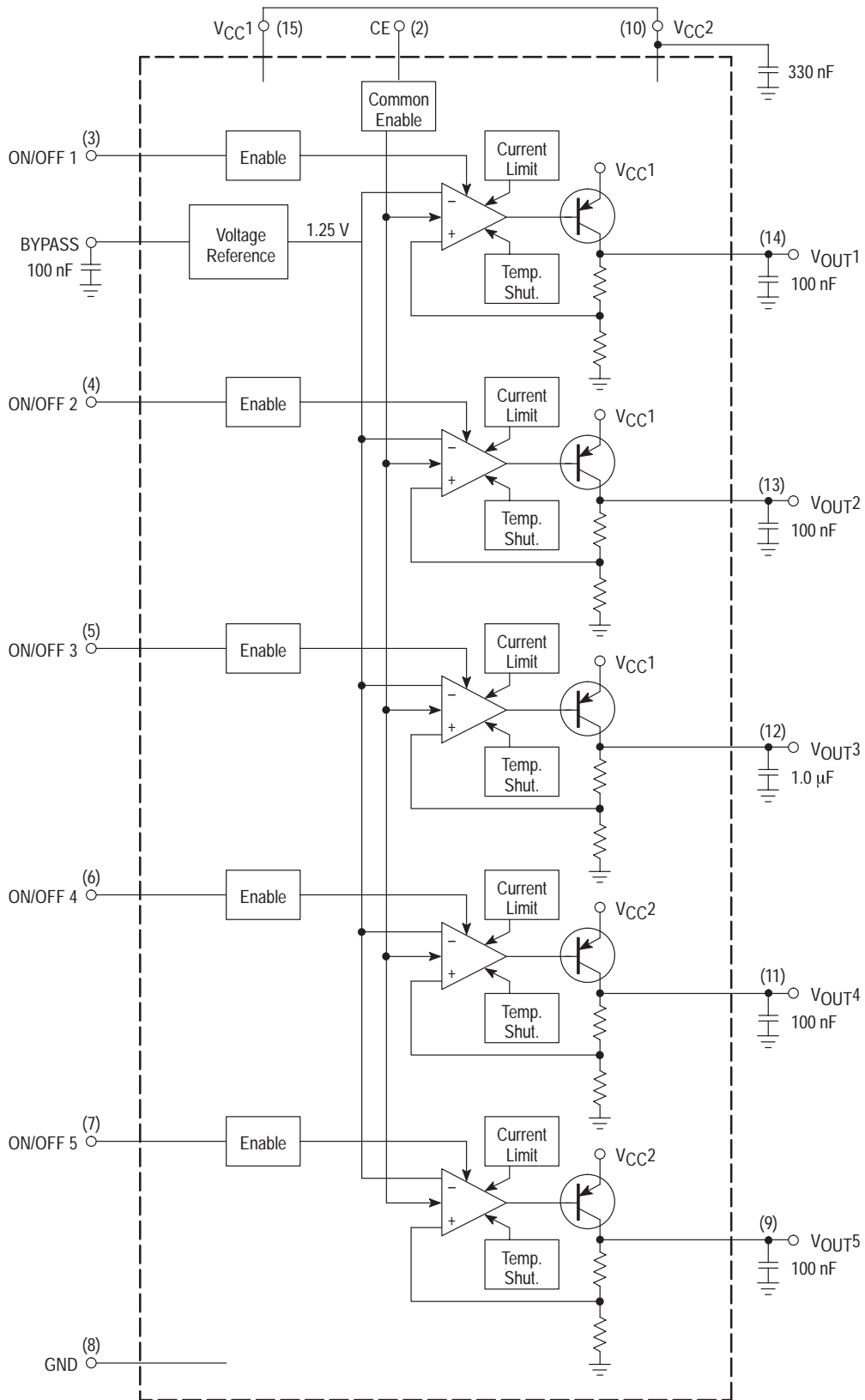

Drivers

	Page
MOSFET/IGBT Drivers	116
Dedicated Drivers	118
Power Controllers	119

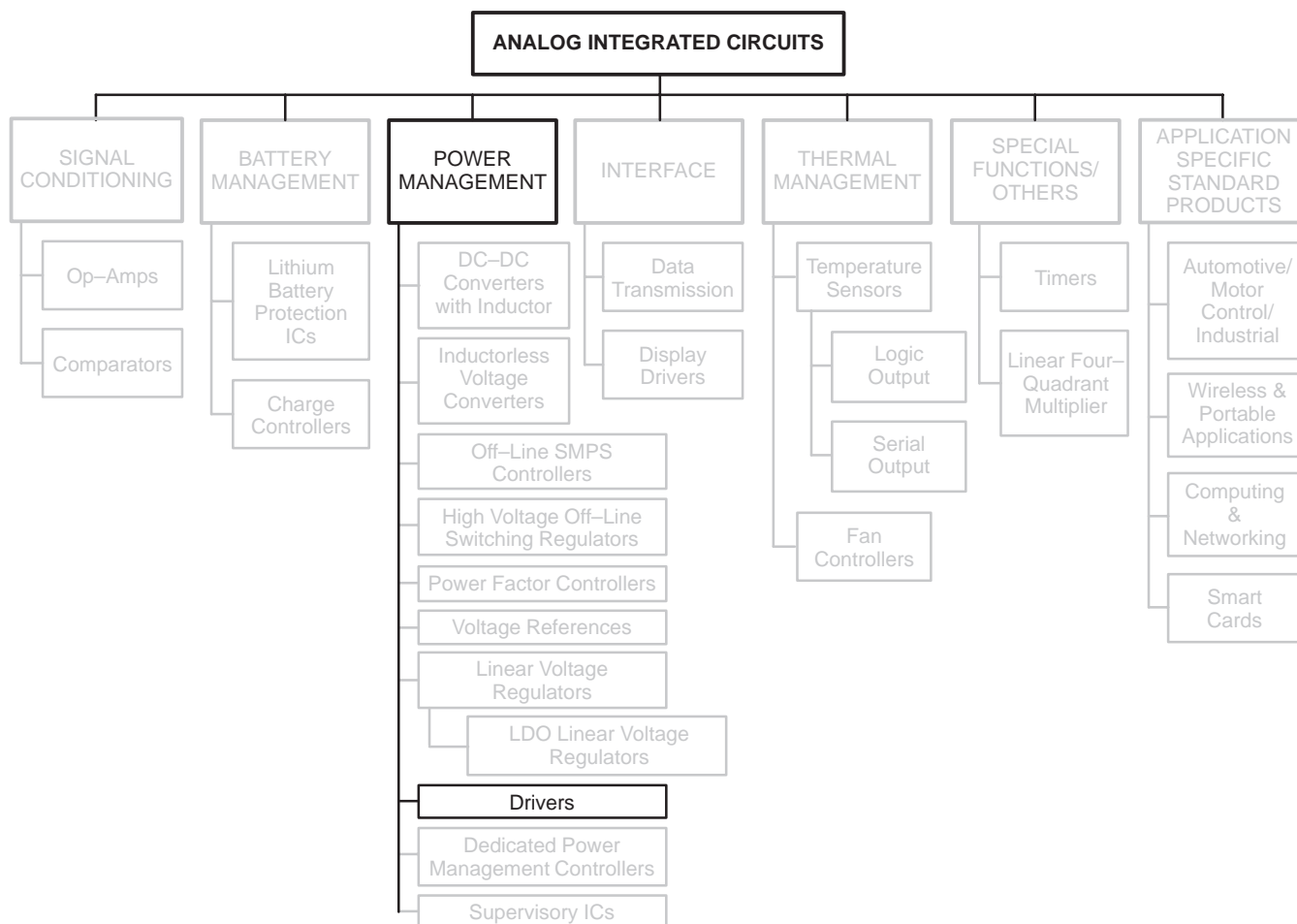

MOSFET/IGBT Drivers

High Speed Dual Drivers

(Inverting)

MC34151P, D

$T_A = 0^\circ$ to $+70^\circ\text{C}$, DIP-8, SO-8

MC33151P, D

$T_A = -40^\circ$ to $+85^\circ\text{C}$, DIP-8, SO-8

These two series of high speed dual MOSFET driver ICs are specifically designed for applications requiring low current digital circuitry to drive large capacitive loads at high slew rates. Both series feature a unique undervoltage lockout function which puts the outputs in a defined low state in an undervoltage condition. In addition, the low “on” state resistance of these bipolar drivers allows significantly higher output currents at lower supply voltages than with competing drivers using CMOS technology.

(Noninverting)

MC34152P, D

$T_A = 0^\circ$ to $+70^\circ\text{C}$, DIP-8, SO-8

MC33152P, D

$T_A = -40^\circ$ to $+85^\circ\text{C}$, DIP-8, SO-8

The MC34151 series is pin-compatible with the MMH0026 and DS0026 dual MOS clock drivers, and can be used as drop-in replacements to upgrade system performance. The MC34152 noninverting series is a mirror image of the inverting MC34151 series.

These devices can enhance the drive capabilities of first generation switching regulators or systems designed with CMOS/TTL logic devices. They can be used in dc-to-dc converters, motor controllers, capacitor charge pump converters, or virtually any other application requiring high speed operation of power MOSFETs.

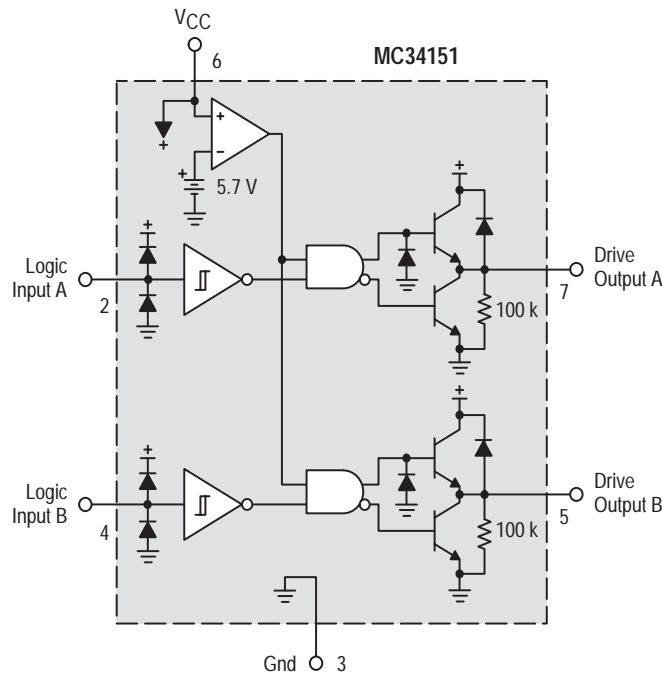

MOSFET/IGBT Drivers (continued)

Single IGBT Driver

MC33153P, D

T_A = -40° to +105°C, DIP-8, SO-8

The MC33153 is specifically designed to drive the gate of an IGBT used for ac induction motors. It can be used with discrete IGBTs and IGBT modules up to 100A.

Typical applications are ac induction motor control, brushless dc motor control, and uninterruptable power supplies.

These devices are available in dual-in-line and surface mount packages and include the following features:

- High Current Output Stage : 1.0 A Source – 2.0 A Sink
- Protection Circuits for Both Conventional and SenseIGBTs
- Current Source for Blanking Timing
- Protection Against Overcurrent and Short Circuit
- Undervoltage Lockout Optimized for IGBT's
- Negative Gate Drive Capability

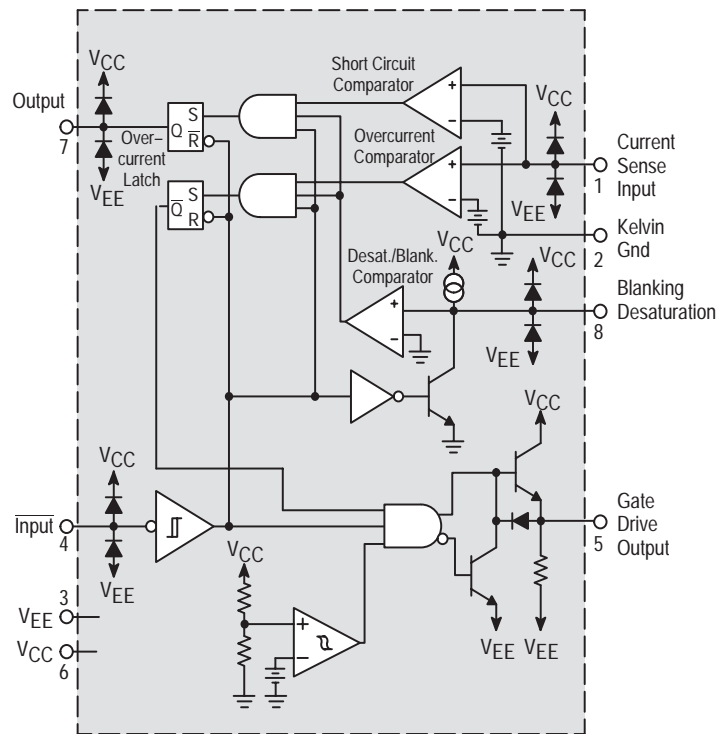

Dedicated Drivers

Half Bridge Controller and Driver for Industrial Linear Tubes

MC33157DW

The MC33157DW includes the oscillator circuit and two output channels to control a half-bridge power stage. One of the channels is ground-referenced. The second one is floating to provide a bootstrap operation for the high side switch.

Dedicated Driver for Industrial Linear Tubes

- Main oscillator is current controlled, making it easy to set up by a single external resistor. On top of that, such a feature is useful to implement a dimming function by frequency shift.
- Filament preheating time control built-in.
- The strike sequence is controllable by external passive components, the resonant frequency being independently adjustable. This frequency can be made different from the preheating and the steady state values. A frequency sweep between two

defined values makes this IC suitable for any series resonant topologies.

- Dedicated internal comparator provides an easy lamp strike detection implementation.
- Digital RESET pin provides a fast reset of the system (less than 10 μ s). Both output Mosfet are set to "OFF" state when RESET is zero.
- Adjustable dead time makes the product suitable for any snubber capacitor and size of MOSFET used as power switches.
- Designed to be used with standard setting capacitors ≤ 470 nF.
- A voltage reference, derived from the internal bandgap, is provided for external usage. This voltage is 100% trimmed at probe level yielding a 2% tolerance over the temperature range.

ORDERING INFORMATION

Device	Tested Operating Temperature Range	Package
MC33157DW	$T_A = -40^\circ$ to $+85^\circ\text{C}$	Plastic SO-16L

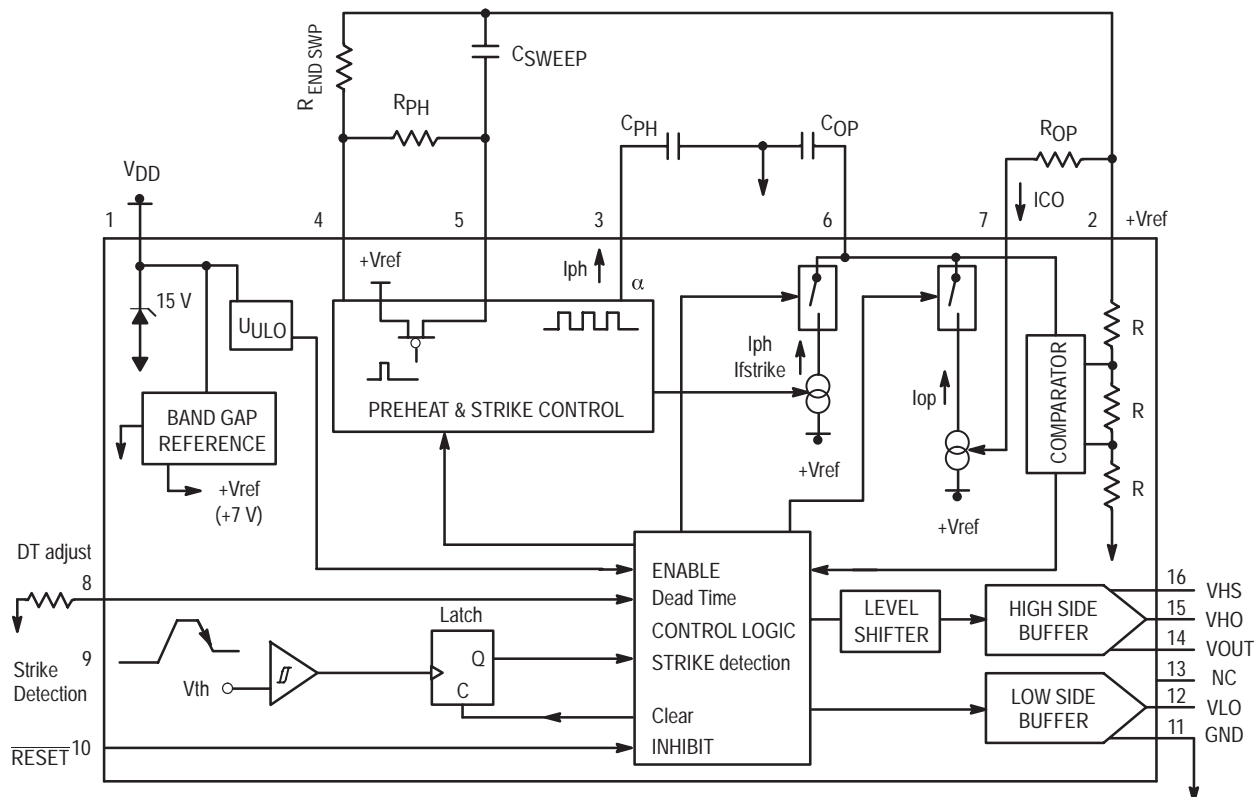

Power Controllers

An assortment of battery and ac line-operated control ICs for specific applications are shown. They are designed to enhance system performance and reduce complexity in a wide variety of control applications.

Zero Voltage Switch

CA3059

$T_A = -40^\circ$ to $+85^\circ\text{C}$, DIP-14

This device is designed for thyristor control in a variety of ac power switching applications for ac input voltages of 24 V, 120 V, 208/230 V, and 227 V @ 50/60 Hz.

- **Limiter-Power Supply** – Allows operation directly from an ac line.
- **Differential “On”/“Off” Sensing Amplifier** – Tests for condition of external sensors or input command signals. Proportional control capability or hysteresis may be implemented.
- **Zero-Crossing Detector** – Synchronizes the output pulses to the zero voltage point of the ac cycle. Eliminates RFI when used with resistive loads.
- **Triac Drive** – Supplies high current pulses to the external power controlling thyristor.
- **Protection Circuit** – A built-in circuit may be actuated, if the sensor opens or shorts, to remove the drive circuit from the external triac.
- **Inhibit Capability** – Thyristor firing may be inhibited by the action of an internal diode gate.
- **High Power DC Comparator Operation** – Operation in this mode is accomplished by connecting Pin 7 to 12 (thus overriding the action of the zero-crossing detector).

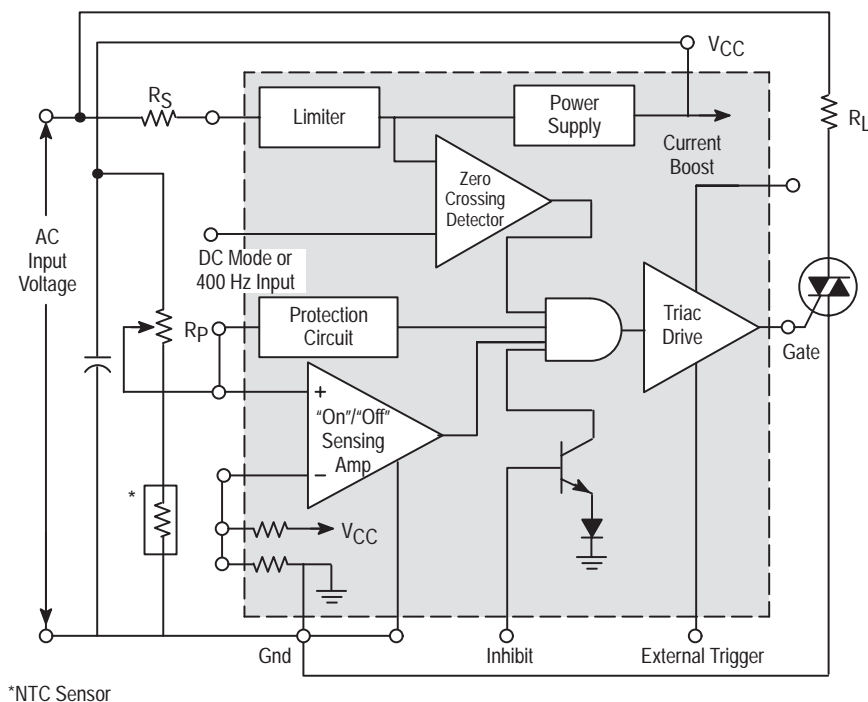

SMPSRM

Power Controllers (continued)

Zero Voltage Controller

UAA2016P, D

$T_A = -20^\circ$ to $+85^\circ\text{C}$, DIP-8, SO-8

The UAA2016 is designed to drive triacs with the Zero Voltage technique which allows RFI free power regulation of resistive loads. Operating directly on the ac power line, its main application is the precision regulation of electrical heating systems such as panel heaters or irons.

A built-in digital sawtooth waveform permits proportional temperature regulation action over a $\pm 1^\circ\text{C}$ band around the set point. For energy savings there is a programmable temperature reduction function, and for security, a sensor failsafe inhibits output pulses when the sensor connection is broken. Preset temperature (i.e., defrost) application is also possible. In applications where

high hysteresis is needed, its value can be adjusted up to 5°C around the set point. All these features are implemented with a very low external component count.

- Zero Voltage Switch for Triacs, up to 2.0 kW (MAC212A8)
- Direct AC Line Operation
- Proportional Regulation of Temperature over a 1°C Band
- Programmable Temperature Reduction
- Preset Temperature (i.e., Defrost)
- Sensor Failsafe
- Adjustable Hysteresis
- Low External Component Count

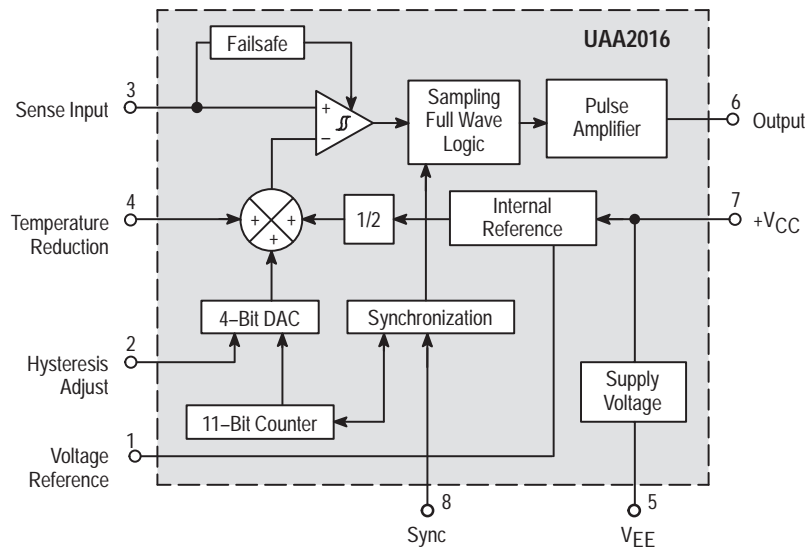

Dedicated Power Management Controllers

In Brief . . .

Dedicated power management controllers are designed and developed for specific applications like PDAs, Smart Card-based systems, or cellular phones. These controllers are utilizing mixed-signal processes such as SMARTMOS™ for improved high performance and precision characteristics. They have a high integration level and may integrate multiple analog or digital functions such as LDO voltage regulators, DC-DC converters, Analog-to-Digital converters, latches, and multiple gates.

	Page
GaAs Power Amplifier Support IC	122
Versatile 6 Regulator Power Management Circuit for Cellular Subscriber Terminal	123

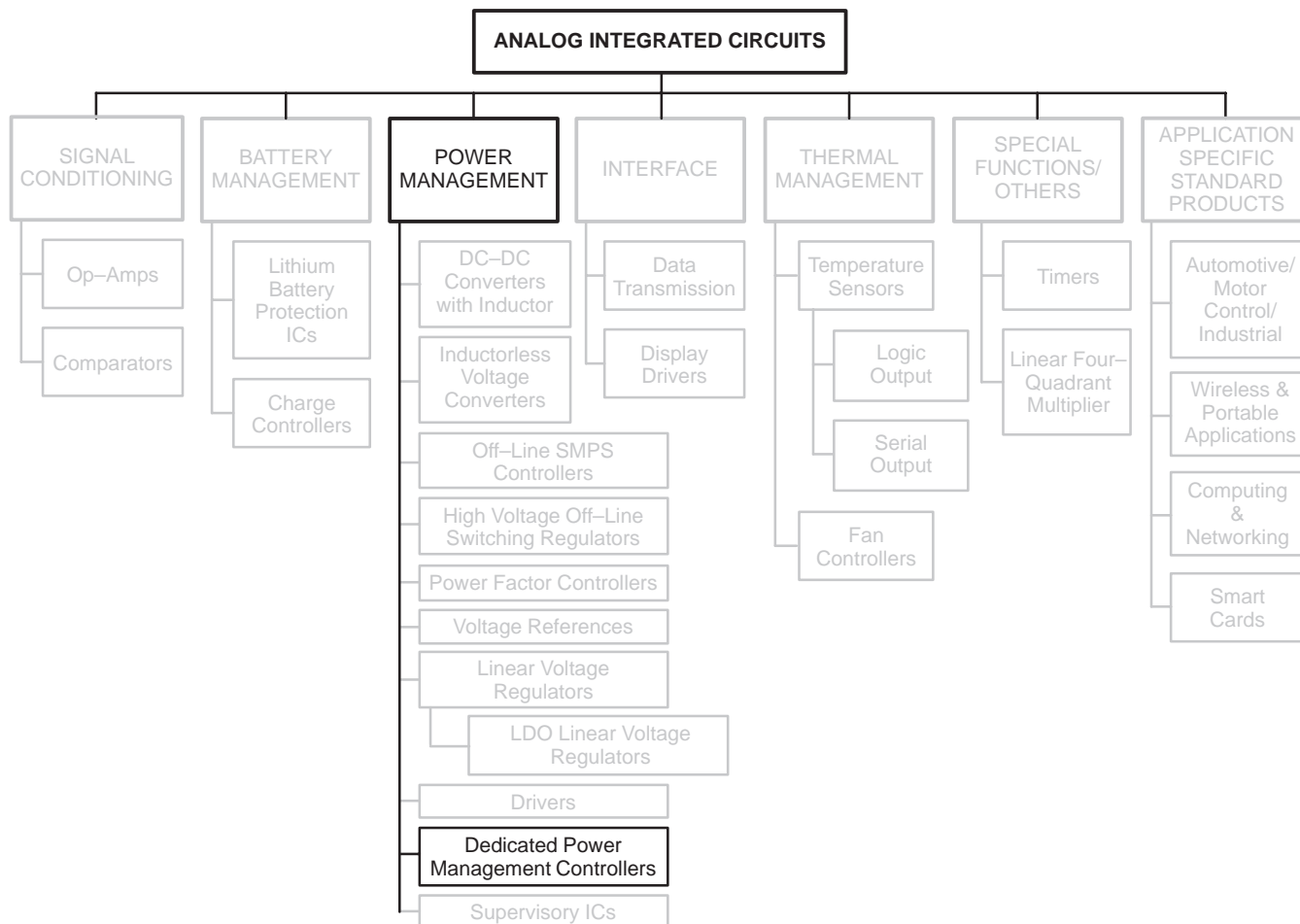

GaAs Power Amplifier Support IC

MC33169DTB

T_A = -40° to +85°C, TSSOP-14

The MC33169 is a support IC for GaAs Power Amplifier Enhanced FETs used in hand portable telephones such as GSM, PCN and DECT. This device provides negative voltages for full depletion of Enhanced MESFETs as well as a priority management system of drain switching, ensuring that the negative voltage is always present before turning “on” the Power Amplifier. Additional features include an idle mode input and a direct drive of the N-Channel drain switch transistor.

This product is available in one version, -4.0 V. The

-4.0 V version is intended for supplying RF modules for GSM and DCS1800 applications.

- Negative Regulated Output for Full Depletion of GaAs MESFETs
- Drain Switch Priority Management Circuit
- CMOS Compatible Inputs
- Idle Mode Input (Standby Mode) for Very Low Current Consumption
- Output Signal Directly Drives N-Channel FET
- Low Startup and Operating Current

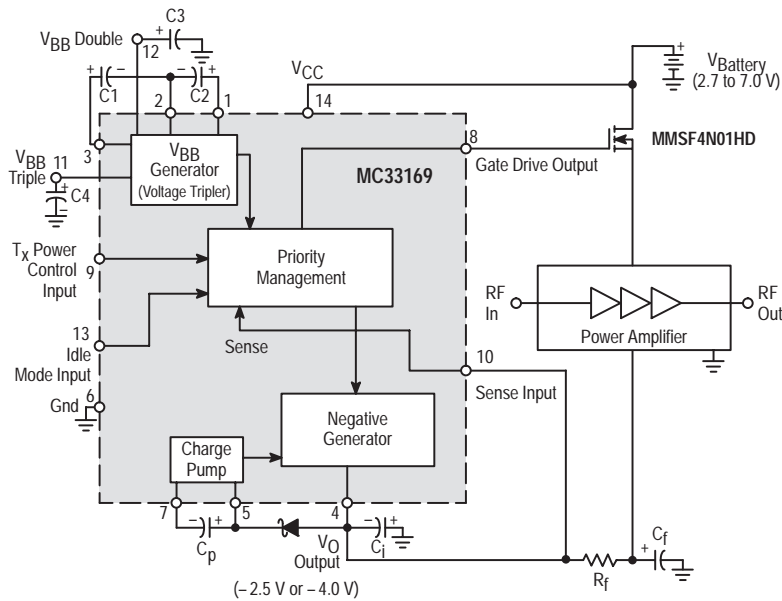

Versatile 6 Regulator Power Management Circuit for Cellular Subscriber Terminal

MC33283

$T_A = -20^{\circ}\text{C}$ to $+70^{\circ}\text{C}$, TQFP-32

The MC33283 is a complete power management solution for portable devices such as telephone handsets, two-way radios, etc. Thanks to its large scale integration, the device offers up to seven Low DropOut regulators (LDO), two of them delivering a voltage higher than the battery's.

Despite the presence of an internal charge pump, the overall noise specification makes the circuit an ideal candidate where noise is an important feature. Outputs deliver $40\mu\text{VRMS}$ typical (10–100kHz) at nominal output current.

With a 50dB ripple rejection under 10kHz, the circuit naturally shields the downstream electronics against DC choppy lines. This parameter guarantees a clean operation for battery operated devices.

Finally, housed in a compact Thin Quad Flat Pack TQFP-32 package, the MC33283 gathers all the features necessary to power future portable radios.

- 6 regulated outputs:
 - 2.85V, four outputs: 10–135mA
 - 4.75V @ 15mA
 - 5.0V @ 20mA
- Low-noise: $40\mu\text{VRMS}$ at nominal output levels (10Hz–100kHz)
- Ultra-low reverse current in OFF mode (200nA typical)
- Two-mode regulator: output 5 switches from 3 to 5V with SEL pin activated
- Thermal shutdown for a rugged and reliable operation
- All outputs are short-circuit proof

ORDERING INFORMATION

Device	Operating Temperature Range	Package
MC33283FTB28,R2	-20°C to $+70^{\circ}\text{C}$	TQFP-32

Simplified Block Diagram

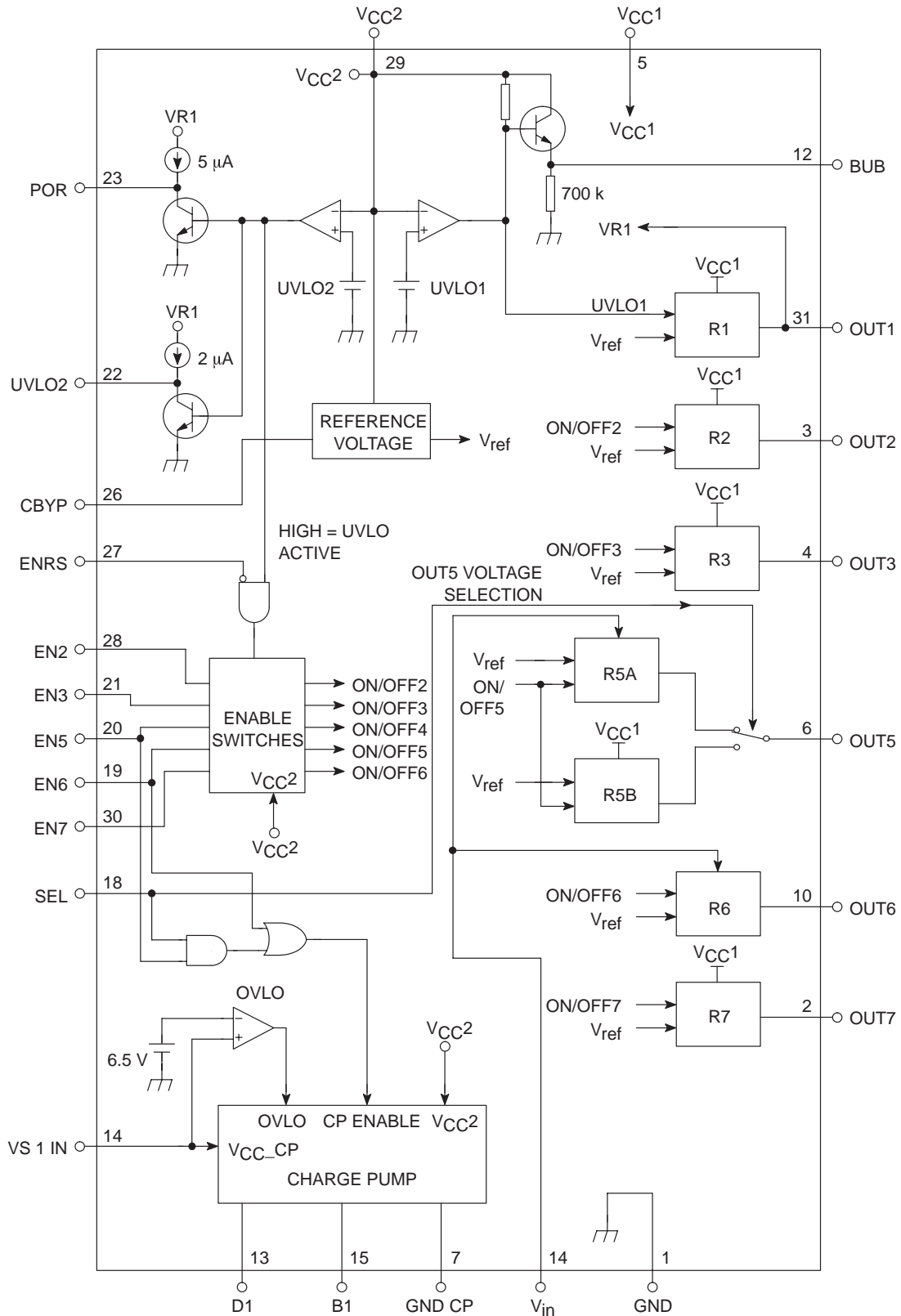

Supervisory ICs

In Brief . . .

Power supplies, MCU-based systems, industrial controls, computer systems and many other products, portable or not, are requiring system management functions which monitor voltages to ensure proper system operation.

These circuits monitor critical circuit conditions and report any violations of prescribed limits to a microprocessor. The microprocessor will then take appropriate action such as storing data before executing a graceful shutdown.

ON Semiconductor offers a wide variety of voltage supervisory circuits (Undervoltage or Overvoltage) designed for use where precise voltage limits or windows are required for reliable system operation.

Newer supervisory circuits have utilized CMOS technology and miniature surface mount packages (SOT23-5 leads) to reduce the current consumption and the PCB board area. This makes them particularly suited for battery-powered applications.

	Page
Supervisory Circuits	126
Overvoltage Crowbar Sensing Circuit	126
Over/Undervoltage Protection Circuit	127
Micropower Undervoltage Sensing Circuits	128
Micropower Undervoltage Sensing Circuits with Programmable Output Delay	129
Undervoltage Sensing Circuit	130
Universal Voltage Monitor	131
3-Pin Microprocessor Reset Monitors	132
Under Voltage Detector Series	133

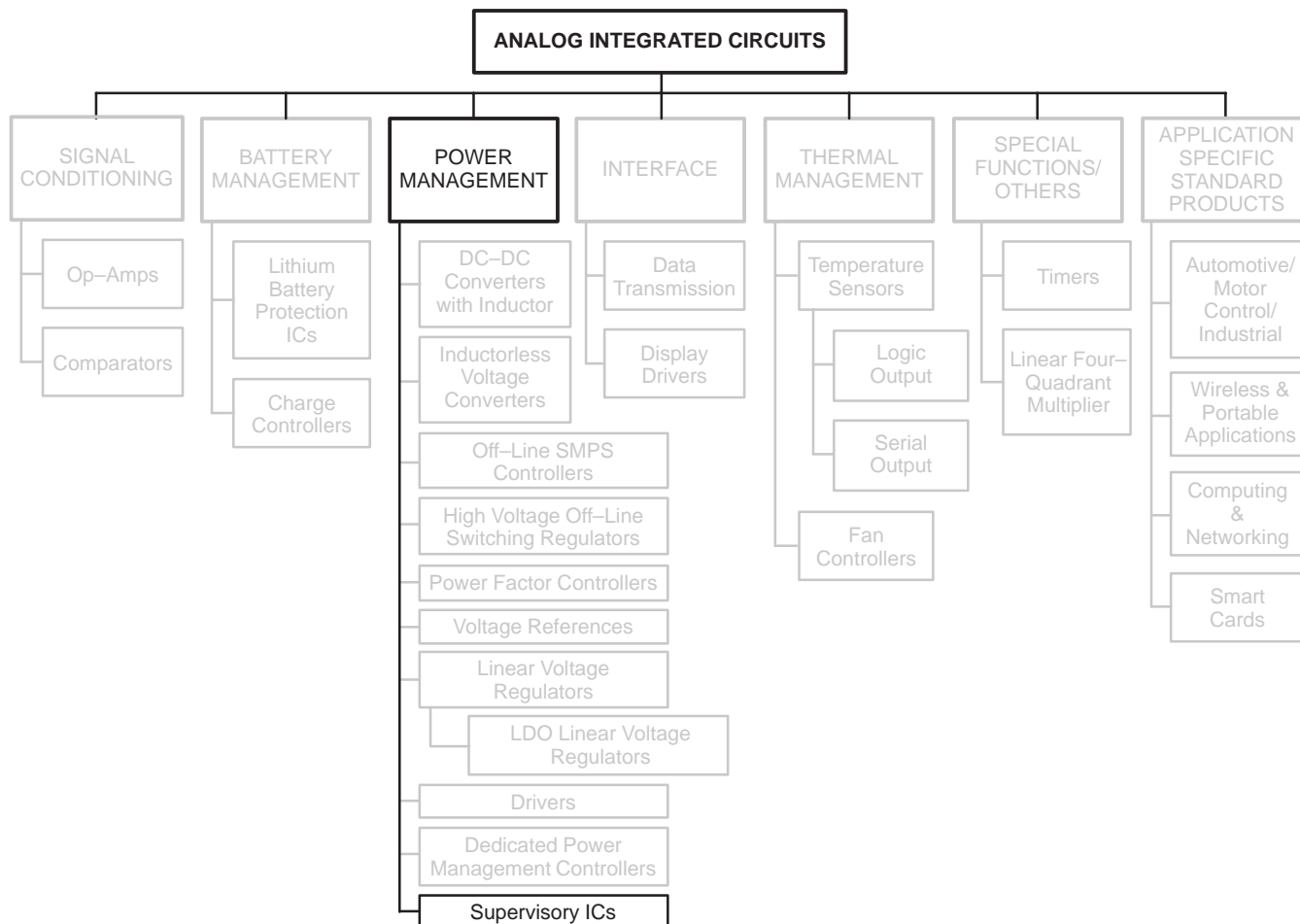

Supervisory Circuits

A variety of Power Supervisory Circuits are offered. Overvoltage sensing circuits which drive “Crowbar” SCRs are provided in several configurations from a low cost three-terminal version to 8-pin devices which

provide pin-programmable trip voltages or additional features, such as an indicator output drive and remote activation capability. An over/undervoltage protection circuit is also offered.

Overvoltage Crowbar Sensing Circuit

MC3423P1, D

T_A = 0° to +70°C, DIP-8, SO-8 Packages

This device can protect sensitive circuitry from power supply transients or regulator failure when used with an external “Crowbar” SCR. The device senses voltage and compares it to an internal 2.6 V reference. Overvoltage trip is adjustable by means of an external resistive voltage di-

vider. A minimum duration before trip is programmable with an external capacitor. Other features include a 300 mA high current output for driving the gate of a “Crowbar” SCR, an open-collector indicator output and remote activation capability.

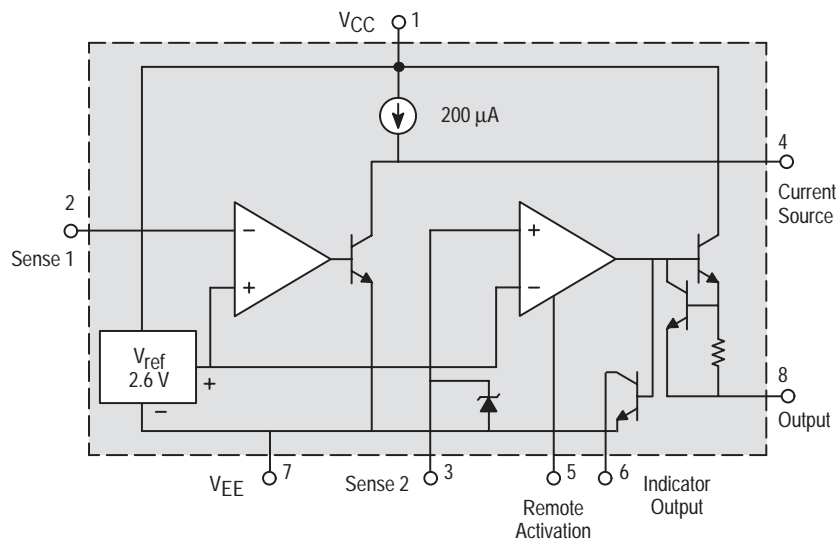

Over/Undervoltage Protection Circuit

MC3425P1

$T_A = 0^\circ$ to $+70^\circ\text{C}$, DIP-8 Package

The MC3425 is a power supply supervisory circuit containing all the necessary functions required to monitor over and undervoltage fault conditions. This device features dedicated over and undervoltage sensing channels with independently programmable time delays. The overvoltage channel has a high current drive output

for use in conjunction with an external SCR "Crowbar" for shutdown. The undervoltage channel input comparator has hysteresis which is externally programmable, and an open-collector output for fault indication.

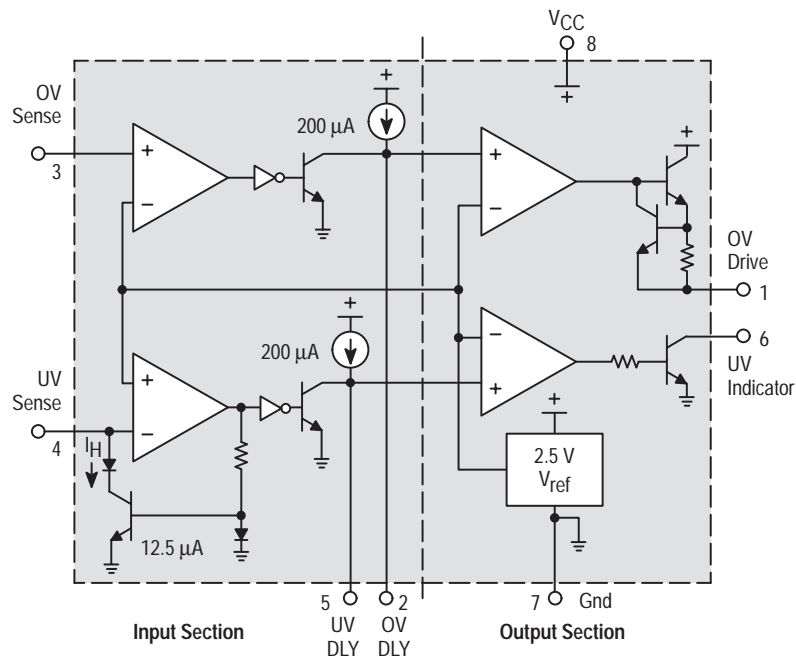

SMPSRM

Supervisory Circuits (continued)

Micropower Undervoltage Sensing Circuits

MC33464H, N

T_A = -30° to +80°C, SOT-89, SOT-23 5 Leads Packages

The MC33464 series are micropower undervoltage sensing circuits that are specifically designed for use with battery powered microprocessor based systems, where extended battery life is required. A choice of several threshold voltages from 0.9 V to 4.5 V are available. These devices feature a very low quiescent bias current of 0.8 µA typical.

The MC33464 series features a highly accurate voltage reference, a comparator with precise thresholds and built-in hysteresis to prevent erratic reset operation, a choice of output configurations between open drain or complementary MOS, and guaranteed operation below 1.0 V with extremely low standby current. These devices are available in either SOT-89 3-pin or SOT-23 5-pin

surface mount packages.

Applications include direct monitoring of the MPU/logic power supply used in portable, appliance, automotive and industrial equipment.

MC33464 Features:

- Extremely Low Standby Current of 0.8 µA at V_{in} = 1.5 V
- Wide Input Voltage Range (0.7 V to 10 V)
- Monitors Power Supply Voltages from 1.1 V to 5.0 V
- High Accuracy Detector Threshold (±2.5%)
- Two Reset Output Types (Open Drain or Complementary Drive)
- Two Surface Mount Packages (SOT-89 or SOT-23 5-Pin)

ORDERING INFORMATION

Device	Threshold Voltage	Type	Operating Temperature Range	Package (Qty/Reel)		
MC33464H-09AT1	0.9	Open Drain Reset	T _A = -30° to +80°C	SOT-89 (1000)		
MC33464H-20AT1	2.0					
MC33464H-27AT1	2.7					
MC33464H-30AT1	3.0					
MC33464H-45AT1	4.5					
MC33464H-09CT1	0.9	Compl. MOS Reset			T _A = -30° to +80°C	SOT-23 (3000) 5 Leads
MC33464H-20CT1	2.0					
MC33464H-27CT1	2.7					
MC33464H-30CT1	3.0					
MC33464H-45CT1	4.5					
MC33464N-09ATR	0.9	Open Drain Reset	T _A = -30° to +80°C	SOT-23 (3000) 5 Leads		
MC33464N-20ATR	2.0					
MC33464N-21ATR	2.1					
MC33464N-27ATR	2.7					
MC33464N-30ATR	3.0					
MC33464N-45ATR	4.5					
MC33464N-09CTR	0.9	Compl. MOS Reset			T _A = -30° to +80°C	SOT-23 (3000) 5 Leads
MC33464N-20CTR	2.0					
MC33464N-27CTR	2.7					
MC33464N-30CTR	3.0					
MC33464N-45CTR	4.5					

Other voltages from 0.9 to 6.0 V, in 0.1 V increments, are available. Consult factory for information.

MC33464X-YYATZ Open Drain Configuration

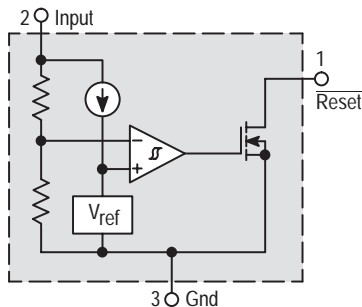

MC33464X-YYCTZ Complementary Drive Configuration

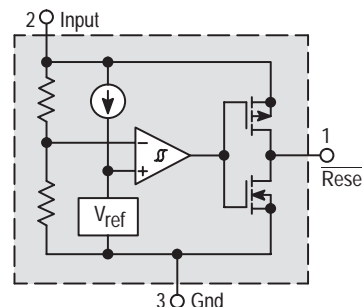

X Denotes Package Type
YY Denotes Threshold Voltage
TZ Denotes Taping Type

Supervisory Circuits (continued)

Micropower Undervoltage Sensing Circuits with Programmable Output Delay

MC33465N

$T_A = -30^\circ$ to $+80^\circ\text{C}$, SOT-23 5 Leads

The MC33465 series are micropower undervoltage sensing circuits that are specifically designed for use with battery powered microprocessor based systems, where extended battery life is required. A choice of several threshold voltages from 0.9 V to 4.5 V are available. This device features a very low quiescent bias current of 1.0 μA typical.

The MC33465 series features a highly accurate voltage reference, a comparator with precise thresholds and built-in hysteresis to prevent erratic reset operation, a choice of output configurations between open drain or complementary, a time delayed output, which can be programmed by the system designer, and guaranteed operation below 1.0 V with extremely low standby current. This device is available in a SOT-23 5-pin surface mount package.

Applications include direct monitoring of the MPU/logic power supply used in appliance, automotive, industrial and portable equipment.

MC33465 Features:

- Extremely Low Standby Current of 1.0 μA at $V_{in} = 3.5\text{ V}$
- Wide Input Voltage Range (0.7 V to 10 V)
- Monitors Power Supply Voltages from 1.1 V to 5.0 V
- High Accuracy Detector Threshold ($\pm 2.5\%$)
- Two $\overline{\text{Reset}}$ Output Types (Open Drain or Complementary Drive)
- Programmable Output Delay by External Capacitor (100 ms typ. with 0.15 μF)
- Surface Mount Package (SOT-23 5-Pin)
- Convenient Tape and Reel (3000 per Reel)

ORDERING INFORMATION

Device	Threshold Voltage	Type	Operating Temperature Range	Package		
MC33465N-09ATR	0.9	Open Drain $\overline{\text{Reset}}$	$T_A = -30^\circ$ to $+80^\circ\text{C}$	SOT-23 5 Leads		
MC33465N-20ATR	2.0					
MC33465N-27ATR	2.7					
MC33465N-30ATR	3.0					
MC33465N-32ATR	3.2					
MC33465N-45ATR	4.5					
MC33465N-09CTR	0.9	Compl. MOS $\overline{\text{Reset}}$			$T_A = -30^\circ$ to $+80^\circ\text{C}$	SOT-23 5 Leads
MC33465N-20CTR	2.0					
MC33465N-27CTR	2.7					
MC33465N-30CTR	3.0					
MC33465N-43CTR	4.3					
MC33465N-45CTR	4.5					

Other voltages from 0.9 to 6.0 V, in 0.1 V increments, are available. Consult factory for information.

MC33465N-YYATR
Open Drain Output Configuration

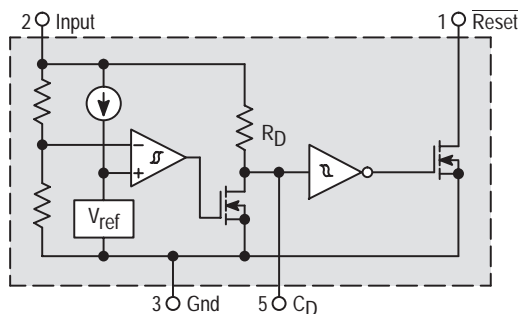

MC33465N-YYCTR
Complementary Output Configuration

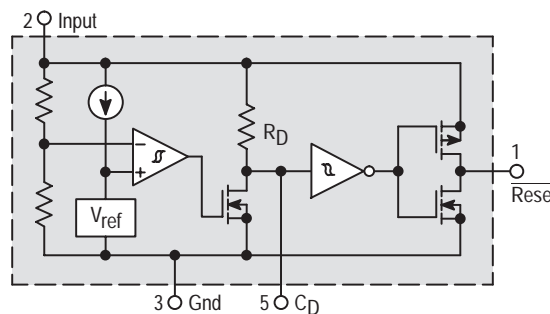

YY Denotes Threshold Voltage

SMPSRM

Supervisory Circuits (continued)

Undervoltage Sensing Circuit

MC34064P-5, D-5, DM-5

$T_A = 0^\circ$ to $+70^\circ\text{C}$, TO-92, SO-8

MC33064P-5, D-5, DM-5

$T_A = -40^\circ$ to $+85^\circ\text{C}$, TO-92, SO-8

MC34164P-3, P-5, D-3, D-5, DM-3, DM-5

$T_A = 0^\circ$ to $+70^\circ\text{C}$, TO-92, SO-8

MC33164P-3, P-5, D-3, D-5, DM-3, DM-5

$T_A = -40^\circ$ to $+85^\circ\text{C}$, TO-92, SO-8

The MC34064 and MC34164 are two families of undervoltage sensing circuits specifically designed for use as reset controllers in microprocessor-based systems. They offer the designer an economical solution for low voltage detection with a single external resistor. Both parts feature a trimmed bandgap reference, and a comparator with precise thresholds and built-in hysteresis to prevent erratic reset operation.

The two families of undervoltage sensing circuits taken together, cover the needs of the most commonly specified power supplies used in MCU/MPU systems. Key parameter specifications of the MC34164 family were chosen to complement the MC34064 series. The table summarizes critical parameters of both families. The MC34064 fulfills the needs of a $5.0\text{ V} \pm 5\%$ system and features a tighter hysteresis specification. The MC34164

series covers $5.0\text{ V} \pm 10\%$ and $3.0\text{ V} \pm 5\%$ power supplies with significantly lower power consumption, making them ideal for applications where extended battery life is required such as consumer products or hand held equipment.

Applications include direct monitoring of the 5.0 V MPU/logic power supply used in appliance, automotive, consumer, and industrial equipment.

The MC34164 is specifically designed for battery powered applications where low bias current ($1/25\text{th}$ of the MC34064's) is an important characteristic.

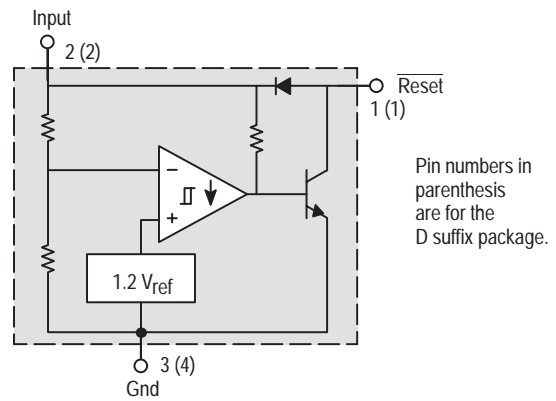

Table 1. Undervoltage Sense/Reset Controller Features

MC34X64 devices are specified to operate from 0° to $+70^\circ\text{C}$, and MC33X64 devices operate from -40° to $+85^\circ\text{C}$.

Device	Standard Power Supply Supported	Typical Threshold Voltage (V)	Typical Hysteresis Voltage (V)	Minimum Output Sink Current (mA)	Power Supply Input Voltage Range (V)	Maximum Quiescent Input Current	Package
MC34064/MC33064	$5.0\text{ V} \pm 5\%$	4.6	0.02	10	1.0 to 10	500 μA @ $V_{in} = 5.0\text{ V}$	TO-92
							SO-8
MC34164/MC33164	$5.0\text{ V} \pm 10\%$	4.3	0.09	7.0	1.0 to 12	20 μA @ $V_{in} = 5.0\text{ V}$	TO-92
							SO-8
MC34164/MC33164	$3.0\text{ V} \pm 5\%$	2.7	0.06	6.0	1.0 to 12	15 μA @ $V_{in} = 3.0\text{ V}$	TO-92
							SO-8

Supervisory Circuits (continued) Universal Voltage Monitor

MC34161P, D

$T_A = 0^\circ$ to $+70^\circ\text{C}$, DIP-8, SO-8

MC33161P, D

$T_A = -40^\circ$ to $+85^\circ\text{C}$, Case 626, 751

The MC34161, MC33161 series are universal voltage monitors intended for use in a wide variety of voltage sensing applications. These devices offer the circuit designer an economical solution for positive and negative voltage detection. The circuit consists of two comparator channels each with hysteresis, a unique Mode Select Input for channel programming, a pinned out 2.54 V reference, and two open collector outputs capable of sinking in excess of 10 mA. Each comparator channel can be configured as either inverting or noninverting by the Mode Select Input. This allows over, under, and window detection of positive and negative voltages. The minimum supply voltage needed for these devices to be fully functional is 2.0 V for positive voltage sensing and 4.0 V for negative voltage sensing.

Applications include direct monitoring of positive and negative voltages used in appliance, automotive, consumer, and industrial equipment.

- Unique Mode Select Input Allows Channel Programming
- Over, Under, and Window Voltage Detection
- Positive and Negative Voltage Detection
- Fully Functional at 2.0 V for Positive Voltage Sensing and 4.0 V for Negative Voltage Sensing

- Pinned Out 2.54 V Reference with Current Limit Protection
- Low Standby Current
- Open Collector Outputs for Enhanced Device Flexibility

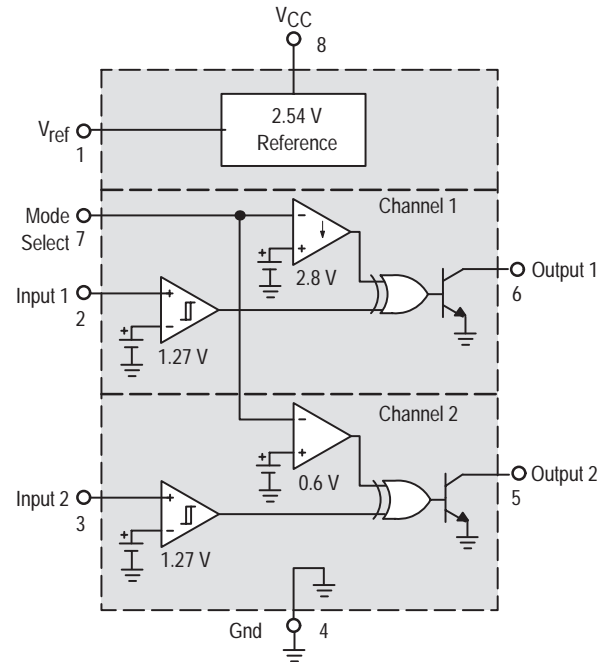

TRUTH TABLE

Mode Select Pin 7	Input 1 Pin 2	Output 1 Pin 6	Input 2 Pin 3	Output 2 Pin 5	Comments
GND	0	0	0	0	Channels 1 & 2: Noninverting
	1	1	1	1	
V_{ref}	0	0	0	1	Channel 1: Noninverting Channel 2: Inverting
	1	1	1	0	
$V_{CC} (>2.0\text{ V})$	0	1	0	1	Channels 1 & 2: Inverting
	1	0	1	0	

POSITIVE AND NEGATIVE OVERVOLTAGE DETECTOR

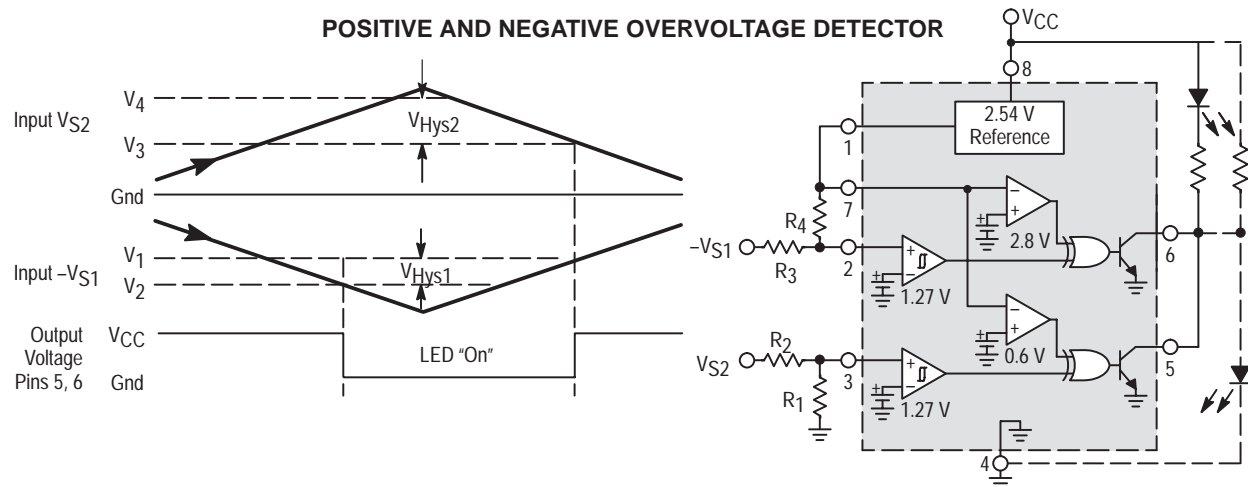

SMPSRM

Supervisory Circuits (continued)

3-Pin Microprocessor Reset Monitors

MAX809/810

$T_A = -40^\circ$ to $+85^\circ\text{C}$, SOT-23

The MAX809 and MAX810 are cost-effective system supervisor circuits designed to monitor V_{CC} in digital systems and provide a reset signal to the host processor when necessary. No external components are required.

The reset output is driven active within 20 μsec of V_{CC} falling through the reset voltage threshold. Reset is maintained active for a minimum of 140msec after V_{CC} rises above the reset threshold. The MAX810 has an active-high $\overline{\text{RESET}}$ output while the MAX809 has an active-low $\overline{\text{RESET}}$ output. The output of the MAX809 is guaranteed valid down to $V_{CC} = 1\text{V}$. Both devices are available in a SOT-23 package.

The MAX809/810 are optimized to reject fast transient glitches on the V_{CC} line. Low supply current of 17 μA ($V_{CC} = 3.3\text{V}$) makes these devices suitable for battery powered applications.

MAX809/810 Features:

- Precision V_{CC} Monitor for 3.0V, 3.3V, and 5.0V Supplies
- 140msec Guaranteed Minimum $\overline{\text{RESET}}$, RESET Output Duration
- $\overline{\text{RESET}}$ Output Guaranteed to $V_{CC} = 1.0\text{V}$ (MAX809)
- Low 17 μA Supply Current
- V_{CC} Transient Immunity
- Small SOT-23 Package
- No External Components
- Wide Operating Temperature: -40°C to 85°C

Applications:

- Computers
- Embedded Systems
- Battery Powered Equipment
- Critical μP Power Supply Monitoring

ORDERING INFORMATION

Device	Operating Temperature Range	Package
MAX809	$T_A = -40^\circ$ to $+85^\circ\text{C}$	SOT-23
MAX810		

Typical Application Diagram

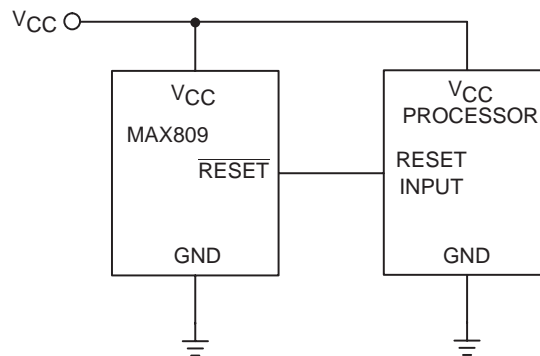

Supervisory Circuits (continued) Under Voltage Detector Series

MC33460/MC33461

$T_A = -40^\circ$ to $+85^\circ\text{C}$, SC-82AB

The MC33460 and MC33461 series are ultra-low power CMOS under-voltage detectors with very tight threshold accuracy specifically designed for accurate monitoring of power supplies. The devices are optimized for use in battery powered systems where low quiescent current and small packaging are required. The device generates an active-low signal whenever the input voltage falls below the factory set $\pm 2\%$ threshold. Hysteresis is provided to ensure reliable output switching.

The MC33460/1 series features a highly accurate voltage reference, a comparator with a precision voltage threshold, and built-in hysteresis to prevent erratic operation and a choice of output configurations between Open Drain (MC33460) and complementary push-pull (MC33461). The products are offered in 9 standard voltage thresholds ranging from 0.9V to 4.5V. Other threshold voltages from 1.0 to 5.0V are available in

100mV steps. The devices can operate to a very low input voltage level and are housed in the ultra-miniature SC-82AB package.

MC33460/1 Features:

- Available in Open Drain or Push-Pull Output
- Output State Guaranteed to $V_{in} = 0.8\text{ V}$
- Tight Detector Voltage Accuracy ($\pm 2.0\%$)
- Extended Temperature Operation (-40°C to 85°C)
- Ultra Low Quiescent Current ($0.8\ \mu\text{A}$ at $V_{in} = 1.5\text{ V}$ typical)
- Wide Range of Operating Voltage (0.7 V to 10 V)

Applications:

- Low Battery Detector
- Power-Fail Indicator
- Microprocessor Reset Generator
- Window Comparator
- Battery Backup Circuit

ORDERING INFORMATION

Device	Operating Temperature Range	Package
MC33460	$T_A = -40^\circ$ to $+85^\circ\text{C}$	SC-82AB
MC33461		

Representative Block Diagrams

MC33460
Nch Open Drain Configuration

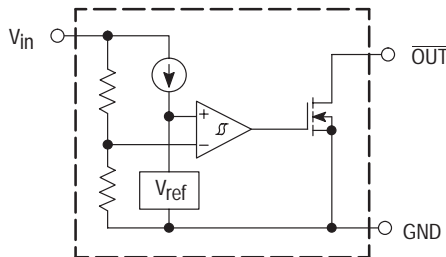

MC33461
CMOS Configuration

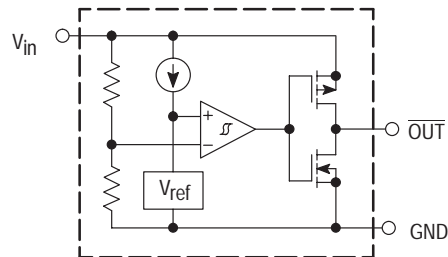

System Management

In Brief . . .

Power supplies, MCU-based systems, industrial controls, computer systems and many other products, portable or not, are requiring system management functions which monitor voltages to ensure proper system operation.

These circuits monitor critical circuit conditions and report any violations of prescribed limits to a microprocessor. The microprocessor will then take appropriate action such as storing data before executing a graceful shutdown.

ON Semiconductor offers a wide variety of voltage supervisory circuits (Undervoltage or Overvoltage) designed for use where precise voltage limits or windows are required for reliable system operation.

Newer supervisory circuits have utilized CMOS technology and miniature surface mount packages (SOT23-5 leads) to reduce the current consumption and the PCB board area. This makes them particularly suited for battery-powered applications.

	Page
Supervisory Circuits	135
Overvoltage Crowbar Sensing Circuit	135
Over/Undervoltage Protection Circuit	136
Micropower Undervoltage Sensing Circuits	137
Micropower Undervoltage Sensing Circuits with Programmable Output Delay	138
Undervoltage Sensing Circuit	139
Universal Voltage Monitor	140
3-Pin Microprocessor Reset Monitors	141

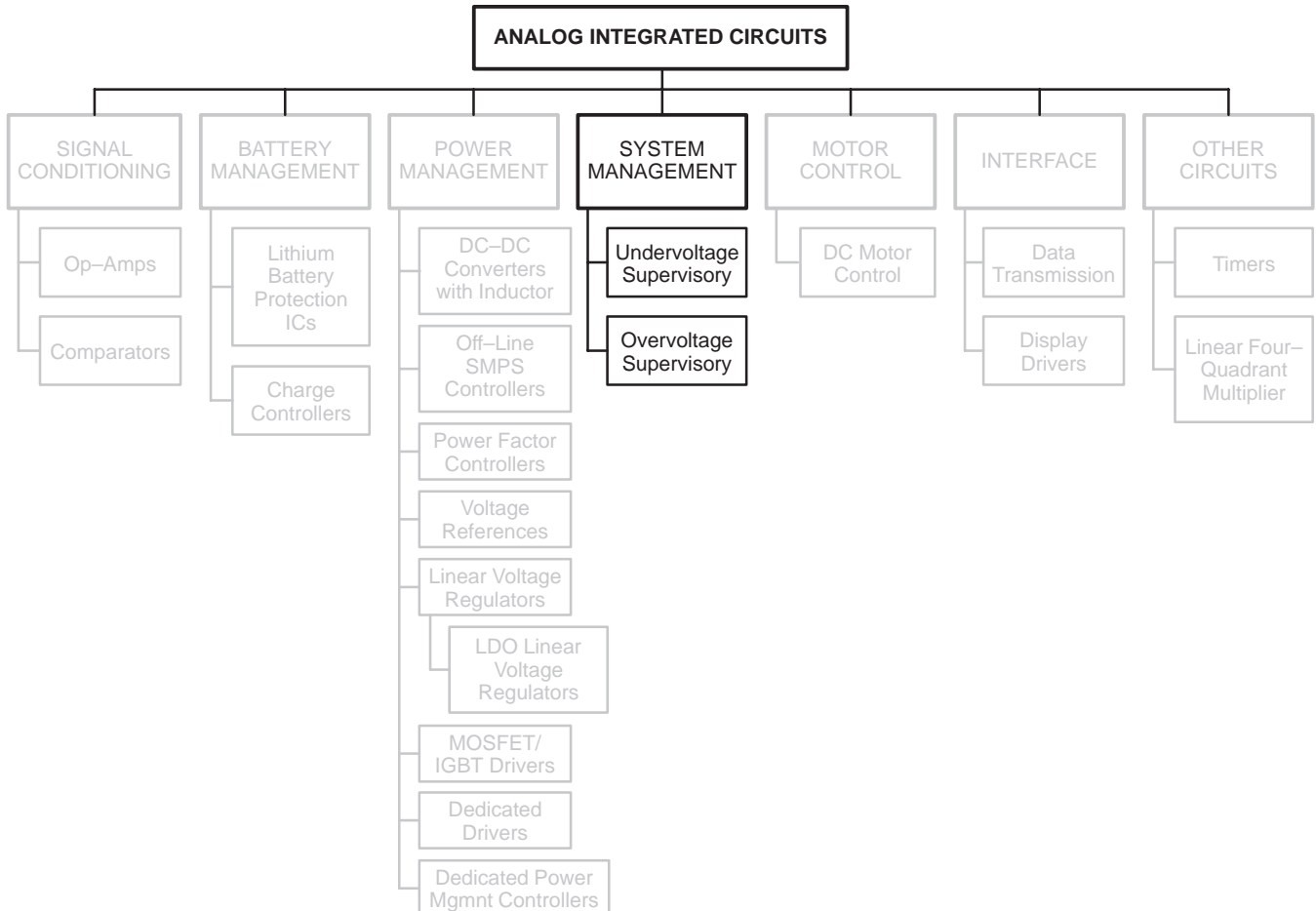

Supervisory Circuits

A variety of Power Supervisory Circuits are offered. Overvoltage sensing circuits which drive “Crowbar” SCRs are provided in several configurations from a low cost three-terminal version to 8-pin devices which

provide pin-programmable trip voltages or additional features, such as an indicator output drive and remote activation capability. An over/undervoltage protection circuit is also offered.

Overvoltage Crowbar Sensing Circuit

MC3423P1, D

$T_A = 0^\circ$ to $+70^\circ\text{C}$, DIP-8, SO-8 Packages

This device can protect sensitive circuitry from power supply transients or regulator failure when used with an external “Crowbar” SCR. The device senses voltage and compares it to an internal 2.6 V reference. Overvoltage trip is adjustable by means of an external

resistive voltage divider. A minimum duration before trip is programmable with an external capacitor. Other features include a 300 mA high current output for driving the gate of a “Crowbar” SCR, an open-collector indicator output and remote activation capability.

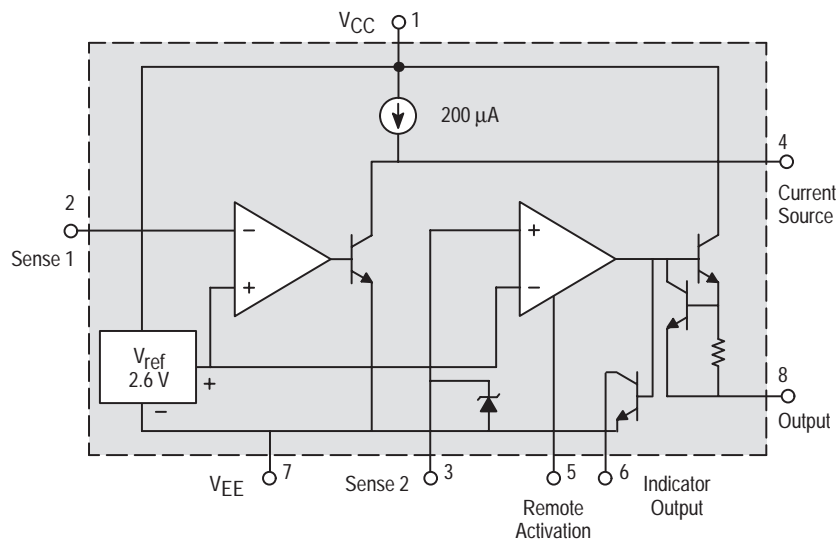

SMPSRM

Over/Undervoltage Protection Circuit

MC3425P1

T_A = 0° to +70°C, DIP-8 Package

The MC3425 is a power supply supervisory circuit containing all the necessary functions required to monitor over and undervoltage fault conditions. This device features dedicated over and undervoltage sensing channels with independently programmable time delays. The overvoltage channel has a high current

drive output for use in conjunction with an external SCR "Crowbar" for shutdown. The undervoltage channel input comparator has hysteresis which is externally programmable, and an open-collector output for fault indication.

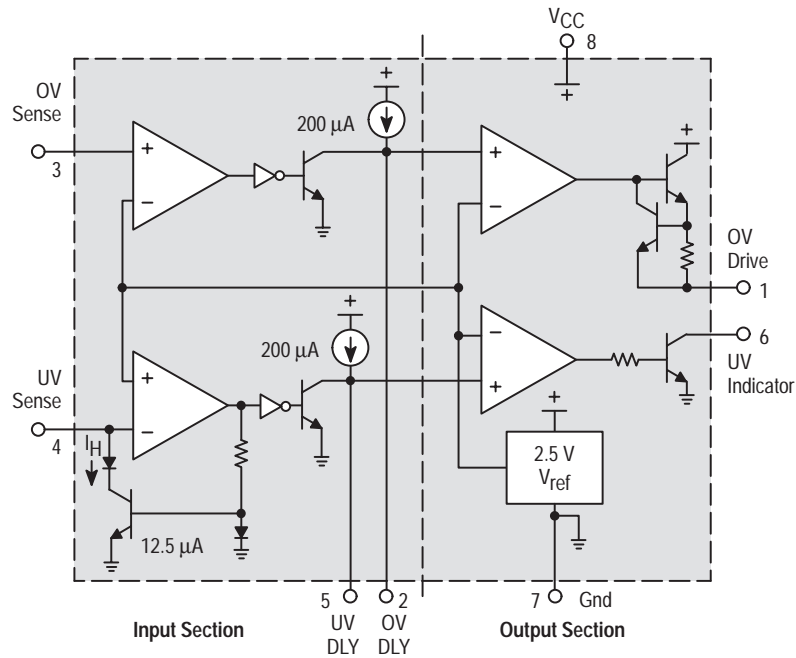

Supervisory Circuits (continued)

Micropower Undervoltage Sensing Circuits

MC33464H, N

T_A = -30° to +80°C, SOT-89, SOT-23 5 Leads Packages

The MC33464 series are micropower undervoltage sensing circuits that are specifically designed for use with battery powered microprocessor based systems, where extended battery life is required. A choice of several threshold voltages from 0.9 V to 4.5 V are available. These devices feature a very low quiescent bias current of 0.8 μA typical.

The MC33464 series features a highly accurate voltage reference, a comparator with precise thresholds and built-in hysteresis to prevent erratic reset operation, a choice of output configurations between open drain or complementary MOS, and guaranteed operation below 1.0 V with extremely low standby current. These devices are available in either SOT-89 3-pin or

SOT-23 5-pin surface mount packages.

Applications include direct monitoring of the MPU/logic power supply used in portable, appliance, automotive and industrial equipment.

MC33464 Features:

- Extremely Low Standby Current of 0.8 μA at V_{in} = 1.5 V
- Wide Input Voltage Range (0.7 V to 10 V)
- Monitors Power Supply Voltages from 1.1 V to 5.0 V
- High Accuracy Detector Threshold (±2.5%)
- Two Reset Output Types (Open Drain or Complementary Drive)
- Two Surface Mount Packages (SOT-89 or SOT-23 5-Pin)

ORDERING INFORMATION

Device	Threshold Voltage	Type	Operating Temperature Range	Package (Qty/Reel)	
MC33464H-09AT1 MC33464H-20AT1 MC33464H-27AT1 MC33464H-30AT1 MC33464H-45AT1	0.9 2.0 2.7 3.0 4.5	Open Drain Reset	T _A = -30° to +80°C	SOT-89 (1000)	
MC33464H-09CT1 MC33464H-20CT1 MC33464H-27CT1 MC33464H-30CT1 MC33464H-45CT1	0.9 2.0 2.7 3.0 4.5	Compl. MOS Reset			
MC33464N-09ATR MC33464N-20ATR MC33464N-21ATR MC33464N-27ATR MC33464N-30ATR MC33464N-45ATR	0.9 2.0 2.1 2.7 3.0 4.5	Open Drain Reset			SOT-23 (3000) 5 Leads
MC33464N-09CTR MC33464N-20CTR MC33464N-27CTR MC33464N-30CTR MC33464N-45CTR	0.9 2.0 2.7 3.0 4.5	Compl. MOS Reset			

Other voltages from 0.9 to 6.0 V, in 0.1 V increments, are available. Consult factory for information.

MC33464X-YYATZ Open Drain Configuration

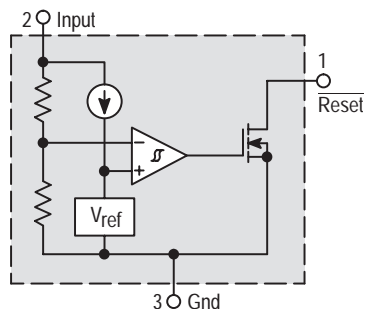

MC33464X-YYCTZ Complementary Drive Configuration

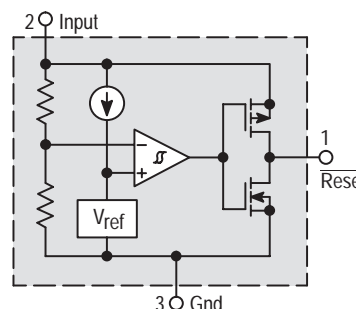

X Denotes Package Type
YY Denotes Threshold Voltage
TZ Denotes Taping Type

SMPSRM

Supervisory Circuits (continued)

Micropower Undervoltage Sensing Circuits with Programmable Output Delay

MC33465N

$T_A = -30^\circ$ to $+80^\circ\text{C}$, SOT-23 5 Leads

The MC33465 series are micropower undervoltage sensing circuits that are specifically designed for use with battery powered microprocessor based systems, where extended battery life is required. A choice of several threshold voltages from 0.9 V to 4.5 V are available. This device features a very low quiescent bias current of 1.0 μA typical.

The MC33465 series features a highly accurate voltage reference, a comparator with precise thresholds and built-in hysteresis to prevent erratic reset operation, a choice of output configurations between open drain or complementary, a time delayed output, which can be programmed by the system designer, and guaranteed operation below 1.0 V with extremely low standby current. This device is available in a SOT-23 5-pin surface mount package.

Applications include direct monitoring of the MPU/logic power supply used in appliance, automotive, industrial and portable equipment.

MC33465 Features:

- Extremely Low Standby Current of 1.0 μA at $V_{in} = 3.5\text{ V}$
- Wide Input Voltage Range (0.7 V to 10 V)
- Monitors Power Supply Voltages from 1.1 V to 5.0 V
- High Accuracy Detector Threshold ($\pm 2.5\%$)
- Two $\overline{\text{Reset}}$ Output Types (Open Drain or Complementary Drive)
- Programmable Output Delay by External Capacitor (100 ms typ. with 0.15 μF)
- Surface Mount Package (SOT-23 5-Pin)
- Convenient Tape and Reel (3000 per Reel)

ORDERING INFORMATION

Device	Threshold Voltage	Type	Operating Temperature Range	Package
MC33465N-09ATR	0.9	Open Drain $\overline{\text{Reset}}$	$T_A = -30^\circ$ to $+80^\circ\text{C}$	SOT-23 5 Leads
MC33465N-20ATR	2.0			
MC33465N-27ATR	2.7			
MC33465N-30ATR	3.0			
MC33465N-32ATR	3.2			
MC33465N-45ATR	4.5			
MC33465N-09CTR	0.9	Compl. MOS $\overline{\text{Reset}}$		
MC33465N-20CTR	2.0			
MC33465N-27CTR	2.7			
MC33465N-30CTR	3.0			
MC33465N-43CTR	4.3			
MC33465N-45CTR	4.5			

Other voltages from 0.9 to 6.0 V, in 0.1 V increments, are available. Consult factory for information.

MC33465N-YYATR
Open Drain Output Configuration

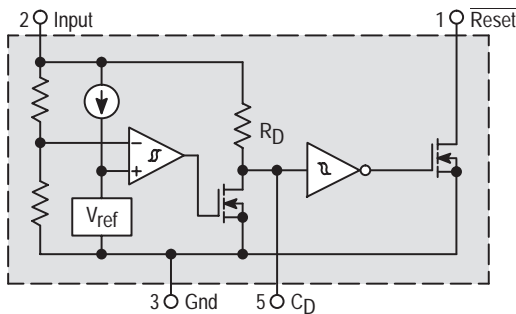

MC33465N-YYCTR
Complementary Output Configuration

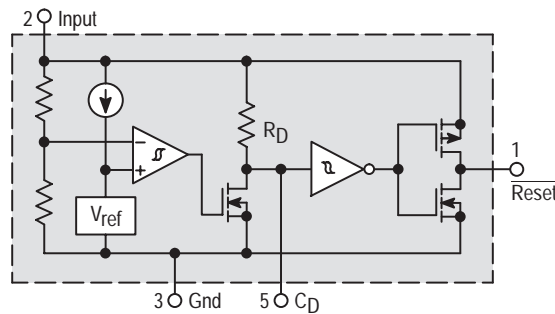

YY Denotes Threshold Voltage

Supervisory Circuits (continued)

Undervoltage Sensing Circuit

MC34064P-5, D-5, DM-5

T_A = 0° to +70°C, TO-92, SO-8

MC33064P-5, D-5, DM-5

T_A = -40° to +85°C, TO-92, SO-8

MC34164P-3, P-5, D-3, D-5, DM-3, DM-5

T_A = 0° to +70°C, TO-92, SO-8

MC33164P-3, P-5, D-3, D-5, DM-3, DM-5

T_A = -40° to +85°C, TO-92, SO-8

The MC34064 and MC34164 are two families of undervoltage sensing circuits specifically designed for use as reset controllers in microprocessor-based systems. They offer the designer an economical solution for low voltage detection with a single external resistor. Both parts feature a trimmed bandgap reference, and a comparator with precise thresholds and built-in hysteresis to prevent erratic reset operation.

The two families of undervoltage sensing circuits taken together, cover the needs of the most commonly specified power supplies used in MCU/MPU systems. Key parameter specifications of the MC34164 family were chosen to complement the MC34064 series. The table summarizes critical parameters of both families. The MC34064 fulfills the needs of a 5.0 V ± 5% system and features a tighter hysteresis specification. The

MC34164 series covers 5.0 V ± 10% and 3.0 V ± 5% power supplies with significantly lower power consumption, making them ideal for applications where extended battery life is required such as consumer products or hand held equipment.

Applications include direct monitoring of the 5.0 V MPU/ logic power supply used in appliance, automotive, consumer, and industrial equipment.

The MC34164 is specifically designed for battery powered applications where low bias current (1/25th of the MC34064's) is an important characteristic.

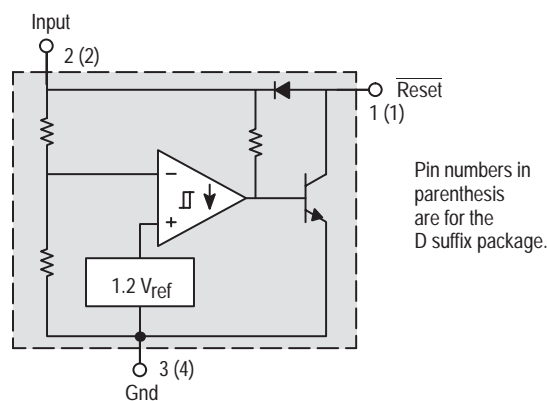

Table 1. Undervoltage Sense/Reset Controller Features

MC34X64 devices are specified to operate from 0° to +70°C, and MC33X64 devices operate from -40° to +85°C.

Device	Standard Power Supply Supported	Typical Threshold Voltage (V)	Typical Hysteresis Voltage (V)	Minimum Output Sink Current (mA)	Power Supply Input Voltage Range (V)	Maximum Quiescent Input Current	Package
MC34064/MC33064	5.0 V ± 5%	4.6	0.02	10	1.0 to 10	500 μA @ V _{in} = 5.0 V	TO-92
							SO-8
MC34164/MC33164	5.0 V ± 10%	4.3	0.09	7.0	1.0 to 12	20 μA @ V _{in} = 5.0 V	TO-92
							SO-8
MC34164/MC33164	3.0 V ± 5%	2.7	0.06	6.0	1.0 to 12	15 μA @ V _{in} = 3.0 V	TO-92
							SO-8

Supervisory Circuits (continued) Universal Voltage Monitor

MC34161P, D

$T_A = 0^\circ$ to $+70^\circ\text{C}$, DIP-8, SO-8

MC33161P, D

$T_A = -40^\circ$ to $+85^\circ\text{C}$, Case 626, 751

The MC34161, MC33161 series are universal voltage monitors intended for use in a wide variety of voltage sensing applications. These devices offer the circuit designer an economical solution for positive and negative voltage detection. The circuit consists of two comparator channels each with hysteresis, a unique Mode Select Input for channel programming, a pinned out 2.54 V reference, and two open collector outputs capable of sinking in excess of 10 mA. Each comparator channel can be configured as either inverting or noninverting by the Mode Select Input. This allows over, under, and window detection of positive and negative voltages. The minimum supply voltage needed for these devices to be fully functional is 2.0 V for positive voltage sensing and 4.0 V for negative voltage sensing.

Applications include direct monitoring of positive and negative voltages used in appliance, automotive, consumer, and industrial equipment.

- Unique Mode Select Input Allows Channel Programming
- Over, Under, and Window Voltage Detection
- Positive and Negative Voltage Detection
- Fully Functional at 2.0 V for Positive Voltage Sensing and 4.0 V for Negative Voltage Sensing

- Pinned Out 2.54 V Reference with Current Limit Protection
- Low Standby Current
- Open Collector Outputs for Enhanced Device Flexibility

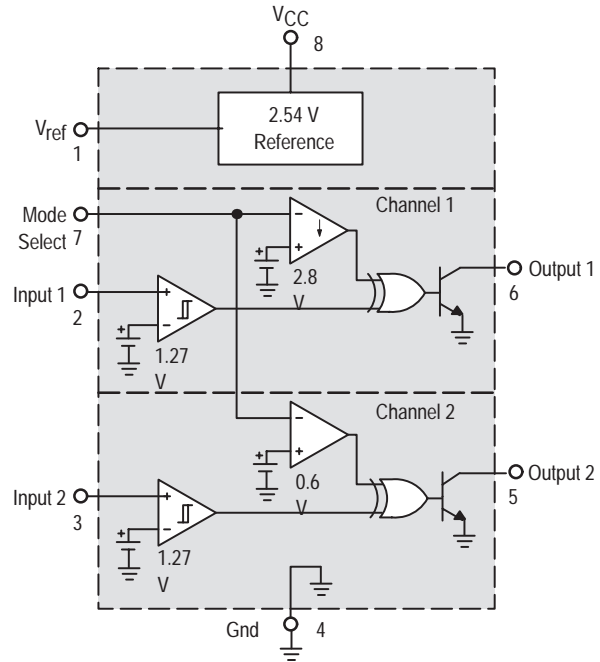

TRUTH TABLE

Mode Select Pin 7	Input 1 Pin 2	Output 1 Pin 6	Input 2 Pin 3	Output 2 Pin 5	Comments
GND	0 1	0 1	0 1	0 1	Channels 1 & 2: Noninverting
V_{ref}	0 1	0 1	0 1	1 0	Channel 1: Noninverting Channel 2: Inverting
$V_{CC} (>2.0\text{ V})$	0 1	1 0	0 1	1 0	Channels 1 & 2: Inverting

POSITIVE AND NEGATIVE OVERVOLTAGE DETECTOR

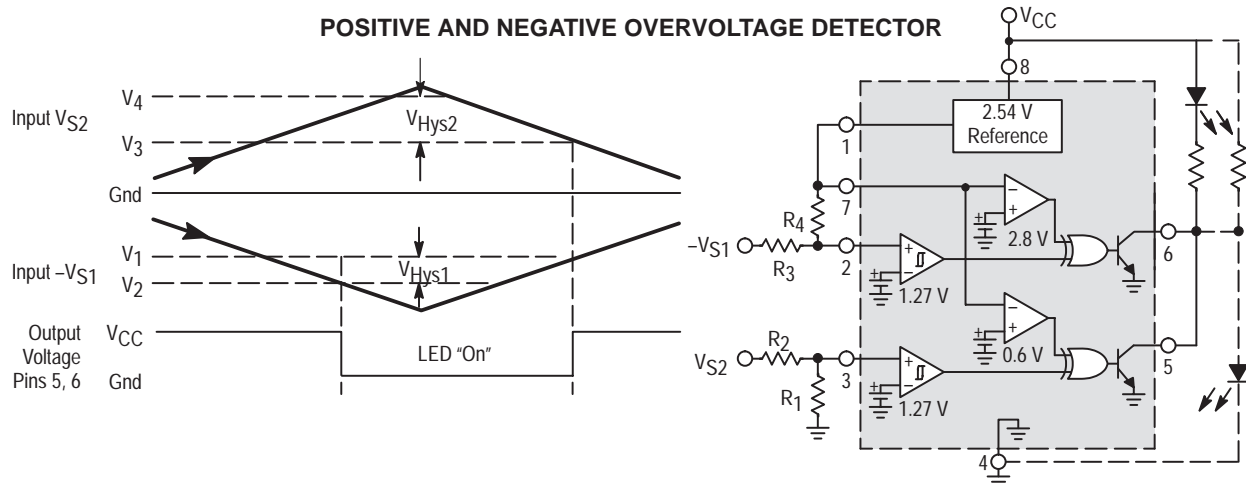

Supervisory Circuits (continued)

3-Pin Microprocessor Reset Monitors

MAX809/810

$T_A = -40^\circ$ to $+85^\circ\text{C}$, SOT-23

The MAX809 and MAX810 are cost-effective system supervisor circuits designed to monitor V_{CC} in digital systems and provide a reset signal to the host processor when necessary. No external components are required.

The reset output is driven active within 20 μsec of V_{CC} falling through the reset voltage threshold. Reset is maintained active for a minimum of 140msec after V_{CC} rises above the reset threshold. The MAX810 has an active-high $\overline{\text{RESET}}$ output while the MAX809 has an active-low $\overline{\text{RESET}}$ output. The output of the MAX809 is guaranteed valid down to $V_{CC} = 1\text{V}$. Both devices are available in a SOT-23 package.

The MAX809/810 are optimized to reject fast transient glitches on the V_{CC} line. Low supply current of $17\mu\text{A}$ ($V_{CC} = 3.3\text{V}$) makes these devices suitable for battery powered applications.

MAX809/810 Features:

- Precision V_{CC} Monitor for 3.0V, 3.3V, and 5.0V Supplies
- 140msec Guaranteed Minimum $\overline{\text{RESET}}$, RESET Output Duration
- $\overline{\text{RESET}}$ Output Guaranteed to $V_{CC} = 1.0\text{V}$ (MAX809)
- Low $17\mu\text{A}$ Supply Current
- V_{CC} Transient Immunity
- Small SOT-23 Package
- No External Components
- Wide Operating Temperature: -40°C to 85°C

Applications:

- Computers
- Embedded Systems
- Battery Powered Equipment
- Critical μP Power Supply Monitoring

ORDERING INFORMATION

Device	Operating Temperature Range	Package
MAX809	$T_A = -40^\circ$ to $+85^\circ\text{C}$	SOT-23
MAX810		

Typical Application Diagram

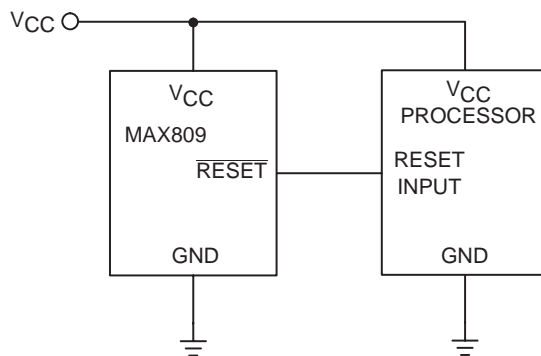

ON SEMICONDUCTOR MAJOR WORLDWIDE SALES OFFICES

UNITED STATES

ALABAMA
Huntsville (256)464-6800

CALIFORNIA
Irvine (949)753-7360
San Jose (408)749-0510

COLORADO
Littleton (303)256-5884

FLORIDA
Tampa (813)286-6181

GEORGIA
Atlanta (770)338-3810

ILLINOIS
Chicago (847)413-2500

MASSACHUSETTS
Boston (781)932-9700

MICHIGAN
Detroit (248)347-6800

MINNESOTA
Plymouth (612)249-2360

NORTH CAROLINA
Raleigh (919)870-4355

PENNSYLVANIA
Philadelphia/Horsham (215)957-4100

TEXAS
Dallas (972)516-5100

CANADA

ONTARIO
Ottawa (613)226-3491

QUEBEC
Montreal (514)333-3300

INTERNATIONAL

BRAZIL
Sao Paulo 55(011)3030-5244

CHINA
Beijing 86-10-65642288
Guangzhou 86-20-87537888
Shanghai 86-21-63747668

FRANCE
Paris 33134 635900

GERMANY
Munich 49 89 92103-0

HONG KONG
Hong Kong 852-2-610-6888

INDIA
Bangalore 91-80-5598615

ISRAEL
Tel Aviv 972-9-9522333

ITALY
Milan 39(02)82201

JAPAN
Tokyo 81-3-5487-8345

INTERNATIONAL (continued)

KOREA
Seoul 82-2-3440-7200

MALAYSIA
Penang 60(4)228-2514

MEXICO
Guadalajara 52(36)78-0750

PHILIPPINES
Manila (63)2 807-8455

PUERTO RICO
San Juan (787)641-4100

SINGAPORE
Singapore (65)4818188

SPAIN
Madrid 34(1)457-8204
or 34(1)457-8254

SWEDEN
Stockholm 46(8)734-8800

TAIWAN
Taipei 886(2)27058000

THAILAND
Bangkok 66(2)254-4910

UNITED KINGDOM
Aylesbury 44 1 (296)395252

ON SEMICONDUCTOR STANDARD DOCUMENT TYPE DEFINITIONS

DATA SHEET CLASSIFICATIONS

A Data Sheet is the fundamental publication for each individual product/device, or series of products/devices, containing detailed parametric information and any other key information needed in using, designing-in or purchasing of the product(s)/device(s) it describes. Below are the three classifications of Data Sheet: Product Preview; Advance Information; and Fully Released Technical Data

PRODUCT PREVIEW

A Product Preview is a summary document for a product/device under consideration or in the early stages of development. The Product Preview exists only until an "Advance Information" document is published that replaces it. The Product Preview is often used as the first section or chapter in a corresponding reference manual. The Product Preview displays the following disclaimer at the bottom of the first page: "ON Semiconductor reserves the right to change or discontinue this product without notice."

ADVANCE INFORMATION

The Advance Information document is for a device that is NOT fully qualified, but is in the final stages of the release process, and for which production is eminent. While the commitment has been made to produce the device, final characterization and qualification may not be complete. The Advance Information document is replaced with the "Fully Released Technical Data" document once the device/part becomes fully qualified. The Advance Information document displays the following disclaimer at the bottom of the first page: "This document contains information on a new product. Specifications and information herein are subject to change without notice."

FULLY RELEASED TECHNICAL DATA

The Fully Released Technical Data document is for a product/device that is in full production (i.e., fully released). It replaces the Advance Information document and represents a part that is fully qualified. The Fully Released Technical Data document is virtually the same document as the Product Preview and the Advance Information document with the exception that it provides information that is unavailable for a product in the early phases of development, such as complete parametric characterization data. The Fully Released Technical Data document is also a more comprehensive document than either of its earlier incarnations. This document displays no disclaimer, and while it may be informally referred to as a "data sheet," it is not labeled as such.

DATA BOOK

A Data Book is a publication that contains primarily a collection of Data Sheets, general family and/or parametric information, Application Notes and any other information needed as reference or support material for the Data Sheets. It may also contain cross reference or selector guide information, detailed quality and reliability information, packaging and case outline information, etc.

APPLICATION NOTE

An Application Note is a document that contains real-world application information about how a specific ON Semiconductor device/product is used, or information that is pertinent to its use. It is designed to address a particular technical issue. Parts and/or software must already exist and be available.

SELECTOR GUIDE

A Selector Guide is a document published, generally at set intervals, that contains key line-item, device-specific information for particular products or families. The Selector Guide is designed to be a quick reference tool that will assist a customer in determining the availability of a particular device, along with its key parameters and available packaging options. In essence, it allows a customer to quickly "select" a device. For detailed design and parametric information, the customer would then refer to the device's Data Sheet. The *Master Components Selector Guide* (SG388/D) is a listing of **ALL** currently available ON Semiconductor devices.

REFERENCE MANUAL

A Reference Manual is a publication that contains a comprehensive system or device-specific descriptions of the structure and function (operation) of a particular part/system; used overwhelmingly to describe the functionality or application of a device, series of devices or device category. Procedural information in a Reference Manual is limited to less than 40 percent (usually much less).

HANDBOOK

A Handbook is a publication that contains a collection of information on almost any given subject which does not fall into the Reference Manual definition. The subject matter can consist of information ranging from a device specific design information, to system design, to quality and reliability information.

ADDENDUM

A documentation Addendum is a supplemental publication that contains missing information or replaces preliminary information in the primary publication it supports. Individual addendum items are published cumulatively. The Addendum is destroyed upon the next revision of the primary document.

ON Semiconductor and  are trademarks of Semiconductor Components Industries, LLC (SCILLC). SCILLC reserves the right to make changes without further notice to any products herein. SCILLC makes no warranty, representation or guarantee regarding the suitability of its products for any particular purpose, nor does SCILLC assume any liability arising out of the application or use of any product or circuit, and specifically disclaims any and all liability, including without limitation special, consequential or incidental damages. "Typical" parameters which may be provided in SCILLC data sheets and/or specifications can and do vary in different applications and actual performance may vary over time. All operating parameters, including "Typicals" must be validated for each customer application by customer's technical experts. SCILLC does not convey any license under its patent rights nor the rights of others. SCILLC products are not designed, intended, or authorized for use as components in systems intended for surgical implant into the body, or other applications intended to support or sustain life, or for any other application in which the failure of the SCILLC product could create a situation where personal injury or death may occur. Should Buyer purchase or use SCILLC products for any such unintended or unauthorized application, Buyer shall indemnify and hold SCILLC and its officers, employees, subsidiaries, affiliates, and distributors harmless against all claims, costs, damages, and expenses, and reasonable attorney fees arising out of, directly or indirectly, any claim of personal injury or death associated with such unintended or unauthorized use, even if such claim alleges that SCILLC was negligent regarding the design or manufacture of the part. SCILLC is an Equal Opportunity/Affirmative Action Employer.

PUBLICATION ORDERING INFORMATION

NORTH AMERICA Literature Fulfillment:

Literature Distribution Center for ON Semiconductor
P.O. Box 5163, Denver, Colorado 80217 USA
Phone: 303-675-2175 or 800-344-3860 Toll Free USA/Canada
Fax: 303-675-2176 or 800-344-3867 Toll Free USA/Canada
Email: ONlit@hibbertco.com
Fax Response Line: 303-675-2167 or 800-344-3810 Toll Free USA/Canada

N. American Technical Support: 800-282-9855 Toll Free USA/Canada

EUROPE: LDC for ON Semiconductor - European Support

German Phone: (+1) 303-308-7140 (M-F 1:00pm to 5:00pm Munich Time)

Email: ONlit-german@hibbertco.com

French Phone: (+1) 303-308-7141 (M-F 1:00pm to 5:00pm Toulouse Time)

Email: ONlit-french@hibbertco.com

English Phone: (+1) 303-308-7142 (M-F 12:00pm to 5:00pm UK Time)

Email: ONlit@hibbertco.com

EUROPEAN TOLL-FREE ACCESS*: 00-800-4422-3781

*Available from Germany, France, Italy, England, Ireland

CENTRAL/SOUTH AMERICA:

Spanish Phone: 303-308-7143 (Mon-Fri 8:00am to 5:00pm MST)

Email: ONlit-spanish@hibbertco.com

ASIA/PACIFIC: LDC for ON Semiconductor - Asia Support

Phone: 303-675-2121 (T-F 9:00am to 1:00pm Hong Kong Time)

Toll Free from Hong Kong & Singapore:

001-800-4422-3781

Email: ONlit-asia@hibbertco.com

JAPAN: ON Semiconductor, Japan Customer Focus Center

4-32-1 Nishi-Gotanda, Shinagawa-ku, Tokyo, Japan 141-8549

Phone: 81-3-5740-2745

Email: r14525@onsemi.com

ON Semiconductor Website: <http://onsemi.com>

For additional information, please contact your local Sales Representative

SMPSRM/D