

## **A Prototype Frequency Machine for Plasma Tube Research**

This document describes a prototype Frequency Machine which I have built for the purposes of Rife experimentation and other plasma tube research.

### **Disclaimer**

This machine is intended for experimental and research purposes only. It is not intended as a medical treatment device. The author makes no representations as to this kind of use and also does not accept responsibility in any way for how it is used by third parties or any consequences thereof.

### **General Description**

This machine is designed to power a standard phanotron type tube. It will work equally well with other types of plasma tube, however since it requires direct connection, the tube used must have internal electrodes. It has been built and tested successfully with a Nazarov type Helium filled Phanotron tube.

The output power of the circuit is variable and will provide between 60 and 480 Watts of power during normal operation. The efficiency is extremely high - in excess of 98%.

The machine will operate with two standard TTL level inputs. One being a carrier square wave of frequency between 100 KHz and 1.65 MHz, the other being a modulating square wave from approx 4Hz up to approx 40% of the carrier frequency (approx 200KHz in normal operation with a 500Khz carrier).

### **Warnings!**

This circuit develops extremely high voltages at its output terminals. Normal voltages of between 1.2KV and 1.8KV are to be expected - in some cases short spikes of up to 9KV can be produced. As such this circuit can be extremely dangerous and should only be built by qualified and/or experienced people.

This circuit is only a prototype. It does not contain many refinements and safety factors that might normally be expected in a circuit of this type. As such it is possible for the circuit to overload with a consequent fire risk unless it is attached to a well regulated and limited supply or unless it is well supervised in operation. Do not leave this circuit operating unattended!

Finally this circuit may generate large amounts of RF radiation, and in particular harmonic radiation that may violate radio emission regulatory codes. It should only be used in a shielded room.

### **Circuit Construction**

The construction of the circuit is quite simple. The two input IC's IC1 and IC2 are LS TTL devices and should be run from a regulated +5V power supply line. IC3 should be run from a separate +12V supply line - preferably independently of the main power feed to the MOSFET drive stage.

The two output MOSFETS Q1 and Q2 should be mounted on a heat sink. Choke L1 and possibly L2 as well should be mounted in a well ventilated position in case they get hot. In normal operation I have found that the circuit does not get hot at all for power throughputs up to the order of 220W and that power transmission from input to output is extremely efficient. The most critical component is the output transformer L2. This should be constructed by placing 80 turns of 1.25 mm diameter wire on a Siemens/EPCOS R58 Ferrite Toroid of N30 material. These 80 turns comprise the secondary winding of the transformer. The primary consists of 2 single turns of 2.0 mm diameter wire connected in a centre tap arrangement i.e. one turn either side of the centre tap, overwound on the secondary. The AL value of the recommended toroid core is 5400nH and so the inductance of the primary windings is approx 5.4uH.

I recommend winding a layer of glass fibre tape around the toroid before commencing winding, and also between the secondary and primary layers. This will protect the wire from irregularities on the core surface and also should help reduce interwinding capacitance.

The choke L1 is for suppression of noise fed back to the supply. The value is not too critical but the constructor should bear in mind that as it is a DC choke it may saturate and so should be constructed accordingly with regard to expected current flow etc. In my prototype it consists of 20 turns of 2.0 mm wire wound around approx 50mm of standard aerial type ferrite rod (also pre-wrapped in glass fibre tape).

The main input supply capacitor is a large 21000uF electrolytic type. Make sure you use a heavy duty capacitor rated for at least 63 volts and which will be able to stand high currents.

Connecting wires for the drain/source circuit should be heavy gauge wire of at least 2.0 mm diameter as this circuit can sink currents in excess of 30A.

The recommended output MOSFETS are designed for switch mode PSU operation (the whole circuit is very similar to a simple switch mode PSU) and will give excellent and reliable performance in this application. If you use alternative devices the circuit may not operate correctly - in particular pay careful attention to the current handling of the devices used and the input capacitance. These devices are also very cheap and will not be expensive to replace in the event of an overload. It is possible for the output transformer to saturate with consequent current overload and MOSFET destruction when very high average currents are used (i.e. in excess of 20A). A fuse should be fitted in the main drive supply line to help avoid this.

### **Circuit Operation**

The input XOR gate IC1 generates two square waves from the carrier input with 180 degree phase shift between them. IC2, a NAND gate allows the carrier to be chopped on and off with a second modulating audio signal at TTL levels. Note that the modulating pulse may use any duty cycle but the carrier MUST be a fixed 50% duty cycle square wave. If it is not, then the core will saturate due to current imbalance and the circuit will overload.

The output from IC2 goes to a TC4426 dual MOSFET gate driver which inverts the pulses and switches on the gates of the MOSFETS. The two antiphase signals result in the MOSFETS switching on alternately - each in turn drawing current in opposite directions

through the primary winding of the output transformer. Each current pulse through the output primary results in a current pulse in the secondary of the transformer. As the turns ratio of the output transformer is 80:1 the output voltage developed will be 80 times the input voltage. However since there are effectively two input windings (one for each MOSFET) the net output will actually be 160 times the input voltage. For an input voltage of 12V, a net output potential difference across the output terminals of approx 1.8KV may be expected. This is more than sufficient to fire a plasma tube.

There is no impedance matching of the transformer output to the plasma tube. This is not very critical at the frequencies in use. The output impedance of the transformer is approx 1350 ohms at 500Khz and so represents a reasonable match to an average tube in any event. In practice I have found the SWR and reflected power to be negligible. The output is balanced and floating and one end may be safely grounded if desired.

The circuit produces a bright, stable plasma in the tube. In practice I have found that it is necessary to control the power input to ensure that overloading does not occur. I recommend using a high power PSU capable of adjustable output voltage of between 6 and 12V DC and that has adjustable current limiting. The best way to use the circuit in practice is to start by applying approx 7V to the main power drive and then switching on the carrier/modulator circuit (with signals applied). This typically results in an average current draw of about 10A and is a good useable level for most Rife type experiments. The output power at this level will actually be 70 W average, but due to the fact that a 50% modulation actually has the power switched off half the time, the effective peak power will be approx 140W. The voltage may be increased for increased power.

I have found that the circuit works best if the modulating signal is also gated at low frequency (i.e. between 4 and 8Hz). This is because the power transfer will cause the tube electrodes to heat up rapidly. If the tube electrodes get sufficiently hot they will cause secondary thermionic breakdown in the plasma (due to thermionic emission from the heated electrodes) which in turn will start to drive the plasma from the glow discharge region into arc discharge. If the modulating signal is gated on and off at say 4Hz, this actually gives the electrodes time to cool between pulses and prevents the tube going toward arc discharge. However, if you are able to put a hard current limit on the input power then this will also prevent this from happening. The danger of such excessive current draws is that either it can cause burn up of the plasma tube or that it will cause saturation of the output transformer - which in turn will cause the output MOSFETS to overload.

In practice I have found that the core does tend to approach saturation at voltages of 12V and average current draws of 20A - since this represents a peak power of approx 480W this should not be major problem in normal use. Hopefully a 35A fuse in the main power feed line will prevent MOSFET damage in the event of an overload.

I would like to stress that this circuit is only a prototype and is not intended to be a finalised design, I am releasing details solely for the benefit of other researchers and experimenters who know what they're doing! If you don't understand how this circuit works then don't build it!

The circuit was designed to work with carriers in the range from 100KHz to 1700Khz. In practise it has been found to work well with carriers down to approx 36KHz. The upper limit is decided mostly by the inductance of the transformer and the circuit will not operate at

frequencies much above 2Mhz. My intention was to create a true variable carrier drive that would allow experimentation with the frequencies used in the Phillip Hoyland designed Rife Ray No 4 machine which used carriers from 139 Khz to 1.604 MHz. This circuit does work well across this range. For general experiments however I would suggest that a fixed carrier of approx 500-600Khz is the best operating range.

A bare carrier at 1.604 MHz will not be sufficient to light the tube. However as soon as any audio modulation is applied the current spike will be sufficient to cause the tube to light, and once lit it will continue to operate even with a bare carrier.

The output waveform across the plasma is mostly square modulation pulses consisting of rounded carrier square waves but which have high power spikes at both the leading and trailing edges of the modulation pulses. I believe this contributes greatly to bioactive effect.

One thing that is also worth mentioning is that I did not design in an interlock to prevent output driver cross conduction. I found that this was not necessary with the circuit as described but may be a desirable feature in future prototypes.

I hope this circuit will assist serious researchers. As I did not design this with amateur constructors or end users in mind please do not send me requests for additional features, PCB layouts etc., as I do not have time to accommodate such requests. However I will be happy to receive comments and any suggested improvements. My email address is [ascoon@postmaster.co.uk](mailto:ascoon@postmaster.co.uk)

Aubrey Scoon  
4 August 2001

This design and document is (C) Copyright Aubrey Scoon 2001. It may be freely distributed or posted on web sites without permission however please note that I retain all rights in respect of it and that the copyright notices should not be removed.

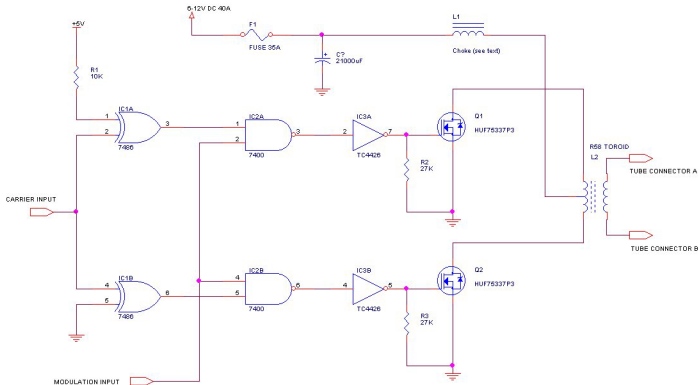

Title Frequency Instrument Prototype - (C) Copyright Aubrey Scoon 2001

Size A Document Number 1 of 1

Rev A

Date: Saturday, August 04, 2001 Sheet 1 of 1