

OWNERS MANUAL



Bearcat

50 Channel Crystalless Scanner Service Search Aircraft • Marine • Public Service

MONITORS VHF and UHF FM RADIO SERVICES

Hams	Utility Services	Special
Police	Industry	Disaste
Government	Business	School
Forestry	Hospitals	Transp
Conservation	Ambulances	Taxicat
Mobile Telephones	Automobile Emergency	Railroa
Press	Marine	Paging
Fire	Manufacturers	Trucks
Aircraft		

MANUFACTURED UNDER ONE OR MORE OF THE I
3,961,261 3,962,644 4,027,251 4,092,594
and patents pending



Electra Company
Division of Masco

300 East County Line Road
Cumberland, Indiana 46229

©1980, Masco Corporation of Indiana

LIMITED WARRANTY

This Bearcat® receiver is warranted to the original consumer purchaser to be free from defects in material and workmanship for a period of one (1) year from the date of purchase as shown on purchaser's receipt.

Electra will repair or replace, AT ITS OPTION AND FREE OF CHARGE, during the warranty period, any part which proves defective in material or workmanship under normal installation, use, and service, provided the receiver is returned to our factory (address below) or to one of our authorized Service Centers (list enclosed), TRANSPORTATION CHARGES PREPAID. Receivers returned to our factory or authorized Service Center must be accompanied by a copy of purchase receipt. In the absence of such purchase receipt, the warranty period shall be one (1) year from the date of manufacture as indicated by the serial number on your unit.

Any damage to this receiver as a result of misuse, abuse, neglect, accident, improper installation, destruction or alteration of the serial number, repair or alteration outside our factory or Service Center, or any use violative of instructions furnished by us WILL VOID THE WARRANTY. THIS WARRANTY IS LIMITED TO DEFECTIVE PARTS REPAIR AND/OR REPLACEMENT ONLY AND EXCLUDES ANY INCIDENTAL AND CONSEQUENTIAL DAMAGES CONNECTED THEREWITH.

Some states do not allow the exclusion or limitation of incidental or consequential damages, so the above limitation or exclusion may not apply to you.

This warranty gives you specific legal rights, and you may also have other rights which vary from state to state. In the event of a problem with warranty service or performance, you may be able to go to a small claims court, a state court, or a federal district court.



Electra Company
Division of Masco Corp. of Indiana

300 East County Line Road
Cumberland, Indiana 46229

TABLE OF CONTENTS

Radio Services	Front Cover	Time	13
Table of Contents	1	Priority	13
Technical Specifications	2	Auxiliary	13
General Description	3	Count	14
Safety Precautions	3	Delay	14
Safety Instructions	4, 5	Programmed Search	15
Operating Instructions	6	Service Search	16, 17
Front Panel Controls	7	Auxiliary Function	17, 18
Display Features	9	External Antenna	19
Programming Frequencies	10	External Speaker	19
Direct Channel Access	11	Mobile Installation	19, 20
Channel Banks	11	Useful Hints	21, 22
Scanning	11, 12	Service	23
Lockout	12	Birdies	23
Speed	12	Frequency Allocations	24-26
Dim	12	Warranty	Back Cover



Certified in accordance with
FCC Rules and Regulations
Part 15.63 as of date of
manufacture.

CAUTION

TO PREVENT FIRE OR SHOCK
HAZARD, DO NOT EXPOSE THIS
APPLIANCE TO RAIN
OR MOISTURE.

For future reference, write the model number and serial number below. You will find them printed on the back of your radio.

Model No. _____ Serial No. _____

Purchased from: _____ Date _____

TECHNICAL SPECIFICATIONS*

Size:	12 1/4"W x 4"H x 7 1/4"D
Weight:	6 lbs.
Cabinet:	Painted texture steel or vinyl-clad steel
Power Requirements:	117Vac, 20W 13.8Vdc, 9W
Antenna:	Telescoping whip (supplied) Connector provided for external antenna (50-70 ohms)
Clock:	Crystal-controlled, vacuum fluorescent display of hours, minutes, seconds. Keyboard-resettable
Frequency Coverage:	Low Band 32-50MHz Aircraft 118-136MHz 2-Meter Amateur 144-148MHz High Band 148-174MHz 70 CM Amateur 421-450MHz UHF Band 450-470MHz UHF-T Band 470.0125-512.0125MHz
RF Sensitivity:	0.4uV 32-50MHz 0.4uV 144-174MHz 0.8uV 421-512MHz (±3KHz deviation 12db SINAD) 1.0V for 10db S/N Aircraft 60% mod.
Squelch Sensitivity:	Equal or better than specified RF sensitivity
IF Selectivity:	-60db @ ± 25KHz
Scan/Search Speed:	Selectable 5 or 15 channels per second
Scan/Search Delay:	Selectable 0 or 2 seconds
Audio Output:	2.5 Watts RMS, 8 ohms. 10% THD (max.)
Auxiliary Output:	Will switch 500 ma. d.c. (max. sink) external load
Front Panel Controls:	Volume (on/off) Squelch (Auto Squelch) Display Keyboard
Rear Apron Connectors:	13.8Vdc 117Vac External Antenna External Speaker Tape Output Auxiliary Control Terminal Ground Terminal

*Specifications are typical and subject to change without notice.

GENERAL DESCRIPTION

Your Bearcat 300 is a 50-channel, automatic VHF/UHF FM and aircraft AM scanning radio receiver. Its micro-processor control makes scanning easy. The advanced search feature allows unknown signals to be captured and monitored, and their frequencies can be manually stored in memory for later recall. The versatile keyboard will allow you to command a variety of convenient functions: digital display of frequencies and channel numbers, direct channel access, scan or manual control, lockout of unwanted channels, priority for important transmissions, programmable search, service search, selectable speed control for both scan and search., and even local time . . . to the second!

An internal dual power supply allows 117Vac or 13.8Vdc operation. Additional features include external antenna jack, external speaker jack, tape output jack, auxiliary connector, volume and squelch controls, a large, bright display panel, frequency synthesis requiring no channel crystals, and track-tuning.

SAFETY PRECAUTIONS

Although your Bearcat 300 is listed with Underwriters Laboratories for complying with standards of safety, a review of common precautions is recommended:

Do not operate this unit if it is wet.
Never touch an electrical appliance while standing in water or on wet ground.
Do not tamper with the internal circuitry.
Do not connect or disconnect the rear-apron power connector when the line cord is plugged into an ac receptacle.

If you suspect an electrical problem exists, refer to the warranty instructions and return your receiver immediately to Electra for inspection. Use the original packing carton for secure shipment.

SAFETY INSTRUCTIONS

Read SAFETY INSTRUCTIONS before operating the radio. Save the SAFETY INSTRUCTIONS for future reference.

Warnings on the radio and instruction manual are for your safety. Operating and use of instructions should be followed to achieve full satisfaction from your radio.

The radio should be connected only to a power source of the type described in the instruction manual and as marked on the radio. Power cords should be routed so that they are not likely to be walked on or pinched. The ac power cord is provided with a gripper for ease in removal from the wall outlet. The power cord should be inspected occasionally for damage.

The radio should be situated so that its location does not interfere with its proper ventilation, and placed away from heat sources such as radiators, heat registers, and other appliances that produce heat. The radio should be used only with a cart or stand recommended by the manufacturer. The radio should be mounted to a wall or ceiling only as recommended by the manufacturer.

The radio should not be operated near water - for example, a wet basement, kitchen sink, or near a swimming pool.

The power cord should be unplugged from the outlet when left unused for a long period of time. Also remove batteries (if used).

Care should be taken so that objects do not fall and liquids are not spilled into the radio.

Damage Requiring Service - the radio should be serviced by qualified service personnel when:

- A. The power supply cord or the plug has been damaged; or
- B. Objects have fallen, or liquid has been spilled into the radio; or
- C. The radio has been exposed to rain; or
- D. The radio does not appear to operate normally or exhibits a marked change in performance; or
- E. The radio has been dropped, or the enclosure damaged.

Servicing - the user should not attempt to service the radio beyond that described in the operating instructions. All other servicing should be referred to qualified service personnel.

Cleaning - radios should be cleaned using a damp cloth.

SAFETY INSTRUCTIONS (Cont'd.)

Outdoor Antenna Grounding - Many of the Bearcat radios have provisions for connection to an outside antenna. An outside antenna should be located away from power lines. The antenna system must be grounded to provide protection against voltage surges and built up of static charges. The antenna system should be installed only by qualified service personnel. Section 810 of the National Electric Code, ANSI/NFPA No. 70-1978 provides information with respect to proper grounding of the mast and supporting structure, grounding of lead-in wire to an antenna discharge unit, size of grounding conductors, location of antenna-discharge unit, connection to grounding electrodes, and requirements for the grounding electrode.

EXAMPLE OF ANTENNA GROUNDING AS PER NATIONAL ELECTRICAL CODE INSTRUCTIONS

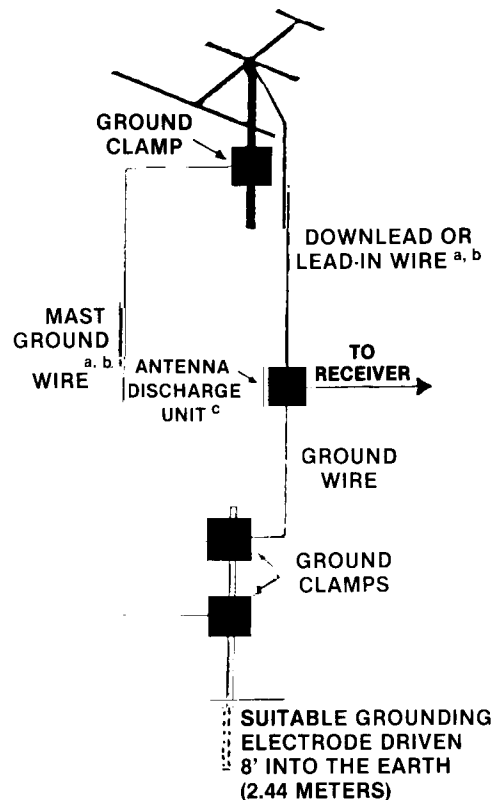

^a Use No. 10 AWG copper or No. 8 AWG aluminum or No. 17 AWG copper-clad steel or bronze wire, or larger as ground wires for both mast and lead-in.

^b Secure lead-in wire from antenna to antenna discharge unit and mast ground wire to house with stand-off insulators, spaced from 4 feet (1.22 meters) to 6 feet (1.83 meters) apart.

Mount antenna discharge unit as closely as possible to where lead-in enters house.

OPERATING INSTRUCTIONS

By reading this section carefully, you can be using your new scanner within minutes. Follow the sequence of directions to avoid confusion.

1. After unpacking the unit from the carton (save the carton for possible future use), check your Bearcat 300 for shipping damage; if damage has occurred, contact your dealer immediately per the warranty instructions.
2. First insert the ac power cord into the connector provided on the rear apron of your scanner. Plug the cord into a 117Vac outlet (mobile installation will be discussed later).
3. Insert the threaded end of the telescoping whip antenna (provided) into the hole on the top of the scanner. Screw it in clockwise finger-tight, and extend it fully.
4. Turn the scanner ON by turning the VOLUME control clockwise approximately 1/3 of its rotation. The volume control is used in the conventional manner to adjust the sound to a comfortable listening level.
5. Rotate the squelch control fully counter-clockwise until it switches into AUTOMATIC. This factory-set circuit permits the receiver to automatically turn off, or mute, irritating background noise while instantly responding to desired signals.

(For very precise manual squelch adjustment, rotate the control clockwise until you hear the background "hiss" then turn the control back until the noise just disappears again. This is the most sensitive setting for the squelch control.)

Your radio is now in the "first power-on" condition. The status of various features is as follows:

- A . It is scanning at fast speed as indicated by the rolling display.
- B . The first bank (channels 1 thru 10) is selected.
- C . Priority is inactive; Search Limits are cleared.
- D . The clock started at 0:00:00 and is not set accurately. An "E" will show in the 6th position when "TIME" is selected.

NOTE: The above condition will exist any time the radio is unplugged or power is interrupted. Lockout, Delay, Aux., and Count are retained in a non-volatile memory along with programmed frequencies.

You may hear local signals at this time only if the factory test frequencies are active in your area.

You will learn how to program your Bearcat 300 with local frequencies shortly.

FRONT PANEL CONTROLS

ON/OFF VOLUME: Turns the receiver ON and OFF and adjusts the sound level.

- SQUELCH:** Keeps the radio quiet unless a signal is being received and allows the radio to scan or search for a signal.
- AUTO SQUELCH:** A convenient, fixed squelch setting.
- DISPLAY PANEL:** Indicates Channel Number, Frequency, Delay (d), Lockout (L), Scanning action (rolling zeros or L in locked out channels), Programming Error (Error), Time, Time Error (E), Priority (P), Channel Banks (*) Aux. (.).
- KEYBOARD:** Transfers fingertip commands to the Bearcat Micro-Processor.



PROGRAM KEYS

0 thru **9** and **.** used to put frequencies into the scanner.

E enters frequencies into scan channels from keyboard or from search display.

SCANNING CONTROLS

10 - 50 five banks (10 channel each) are each included or excluded for a maximum of 50 channels.

Scan starts SCAN of all selected channels.

Manual Single-steps receiver through all 50 channels; stops search or scan; prepares the radio for any mode of operation.

Speed selects SCAN or SEARCH rates of 5 or 15 channels per second.

Count indicates the number of times the displayed channel has received a signal.

FEATURE CONTROLS

Lockout locks out displayed channel during SCAN only.

Delay selectively activates a 2-second delay to receive a reply transmission.

Priority samples channel 1 every two seconds and automatically switches to any signal on channel 1 regardless of any other signals.

Time displays TIME when radio is ON or OFF (if selected).

Aux. selectively activates AUX. OUT on rear panel.

Dim dims/brightens display.

SEARCH CONTROLS

Limit enters two selected frequencies as upper and lower limits for programmed search.

Search starts programmed search operation.

Police-Air selects or de-selects the specified service search function.

LO selects or de-selects Low band for Service Search.

HI selects or de-selects High band for Service Search.

UHF selects or de-selects UHF band for Service Search.

Hold stops programmed or Service Search operation. manually increments programmed or Service Search.

Resume continues programmed or Service Search operation.

DISPLAY FEATURES

The BC300 display consists of 11 digit spaces or "windows" in which lighted characters indicate the programming commands of the keyboard. The display of features selected or de-selected is shown below:

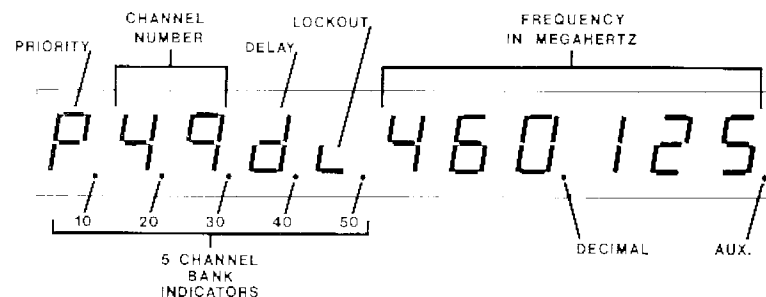

In this example, from left to right, the following information is shown:

All 5 CHANNEL BANKS are selected as indicated by dots at lower right of spaces 1-5.

PRIORITY is ON (P in 1st space)

Channel 49 is selected (in 2nd and 3rd spaces)

DELAY is selected (in 4th space)

LOCKOUT is selected (in 5th space)

The FREQUENCY 460.125MHz (6th thru 11th spaces) is programmed into channel 49.

AUX. is selected as indicated by the dot in lower-right of 11th space.

PROGRAMMING YOUR RECEIVER

Read this section thoroughly before attempting frequency programming.

Now that you are aware of some of the flexibility of your Bearcat 300, you are ready to enter local frequencies.

You can program your receiver to scan 50 different frequencies, one for each of the 50 channels, arranged in 5 groups of 10 channels each.

EXAMPLES

To program 162.550MHz in desired channel (for example channel 25):

PRESS: **Manual** step to desired channel (25)
 PRESS: **1** **6** **2** **.** **5** **5** **E**
 READ: 25 162.550
 PRESS: **Manual** step to next channel (26)

To program 471.1375MHz in next channel (26):

PRESS: **4** **7** **1** **.** **1** **3** **7** **5** **E**
 READ: 26 471.137 (Rounded off to 6 places)

This manual selection of channels may continue through all fifty channels, even without all channel banks having been pressed.

If you attempt to program a frequency that is outside the tuning range of the receiver, "Error" appears on the display, and you simply enter a new frequency.

If you make a mistake on one channel

PRESS: **E** then program correct number.

An alternate method is to

PRESS: **.** twice which erases the mistake and returns to previous channel frequency.

DIRECT (MANUAL) CHANNEL ACCESS

To display any channel (Example: 37) when Scanning or manual operation

PRESS:
READ: 37 in 2nd and 3rd spaces along with frequency and status information.

The "Manual Mode" may be selected at any time by pressing . All of the 50 channels may be displayed in sequence by repeated pressing of the key.

BANKS OF CHANNELS

The first bank of channels was automatically selected upon "First Power-on" and was indicated by the dot in lower right of the 1st space. After programming the first 10 channels, continue programming by:

PRESS: Bank Key. A dot appears in the 2nd space.
PRESS: 11 appears as the channel No.
Continue programming channels 11 thru 20.
Repeat above procedure for banks 30, 40 and 50.

Any bank may be de-selected, or omitted from scanning, by pressing the corresponding key. For example to de-select the bank containing channels 41 thru 50:

PRESS: Bank Key. The dot in space 5 will disappear.

If all banks are de-selected, Bank 10 is automatically re-selected.

SCANNING

To put your receiver in the "Scanning Mode", adjust the squelch properly (see Page 4). Then:

PRESS:
READ: Rolling Zeros in the 10 right-most spaces of the display.
The Bank Indicator Dot for the bank being scanned at that instant.
Lockout Symbols (L) (instead of zeros) representing the channels being skipped.

When a signal is received on a channel (not locked out) the scanning will stop and the display will show:

- the selected banks
- the channel number being received
- the frequency being received

To stop scanning

PRESS:

LOCKOUT

You may wish to lock out certain frequencies in any bank and skip over them when scanning. To program Lockout on a channel (Example: 37) first select that channel manually.

PRESS:
PRESS:
READ: 37 (L) (lockout symbol appears on this channel)

To remove Lockout

PRESS: The symbol "L" will disappear from this channel.

SPEED

To scan slowly or rapidly (5 or 15 channels per second)

PRESS: To resume fast scan PRESS:

DIM

To dim display

PRESS:
To return to brighter display
PRESS:

TIME

To display time from the 12-hour clock, go to the Manual Mode first. Then:

PRESS: **Time** The display shows hours, minutes and seconds. If an "E" appears, power has been interrupted and the clock should be reset.

To set the clock to 9:02:03 when in the TIME mode

PRESS: **0** **9** **0** **2** **0** **3** **E** and Read: 9.02.03
NOTE: All six digits must be entered.

You may also scan or search with the time and channel number being displayed.

To remove time from the display: PRESS: **Time**

To display time when the switch is turned "OFF", PRESS: **Time**

PRIORITY

This selectable feature will permit you to hear channel 1 any time it is active, regardless of any other signals being received at that time. Put your favorite frequency in channel 1. Then:

PRESS: **Priority** "P" is displayed
To de-select Priority
PRESS: **Priority** again. "P" disappears

AUXILIARY

To selectively control accessories attached to the Auxiliary terminal on the rear apron, go to the desired channel manually. Then:

PRESS: **Aux.** Dot appears at lower-right of display.
To de-select Auxiliary
PRESS: **Aux.** Dot disappears.

See "Auxiliary Function" section on Page 15.

COUNT

To count the number of times a channel has received a signal (up to 99), go to that channel manually, for example, 34:

PRESS: **3** **4** **Manual** Channel 34 is displayed
PRESS: **Count** The count number will show at the right end of the display.

To erase count from memory

PRESS: **Count** The count number is displayed
PRESS: **.** (Decimal Point), channel and frequency are displayed
PRESS: **Count** counter will display 00

To return to manual without erasing count

PRESS: **Count**

DELAY

Your scanner may be programmed to pause for about two seconds after a transmission on any selected channel. This is useful when both sides of a conversation are transmitted on the same frequency.

To program Delay on a selected channel

PRESS: **Delay** The "d" will be displayed. The channel will hold for 2 seconds after the signal ends.
To de-select delay
PRESS: **Delay** The "d" disappears. Scanning will begin immediately at the end of the signal.

Delay will also hold for 2 seconds in Search, if such a delay is desired.

PROGRAMMED SEARCH

To search for signals continuously between two frequencies in the same band (example: 160.000MHz to 161.000MHz), go to any desired channel manually (example 37). Then:

PRESS:	<input type="text" value="1"/>	<input type="text" value="6"/>	<input type="text" value="0"/>	<input type="text" value="Limit"/>
READ:	37	160.000 (one limit is entered)		
PRESS:	<input type="text" value="1"/>	<input type="text" value="6"/>	<input type="text" value="1"/>	<input type="text" value="Limit"/>
READ:	37	161.000 (other limit is entered)		

To start search

PRESS:	<input type="text" value="Search"/>	The search frequency will be displayed and incrementing
--------	-------------------------------------	---

To stop search

PRESS:	<input type="text" value="Hold"/>	The search frequency will be displayed.
--------	-----------------------------------	---

To increment search manually

PRESS:	<input type="text" value="Hold"/>
--------	-----------------------------------

To resume search on this channel

PRESS:	<input type="text" value="Resume"/>	Search will continue.
--------	-------------------------------------	-----------------------

To resume search on another channel without changing search limits, step to the desired channel and:

PRESS:	<input type="text" value="Search"/>
--------	-------------------------------------

To enter a frequency, found while searching, into the channel on which you are searching:

PRESS:	<input type="text" value="E"/>	Then manually go to the next channel you want to use and PRESS:	<input type="text" value="Search"/>
--------	--------------------------------	---	-------------------------------------

NOTE: Any power interruption will cause the programmed search limits to be erased. The limits will have to be re-entered. Turning the radio "OFF" does not interrupt the power to the Micro-Processor and will not erase the search limits.

SERVICE SEARCH

NOTE: IF SEARCH or SERVICE SEARCH is used on Channel 1, subsequent use of PRIORITY can cause change in program on Channel 1. This does not occur on any other channel.

The Bearcat 300 is pre-programmed with over 2100 active frequencies in memory. Service Search arranges these in eleven service categories, in accordance with FCC frequency assignments, for immediate access to any given interest category. The services and frequency bands used are listed below.

SERVICE	BAND	
	UHF	LO VHF
Police	X	
Fire	X	
Marine		
Ham	X	
Emergency	X	X
Telephone	X	
Government	X	X
Forestry Service		X
Industrial	X	X
Transportation	X	X
Aircraft		X

To use Service Search:

PRESS:	<input type="text" value="Manual"/>
--------	-------------------------------------

Then press desired service key. The appropriate LED will light.

The 5th space in the display indicates the frequency bands being searched.

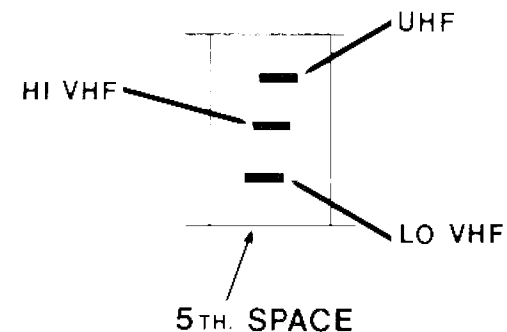

NOTE: The Aircraft Band will indicate LO VHF.

To eliminate Service Search on UHF, HI VHF, or LO VHF ranges

PRESS: **UHF** , **HI** or **LO**

To restore Service Search on ranges previously eliminated

PRESS: **UHF** , **HI** or **LO** again.

To stop during service search, PRESS: **Hold**

To manually advance Service Search, PRESS: **Hold**

To resume Service Search, PRESS: **Resume**

To enter a Service Search frequency into a channel, PRESS **E** .

NOTE: Service search mode of operation is cancelled when any of the following keys are pressed **Manual** , **Scan** , **0** thru **9** .

NOTE: Although most active frequencies are in the 11 Service Search categories, there will be some active frequencies in many areas which are not included. These may be programmed into the 50 user-programmable channels.

AUXILIARY FUNCTION

When the auxiliary function is activated selectively on a channel, (PRESS: **Aux.**) a dot will appear at the lower-right corner. Each time the scanner detects a signal on this channel, the AUX. terminal on the rear apron of your Bearcat 300 will provide a closed circuit of up to 500 milliamperes of current. This will turn on many remote controlled battery-operated cassette recorders without additional accessories. NOTE: Some recorders may require additional interface equipment for control or audio. This should be installed by a qualified technician.

Audio for the recorder input is provided by: The External Speaker jack which will disconnect the internal speaker for silent recording; or the Tape jack which allows the speaker to remain on for audible monitoring while recording.

One connection of the tape recorder is made in the following manner.

1. Turn the radio off and unplug it from the wall receptacle.
2. Connect the control wires from the cassette recorder "Remote" jack to the AUX. and GND. terminals as shown in Fig. 1. If the recorder, set to "play", starts with the receiver OFF, the wires should be reversed. NOTE: Recorder should not be grounded to radio or other device in any manner.

3. Plug in radio, turn it ON. With the recorder set to operate, step the BC-300 to a channel programmed for aux. control (PRESS: **Aux.**). Receive a signal (or open the squelch) and the recorder should be activated.
4. Connect the Tape output of the BC-300 to the "mic" input of the recorder as shown in Fig. 1. To isolate the recorder ground from the scanner, coupling capacitors should be used in the ground and center conductors as shown. **Alternate:** Sound may be recorded by placing the microphone near the receiver speaker if preferred.
5. Adjust the BC-300 volume control to proper recording level.

To de-activate the Aux. function

PRESS: **Aux.** again.

The aux. control terminal will source 9 ma. and sink 500 ma. It is protected against reverse voltages. The internal circuitry is shown in Fig. 2.

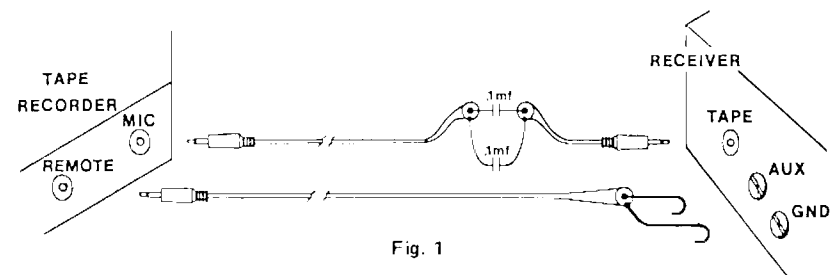

RECORDER HOOK-UP

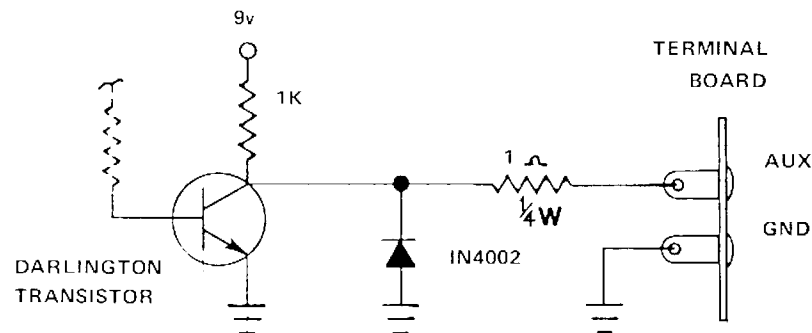

INTERNAL AUX. CONTROL CIRCUITRY

EXTERNAL ANTENNA

The telescoping antenna provided with your Bearcat 300 is recommended for most monitoring. For weak-signal reception, or for electrically-noisy locations, an appropriate external antenna designed for multi-band coverage should be connected to the unit via coaxial cable. RG-58U is recommended for lengths of up to 50 feet. For longer lengths RG-8U is recommended.

Your Bearcat 300 is equipped with an automotive type of external antenna jack, and a mating plug (supplied) must be used.

An outside antenna needs only to be high enough to clear surrounding obstructions. Above all, **STAY AWAY FROM POWER LINES!** You may be killed upon contact of the antenna with a power line.

EXTERNAL SPEAKER

Although the internal speaker of the scanner will provide ample room volume, in some applications an external speaker such as the Bearcat B-45 may be desired. The external speaker should be plugged into the rear-apron jack which will cut off the internal scanner speaker.

MOBILE INSTALLATION

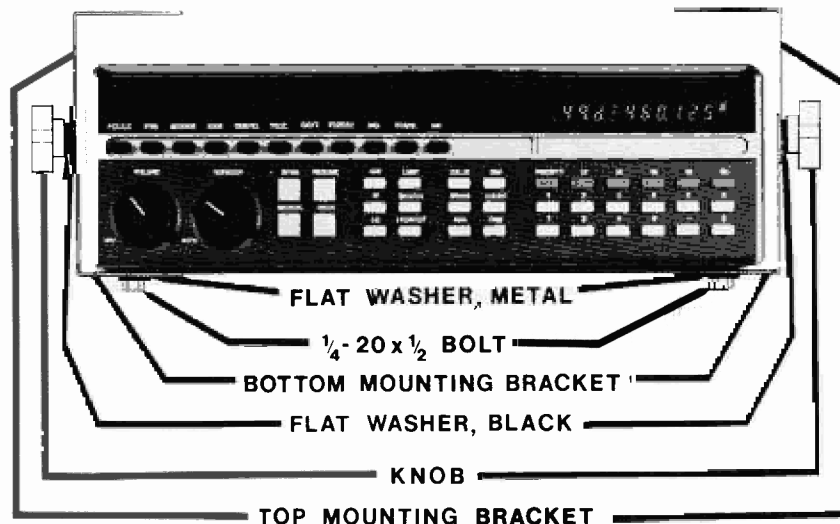

In some areas, unauthorized mobile police receivers are unlawful; be sure to check with local authorities before installing your unit.

Your Bearcat 300 may be installed in any vehicle or boat which has a 12-volt, negative-ground electrical system.

1. Assemble the mobile mounting brackets and attach to the scanner as shown on page 19.
2. Select a location under the dash to hold the scanner and mark the location for two mounting holes on **each** of the top brackets. Drill the four mounting holes using a 7/64 drill bit.
3. Remove the brackets from the scanner by removing the two bolts securing the bottom brackets. Secure the top brackets to the dash using two #6 self-tapping screws (provided) for each bracket.
4. Mount the scanner with the two bolts and flat washers through the bottom brackets.
5. Tilt the scanner to the desired position and tighten the knobs.
6. Connect the dc power cable to the insulated terminal on the rear apron of the receiver; attach the other end of the cable to the "accessory" or "radio" terminal on the vehicle fuse block.

Because the scanner continues to drain battery current (about 1/4 amp), even after being turned off, the power lead should be attached to one of the fuse circuits which is disconnected by the vehicle ignition switch.

Be sure the radio cabinet is well-grounded to the car metal through the mounting frame; otherwise, connect a piece of wire from the ground screw on the rear apron of the radio to the metal body of the vehicle.

Because power to the scanner is interrupted by turning off the vehicle ignition switch, your clock will have to be re-set each time you restore power. It will "power up" scanning fast, no priority and bank 10 selected.

7. Connect an appropriate mobile monitor antenna designed for multi-band coverage to the scanner. If necessary, the automotive antenna, extended about 18 inches, can be used with fair results.

USER HINTS

Your scanner is a versatile instrument. The following operating hints will help you use all its features:

1. Always remember when programming, the **E** key must be depressed in order to enter the frequency desired.
2. If you make a mistake during any programming steps, simply press **E** and start again. See programming frequencies on Page 8 for alternate method.
3. When programming, be sure to press each key firmly in the center—this assures registering each desired number and avoid errors.
4. Never turn the radio OFF by pulling the AC cord from the wall socket. Always turn the ON/OFF volume control OFF first, then disconnect the line cord when you must move the radio.
5. When frequency-programming VHF high band and UHF, you may ignore **decimals and final zeros**; they will be entered automatically. Thus, program 162.550 as 16255. Decimals must be used, however, in low band.
6. Write your programmed channels and matching frequencies on a sheet of paper to avoid the frustration of trying to remember what was programmed on a particular channel if it is accidentally erased. If memory is lost, it is corrected simply by reprogramming the desired frequencies.
7. When very weak signals are being received, their marginal nature will sometimes allow the search or scan to resume before the transmission is complete. This may be remedied by advancing the squelch control manually to slightly below the noise threshold (its most sensitive setting).
8. During search, it is likely that some strong signals will lock in before they are on center-frequency (e.g. weather may be received on 162.545 rather than the correct frequency 162.550). This is often detectable by a raspy, distorted voice quality. Simply press the **Resume** button to allow it to step another increment, and note an improvement in quality or signal strength. The actual signal frequency may be read at the higher-quality (and stronger-sounding) setting. Often, reducing the squelch sensitivity will minimize early lock-in during search.
9. This receiver has high noise immunity because of the quieting squelch system. However, in cases of strong interfering noise or signals, it may be desirable to reduce the length of the antenna to reduce noise pick-up below a critical level. This may be very effective in medium and strong signal areas.
10. If priority is already in use, or if you don't wish to use that function, you may still provide preferred scanning to certain highly-desirable channels by inserting the **same frequency into several channels**, so that it is scanned more often.

11. When moving or shipping the radio, remove the telescoping antenna to avoid damage to it or to the internal circuit assemblies.
12. **CHANNEL BANKS:** Because of the large storage capacity (50 channels) of your Bearcat 300, a system of filing has been provided so that you may selectively activate or de-activate sets of programmed frequencies in groups of ten. This not only speeds up scanning time (when unwanted banks are de-activated), but permits you to group categories of monitoring. For example, you may wish to program your scanner with these services:

10	1-10	Police
20	11-20	Fire
30	21-30	Press
40	31-40	Mobile Telephone
50	41-50	Marine

Each bank of channels may be randomly inserted or removed from the scanning sequence at any time merely by pressing the appropriate bank key. It is **not** possible to remove all five banks, as the first bank will resume automatically.

A dot will appear in each of the first five display spaces indicating which bank is being scanned.

13. **DELAY:** When the receiver is scanning or searching, it will remain on one particular frequency or channel as long as a signal is being received. As soon as the signal goes off the air, the scan or search resumes. Also, if it is a "Duplex" channel you will want to scan quickly to the next channel which you may have programmed to receive the reply. If a repeater is being monitored, the signal usually stays on the air long enough for both sides of the conversation to be heard. **However** many transmissions are "simplex": Both transmitters are on the same channel. By pressing **Delay** while the frequency or channel is displayed, a two-second pause will occur after the signal goes off the air before the receiver resumes its scan or search function. This is usually long enough for a replying communication to be heard.

To de-activate the delay command, press **Delay** a second time while on that channel.

SERVICE

If your scanner does not seem to be functioning properly:

1. Refer to operating instructions to confirm that the proper procedure for operation has been followed.
2. Be sure the radio is plugged into a working ac outlet.
3. Is it turned ON?
4. Check that the telescoping antenna is properly installed.
5. If "Error" appears on readout, you have entered an invalid frequency.
6. While using the single key-press **Aircraft** Service Search, "image" interference from ham repeaters, cab dispatch, mobile telephone, etc. may stop search. This may be unavoidable in your area and does not indicate failure of the radio.
7. If it is then determined that the receiver requires servicing, refer to the warranty instructions enclosed with your unit for the proper repair facility.
8. When preparing the receiver for shipment, **remove the telescoping antenna, and ac power cord.**
9. Pack the unit in its original packing carton and include a brief, concise description of the observed problem you are having along with your name, address, phone number and a copy of your purchase receipt.

BIRDIES

All scanners using frequency synthesized circuits generate signals called "Birdies". Those signals may interfere with the search frequencies on your scanner. Slight adjustment of the squelch control can minimize the interference. Although the BC-300 is relatively free of this problem, some birdies do exist and may vary slightly in different radios.

If during Search the receiver encounters a "birdie", the scan will most likely stop. In order to resume searching just press the

Resume button.

The following is a list of strong "birdie" frequencies:

32.93MHz	39.865
33.80	41.60
37.265	44.20
38.13	45.065
39.00	45.93

FREQUENCY ALLOCATIONS

Because of the short-range nature of VHF and UHF FM communications, frequencies allocated to services in one geographical location will not be heard more than 25-50 miles distance (an exception is "skip", when signals bounce back to earth from the ionosphere). For this reason, a separate frequency directory must be compiled for each monitoring area.

Most standard frequency separations and classifications are regulated in the United States by the FCC.

Block allocations . . . and even some discrete frequencies . . . covered by the Bearcat 300 are shown below.

ABBREVIATIONS		34.00 - 35.00	Govt.
		35.02 - 35.18	Bus.
Police	P.D.	35.22 - 35.66	Mob. Tel. & Page
State Police	St. P.D.	35.70 - 35.73	Bus.
Fire Department	F.D.	35.74 - 35.98	Sp. Ind. & Bus.
Special Emergency	Sp. Emer.	36.00 - 37.00	Govt.
Highway Maintenance	Hwy.	37.02 - 37.44	P.D. & L. Govt.
Forestry-Conservation	Fors. Cons.	37.45 - 37.86	Power
Government	Govt.	37.90 - 37.98	Hwy. & Sp. Emer.
Local Government	L. Govt.	38.00 - 39.00	Govt.
Business Radio	Bus.	39.02 - 39.98	P.D., L. Govt.
Manufacturers	Mfg.	40.00 - 42.00	Govt.
Broadcast Remote	BC R.	42.02 - 42.94	St. P.D.
Mobile Telephone	Mob. Tel.	42.96 - 32.18	Sp. Ind. & Bus.
Radio Paging	Page.	43.22 - 43.68	Mob. Tel. Page
Special Industrial	Sp. Ind.	43.70 - 44.60	Trucks, Bus.
Motion Picture	Mot. P.	44.62 - 45.06	St. P.D., For. Cons.
Power Utilities	Power	45.08 - 45.66	P.D.
Petroleum	Pet.	45.68 - 46.04	P.D. Hwy., Sp. Emer.
Forest Products	For. Prod.	46.04 - 46.50	F.D.
Railroad	R.R.	46.52 - 46.58	L. Govt.
Automobile Emergency	Auto Emer.	46.60 - 47.00	Govt.
Red Cross		47.02 - 47.40	St. Hwy. 47.42 Red Cross
U.S. Weather Bureau	U.S.W.B.	47.44 - 47.68	Sp. Ind., Sp. Emer.
U.S. Coastal & Geodetic Survey	U.S.C.G.S.	47.70 - 48.54	Power
National Parks	Nat. Pk.	48.56 - 49.58	For. Prod., Pet.
Indian Affairs		49.60 - 50.00	Govt.
Bureau of Reclamation	Bur. Recl.	146 - 174MHz Band	
Department of Agriculture & Forestry	Agr. & For.	146.000 - 148.000	HAM
Land Transportation	Land Tr.	148.010	MARS
		148.15	CAP
		148.155 - 148.250	MIL
		148.290 - 150.750	USN
		150.815 - 150.995	Bus.
		151.010 - 151.130	Hwy.
		151.145 - 151.475	For. Cons.
		151.505 - 151.595	Sp. Ind.
		151.625 - 151.955	Bus.
		151.985 - 152.240	Mob. Tel. (RCC)
		152.270 - 152.450	Taxi
		152.480 - 152.840	Mob. Tel. Page
		152.870 - 153.020	Sp. Ind. Mot. P.
		30.01 - 30.56	Govt.
		30.56 - 30.62	Sp. Ind.
		30.66 - 31.24	Ind. (Pet. For. Cons. Bus., For. Prod.)
		31.26 - 31.98	Sp. Ind., For. Cons.
		32.00 - 33.00	Govt.
		33.02 - 33.16	Hwy., Sp. Emer., Bus.
		33.18 - 33.38	Pet.
		33.42 - 33.98	F.D.

NUMERICAL LISTING OF VHF MARINE RADIOTELEPHONE CHANNELS

153.050 - 153.440	Pet., For. Prod.
153.470 - 153.710	Power
153.740 - 154.115	L. Govt.
154.130 - 154.445	F.D.
154.450 - 154.600	Sp. Ind., Pet., Bus.
154.655 - 155.145	P.D., L. Govt., St. P.D.
155.160 - 155.400	Sp. Emer., P.D.
156.045 - 156.240	Hwy., P.D.
156.275 - 157.425	Marine
157.456 - 157.500	Auto Emer.
157.530 - 157.710	Taxi
157.740 - 158.100	Mob. Tel., Page
158.130 - 158.460	Power, For. Prod., Pet.
158.490 - 158.700	Mob. Tel. (RCC)
158.730 - 158.970	P.D., L. Govt.
158.985 - 159.210	P.D., Hwy.
159.225 - 159.465	For. Cons.
159.510 - 160.200	Trucks
160.215 - 161.565	R.R.
161.600 - 162.000	Marine
162.026 - 162.175	Bur. Recl.
162.400	U.S.W.B.
162.475	U.S.W.B.
162.550	U.S.W.B.
163.125	Indian Affairs
163.175	Bur. Recl.
163.275	U.S.W.B.
163.388 - 163.538	MIL
163.825 - 163.975	Govt.
164.025 - 164.075	U.S.C.G.S.
164.175 - 165.188	Bur. Recl., Nat. Pk., Govt., Agr. & For.
169.300	F.A.A.
169.450 - 169.725	Ind., Data
170.150	F.D., BC. R.
170.200 - 170.220	U.S.C.G.S.
170.225 - 170.325	Ind., Land Tr.
170.425 - 170.575	For. Cons.
170.975 - 171.250	Govt. Ind., Land Tr.
171.388 - 172.725	Bur. Recl., For. Cons., Ind., Dept. Ag & For., Govt.
172.775	Nat. Pk.
173.025	U.S.W.B.
173.075	U.S.C.G.S.
173.204	Press Relay, Mot. P., Pet., Bur. Recl.
420-512MHz Band	
420.000 - 450.000	HAM
451.050 - 450.950	Remote Br.
451.000 - 451.150	Util.
451.175 - 451.750	For. Prod., Pet., Pwr., Tel. Maint.
451.775 - 451.975	Spec. Ind.
452.000 - 452.500	Taxi, Mot. Carrier, R.R.
452.525 - 452.600	Auto Club
452.625 - 452.975	Motor Carr., R.R.
453.000 - 453.975	L. Govt., P.D., F.D.
454.000 - 454.975	
454.000 - 454.975	Mob. Tel.
455.000 - 455.975	Remote Br.
456.000 - 458.975	P.D., F.D., Ind., Land Tr.
459.000 - 459.975	Domestic Public
460.000 - 460.625	P.D., F.D.
460.650 - 462.175	Bus.
462.000 - 462.450	Taxi

462.550 - 462.725	C.B.
462.750 - 462.975	Bus.
463.000 - 463.175	Med.
463.200 - 464.975	Bus.
465.000 - 467.500	P.D., F.D., Ind., Land Tr.
467.750 - 467.925	Bus.
467.5375 - 467.7375	C.B.
467.7375 - 469.975	Pub. Safety, Ind., Land Tr.

In some large metropolitan areas, 1 or 2 channels of the "TV Band" (470MHz to 512 MHz) are used for communication purposes. Each T.V. station (channels 14 through 20) utilizes 6MHz:

470-476 T.V.	Channel 14
476-482 T.V.	Channel 15
482-488 T.V.	Channel 16
488-494 T.V.	Channel 17
494-500 T.V.	Channel 18
500-506 T.V.	Channel 19
506-512 T.V.	Channel 20

Where these frequencies are assigned for communication purposes, in lieu of a T.V. station, the 6MHz segment is allocated as shown here for channel 14 (470-476MHz).

470.0125 - 470.2875	Domestic Public
470.0124 - 470.2875	Domestic Public (Base, Mob.)
470.3125 - 471.1375	Public Safety
471.1625 - 471.2875	Reserve Pool A
471.3125 - 471.4125	Pwr., Tel. Maint.
471.4375 - 471.6375	Spec. Ind.
471.6625 - 471.7875	Reserve Pool B
471.8125 - 472.3375	Bus.
472.3625 - 472.4375	Taxi
472.4675 - 472.7875	R.R., Motor Carrier, Auto Emer.
472.8125 - 472.987	Pet., For. Prod., Mfg.
473.0125 - 473.2875	Domestic Public
473.3125 - 474.1375	Public Safety
474.1625 - 474.2875	Reserve Pool A
474.3125 - 474.4125	Pwr., Tel. Maint.
474.4375 - 474.6375	Spec. Ind. (Mobile)
474.6625 - 474.7875	Reserve Pool B
474.8125 - 475.3375	Bus.
475.3625 - 475.4375	Taxi
475.4625 - 475.7875	R.R., Motor Carrier, Auto Emer.
475.8125 - 475.9875	Pet., For. Prod., Mfg.

The same allocation pattern is repeated for each of the TV channels 14 thru 20. For example, is channel 17 is assigned for communications in your area, "Taxi" would be 490.3625 to 490.4375 and 493.4375 (corresponding to 472.3625 to 472.4375 and 475.3625 to 475.4375 above). Note that in the example, we added three TV channels (18MHz) to the channel 14 frequencies.

CHANNEL	XMIT FREQUENCY (MHz)		AUTHORIZED TRAFFIC
	SHIP	COAST	
1	156.050	160.650	International Only
2	156.100	160.700	International Only
3	156.150	160.750	International Only
4	156.200	160.800	International Only
5	156.250	160.850	International Only
6	156.300		INTERNATIONAL SAFETY
7	156.350	160.950	International Only
7A	156.350	156.350	Commercial
8	156.400		Commercial
9	156.450	156.450	Commercial, Non-Commercial
10	156.500	156.500	Commercial
11	156.550	156.550	Commercial
12	156.600	156.600	Port Operations, USCG
13	156.650	156.650	Canals, Locks, Pilots
14	156.700	156.700	Port Operations, USCG
15		156.750	Environmental, Hydrographic
16	156.800	156.800	DISTRESS, SAFETY, & CALLING
17	156.850	156.850	Restricted, State Control
18	156.900	161.500	International Only
18A	156.900	156.900	Commercial
19	156.950	161.550	International Only
19A	156.950	156.950	Commercial
20	157.000	161.600	Port Operations
21	157.050	161.650	International Only
21CG	157.050	157.050	Restricted, USCG
22	157.100	161.700	International Only
22CG	157.100	157.100	Restricted, USCG
23	157.150	161.750	International Only
23CG	157.150	157.150	Restricted, USCG
24	157.200	161.800	Public Correspondence
25	157.250	161.850	Public Correspondence
26	157.300	161.900	Public Correspondence
27	157.350	161.950	Public Correspondence
28	157.400	162.000	Public Correspondence
29	157.450	157.450	International Only
30	156.025	160.625	International Only
31	156.075	160.675	International Only
32	156.125	160.725	International Only
33	156.175	160.775	International Only
34	156.225	160.825	International Only
35	156.275	160.875	International Only
35A	156.275	156.275	Port Operations
36	156.325	160.925	International Only
36A	156.325	156.325	Port Operations
37	156.375		Commercial
38	156.425	156.425	Non Commercial
39	156.475	156.475	Non Commercial
40	156.525		Non Commercial
41	156.575	156.575	Non Commercial
42	156.625		Non Commercial
43	156.675	156.675	Port Operations
44	156.725	156.725	Port Operations
45			GUARD CHANNEL, Unuseable
46			GUARD CHANNEL, Unuseable
47			Commercial
48	156.875		International Only
49	156.925	161.525	Non-Commercial
78A	156.925	156.925	International Only
79	156.975	161.575	Commercial
79A	156.975	156.975	International Only
80	157.025	161.625	Commercial
80A	157.025	157.025	International Only
81	157.075	161.675	International Only
82	157.125	161.725	International Only
83	157.175	161.775	International Only
83CG	157.175	157.175	USCG Auxiliary Only
84	157.225	161.825	Public Correspondence
85	157.275	161.875	Public Correspondence
86	157.325	161.925	Public Correspondence
87	157.375	161.975	Public Correspondence
88	157.425	162.025	International Only
89	157.475	157.475	Commercial

AIRCRAFT FREQUENCIES

90 to 128.8	Air Traffic Control, at the field and up to 30 miles from major airports and includes: Approach Control Departure Control Center Tower ATIS Automatic Terminal Information Service Clearance Delivery majority of communications below 125.00)
-------------	---

SPECIFIC FREQUENCIES WITHIN THE 118-135.975 RANGE:

121.5	National Aircraft Emergency
121.6 to 121.9	Ground Control of aircraft at major airports
121.975-122.675	General aviation aeronautical advisory stations and Air Traffic Control. Commonly called Flight Service Station (FSS)
122.0	Weather Advisory
123.6	FSS at airport with a tower
122.7 to 123.05	Unicom-Communications at General Aviation airports
122.90, 122.95	Air to Air Communications
123.1	Search and Rescue
123.175-123.575	Flight test.—manufacturers, etc.
123.3-123.5	Flight schools-instruction
126.2	Military Towers
128.825-132.00	Aeronautical Enroute Frequencies Airlines communication with their companies
132.025-135.975	Air Traffic Control beyond 30 miles of major airport. Usually remote stations.

NOTE: Authorization and channels used may vary with locality. Check with local authorities for verification.