

NAVWEPS 16-30ART13-5  
Formerly AN 08-30ART13-5

## Handbook

### Maintenance Instructions

# AIRCRAFT RADIO EQUIPMENT

AN/ART-13

OSCILLATOR

O-17/ART-13A

PUBLISHED UNDER AUTHORITY OF THE SECRETARY OF THE AIR FORCE  
AND THE CHIEF OF THE BUREAU OF NAVAL WEAPONS

*26 January 1945*

*Revised 15 July 1954*

Reproduction for non-military use of the information or illustrations contained in this publication is not permitted without specific approval of the issuing service (BuAer or AMC). The policy for use of Classified Publications is established for the Air Force in AFR 205-1 and for the Navy in Navy Regulations, Article 1509.

## LIST OF REVISED PAGES ISSUED

INSERT LATEST REVISED PAGES. DESTROY SUPERSEDED PAGES.

NOTE: The portion of the text affected by the current revision is indicated by a vertical line in the outer margins of the page.

Page No.	Date of Latest Revision	Page No.	Date of Latest Revision
1	1 May 1953	5-24A	1 June 1952
ii	1 June 1952	5-25	1 June 1952
iii	1 June 1952	5-27	1 June 1952
* v	15 July 1954	5-28	1 June 1952
* vi	15 July 1954	* 5-46	15 July 1954
vii	1 May 1953	* 5-46A	15 July 1954
* viii	15 July 1954	6-2	1 June 1952
* viiiA	15 July 1954	6-6	1 June 1952
1-OA	1 May 1953	6-6A	1 June 1952
1-1	1 June 1952	* 6-22	15 July 1954
* 1-2	15 July 1954	6-24	1 June 1952
1-3	1 May 1953	6-42	1 June 1952
1-4	1 May 1953	6-42A	1 June 1952
1-6	1 May 1953	6-48A	1 May 1953
* 1-7	15 July 1954	6-48B	1 May 1953
* 1-8	15 July 1954	* 6-50A	15 July 1954
* 1-8A	15 July 1954	* 7-1	15 July 1954
* 1-9	15 July 1954	7-21	1 May 1953
2-0	1 May 1953	* 7-35A	15 July 1954
2-2	1 June 1952	* 7-35B	15 July 1954
* 2-4	15 July 1954	* 7-35C	15 July 1954
2-4A	1 May 1953	* 7-35D	15 July 1954
2-5	1 May 1953	7-42	1 June 1952
* 2-6	15 July 1954	7-42A	1 June 1952
2-8	1 June 1952	7-42B	1 June 1952
* 2-12	15 July 1954	* 7-54	15 July 1954
2-14	1 May 1953	7-55	1 May 1953
3-0	1 June 1952	8-14A, 14B	1 May 1953
3-2	1 June 1952	* 8-16A, 16B	15 July 1954
3-3	1 June 1952	* 8-16C, 16D	15 July 1954
3-4	1 June 1952	8-19, 20	1 May 1953
3-6	1 June 1952	8-24A	1 May 1953
3-6A	1 June 1952	8-26	1 June 1952
3-6B	1 June 1952	8-26A	1 June 1952
* 3-17	15 July 1954	* 8-26B	15 July 1954
4-2	1 May 1953	* 8-26C	15 July 1954
4-4	1 June 1952	8-40	1 May 1952
4-5	1 June 1952	8-42A, 42B	1 June 1952
4-6	1 June 1952	8-50A	1 June 1952
4-10	1 June 1952	* 8-59, 60	15 July 1954
4-11	1 June 1952	* 8-61, 62	15 July 1954
4-12	1 June 1952	* 8-63, 64	15 July 1954
5-3	1 May 1953	Index (1)	1 June 1952
5-4	1 June 1952	Index (2)	1 June 1952
5-14	1 June 1952	Index (3)	1 June 1952
5-19	1 June 1952	Index (4)	1 June 1952
5-20A	1 May 1953	Index (5)	1 May 1953
* 5-21	15 July 1954	Index (6)	1 June 1952
5-24	1 June 1952		

\*The asterisk indicates pages revised, added or deleted by the current revision.

## ADDITIONAL COPIES OF THIS PUBLICATION MAY BE OBTAINED AS FOLLOWS:

BuAer

USAF ACTIVITIES.—In accordance with Technical Order No. 00-5-2.

NAVY ACTIVITIES.—Submit request to nearest supply point listed below, using form NavAer-140; NASD, Philadelphia, Pa.; NAS, Alameda, Calif.; NAS, Jacksonville, Fla.; NAS, Norfolk, Va.; NAS, San Diego, Calif.; NAS, Seattle, Wash.; ASD, NSC, Guam.

For listing of available material and details of distribution see Naval Aeronautics Publications Index NavAer 00-500.

## AN 08-30ART13-5

In order to conform to contract number NXsa-95145, the contract or order number given in the lower left-hand corner of each page of Section VII, TABLE OF REPLACEABLE PARTS, should be deleted and contract or order number NXsa-95145 substituted.

A new Dynamotor Power Unit, Type DY-17/ART-13A, is supplied on contract NXsa-95145.

This addenda contains the following material on Dynamotor Power Unit Type DY-17/ART-13A:

1. Dynamotor resistance measurement data.
2. Dynamotor Power Unit installation drawing.
3. Dynamotor schematic diagram.
4. Dynamotor Power Unit schematic diagram.
5. Dynamotor Power Unit Practical Wiring Diagram.
6. Dynamotor sectional drawing.
7. Manufacturers parts list of all dynamotor parts.
8. Dynamotor exploded view photograph.
9. Table of replaceable parts for the complete power unit (including dynamotor) by symbol designation.

**RESISTANCE MEASUREMENTS  
RUSSELL TYPE 14875 DYNAMOTOR**

- A. Resistance from Red, Green and Red-Black wires to frame.
1. Red = Infinity
  2. Green = Infinity
  3. Red-Black = Infinity with brushes removed.

**Note**

One side of the medium voltage winding is grounded to frame through a metal brush holder so that measuring from the red and black wire to frame with brushes in dynamotor, measures the resistance of the medium voltage winding.

- B. Resistance between adjacent bars on 28 volt winding = .010 ohms.
- C. Resistance between diametrically opposed segments on 28 volt winding = .030 ohms.
- D. Resistance between adjacent commutator bars on 400 volt winding = 3.03 ohms.
- E. Resistance between adjacent commutator bars on .50 volt winding = 6.025 ohms.
- F. Shunt field resistance. Windings in series, measured between white and black wires = 27.2 ohms.
- G. Series field resistance = approx. .002 ohms each.

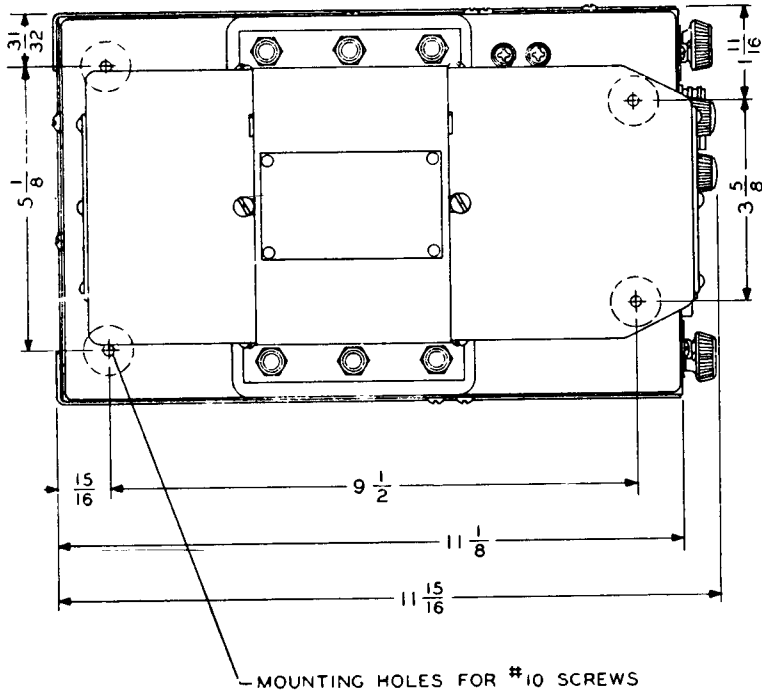

WEIGHT OF UNIT - 28 LBS. MAX

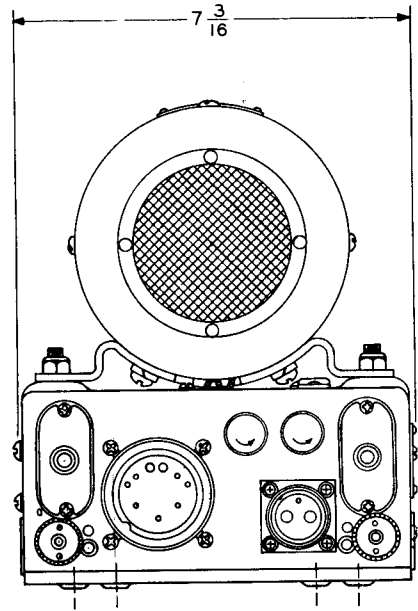
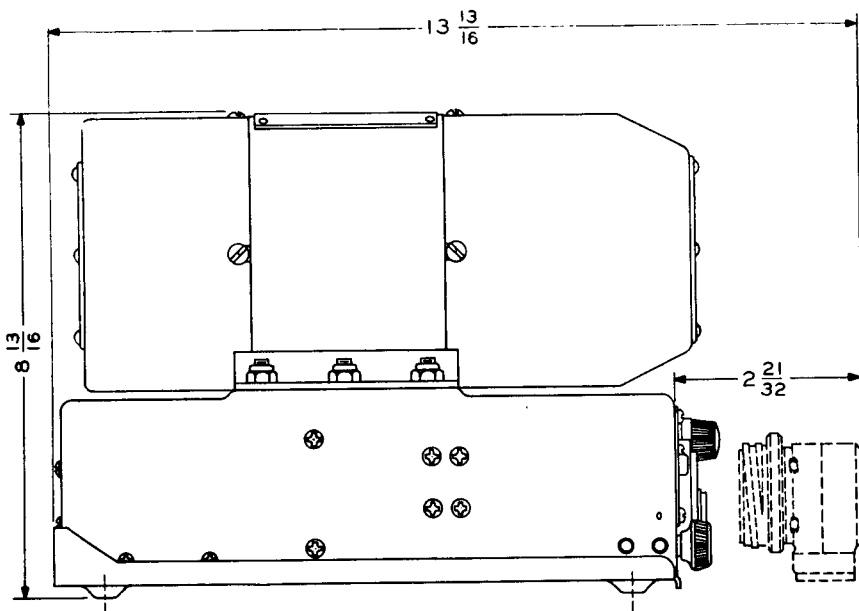

Type DY-17/ART-13A Dynamotor Power Unit Installation Diagram

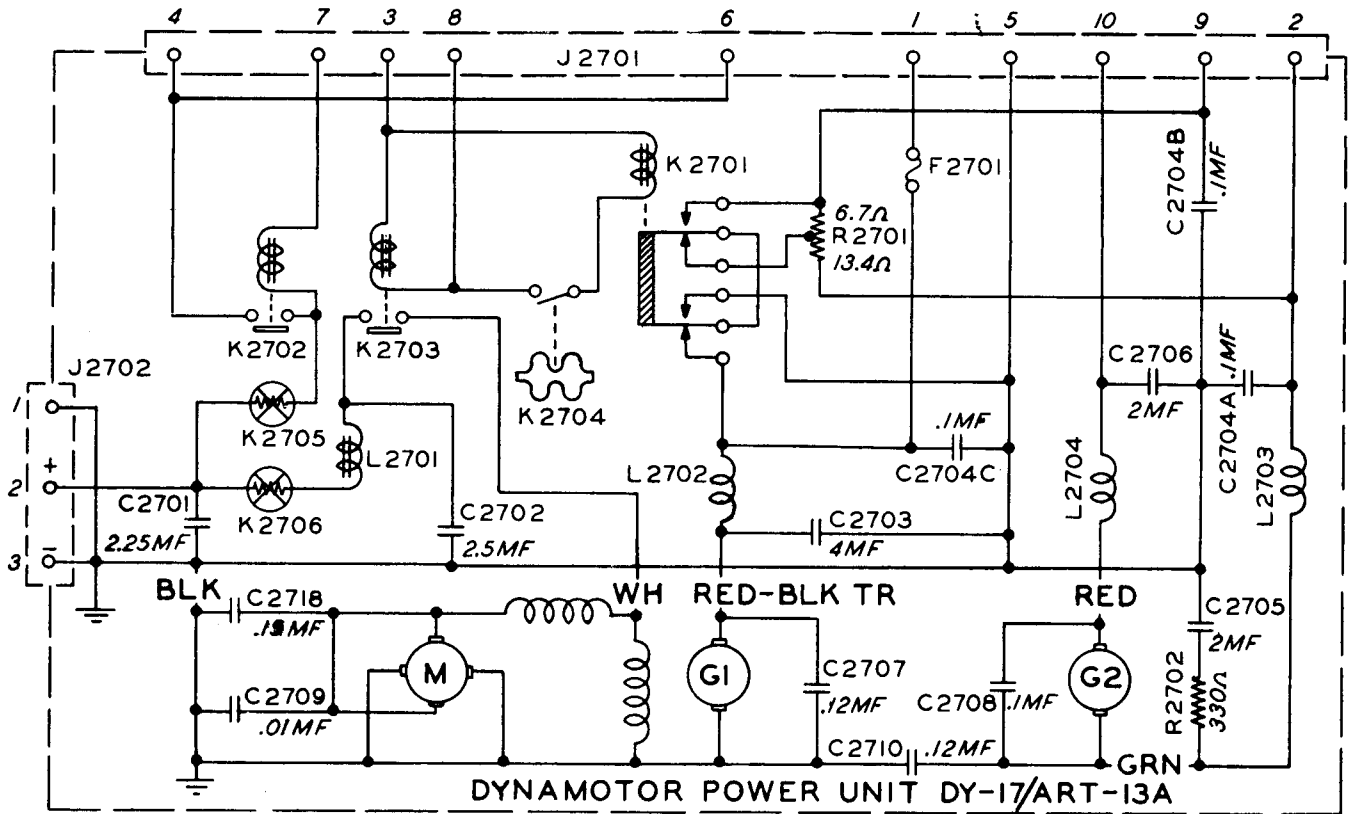

Russell Type 14875 Dynamotor Schematic Diagram

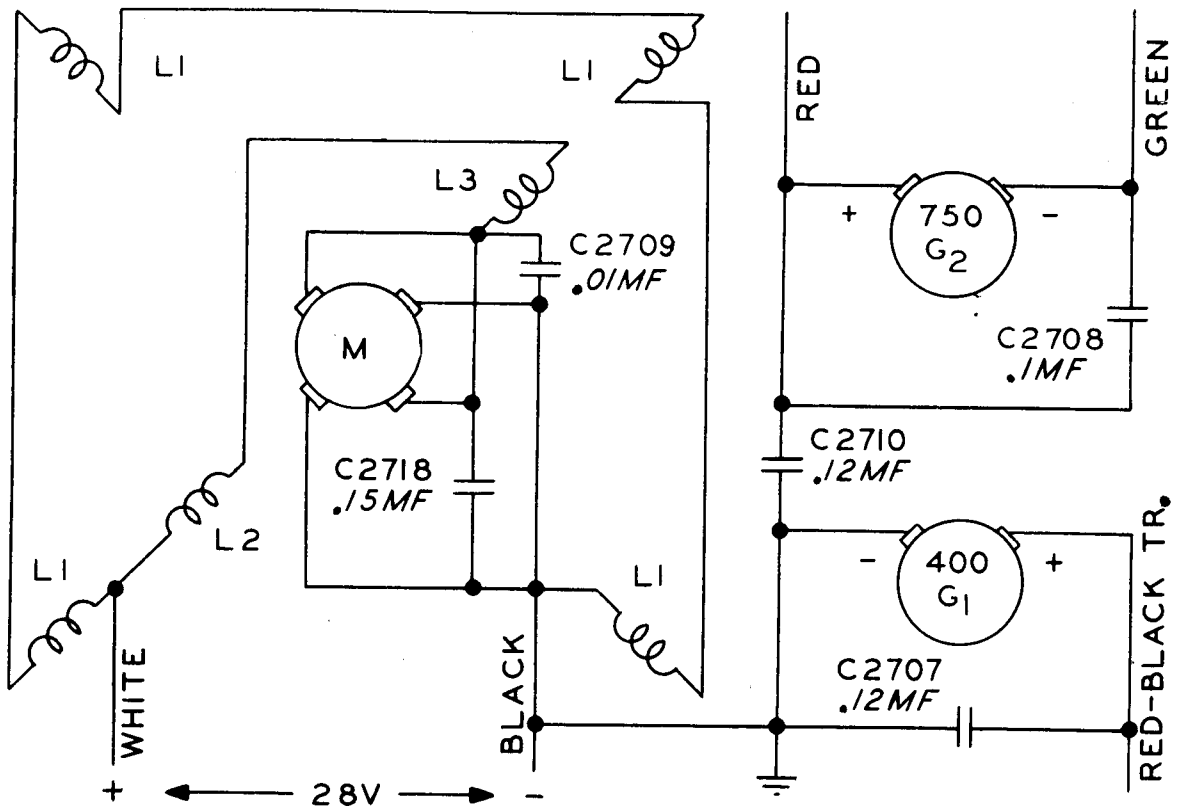

Type DY-17/ART-13A Dynamotor Power Unit Schematic Diagram

AN 08-30ART13-5

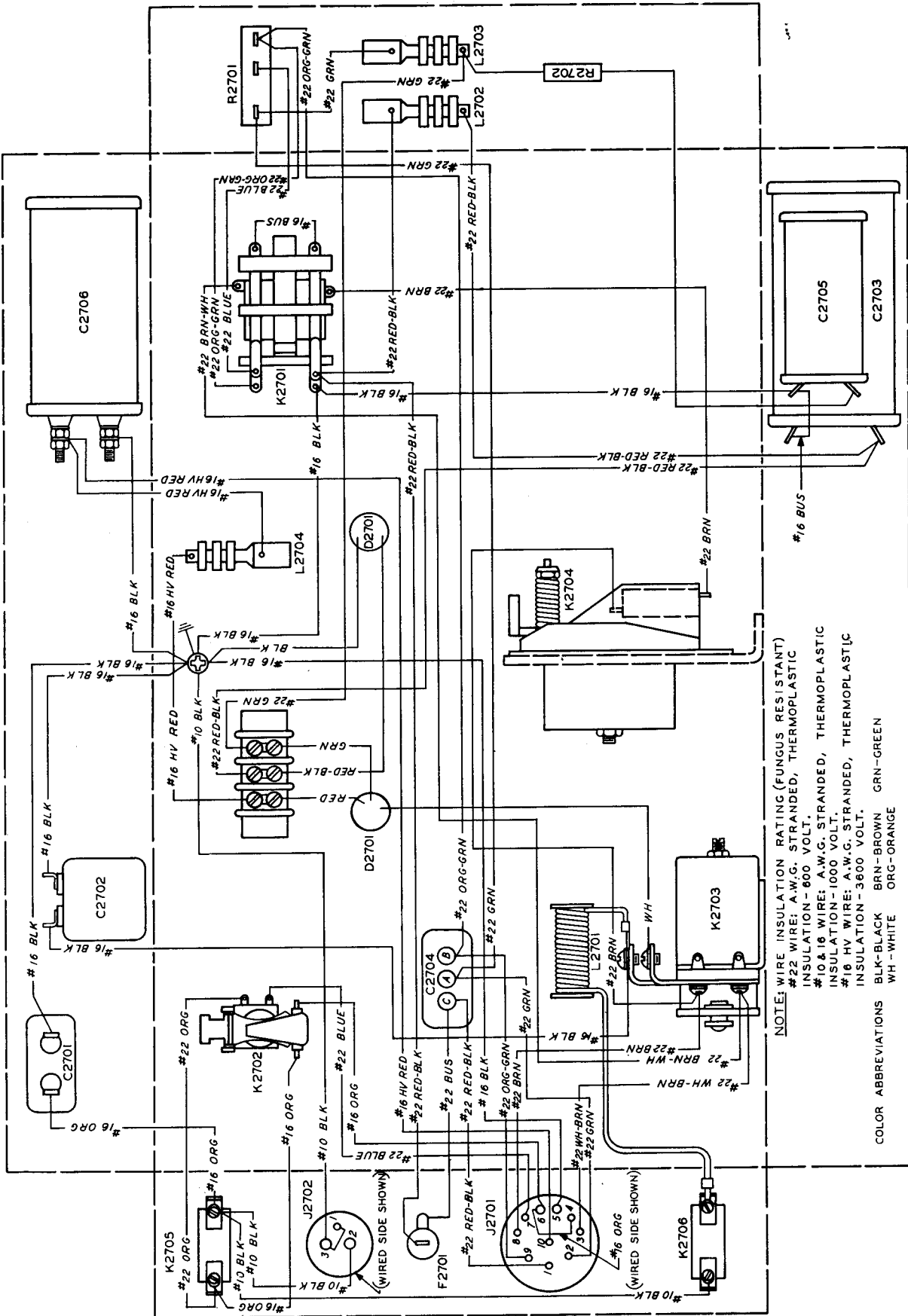

NOTE: WIRE INSULATION RATING (FUNGUS RESISTANT)  
 #22 WIRE: A.W.G. STRANDED, THERMOPLASTIC INSULATION - 600 VOLT.  
 #10 & #16 WIRE: A.W.G. STRANDED, THERMOPLASTIC INSULATION - 1000 VOLT.  
 #16 HV WIRE: A.W.G. STRANDED, THERMOPLASTIC INSULATION - 3600 VOLT.

COLOR ABBREVIATIONS  
 BLK-BLACK BRN-BROWN GRN-GREEN  
 WH-WHITE ORG-ORANGE

Type DY-17/ART-13A Dynamotor Power Unit Practical Wiring Diagram

AN 08-30ART13-5

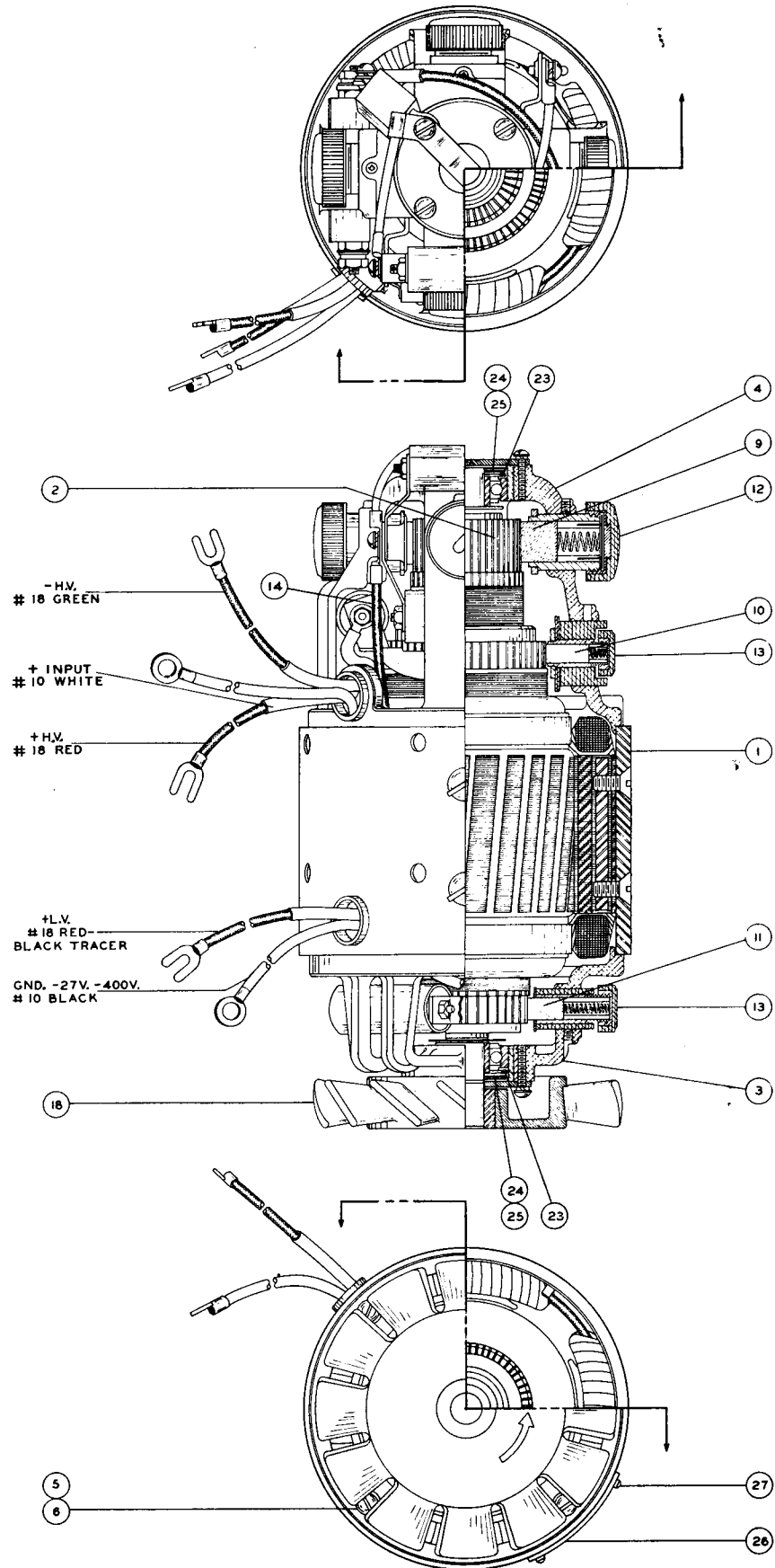

Russell Type 14875 Dynamotor Sectional Drawing

PARTS LIST FOR TYPE DY-17/ART-13A DYNAMOTOR POWER UNIT DYNAMOTOR  
(Russell Type 564000 Part Number 231 0031 00)

<u>Item</u>	<u>Symbol Designation</u>	<u>Quantity</u>	<u>Russell Part Number</u>	<u>Description</u>
1		1	15367	Frame and coil assembly
2		1	15317	Armature and Bearing assembly
3		1	14911	Short Bearing Support assembly
4		1	15368	Long Bearing Support assembly
5		4	14899	Tie Bolts
6		17	6735	Lockwasher, Number 8 split
7		1	13633	Bearing cover
8		4	6958	Mach. Screw 8-32 x $\frac{5}{8}$ Binder Head
9	E-2701A, E-2701B	4	15311	Input Brush
10	E-2701E, E-2701F	2	15313	High Voltage Brush
11	E-2701C, E-2701D	2	15312	Low Voltage Brush
12		4	15308	Brush Holder Cap (Input)
13		4	12813	Brush Holder Cap (Low and High voltage)
14		1	15362	Black Jumper Wire Assembly
15		1	15361	Black Input Lead Assembly
16		1	15366	Red and Black Output Lead Assembly
17		3	6990	Mach. Screw 8-32 x $\frac{5}{16}$ Binder Head Brass
18		1	14890	Fan Assembly
19		1	15304	Short End Shell Assembly
20		1	15305	Long End Shell Assembly
21		6	6993	Mach. Screw 8-32 x $\frac{5}{16}$ Binder Head Steel
22		6	6992	Flat Washer
23		2	15372	Spacer
24		4	15377	.005 Inch Thrust Washer
25		4	15378	.01 Inch Thrust Washer



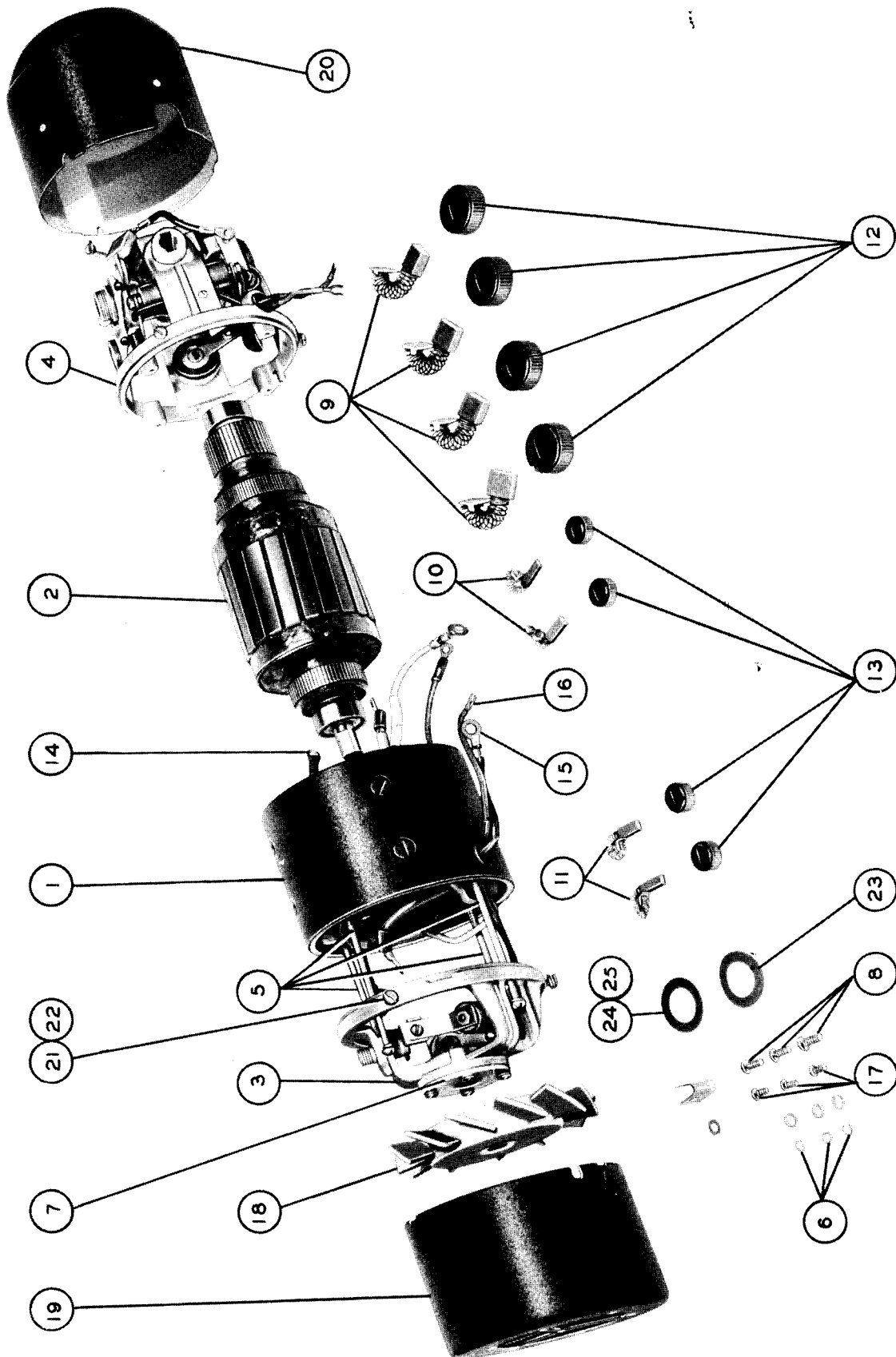

Russell Type G-564000 Dynamotor Exploded View Photograph

TABLE OF REPLACEABLE PARTS  
 DYNAMOTOR POWER UNIT TYPE DY-17/ART-13A  
 MODEL: AN/ART-13 RADIO TRANSMITTING EQUIPMENT MAJOR ASSEMBLY: CONTROL UNIT

Reference Symbol	Army Stock Number Navy Stock Number British Ref. Number	NAME OF PART and DESCRIPTION	FUNCTION	MFR. and DESIG. or AWS TYPE	CONT. or GOVT. DWG. or SPEC. No.
2701-2799		DYNAMOTOR POWER UNIT: Power control unit including Russell dynamotor to furnish all voltages necessary for the operation of the type T-47/ART-13 transmitter		830	520 2560 00
C-2701		CAPACITOR: 2.25 mf 100 v	Supply voltage filter	4210, XDDHRW-1-2.25; 911, GC146; 4250, P2908; 1888, CR2791D-105F3	930 0030 00
C-2702		CAPACITOR: 2.5 mf 100 v	Supply voltage filter	4210, XDHRW-1-2.5; 4250, P2907; 911, HC4106	930 0031 00
C-2703		CAPACITOR: 4 mf ±20% 600 WV	Low voltage filter	911, KG-3040; 1640, A7650; 1888, 67X5	930 8240 00 or 930N8B-M
C-2704	(R) 16 C 11336-75	CAPACITOR: 3-0.1 mf ±20% 600 WV	Alternate	911, KG-3040; 1640, A7650; 1881, 67X5	930 0001 00
C-2704A		CAPACITOR: Section of C-2704	C-2704A, C-2704B, C-2704C	911; 4210; 4250	956 0002 00
C-2704B		CAPACITOR: Section of C-2704	Alternate RF bypass		956 0001 00
C-2704C		CAPACITOR: Section of C-2704	RF bypass		
C-2705	(R) 16 C 11712-310	CAPACITOR: 2 mf ±20% 600 WV	RF bypass		
C-2706	(R) 16 C 11239	CAPACITOR: 2 mf ±20% 1500 v	Alternate	911, KG-3020; 1640, A7649; 1881, 67X2	962 4010 00 930 7824 00 or 930N78B-M
E-2701		Panel Mounting Fuse Holder	High voltage filter Alternate Fuse holder	911; 1881, T-15020 2920, 1212B	930 3522 00 930 0002 00 265 3020 00

**TABLE OF REPLACEABLE PARTS**  
**MODEL: AN/ART-13 RADIO TRANSMITTING EQUIPMENT**      **MAJOR ASSEMBLY: CONTROL UNIT**  
**DYNAMOTOR POWER UNIT TYPE DY-17/ART-13A**

Reference Symbol	Army Stock Number Navy Stock Number British Ref. Number	NAME OF PART and DESCRIPTION	FUNCTION	MFR. and DESIG. or AWS TYPE	CONT. or GOVT. DWG. or SPEC. No.
F-2701		FUSE: Cartridge	Low voltage fuse	2920, 4AB-1091B; 530, 4AB-bc	265 1009 00
J-2701	(R) 17 R 1977-10	RECEPTACLE: 10 terminal wall mounting	Dynamotor supply connector plug receptacle	630, RFK-10-31SL	371 5119 00 or 371N511R
J-2702	(R) 17 R 1965-48	RECEPTACLE: 3 terminal wall mounting	Dynamotor input plug receptacle	630, GK-C3-32S	371 2010 00 or 371N201
K-2701	(R) 16 R 5069-20	RELAY: 2 PDT circuit control	Power change Alternate Alternate	257, R-22B 2050 2050, G-33375	410 0013 00 410 0014 00 410 2000 00 or 410N20
K-2702	(R) 16 R 5685-125	RELAY: 1 pole normally open double break circuit control	Primary power contactor	2050, G-32793	405 2202 00 or 405NE202
K-2703	(R) 16 R 5685-115	RELAY: SP normally open solenoid contactor	Dynamotor input control	2050, G-31199	401 7900 00 or 401N79
K-2704	(R) 17 S 25171	RELAY: SP normally open barometric circuit control switch	Voltage control Alternate	43, 9M-1 1888, CR2927	260 0013 00 260 4570 00 or 260N457
K-2705		RELAY: 10 amp 28 v single circuit	Transmitter power overload		260 0016 00
K-2706		RELAY: 35 amp 28 v single circuit	Dynamotor primary power overload		260 0015 00
L-2701		CHOKE: 5.5μh spiral wound low resistance	Supply voltage filter choke	1640	240 0028 00
L-2702	(R) 16 C 17183	CHOKE: 0.5 mh 0.75 amp 3 section duo-lateral	Low voltage filter choke	1640	240 0002 00
L-2703	(R) 16 C 17184-15	CHOKE: Multi-section duo-lateral wound 1.0 mh, 0.3 amp 10 ohms	Low voltage filter choke	3220, R-300U; 3090	240 5800 00 or 240N58
L-2704		CHOKE: See L-2703			

TABLE OF REPLACEABLE PARTS  
 DYNAMOTOR POWER UNIT TYPE DY-17//ART-13A  
 MAJOR ASSEMBLY: CONTROL UNIT AND DYNAMOTOR

MODEL: AN/ART-13 RADIO TRANSMITTING EQUIPMENT

Reference Symbol	Army Stock Number Navy Stock Number British Ref. Number	NAME OF PART and DESCRIPTION	FUNCTION	MFR. and DESIG. or AWS TYPE	CONT. or GOVT. DWG. or SPEC. No.
R-2701		RESISTOR: 20.1 ohm tapped at 13.4 ohm ±5% 0.5 amp	Voltmeter multiplier	3450	717 4100 00 or 717ND1
R-2702	(R) 16 R 17263-18-3	RESISTOR: 330 ohm ±20% 1 w	Spark suppressor	4230	708 3305 24 or 708N330NB-M 729 0052 00
D-2701		DYNAMOTOR: Input 27 v 32 amp dc Output number 1: 400 v 0.75 amp dc Output number 2: 750 v 0.35 amp dc	Alternate Dynamotor	3970, G-564000	231 0031 00
C-2707		CAPACITOR: 0.12 mf	Low voltage filter	3970, 14909	234 0082 00
C-2708		CAPACITOR: 0.1 mf	High voltage filter	3970, 14908	234 0084 00
C-2709		CAPACITOR: 0.01 mf	Motor brush spark suppressor	3970, 15373	234 0080 00
C-2710		CAPACITOR: 0.12 mf	High voltage filter	3970, 14910	234 0083 00
C-2718		CAPACITOR: 0.15 mf	Motor brush spark suppressor	3970, 15397	234 0081 00
E-2701A		BRUSH: Dynamotor	+ Input brush	3970, 15331SP	234 0117 00
E-2701B		BRUSH: Dynamotor	- Input brush	3970, 15331SP	234 0117 00
E-2701C		BRUSH: Dynamotor	+ LV brush	3970, 15312SP	234 0119 00
E-2701D		BRUSH: Dynamotor	- LV brush	3970, 15312SP	234 0119 00
E-2701E		BRUSH: Dynamotor	+ HV brush	3970, 15313SP	234 0118 00
E-2701F		BRUSH: Dynamotor	- HV brush	3970, 15313SP	234 0118 00

**TABLE OF REPLACEABLE PARTS**  
**DYNAMOTOR POWER UNIT TYPE DY-17//ART-13A**  
**MODEL: AN/ART-13 RADIO TRANSMITTING EQUIPMENT**      **MAJOR ASSEMBLY: DYNAMOTOR**

Reference Symbol	Army Stock Number Navy Stock Number British Ref. Number	NAME OF PART and DESCRIPTION	FUNCTION	MFR. and DESIG. or AWS TYPE	CONT. or GOVT. DWG. or SPEC. No.
<b>MISCELLANEOUS</b>					
		HOLDER: Brush	Dynamotor — input	3970, 15409SP	234 0110 00
		HOLDER: Brush	Dynamotor + input	3970, 15306SP	234 0109 00
		HOLDER: Brush	Dynamotor — LV	3970, 14895SP	234 0111 00
		HOLDER, Brush	Dynamotor + LV	3970, 14897SP	234 0112 00
		HOLDER: Brush	Dynamotor — HV	3970, 14919SP	234 0116 00
		HOLDER: Brush	Dynamotor + HV	3970, 14920SP	234 0113 00
		CAP: Brush holder	Dynamotor ± input	3970, 15308-S	234 0114 00
		CAP: Brush holder	Dynamotor ± LV ± HV	3970, 12813-S	234 0115 00
		BEARING: Roller	Dynamotor armature	3970, X-750B 13401	234 5100 00

**CONTRACT or ORDER No. NXsr-95145**

**PAGE 4 of 4 PAGES**

## LIST OF MANUFACTURERS

Num. Code	Name Address	Num. Code	Name Address
43	Air Communications, Inc. 2233 Grand Avenue Kansas City, Missouri	2050	Guardian Electric Mfg. Co. 1400 West Washington Blvd. Chicago 7, Illinois
257	Annin and Company 85 5th Ave. at 16th St. New York, New York	2920	Littelfuse, Incorporated 4757 Ravenswood Avenue Chicago 40, Illinois
530	Bussmann Mfg. Company Div. of the McGraw Elec. Co. University at Jefferson St. Louis, Missouri	3090	Meissner Manufacturing Co. Mt. Carmel, Illinois
630	Cannon Elec. Devel. Co. 3209 Humboldt Street Los Angeles 31, California	3220	National Company, Inc. 61 Sherman Street Malden 48, Mass.
830	Collins Radio Company 855 35th Street N. E. Cedar Rapids, Iowa	3450	Ohmite Manufacturing Co. 4835 West Flournoy Street Chicago 44, Illinois
911	Cornell-Dubilier Corp. 333 Hamilton Blvd. South Plainfield 6, New Jersey	3970	Russell Electric Company 340 West Huron Street Chicago 10, Illinois
1640	John E. Fast & Company 3123 N. Pulaski Road Chicago 41, Illinois	4210	Sola Electric Company 2525 Clybourn Avenue Chicago 14, Illinois
1881	General Electric Co. 840 S. Canal Street Chicago, Illinois	4230	Speer Resistor Corporation St. Mary's, Pennsylvania
1888	General Electric Co. Electronics Dept. 754 State Street Schenectady 7, New York	4250	Sprague Electric Company North Adams, Mass.

## TABLE OF CONTENTS

Paragraph	Page
<b>SECTION I GENERAL DESCRIPTION</b>	
1. General .....	1-1
2. Types of Emission .....	1-1
3. Audio Input .....	1-2
4. Frequency Range .....	1-2
5. Frequency Change System .....	1-2
6. Power Output .....	1-2
7. Power Source .....	1-3
8. Control .....	1-3
9. Overload Protection .....	1-4
10. Principal Components .....	1-5
a. Equipment Supplied .....	1-5
b. Equipment Required but Not Supplied .....	1-7
c. Additional Equipment Required for Low Frequency Operation in the Range 200 kc to 1500 kc .....	1-7
11. Accessories .....	1-8
12. Interchangeability of Units .....	1-9
<b>SECTION II INSTALLATION AND ADJUSTMENT</b>	
1. Installation .....	2-1
a. Uncrating .....	2-1
b. General .....	2-1
c. Tubes .....	2-1
d. Crystal .....	2-1
e. Operational Check .....	2-1
f. Mounting of Units .....	2-3
(1) Type T-47/ART-13 .....	2-3
(2) Dynamotor Power Unit .....	2-3
(3) Type C-87/ART-13 and C-740/ART-13 Pilot's Control Unit .....	2-4
(4) Antenna Shunt Capacitor .....	2-4
(5) Dummy Low Frequency Oscillator .....	2-4
(6) Loading Coils .....	2-4
g. Fuse .....	2-5
h. Interconnecting Wires .....	2-5
i. Connections .....	2-5
(1) Power Connections .....	2-5
(2) Inter-Unit Connections .....	2-5
(3) Antenna Connections .....	2-6
(4) Optional Auxiliary Connections .....	2-6
j. Explanatory Notes Referring to Installation Drawings, Figure 2-1 and Figure 2-2 .....	2-6
2. Adjustment .....	2-7
a. General .....	2-7
b. Radio Transmitter T-47/ART-13 Adjustment for Operation .....	2-8
(1) CW Operation in the Range 2000 kc to 18,100 kc .....	2-8
(2) Use of Antenna Shunt Capacitors .....	2-11

<u>Paragraph</u>	<u>Page</u>
(3) CW Operation in the Range 200 kc to 1500 kc .....	2-12
(4) Precaution against Operation on a Harmonic of the Desired Frequency .....	2-12
(5) Voice Operation .....	2-13
(6) MCW Operation .....	2-13
(7) Sidetone Amplifier Adjustment .....	2-13
(8) Operation—Remote Control .....	2-14

### SECTION III OPERATION

1. Function of Controls .....	3-0
2. Low Frequency Oscillator Installation .....	3-1
3. Adjustment of Transmitter on Desired Frequency Using Internal Crystal Frequency Calibrator (CFI) .....	3-2
Table 3-1 Type O-16/ART-13 LFO Calibration Data .....	3-4
Table 3-1A Type O-17/ART-13A LFO Calibration Data .....	3-6
Table 3-2 HFO Calibration Data .....	3-6B
4. Tuning Instructions for Low Frequency Operation Below 2000 kc	3-17
5. Tuning Instructions for High Frequency Operation in the Range 2000 kc to 18,100 kc .....	3-17
Table 3-3 Typical Antenna Tuning Data .....	3-20
Table 3-4 Typical Antenna Tuning Data .....	3-24

### SECTION IV THEORY OF OPERATION

1. Power Control Circuits .....	4-1
2. Filament Circuits .....	4-4
3. High Voltage Circuits .....	4-4
4. Emission Selection and Control .....	4-5
5. Audio Circuits .....	4-6
a. Speech Amplifier .....	4-6
b. Modulator .....	4-7
c. Sidetone Amplifier .....	4-8
d. Calibration Oscillator .....	4-9
e. MCW Audio Oscillator .....	4-9
6. Radio-Frequency Circuits .....	4-10
a. Low-Frequency Circuits .....	4-10
b. High-Frequency Oscillator Circuits .....	4-12
c. Multiplier Circuits .....	4-13
d. Power Amplifier and Output Network .....	4-15
7. Autotune System .....	4-16
a. General .....	4-16
b. Mechanical Details .....	4-16
c. Electrical Details .....	4-20
d. Autotune Operation .....	4-23
e. Unit Function .....	4-24

### SECTION V MAINTENANCE

1. General .....	5-1
2. Preflight Operational Check .....	5-1
3. Routine Check .....	5-1
4. Servicing .....	5-3
a. General .....	5-3
b. Vacuum Tube Replacement .....	5-3
c. Vacuum Tube Failure Symptoms .....	5-4



<u>Paragraph</u>	<u>Page</u>
d. Trouble Shooting .....	5-5
(1) General .....	5-5
(2) Pilot's Control Unit .....	5-21
(3) Dynamotor .....	5-21
(4) Power Control Unit .....	5-21
(5) Antenna Loading Coils .....	5-21
(6) Transmitter Unit .....	5-21
5. Radio-Frequency Circuit Alignment .....	5-24
a. Type O-16/ART-13 LF Oscillator Alignment .....	5-24
b. Type O-17/ART-13A LF Oscillator Alignment .....	5-24A
c. High-Frequency Oscillator Alignment Using CFI .....	5-25
d. High-Frequency Oscillator Alignment Using External Frequency Standard .....	5-27
e. Frequency Multiplier Alignment .....	5-28
6. MCW-CFI Adjustment .....	5-30
a. CFI Alignment Using Transmitter Sidetone Circuits .....	5-31
b. MCW Adjustment .....	5-32
c. CFI Alignment Using Vacuum Tube Voltmeters .....	5-32
7. Precision Calibration of MCW-CFI Unit Crystal Oscillator .....	5-33
8. Maintenance of Autotune Mechanism .....	5-33
a. Lubrication .....	5-33
b. Synchronization Check .....	5-35
c. Synchronization .....	5-36
d. Autotune Positioning Mechanism .....	5-37
e. Autotune Limit Switch .....	5-38
9. Replacement of Autotune Parts .....	5-39
10. The Adjustment and the Replacement of Parts of Commercial Assemblies .....	5-43
<b>SECTION VI SUPPLEMENTARY DATA</b>	
1. Power Input Requirements .....	6-1
2. Typical Audio-Frequency Data .....	6-1
a. Overall Audio-Frequency Response .....	6-1
b. Audio Input .....	6-1
c. Noise Level .....	6-1
d. Audio Distortion .....	6-1
e. Sidetone Distortion .....	6-1
f. Sidetone Output .....	6-1
Table 6-1 MCW-CFI Unit Output Level .....	6-2
3. Resistance Measurements on Rotating Machines .....	6-9
a. Autotune Motor .....	6-9
b. High Voltage Dynamotor .....	6-10
4. Applicable Color Codes .....	6-11
a. Radio Manufacturers Association Codes .....	6-11
(1) Molded Case Mica Dielectric Capacitor Color Codes .....	6-11
(2) Ceramic Capacitor Color Code .....	6-12
(3) Resistor Color Code .....	6-13
b. American Standards Association Codes .....	6-13
(1) Fixed Paper Dielectric Capacitors .....	6-13
(2) Fixed Mica-Dielectric Capacitors .....	6-14
(3) Fixed Ceramic-Dielectric Capacitors .....	6-15
(4) Fixed Molded Paper-Dielectric Capacitors .....	6-17
(5) Fixed Composition Resistors .....	6-18
c. Hookup Wire Code .....	6-19

<u>Paragraph</u>	<u>Page</u>
Table 6-2 AN/ART-13 Cable Wire Code.....	6-20
<i>d.</i> Code for Bus-Bar.....	6-22
5. General Specifications of Equipment.....	6-22
<i>a.</i> Frequency Range.....	6-22
<i>b.</i> Frequency Bands.....	6-22
<i>c.</i> Frequency Stability.....	6-22
<i>d.</i> Antenna Requirements.....	6-23
<i>e.</i> Power Output.....	6-23
<i>f.</i> Input Impedance.....	6-23
<i>g.</i> Power Source.....	6-23
<i>h.</i> Power Input.....	6-23
<i>i.</i> Dynamotors.....	6-23
<i>j.</i> Modulation.....	6-24
6. Tube Complement.....	6-24
7. Characteristics of Vacuum Tubes used in the AN/ART-13 Equipment.....	6-24
6V6, 6V6-GT/G.....	6-25
12SJ7-12SJ7-GT.....	6-25
811.....	6-26
1625.....	6-27
837.....	6-29
813.....	6-31
12SL7-GT.....	6-33
12SA7, 12SA7-GT/G.....	6-34
8. United States-British Glossary of Terms Used in this Handbook.....	6-35
9. Photographs.....	6-35
<b>SECTION VII TABLE OF REPLACEABLE PARTS</b>	
1. Introduction.....	7-1
Table of Replaceable Parts.....	7-2
2. List of Manufacturers.....	7-54

#### SECTION VIII DRAWINGS

#### INDEX

## LIST OF ILLUSTRATIONS

Figure	Title	Page
1-1.	Complete AN/ART-13 Equipment .....	1-0
1-1A.	Type C-740/ART-13 Pilot's Control Unit .....	1-0A
1-2.	Type T-47/ART-13 Transmitter .....	1-1
1-3.	Type T-47/ART-13 Transmitter—Top Open .....	1-1
1-4.	Type T-47/ART-13 Transmitter—Units Removed .....	1-1
1-5.	Type C-87/ART-13 Pilot's Control Unit .....	1-3
1-5A.	Type C-740/ART-13 Pilot's Control Unit .....	1-4
1-6.	Type DY-12/ART-13 Dynamotor Power Unit .....	1-4
1-7.	Type CR-2-B/U (200 kc) Crystal Unit .....	1-8
1-8.	Type CU-24/ART-13 Antenna Shunt Capacitor .....	1-8
1-9.	Type O-16/ART-13 Low Frequency Oscillator .....	1-8
1-9A.	Type O-17/ART-13A Low Frequency Oscillator .....	1-8
1-10.	Type CU-25/ART-13 Antenna Loading Coil .....	1-8A
1-11.	Type CU-26/ART-13 Antenna Loading Coil .....	1-8A
1-12.	Type CU-32/ART-13A Antenna Loading Coil .....	1-8A
2-1.	Model AN/ART-13 High Frequency Installation Diagram ..	2-0
2-2.	Model AN/ART-13 Installation Diagram Including Special Low Frequency Units .....	2-0
2-3.	Tube Placement Diagram .....	2-2
2-4.	Type T-47/ART-13 Transmitter Mounting Plate MT-283/ART-13 and Mounting Base MT-284/ART-13 ..	2-3
2-5.	Type DY-12/ART-13 Dynamotor Power Unit and Mounting Base MT-164/ART-13 .....	2-3
2-6.	Type C-87/ART-13 Pilot's Control Unit Mounting Base MT-163/ART-13 .....	2-4
2-7.	Type CU-26/ART-13 Antenna Loading Coil Mounting Base MT-162/ART-13 .....	2-5
2-8.	Microphone Switch and Sidetone Amplifier Gain Control ..	2-13
3-1.	Type T-47/ART-13 Transmitter Controls .....	3-1
3-2.	High Frequency Tuning Control .....	3-2
4-1.	Power Control Circuit .....	4-2
4-2.	Filament Circuits .....	4-4
4-3.	High Voltage Circuits .....	4-5
4-4.	Emission Selection and Control Circuits .....	4-5
4-5.	Speech Amplifier Circuit .....	4-6
4-6.	Audio Circuits Block Diagram .....	4-7
4-7.	Modulator Circuit .....	4-7
4-8.	Sidetone Amplifier Circuit .....	4-8
4-9.	CFI Circuit .....	4-8
4-10.	MCW Audio Oscillator Circuit .....	4-10
4-11.	MCW-CFI Circuits Block Diagram .....	4-10
4-12.	Low Frequency RF Circuits in Installations Using LFO O-16/ART-13 .....	4-11
4-12A.	Low Frequency RF Circuits in Installations Using LFO O-17/ART-13A .....	4-11
4-13.	Low Frequency RF Circuits Block Diagram .....	4-11
4-14.	High Frequency Oscillator Circuit .....	4-12
4-15.	High Frequency Multiplier Circuit .....	4-14
4-16.	High Frequency Power Amplifier Circuit .....	4-14
4-17.	High Frequency RF Circuits Block Diagram .....	4-15
4-18.	Autotune System—Mechanical Details .....	4-17
4-19.	Electrical Autotune Operation Sequence .....	4-21

Figure	Title	Page
5-1.	Typical Operating Voltage and Current Measurement Chart	5-10
5-2.	Typical Resistance Measurement Chart	5-13
5-2A.	Resistance Measurement Chart for C-740/ART-13	5-20A
5-3.	Type NX-128/ART-13 Dummy Low Frequency Oscillator Unit	5-22
5-4.	Type O-16/ART-13 Low Frequency Oscillator	5-24
5-4A.	Type O-17/ART-13A Low Frequency Oscillator	5-24A
5-5.	Low Frequency Oscillator Unit Adjustment	5-24A
5-6.	High Frequency Oscillator	5-26
5-7.	High Frequency Oscillator Adjustment	5-27
5-8.	Frequency Multiplier	5-29
5-9.	Frequency Multiplier Adjustment	5-30
5-10.	MCW-CFI Unit Adjustment	5-31
5-11.	Autotune System Lubrication Chart	5-34
5-12.	Autotune Singleturn Unit—Left Side	5-36
5-13.	Autotune Singleturn Unit—Right Side	5-36
5-14.	Autotune Multiturn Unit—Left Side	5-37
5-15.	Autotune Multiturn Unit—Right Side	5-37
5-16.	Autotune Casting	5-41
5-17.	Keying Relay (K102) Contact Arrangement	5-44
5-18.	Keying Relay (K102) Adjustment	5-45
5-18A.	Relay (K2501)	5-46A
5-19.	410 0008 00 Keying Relay (K102)	5-48
5-20.	410 1700 00 CW Relay (K103)	5-50
5-21.	410 1600 00 "Voice" Relay (K104)	5-52
5-22.	410 0010 00 Choke Shorting Relay (K105)	5-54
5-23.	401 7900 00 Dynamotor Input Relay (K2101)	5-55
5-24.	405 2202 00 Primary Power Contactor (K2102)	5-56
5-25.	410 2000 00 Power Change Relay (K2105)	5-58
5-26.	274 1400 00 Telegraph Key (S603)	5-59
5-27.	Emerson Type NY-818C-A Motor Parts	5-61
5-28.	Emerson Type NY-818C-A Motor	5-62
5-29.	Ohio Type NY-818C-B Motor	5-63
5-30.	Ohio Type NY-818C-B Motor Parts	5-64
5-31.	Fractional Type NY-818C-C Motor	5-65
5-32.	Fractional Type NY-818C-C Motor Parts	5-67
5-33.	Russell Type 502 D3 COA Dynamotor Parts	5-70
5-34.	Russell Type 502 D3 COA Dynamotor	5-71
5-35.	Wincharger Type 51S1 Dynamotor	5-72
5-36.	Wincharger Type 51S1 Dynamotor Parts	5-75
5-37.	Fractional Type D-100 Dynamotor Parts	5-77
5-38.	Fractional Type D-100 Dynamotor	5-78
6-1.	Type O-16/ART-13 LFO Tuning Chart	6-4
6-1A.	Type O-17/ART-13A LFO Tuning Chart	6-6
6-2.	High Frequency Tuning Chart	6-6A
6-3.	Emerson Type NY-818C-A Motor Schematic	6-9
6-4.	Ohio Type NY-818C-B Motor Schematic	6-9
6-5.	Fractional Type NY-818C-C Motor Schematic	6-9
6-6.	Russell Type 502 D3 COA Dynamotor Schematic	6-10
6-7.	Wincharger Type 51S1 Dynamotor Schematic	6-10
6-8.	Fractional Type D-100 Dynamotor Schematic	6-11
6-9.	RMA Capacitor Color Code Example—Four Dot	6-12
6-10.	RMA Capacitor Color Code Example—Six Dot	6-12
6-11.	RMA Resistor Code Example	6-13

Figure	Title	Page
6-12.	ASA Fixed Mica-Dielectric Capacitor Color Code .....	6-14
6-13.	ASA Fixed Ceramic-Dielectric Capacitor Color Code .....	6-15
6-14.	ASA Fixed Molded Paper Dielectric Capacitor Color Code .....	6-17
6-15.	ASA Fixed Composition Resistor Color Code .....	6-18
6-16.	ASA Alternate Color Coding for Radial-Lead Resistor .....	6-19
6-17.	Overall Frequency Response Curve at 90% Modulation .....	6-24
6-18.	Type T-47/ART-13 Transmitter Unit—Front View Open .....	6-36
6-19.	Type T-47/ART-13 Transmitter Unit—Top View Open .....	6-36
6-20.	Type T-47/ART-13 Transmitter Unit—Bottom View Open .....	6-37
6-21.	High Frequency Oscillator—Side View Open .....	6-38
6-22.	Frequency Multiplier—Side View Open .....	6-39
6-23.	Fire Wall Assembly—Top View .....	6-40
6-24.	Fire Wall Assembly—Bottom View .....	6-40
6-25.	Type NX-128/ART-13 Dummy Low Frequency Oscillator Unit—Side View .....	6-41
6-26.	Type O-16/ART-13 Low Frequency Oscillator Unit—Top View Open .....	6-41
6-26A.	Type O-17/ART-13A Low Frequency Oscillator Unit—Top View Open .....	6-42
6-27.	Type O-16/ART-13 Low Frequency Oscillator Unit—Bottom View Open .....	6-42
6-27A.	Type O-17/ART-13A Low Frequency Oscillator Unit—Bottom View Open .....	6-42A
6-28.	MCW-CFI Unit—Top View .....	6-43
6-29.	MCW-CFI Unit—Bottom View Open .....	6-43
6-30.	Audio Amplifier Unit—Top View .....	6-44
6-31.	Audio Amplifier Unit—Bottom View .....	6-44
6-32.	Multi-Element Switch—Right Side View .....	6-45
6-33.	Multi-Element Switch—Left Side View .....	6-46
6-34.	Type DY-12/ART-13 Dynamotor Power Unit—Top View .....	6-47
6-35.	Type DY-12/ART-13 Dynamotor Power Unit—Bottom View Open .....	6-47
6-36.	Type C-87/ART-13 Pilot's Control Unit—Front View .....	6-48
6-37.	Type C-87/ART-13 Pilot's Control Unit—Rear View Open .....	6-48
6-37A.	Type C-740/ART-13 Pilot's Control Unit—Front View .....	6-48A
6-37B.	Type C-740/ART-13 Pilot's Control Unit—Rear View .....	6-48B
6-38.	Type CU-25/ART-13 Antenna Loading Coil Unit—Front View .....	6-49
6-39.	Type CU-25/ART-13 Antenna Loading Coil Unit—Open View .....	6-49
6-40.	Type CU-26/ART-13 Antenna Loading Coil Unit—Front View .....	6-50
6-41.	Type CU-26/ART-13 Antenna Loading Coil Unit—Inside View .....	6-50
6-42.	Type CU-24/ART-13 Antenna Shunt Capacitor—Top View .....	6-51
6-43.	Autotune Singleturn Unit—Left Side View .....	6-52
6-44.	Autotune Singleturn Unit—Right Side View .....	6-52
6-45.	Autotune Multiturn Unit—Left Side View .....	6-53
6-46.	Autotune Multiturn Unit—Right Side View .....	6-53
6-47.	Autotune Casting—Inside View .....	6-54
8-1.	Type T-47/ART-13 Transmitter Installation Diagram .....	8-1, 2
8-2.	Type MT-283/ART-13 Transmitter Mounting Plate .....	8-3, 4

Figure	Title	Page
8-3.	Type MT-284/ART-13 Transmitter Shockmounting Base .....	8-5, 6
8-4.	Type DY-11/ART-13 Dynamotor Power Unit Installation Diagram .....	8-7, 8
8-5.	Type DY-12/ART-13 Dynamotor Power Unit Installation Diagram .....	8-9, 10
8-6.	Type DY /ART-13 Dynamotor Power Unit Installation Diagram .....	8-11, 12
8-7.	Type C-87/ART-13 Pilot's Control Unit Installation Diagram .....	8-13, 14
8-7A.	Type C-740/ART-13 Pilot's Control Unit Installation Diagram .....	8-14A, 14B
8-8.	Type CU-25/ART-13 Antenna Loading Coil Installation Diagram .....	8-15, 16
8-8A.	Mounting Base MT-198/ART-13A .....	8-16A, B
8-8B.	Type CU-32/ART-13A Antenna Loading Coil, Outline .....	8-16C, D
8-9.	Type CU-26/ART-13 Antenna Loading Coil Installation Diagram .....	8-17, 18
8-10.	Type CU-24/ART-13 Antenna Shunt Capacitor Installation Diagram .....	8-17, 18
8-11.	Type AN/ART-13 Equipment Complete Schematic ..	8-19, 20
8-12.	Type T-47/ART-13 Transmitter Schematic .....	8-21, 22
8-13.	Type DY-11/ART-13 Dynamotor Power Unit Schematic .....	8-23
8-14.	Type DY-12/ART-13 Dynamotor Power Unit Schematic .....	8-23
8-15.	Type DY- /ART-13 Dynamotor Power Unit Schematic .....	8-24
8-16.	Type C-87/ART-13 Pilot's Control Unit Schematic .....	8-24
8-16A.	Type C-740/ART-13 Pilot's Control Unit Schematic .....	8-24A
8-17.	Type CU-24/ART-13 Antenna Shunt Capacitor Unit Schematic .....	8-24
8-18.	Type O-16/ART-13 Low Frequency Oscillator Unit Schematic .....	8-25
8-18A.	Type O-17/ART-13A Low Frequency Oscillator Unit Schematic .....	8-26
8-19.	Type CU-25/ART-13 Antenna Loading Coil Unit Schematic .....	8-26A
8-20.	Type CU-26/ART-13 Antenna Loading Coil Unit Schematic .....	8-26A
8-20A.	Type CU-32/ART-13A Antenna Loading Coil, Wiring Diagram .....	8-26B
8-20B.	Type CU-32/ART-13A Antenna Loading Coil, Schematic Diagram .....	8-26C
8-21.	Type T-47/ART-13 Transmitter Practical Wiring Diagram—All Units Removed .....	8-27, 28
8-22.	High Frequency Oscillator Practical Wiring Diagram	8-29
8-23.	Multiplier Practical Wiring Diagram .....	8-31, 32
8-24.	Audio Unit Practical Wiring Diagram .....	8-33, 34
8-25.	MCW-CFI Unit Practical Wiring Diagram .....	8-35, 36

Figure	Title	Page
8-26.	Type DY-11/ART-13, Type DY-12/ART-13 or Type DY- /ART-13 Dynamotor Power Unit Practical Wiring Diagram .....	8-37, 38
8-27.	Type C-87/ART-13 Pilot's Control Unit Practical Wiring Diagram .....	8-39
8-27A.	Type C-740/ART-13 Pilot's Control Unit Practical Wiring Diagram .....	8-40
8-28.	Type O-16/ART-13 Low Frequency Oscillator Practical Wiring Diagram .....	8-41, 42
8-28A.	Type O-17/ART-13A Low Frequency Oscillator Practical Wiring Diagram .....	8-42A, 42B
8-29.	High Frequency Oscillator Grid Inductor L101 .....	8-43
8-30.	First Multiplier Plate Inductor L105 .....	8-44
8-31.	Second Multiplier Plate Inductor L106 .....	8-45
8-32.	Power Amplifier Plate Feed Choke L108 .....	8-46
8-33.	Output Network Static Drain Choke L110 .....	8-46
8-34.	Power Amplifier Plate Inductor-Rotor for L112 ....	8-47
8-35.	Power Amplifier Plate Inductor-Stator for L112 ....	8-48
8-36.	Antenna Loading Inductor L113 .....	8-49
8-37.	Power Amplifier Tank Padding Inductor L114 .....	8-50
8-38.	Low Frequency Oscillator Grid Inductor L401 .....	8-51
8-38A.	Low Frequency Oscillator Grid Inductor 2602* ....	8-50A
8-39.	Type CU-25/ART-13 Antenna Loading Inductor Rotor for L702 .....	8-52
8-40.	Type CU-26/ART-13 Antenna Loading Inductor Rotor for L802 .....	8-52
8-41.	Type CU-25/ART-13 Antenna Loading Inductor Stator for L702 .....	8-53, 54
8-42.	Type CU-25/ART-13 Antenna Loading Inductor L703 .....	8-55, 56
8-43.	Type CU-26/ART-13 Antenna Loading Inductor Stator for L802 .....	8-57, 58
8-43A.	Type CU-32/ART-13A Antenna Loading Coil, Variometer Assembly (L2501) .....	8-59, 60
8-43B.	Type CU-32/ART-13A Antenna Loading Coil, Rotor for L2501 .....	8-61, 62
8-43C.	Type CU-32/ART-13A Antenna Loading Coil, Coil R.F. (L2502) .....	8-63, 64

## FAILURE REPORTS

### FOR U.S. ARMY AIR FORCE PERSONNEL

In the event of malfunctioning, unsatisfactory design, or unsatisfactory installation of any of the component units of this equipment, or if the material contained in this book is considered inadequate or erroneous, an Unsatisfactory Report, AAF Form No. 54, or a report in similar form, shall be submitted in accordance with the provisions of Army Air Force Regulation No. 15-54 listing:

1. Station and organization.
2. Nameplate data (Type number or complete nomenclature if nameplate is not attached to the equipment).
3. Date and nature of failure.
4. Airplane model and serial number.
5. Remedy used or proposed to prevent recurrence.
6. Handbook errors or inadequacies, if applicable.

### FOR U.S. NAVY PERSONNEL

Report of failure of any part of this equipment during its guaranteed life shall be made on N. Aer. 4112, "Report of Unsatisfactory or Defective Material," or a report in similar form, and forwarded in accordance with the latest instructions of the Bureau of Aeronautics. In addition to other distribution required, one copy shall be furnished to the inspector of Naval Material (Chicago, Illinois) and the Bureau of Ships. Such reports of failure shall include:

1. Reporting activity.
2. Nameplate data.
3. Date placed in service.
4. Part which failed.
5. Nature and cause of failure.
6. Replacement needed (yes—no).
7. Remedy used or proposed to prevent recurrence.

### FOR BRITISH PERSONNEL

Form 1022 procedure shall be used when reporting failure of radio equipment.

## DESTRUCTION OF ABANDONED MATERIAL IN THE COMBAT ZONE

In case it should become necessary to prevent the capture of this equipment and when ordered to do so, **DESTROY IT SO THAT NO PART OF IT CAN BE SALVAGED, RECOGNIZED OR USED BY THE ENEMY. BURN ALL PAPERS AND BOOKS.**

### Means:-

1. Explosives, when provided.
2. Hammers, axes, sledges, machetes, or whatever heavy object is readily available.
3. Burning by means of incendiaries such as gasoline, oil, paper, or wood.
4. Grenades and shots from available arms.
5. Burying all debris or disposing of it in streams or other bodies of water, where possible and when time permits.

### Procedure:-

1. Obliterate all identifying marks. Destroy nameplates and circuit labels.
2. Demolish all panels, castings, switch- and instrument-boards.
3. Destroy all controls, switches, relays, connections, and meters.
4. Rip out all wiring and cut interconnections of electrical equipment. Smash gas, oil and water-cooling systems in gas-engine generators, etc.
5. Smash every electrical or mechanical part, whether rotating, moving, or fixed.
6. Break up all operating instruments such as keys, phones, microphones, etc.
7. Destroy all classes of carrying cases, straps, containers, etc.
8. Bury or scatter all debris.

**DESTROY EVERYTHING!**



## WARNING

OPERATION OF THIS EQUIPMENT INVOLVES THE USE OF HIGH VOLTAGES WHICH ARE DANGEROUS TO LIFE. OPERATING PERSONNEL MUST AT ALL TIMES OBSERVE ALL SAFETY REGULATIONS. DO NOT CHANGE TUBES OR MAKE ADJUSTMENTS INSIDE EQUIPMENT WITH HIGH VOLTAGE SUPPLY ON. ALWAYS SHUT DOWN THE DYNAMOTOR OR OTHER ASSOCIATED POWER EQUIPMENT AND OPEN MAIN SWITCH IN POWER SUPPLY CIRCUIT. UNDER CERTAIN CONDITIONS DANGEROUS POTENTIALS MAY EXIST IN CIRCUITS WITH POWER CONTROLS IN THE OFF POSITION DUE TO CHARGES RETAINED BY CAPACITORS, ETC. TO AVOID CASUALTIES ALWAYS DISCHARGE AND GROUND CIRCUITS PRIOR TO TOUCHING THEM.

\* \* \*

Since the use of high voltages which are dangerous to human life is necessary to the successful operation of the radio transmitting equipment covered by these instructions, certain reasonable precautionary measures must be carefully observed by the operating personnel during the adjustment and operation of the equipment.

While every practicable safety precaution has been incorporated in this equip-

ment, the following rules must be strictly observed:

### KEEP AWAY FROM LIVE CIRCUITS

Under no circumstances should any person be permitted to reach within the transmitter cabinet with power supply line switches to the equipment closed; or to approach or handle any portion of the equipment which is supplied with power, or to connect any apparatus external to the enclosure to circuits within the equipment; or to apply voltages to the equipment for testing purposes while the cabinet is open. Whenever feasible in testing circuits, check for continuity and resistance rather than directly checking voltage at various points.

### DON'T SERVICE OR ADJUST ALONE

Under no circumstances should any person reach within the cabinet for the purpose of servicing or adjusting the equipment without the immediate presence or assistance of another person capable of rendering aid.

THE ATTENTION OF OFFICERS AND OPERATING PERSONNEL IS DIRECTED TO BUREAU OF SHIPS MANUAL OF ENGINEERING INSTRUCTIONS, CHAPTER 31 (MIMEOGRAPHED FORM) OR SUBSEQUENT REVISIONS THEREOF ON THE SUBJECT OF "RADIO—SAFETY PRECAUTIONS TO BE OBSERVED".

## CONTRACTUAL GUARANTEE

The equipment including all parts and spare parts, except vacuum tubes, batteries, rubber and material normally consumed in operation, is guaranteed for a period of one year from the date of delivery of the equipment to and acceptance by the Government with the understanding that all such items found to be defective as to material, workmanship, or manufacture, will be repaired, or replaced, f.o.b. any point within the continental limits of the United States designated by the Government, without delay and at no expense to the Government; provided that such guarantee will not obligate the Contractor to make repair or replacement of any such defective items unless the defect appears within the aforementioned period and the Contractor is notified thereof in writing within a reasonable time and the defect is not the result of normal expected shelf life deterioration.

To the extent the equipment, including all parts and spare parts, as defined above, is of the Contractor's design or is of a design selected by the Contractor, it is also guaranteed, subject to the foregoing conditions, against defects in design with the understanding that if ten per cent (10%) or more of any such said item, but not less than two of any such item, of the total quantity comprising such item furnished under the contract,

are found to be defective as to design, such item will be conclusively presumed to be of defective design and subject to one hundred per cent (100%) correction or replacement by a suitably redesigned item.

All such defective items will be subject to ultimate return to the Contractor. In view of the fact that normal activities of the Naval Service may result in the use of equipment in such remote portions of the world or under such conditions as to preclude the return of the defective items for repair or replacement without jeopardizing the integrity of Naval communications, the exigencies of the Service, therefore, may necessitate expeditious repair of such items in order to prevent extended interruption of communications. In such cases the return of the defective items for examination by the Contractor prior to repair or replacement will not be mandatory. The report of a responsible authority, including details of the conditions surrounding the failure, will be acceptable as a basis for affecting expeditious adjustment under the provisions of this contractual guarantee.

The above one-year period will not include any portion of time the equipment fails to perform satisfactorily due to any such defects, and any items repaired or replaced by the Contractor will be guaranteed anew under this provision.

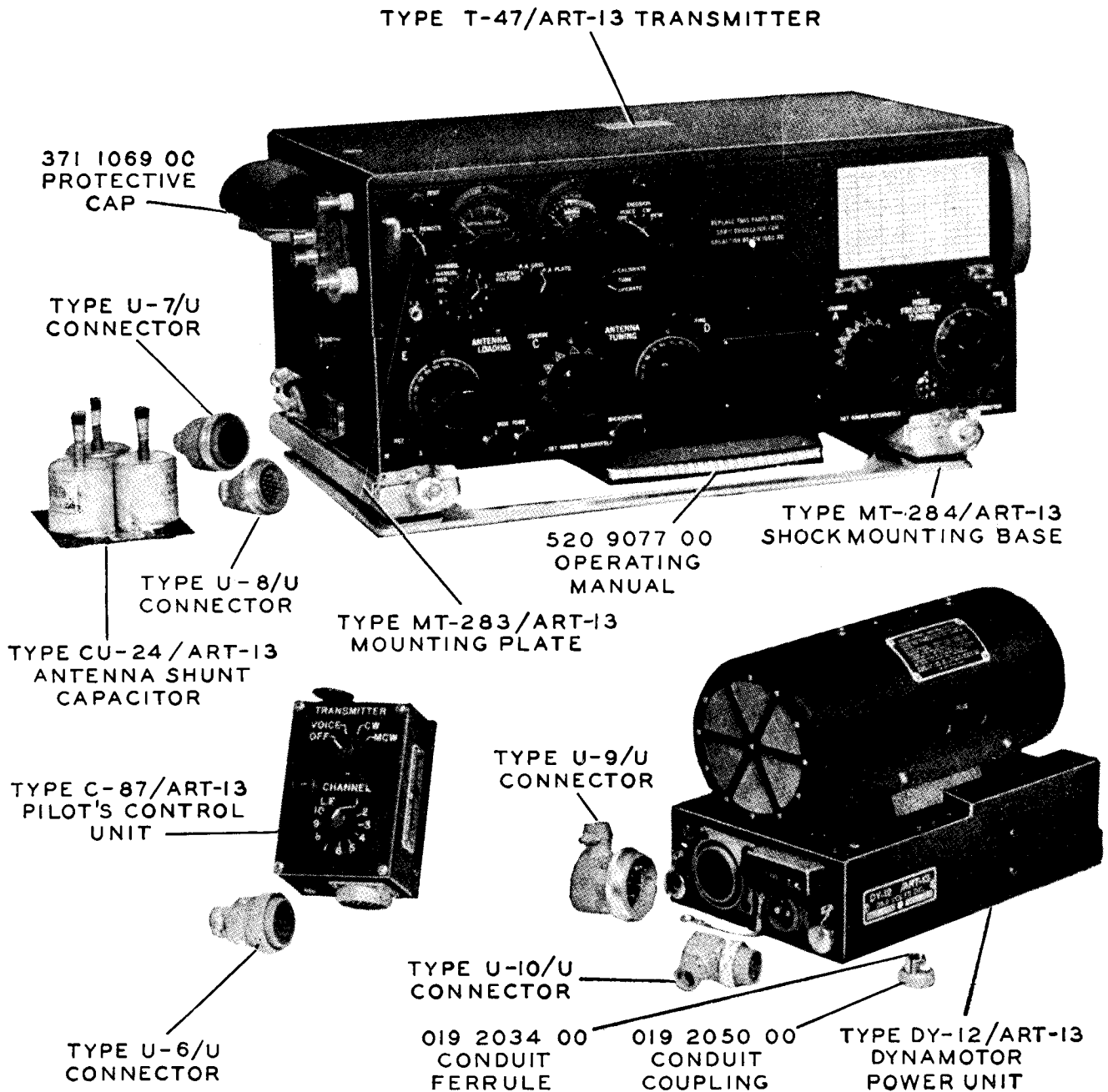

Figure 1-1. Complete AN/ART-13 Equipment



Figure 1-1A. Type C-740/ART-13 Pilot's Control Unit

SECTION I  
GENERAL DESCRIPTION

## 1. GENERAL.

a. The Model AN/ART-13 Series Aircraft Radio Transmitting Equipment has been designed for installation in aircraft. Care has been taken in the design to insure mechanical construction that will withstand the vibration and shock incident to normal service. All materials used in the construction of the equipment are, as far as practicable, resistant to corrosion resulting from the chemical action of a moist saline atmosphere.



Figure 1-2. Type T-47/ART-13 Transmitter

b. Sub-assembly type of construction has been used extensively in the Type T-47/ART-13 Transmitter (figure 1-2.). This type of construction facilitates the removal of component parts without major disassembly of the unit. The MCW-CFI, the Audio Amplifier, and the Dummy Low Frequency Oscillator Units are connected by multi-

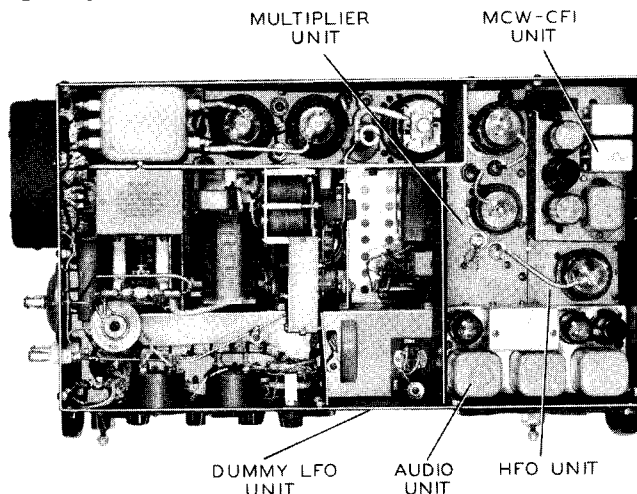

Figure 1-3. Type T-47/ART-13 Transmitter —  
Top Open

terminal plugs to facilitate removal for servicing (figure 1-3. and figure 1-4.). An effort has been made to make all components that may require replacement easily accessible.

c. The Autotune System has been incorporated in the Model AN/ART-13 Series Equipment to permit rapid frequency change. This system is an electrically controlled means of mechanically repositioning adjustable elements such as switches, variable inductors and variable capacitors. The accuracy of repositioning is of a very high order and is not seriously affected by wear, humidity or temperature changes. No tools are necessary for the changing of the position of any of the controls. Eleven Autotune positions are available, permitting transmission on any one of eleven preset frequencies. One of these positions may be used for operation below 1500kc or 600kc provided a Low Frequency Oscillator, Type O-16/ART-13 (figure 1-9.) or Type O-17/ART-13A (figure 1-9A.) is installed in the transmitter unit and the correct external loading coils are used.

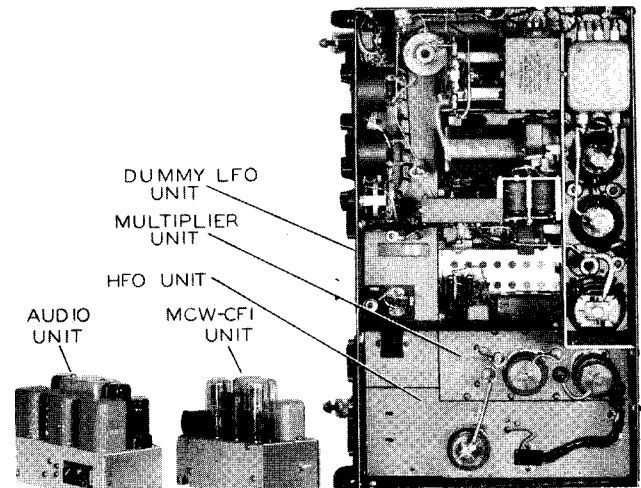

Figure 1-4. Type T-47/ART-13 Transmitter —  
Units Removed

## 2. TYPES OF EMISSION.

CW, MCW, and VOICE modulated types of emission are available with the AN/ART-13 equipment. The audio system is capable of modulating the carrier (100 watts nominal) at least 90% for MCW or VOICE emission. Keying speeds up to 30 words per minute may be used when operating

with CW and MCW emission without objectionable chirp or distortion of the length of the keyed characters.

**3. AUDIO INPUT.**

Either of two types of microphone may be used with this equipment. An input circuit has been incorporated in the equipment to permit the use of either a carbon or dynamic type of microphone. When the microphone switch, S201, (*figure 2-8, page 2-13*) is in DYNAMIC position, an audio input of 16 millivolts to the MICROPHONE jack, J102, is required for 90% modulation. When the microphone switch is in the CARBON position 1.52 volt audio input at J102 is required for 90% modulation. The audio frequency response is uniform within 3 db between 300 cps and 4000 cps. The audio frequency distortion is less than 15% rms at 1000 cps and with 90% modulation of the carrier (100 watts nominal).

**4. FREQUENCY RANGE.**

**a. HIGH FREQUENCY RANGE.**

The high frequency range extends from 2000 kc to 18,100 kc.

**b. LOW FREQUENCY RANGE.**

(1) For installations equipped with a Type O-16/ART-13 Low Frequency Oscillator, output may be obtained on either 200 kc or 500 kc to 1500 kc depending on the loading coil used. The Type CU-25/ART-13 Antenna Loading Coil (*figure 1-10*) and the Type CU-32/ART-13A (*figure 1-12*) are designed for operation in the range 200 kc to 600 kc with a trailing wire antenna 200 feet in length. The Type CU-26/ART-13 Antenna Loading Coil (*figure 1-11*) is designed for operation in the frequency range 500 kc to 1100 kc with a trailing wire antenna 200 feet in length, and in a frequency range 1100 kc to 1500 kc with a trailing wire antenna 150 feet in length. No modification of the transmitter adjustment is necessary to change from one loading coil to the other, except selection of frequency is necessary.

(2) For installations equipped with a Type O-17/ART-13A Low Frequency Oscillator 200 kc

to 600 kc output may be obtained with the Type CU-25/ART-13 or CU-32/ART-13A Antenna Loading Coil.

c. A fixed antenna of the usual aircraft type, from 17 feet to 60 feet in length, may be used when operating the transmitter in the high frequency band. However, this type of antenna may not have sufficient capacity to match the impedance of the transmitter output network in the frequency range 2000 kc to 3000 kc. Therefore, the Type CU-24/ART-13 Antenna Shunt Capacitor Unit has been supplied to permit antenna matching when operating within the above frequency range.

**5. FREQUENCY CHANGE SYSTEM.**

a. The Autotune frequency change system employed in the AN/ART-13 equipment is an electrically controlled mechanical system of positioning the transmitter tuning elements. The positioning elements are driven by a single motor. The system will operate to change the frequency of transmission in less than 25 seconds at normal room temperature and with a battery voltage of 28 volts. A detailed description of both the mechanical and electrical portions of the Autotune is given in SECTION IV of this Handbook of Maintenance Instructions.

b. Manual frequency change and tuning adjustments may be made without disturbing the Autotune stop-ring adjustments if the CHANNEL selector switch is placed in the MANUAL position and the Autotune system allowed to operate.

**6. POWER OUTPUT.**

a. The power delivered to the antenna varies with frequency and antenna characteristics.

b. Two power levels are available in the equipment. The power is automatically reduced to half the full power by a pressure operated relay when an altitude of approximately 25,000 feet is reached.

c. The following table shows the power output obtainable at frequencies from 200 kc to 18,100 kc and the values of resistance and reactance of the antenna used while making the measurements:

Frequency	Antenna Reactance	Antenna Resistance	Power Output	See Note
200 kc	—j2000 ohms	10.0 ohms	5.5 watts	(1)
300 kc	—j1150 ohms	9.5 ohms	14.0 watts	(1)
400 kc	—j 750 ohms	7.0 ohms	18.0 watts	(1)
500 kc	—j 580 ohms	7.0 ohms	24.0 watts	(1)
600 kc	—j 480 ohms	7.0 ohms	28.0 watts	(1)
500 kc	—j 600 ohms	8.0 ohms	18.0 watts	(2)
600 kc	—j 480 ohms	8.0 ohms	24.0 watts	(2)
700 kc	—j 380 ohms	8.0 ohms	27.0 watts	(2)
800 kc	—j 300 ohms	10.0 ohms	45.0 watts	(2)

Frequency	Antenna Reactance	Antenna Resistance	Output Power	Note See
1000 kc	—j 210 ohms	18.0 ohms	75.0 watts	(2)
1300 kc	—j 122 ohms	12.0 ohms	80.0 watts	(2)
1500 kc	—j 106 ohms	12.0 ohms	65.0 watts	(2)
2000 kc	—j 500 ohms	2.1 ohms	31.0 watts	(3)
3000 kc	—j 200 ohms	3.1 ohms	60.0 watts	(3)
4000 kc	0 ohms	6.1 ohms	80.0 watts	(3)
5500 kc	+j 380 ohms	25.0 ohms	90.0 watts	(3)
7000 kc	0 ohms	3500.0 ohms	90.0 watts	(3)
9000 kc	—j 350 ohms	50.0 ohms	90.0 watts	(3)
11500 kc	0 ohms	50.0 ohms	90.0 watts	(3)
13500 kc	+j 350 ohms	100.0 ohms	90.0 watts	(3)
15500 kc	0 ohms	1500.0 ohms	75.0 watts	(3)
18100 kc	—j 350 ohms	200.0 ohms	65.0 watts	(3)

**Note**

(1) Measurements were made using the Type CU-25/ART-13 Antenna Loading Coil.

(2) Measurements were made using the Type CU-26/ART-13 Antenna Loading Coil.

(3) Measurements were made while operating into a fixed antenna without a loading coil.

*d.* The above measurements were made with normal 28 volt battery voltage and full voltage (1150 v.) applied to the plate of the power amplifier tube.

*e.* The transmitter will operate without "flashover" and with full power output up to altitudes of approximately 25,000 feet above sea level. A pressure operated relay (K2106) operates at altitudes of approximately 25,000 feet above sea level causing the high voltage to be reduced to 750 volts. With the high voltage reduced to 750 volts, approximately one-half the above output will be obtained and the transmitter will operate without "flashover" up to an altitude of 40,000 feet above sea level.

**7. POWER SOURCE.**

*a.* The AN/ART-13 Equipment is designed to operate from a 28 volt direct current power source. Voltages as low as 24 volts dc may be used, with resulting reduced output and increased time of Autotune operation.

*b.* Typical power input requirements with a supply voltage of 28 volts dc are tabulated below:

Emission	Full Power	Half Power
A1—CW	770 watts	658 watts
A2—MCW	855 watts	700 watts
A3—VOICE (No Mod.)	800 watts	672 watts
A3—VOICE (Full Mod.)	896 watts	700 watts

**8. CONTROL.**

*a.* The channel upon which transmission is desired and the type of emission may be selected and controlled from either the Type T-47/ART-13 Transmitter panel, the Type C-87/ART-13 Pilot's Control Unit (figure 1-5.), the Type C-740/ART-13 Pilot's Control Unit (figure 1-5A.) or other remote control units.

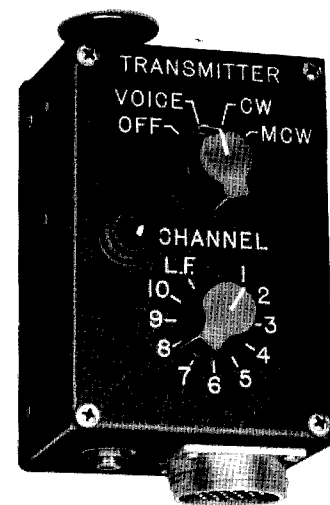

Figure 1-5. Type C-87/ART-13 Pilot's Control Unit

b. The Type T-47/ART-13 Transmitter control consists of a TEST switch, a LOCAL-REMOTE switch, a CHANNEL selector switch, a metered circuit selector switch, a power level switch, an EMISSION selector switch, a DYNAMIC or CARBON microphone selecting switch, HIGH FREQUENCY oscillator TUNING, ANTENNA TUNING—COARSE, ANTENNA TUNING—FINE, and ANTENNA LOADING controls, KEY, MICROPHONE and Throttle Switch jacks for control of emission, jacks for SIDETONE monitoring and a sidetone OUTPUT control.

c. The controls on the Type C-87/ART-13 Pilot's Control Unit consist of a CHANNEL selector switch, an emission selector switch, a microphone jack and a telegraph key. The Type C-740/ART-13 Pilot's Control Unit has a CHANNEL selector switch and an emission selector switch but has neither a microphone jack nor a telegraph key.

**9. OVERLOAD PROTECTION.**

The 400 volt output circuit of the dynamotor supply is protected from short circuit by a 250 volt 1 amp fuse F2101. Two thermal operated relays in the 28 volt supply leads protect the primary power circuits. These relays are located in the Dynamotor Power Unit (figure 1-6.) and are of the single circuit "Reset" type.

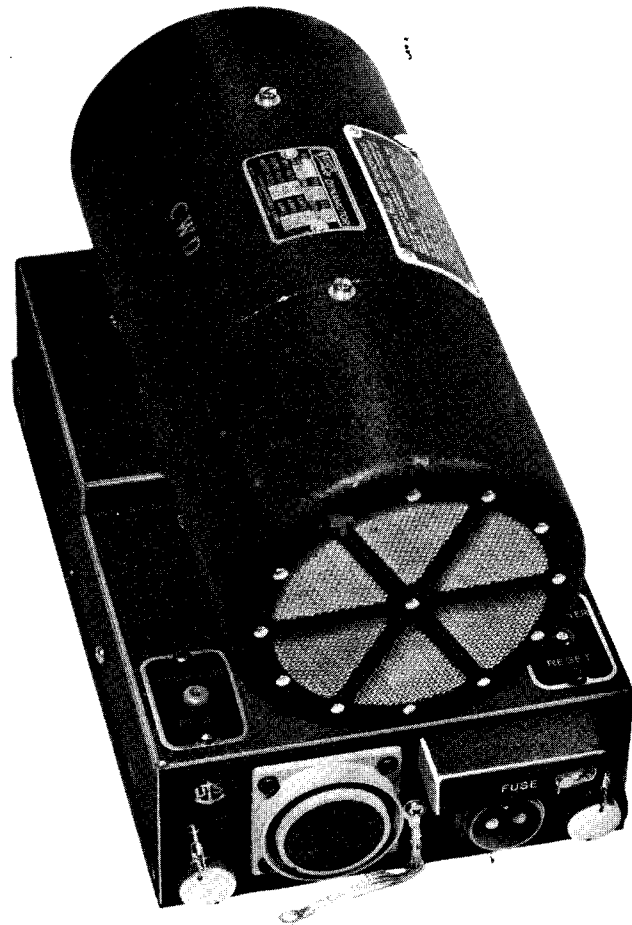

Figure 1-6. Type DY-12/ART-13 Dynamotor Power Unit



Figure 1-5A. Type C-740/ART-13 Pilot's Control Unit



## 10. PRINCIPAL COMPONENTS.

## a. EQUIPMENT SUPPLIED.

Quantity Per Equipment	Name of Unit	Army-Navy Type Designation	Overall Dimensions in Inches			Weight in Pounds	Numerical Series of Reference Symbols
			Length	Width	Height		
1	Aircraft Radio Transmitter including: Audio Unit MCW-CFI Unit Calibration Oscillator Crystal Unit Dummy LFO Unit	T-47/ART-13	23-9/16	15-15/32	11-11/32	67	101-199
			8 1/8	3-5/8	5-1/4	4	201-299
			6	3-1/2	5	2.5	2201-2299
		CR-2-B/U	1-1/2	1-1/16	7/16	.03	2201-2299
	Dummy LFO Unit	NX-128/ART-13	8-13 16	5-13/32	5-1/4	.58	401-499
	Protective Cap of Load Coil Connector J107					.02	
1	**Transmitter Mounting Plate	MT-283/ART-13	20-3/4	13-5/64	1-1/2	1.16	
1	Shock Mounting Base	MT-284/ART-13	20-33/64	15-15/32	2-1/2	1.88	
Alternate	*Dynamotor Power Unit (Russell) including: Dynamotor Power Unit Base	DY-11/ART-13	12-3/16	7-1/8	8-1/2	30	2601-2699
		MT-164/ART-13	11-5/32	7-1/16	1-1/4	1.13	
1	*Dynamotor Power Unit (Wincharger) including: Dynamotor Power Unit Base	DY-12/ART-13	12-3/16	7-1/8	8-1/2	30	2101-2199...
		MT-164/ART-13	11-5/32	7-1/16	1-1/4	1.13	
Alternate	*Dynamotor Power Unit (Fractional) including: Dynamotor Power Unit Base	MT-164/ART-13	12-3/16	7-1/8	8-1/2	30	2701-2799
			11-5/32	7-1/16	1-1/4	1.13	

\* One Dynamotor Power Unit only is supplied.

\*\* Considered a part of T-47/ART-13.

EQUIPMENT SUPPLIED. (Continued)

Quantity Per Equipment	Name of Unit	Army-Navy Type Designation	Overall Dimensions In Inches			Weight in Pounds	Numerical Series of Ref. Symbols
			Length	Width	Height		
1	Pilot's Control Unit	C-87/ART-13	6-3/16	3-1/2	3-1/4	1.4	601-699
	Pilot's Control Unit including: Pilot's Control Unit Base	C-740/ART-13	2-1/4	5-3/4	3	1.0	
	Antenna Shunt Capacitor	MT-163/ART-13	5-5/16	3-11/16	3/16	.13	
1	Straight Connector	CU-24/ART-13	5	4-1/8	3-7/8	1.68	1101-1199
1	90 Degree Connector	U-7/U				.25	
1	Straight Connector	U-9/U				.31	
1	Straight Connector	U-8/U				.19	
1	Straight Connector	U-6/U				.25	
1	90 Degree Connector	U-10/U				.31	
1	Conduit Ferrule					.25	
1	Conduit Coupling Nut					.09	

**b. EQUIPMENT REQUIRED BUT NOT SUPPLIED.**

<u>Quantity Per Equipment</u>	<u>Name of Unit</u>	<u>Army-Navy Type Designation</u>	<u>Required Characteristics</u>
1	Microphone		Carbon of 40 ohms Internal Resistance or Dynamic of 200 ohms Internal Resistance for RED coded circuit per Navy Specifications RE 8944A.
1	Microphone Cord		3 Conductor, Shielded.
1	Microphone Cord Plug		3 Circuit, Tip 13/64" Diam and 1-3/16" long.
1	Telegraph Key		Any Type.
1	Telegraph Key Cord		2 Conductor.
1	Telegraph Key Cord Plug		2 Circuit, Tip 1/4" Diam and 1-3/16" long.
1	Headphone		600 ohm Impedance.
1	Headphone Cord Plug		2 Circuit, Tip 1/4" Diam and 1-5/32" long.
1	Throttle Switch		
1	Throttle Switch Cord		2 Conductor.
1	Throttle Switch Cord Plug		2 Circuit, Tip 1/4" Diam and 1-5/32" long.
1	Interphone Connectors		
1	Microphone Cord		3 Conductor, Shielded.
1	Microphone Cord Plug		3 Circuit, Tip 13/64" Diam and 1-3/16" long.
1	Headphone Cord Plug		2 Circuit, Tip 1/4" Diam and 1-5/32" long.
1	Connecting Wire		

**c. ADDITIONAL EQUIPMENT REQUIRED FOR LOW FREQUENCY  
OPERATION IN THE RANGE 200 KC to 1500 KC.**

<u>Quantity Per Equipment</u>	<u>Name of Unit</u>	<u>Army-Navy Type Designation</u>	<u>Required Characteristics</u>
1	Low Frequency Oscillator	O-16/ART-13	Frequency Range 200 kc to 1500 kc. Physically interchangeable with the Type NX-128/ART-13 Dummy Low Frequency Oscillator.
1	Low Frequency Oscillator	O-17/ART-13A	Frequency Range 200 kc to 600 kc. Physically interchangeable with Type NX-128/ART-13 Dummy Low Frequency Oscillator.
1	Antenna Loading Coil	CU-25/ART-13	Frequency Range 200 kc to 600 kc.
1	Antenna Loading Coil including:	CU-32/ART-13A	Frequency Range 200 kc to 600 kc.
1	Antenna Loading Coil Mounting Base	MT-198/ART-13A	

Quantity Per Equipment	Name of Unit	Army-Navy Type Designation	Required Characteristics
1	Antenna Loading Coil including:	CU-26/ART-13	Frequency Range 500 kc to 1500 kc.
1	Antenna Loading Coil Mounting Base	MT-162/ART-13	

**11. ACCESSORIES.**

a. The Type CU-24/ART-13 Antenna Shunt Capacitor (figure 1-8.) is supplied to permit operation in the frequency range 2000 kc to 3000 kc using the conventional type of short, fixed, aircraft antenna.

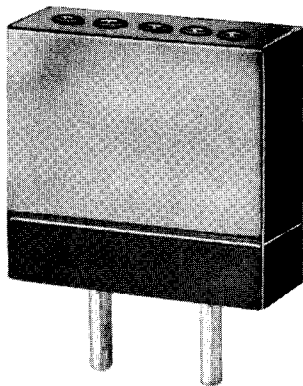

Figure 1-7. Type CR-2-B/U (200kc) Crystal Unit

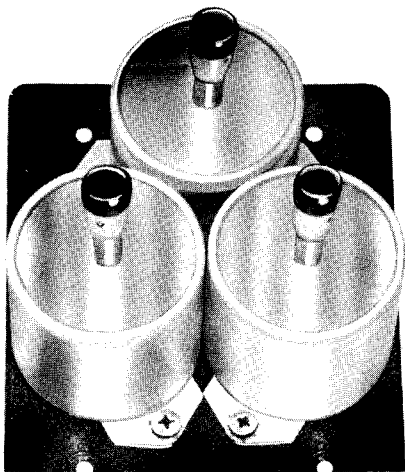

Figure 1-8. Type CU-24/ART-13 Antenna Shunt Capacitor

b. The Antenna Loading Coil is available in three models, the Type CU-25/ART-13, Type CU-32/ART-13A and the Type CU-26/ART-13. For low frequency operation in the frequency range 200 kc to 600 kc, Type CU-25/ART-13 Antenna Loading Coil (figure 1-10) and Type CU-32/ART-13A (figure 1-12) are used.

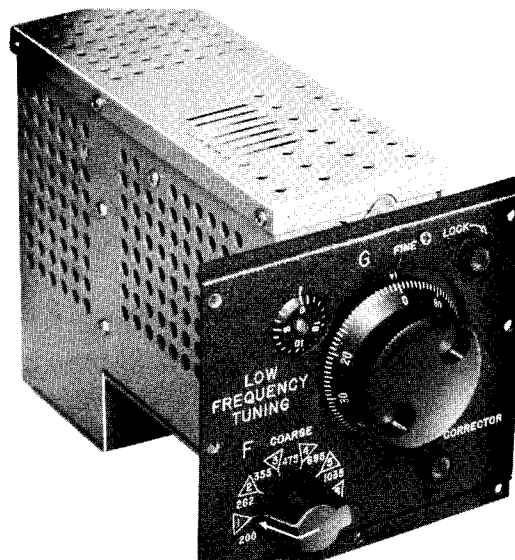

Figure 1-9. Type O-16/ART-13 Low Frequency Oscillator

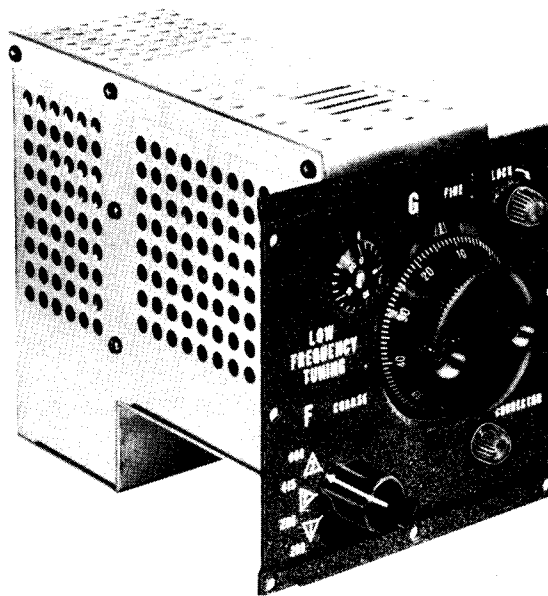

Figure 1-9A. Type O-17/ART-13A Low Frequency Oscillator

b. For operation in the frequency range 500 kc to 1500 kc, the Type CU-26/ART-13 Antenna Loading Coil (figure 1-11.) is used.

c. The Type CR-2-B/U (200 kc) Crystal Unit (figure 1-7.) is mounted in a two prong holder for convenience in mounting in the crystal oscillator calibration unit.

d. Power, control and unit-interconnecting plug connectors are furnished with the fittings necessary to complete the installation.

e. Complete sets of Phillips and Bristo wrenches are fastened in brackets provided on the left-hand side of the transmitter.

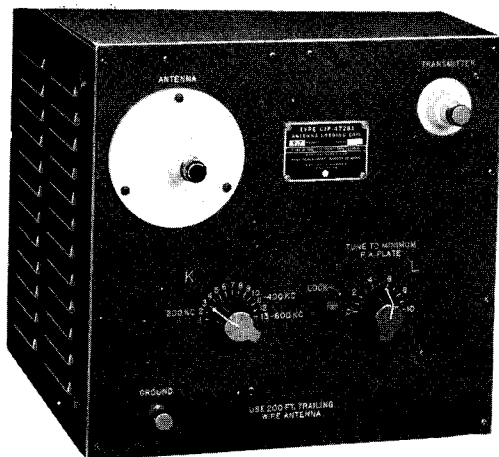

Figure 1-10. Type CU-25/ART-13 Antenna Loading Coil



Figure 1-11. Type CU-26/ART-13 Antenna Loading Coil



Figure 1-12. Type CU-32/ART-13A Antenna Loading Coil

## 12. INTERCHANGEABILITY OF UNITS.

Unit Description	Navy Type Designation	Army-Navy Type Designation	Model ATC	AN/ART-13
Aircraft Radio Transmitter	—52286	T-47/ART-13	X	X
Power Control Unit	—23333	DY-11/ART-13	X	X
Dynamotor (Russell)	—21931		X	X
Power Control Unit	—23333	DY-12/ART-13	X	X
Dynamotor (Wincharger)	—21932		X	X
Pilot's Control Unit	—23330	C-87/ART-13	X	X
Pilot's Control Unit		C-740/ART-13	X	X
Antenna Loading Coil (200 kc to 600 kc)	—47281	CU-25/ART-13	X	X
Antenna Loading Coil (200 kc to 600 kc)		CU-32/ART-13A	X	X
Antenna Loading Coil (500 kc to 1500 kc)	—47282	CU-26/ART-13	X	X
Antenna Shunt Capacitor	—481628	CU-24/ART-13	X	X
Quartz Crystal Assembly (200 kc)		CR-2-B/U (200 kc)	X	X
Transmitter Mounting Plate for T-47/ART-13		MT-283/ART-13	X	X
Shock Mounting Base for T-47/ART-13		MT-284/ART-13	X	X
Mounting Plate for CU-26/ART-13		MT-162/ART-13	X	X
Mounting Plate for C-87/ART-13		MT-163/ART-13	X	X
Mounting Plate for DY-11/ART-13 or DY-12/ART-13		MT-164/ART-13	X	X
Shock Mounting Base for CU-32/ART-13A		MT-198/ART-13A	X	X

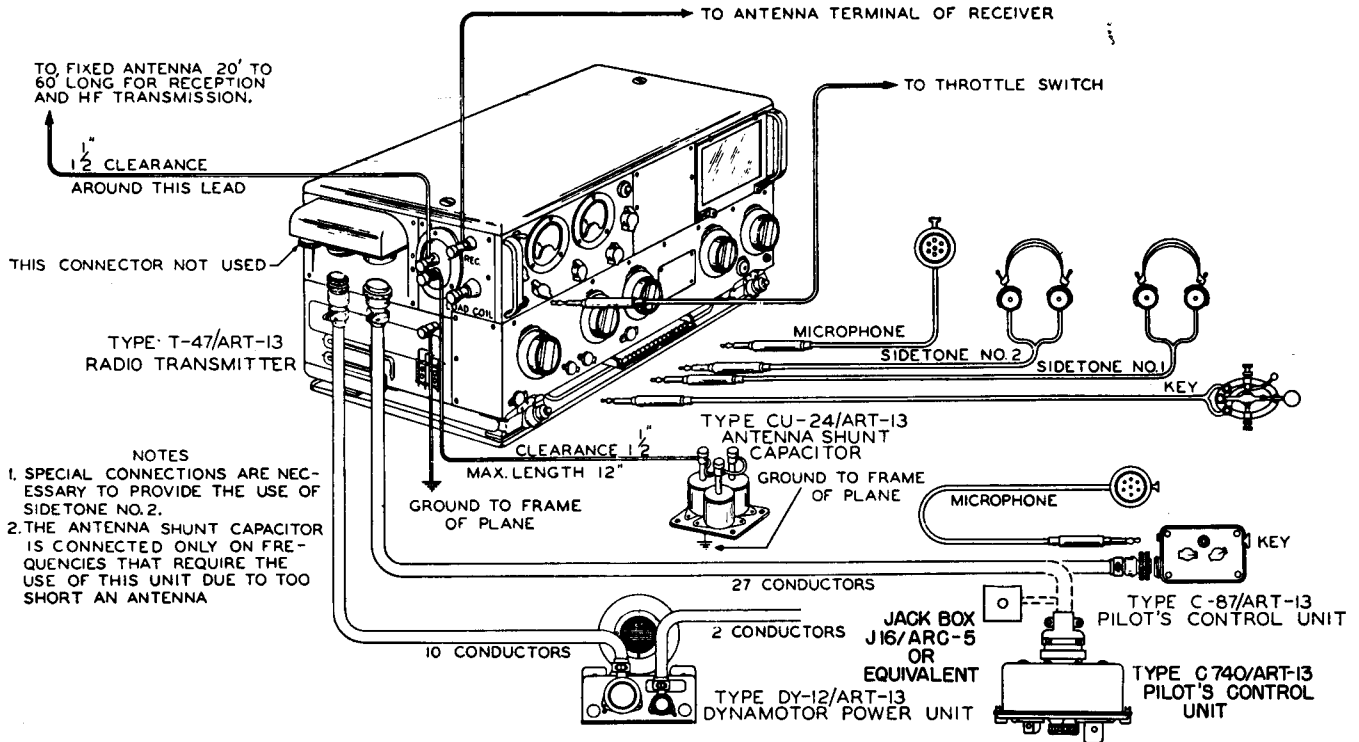

Figure 2-1. Model AN/ART-13 High Frequency Installation Diagram

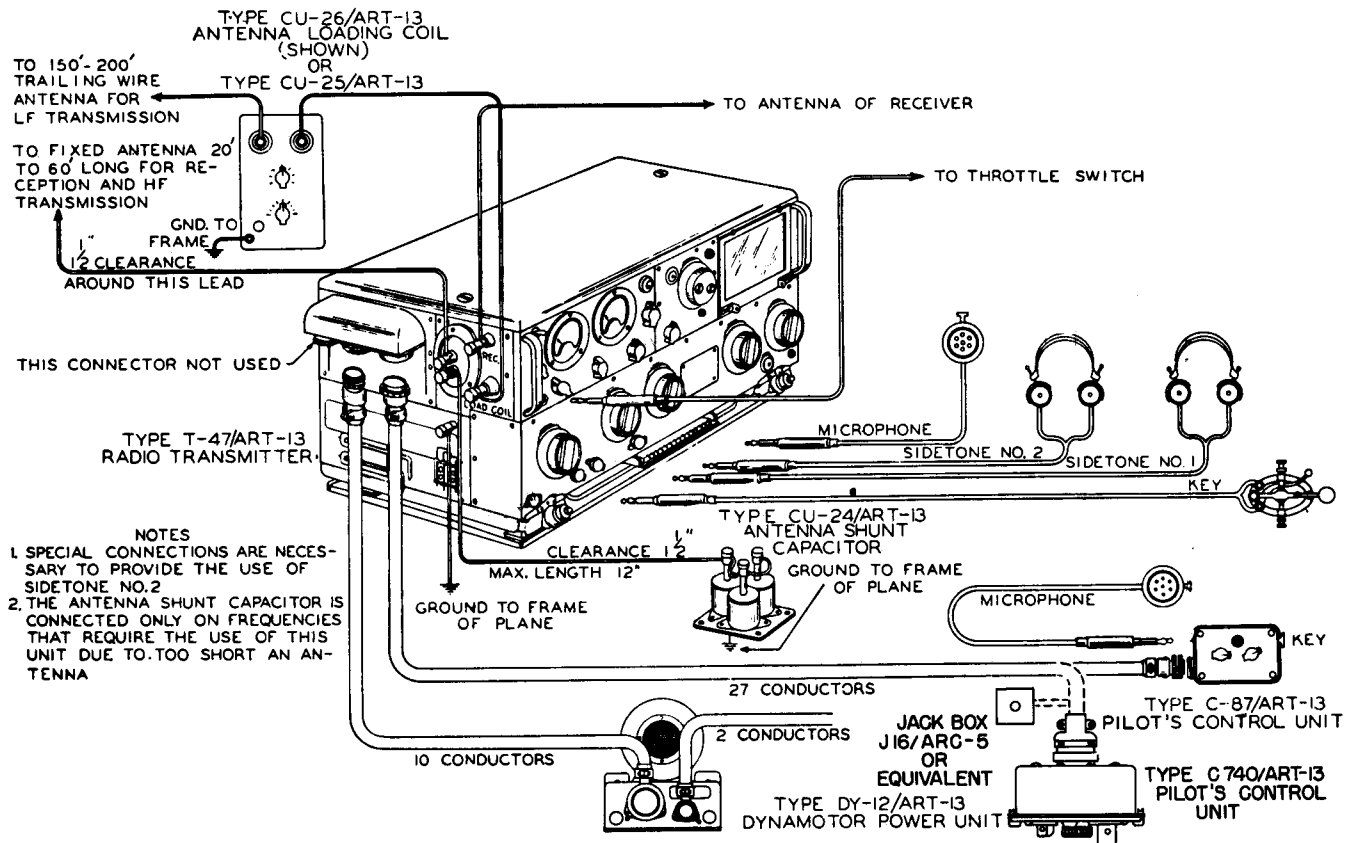

Figure 2-2. Model AN/ART-13 Installation Diagram Including Special Low Frequency Units

Revised 1 May 1953

## SECTION II

### INSTALLATION AND ADJUSTMENT

#### I. INSTALLATION.

*a. UNCRATING.*—Open packing crates with care. When crates are marked with arrows to indicate upright position, remove the covers only and lift units out carefully. Search all packing material for small packages. Inspect cables and wiring and be sure that all terminal connections are tight. Inspect each unit for loose screws and bolts. Be sure that all controls such as switches, dials, etc., work properly. All claims for damage should be filed promptly with the transportation company. If a claim for damage is to be filed, the original packing case and packing material must be preserved.

#### *b. GENERAL.*

(1) Figure 2-2. shows an AN/ART-13 installation with all of the accessories necessary for transmission on any frequency within the frequency range of the transmitter and with the transmitter control from either the transmitter panel or from a remote position. If the fixed antenna has sufficient capacity the Type CU-24/ART-13 Antenna Shunt Capacitor Unit may be omitted from the installation. Figure 2-1. shows a high frequency AN/ART-13 installation which may be used if low frequency (200 kc to 1500 kc) emission is not required.

(2) The first step in preparing the transmitter for installation is to check the vacuum tubes and calibration crystal for placement in the proper sockets. All tubes and crystal unit can be installed from the top of the transmitter unit. To remove the transmitter cabinet cover, loosen the cover holddown screws and lift the cover upward.

#### *c. TUBES.*

(1) The tube placement diagram, figure 2-3. consists of an outline drawing of the top view of the transmitter unit with cover removed. This drawing shows the location of all vacuum tubes and illustrates the operation of the tube clamps. Also refer to figure 6-19. page 6-36.

(2) All plate lead connectors should be placed firmly on the plate caps of 811, 813, 837 and 1625 tubes and tube clamps locked.

#### *d. CRYSTAL.*

(1) The quartz crystal has been carefully calibrated, checked and sealed in the holder at the factory.

(2) The Type CR-2-B/U (200 kc) Crystal Unit is designed to mount in a special two terminal receptacle.

(3) The crystal unit should be in the two prong receptacle in the extreme rear right-hand corner of the transmitter as illustrated in figure 2-3.

(4) Replace the cabinet cover and fasten securely with the clamping bolts.

#### *e. OPERATIONAL CHECK.*

(1) It is recommended that the complete equipment be given an operational check before installation. Considerable time and labor may be saved if all units are in working order before installation. Where numerous installations are to be made, it is recommended that a test bench be set up so that each equipment may be given a careful electrical check prior to installation.

(2) In addition to the regular units supplied with the AN/ART-13 Equipment, it will be necessary to procure a 28 volt battery or other source of 28 volts dc, a set of test cables with plugs and cabling of the same type as supplied with the equipment, a set of earphones (600 ohm impedance), a single button carbon or dynamic microphone similar to the microphone that is to be used in actual operation of the equipment, a telegraph key and a dummy antenna load consisting of from 3 to 5 ohms of resistance in series with approximately 100 mmf of capacity.

#### **Note**

Make certain that the microphone circuit switch, S201, is in the correct position for the type of microphone that is being used.

(3) Using the above mentioned accessories, carefully check the operation of the transmitter unit, the dynamotor power unit, and the pilot's control unit. Check the equipment with all types of emission and both remote and panel control. Refer to Section III for operating instructions. If



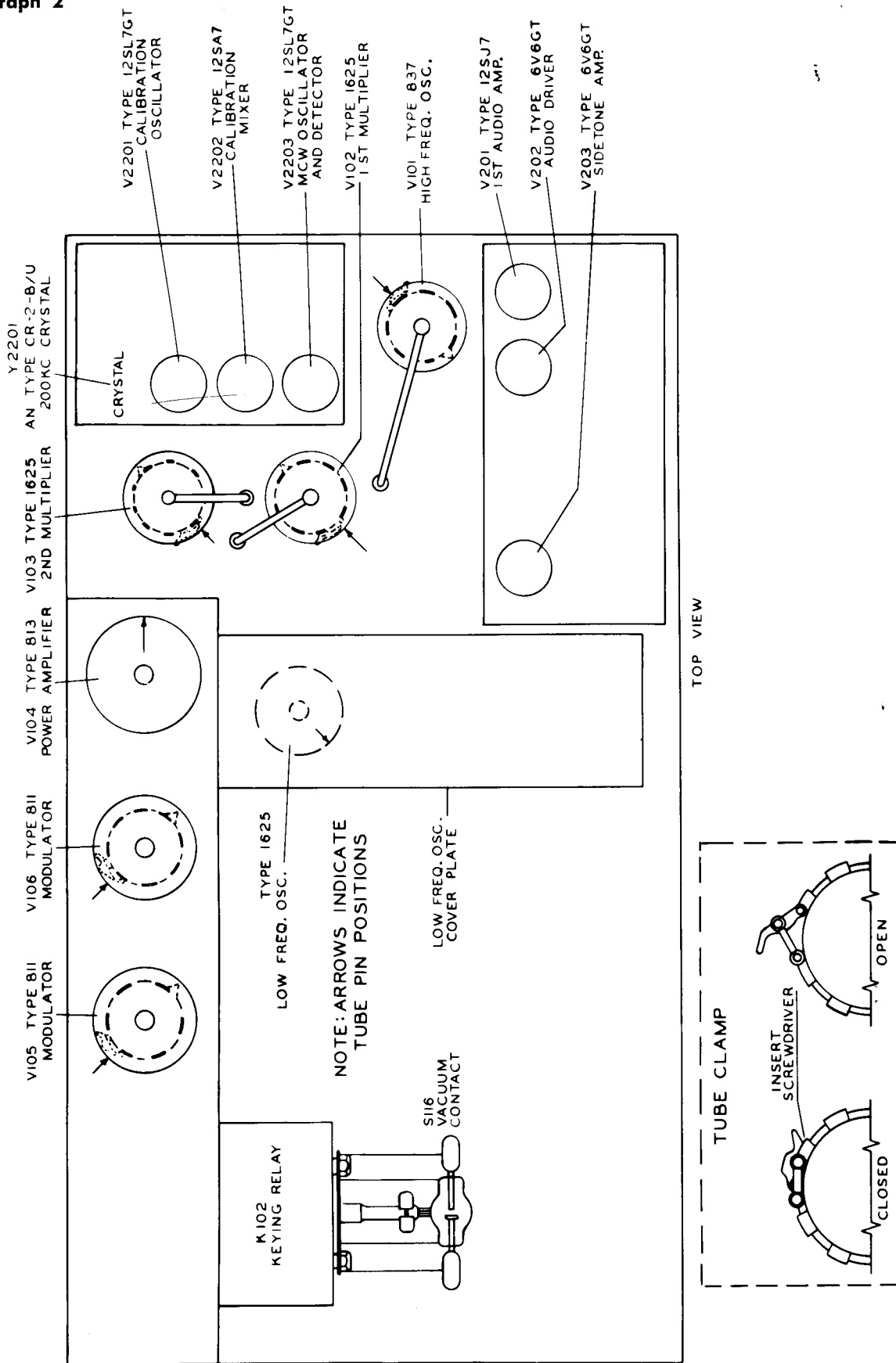

Figure 2-3. Tube Placement Diagram

any trouble is found, repair will be much less difficult on the work bench than in the aircraft after installation. After the equipment has been carefully checked, the installation in the aircraft may be made.

*f.* MOUNTING OF UNITS.

(1) TYPE T-47/ART-13 TRANSMITTER UNIT.

(a) Figure 8-1, page 8-1, 2 shows the outline dimensions of the transmitter unit.

(b) The transmitter unit is equipped with a detachable mounting which has rubber shock mounts incorporated in it to reduce to a minimum the effect of the vibration and shock encountered in normal service. Mounting plate MT-283/ART-13 serves as a bottom cover for the transmitter and provides facilities for attachment to the shock Mounting Base MT-284/ART-13. Refer to figure 2-4.

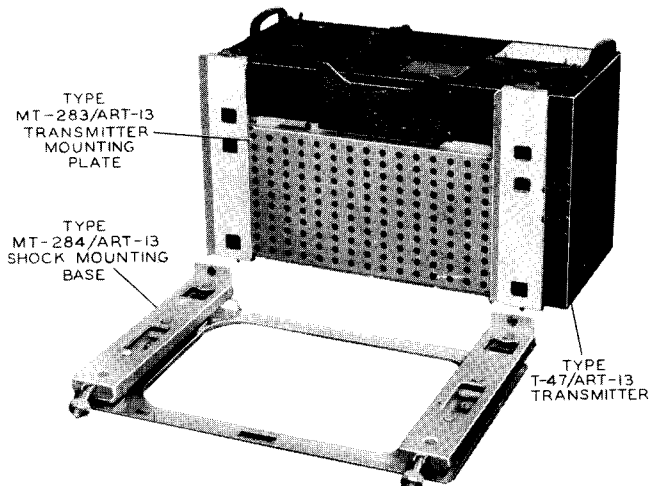

**Figure 2-4. Type T-47/ART-13 Transmitter Mounting Plate MT-283/ART-13 and Mounting Base MT-284/ART-13**

(c) Mounting Base MT-284/ART-13 should be bolted securely in the transmitter mounting position. Refer to figure 8-3, page 8-5, 6 for mounting dimensions. Enough space should be left on the right-hand side and rear of the cabinet to permit the free circulation of air around and through the cabinet. Mounting Base MT-284/ART-13 is provided with twelve mounting holes to pass size number 10 screws. Sufficient space should be allowed on the left-hand side of the cabinet for installing the inter-unit connecting wires and to provide sufficient clearance for the antenna leads.

(d) When Mounting Base MT-284/ART-13 has been securely bolted to the mounting position, the transmitter may be lowered on the base and

slid backward until the holes provided in the base engage the pins that protrude from the back of Mounting Plate MT-283/ART-13 on the transmitter. When the unit has been placed, the locking knobs on the front edge of the base should be raised and rotated in a clockwise direction until the catches provided on transmitter Mounting Plate MT-283/ART-13 are engaged. Tighten the knobs securely and fasten with safety wire in the holes provided for the purpose.

(2) DYNAMOTOR POWER UNIT.

(a) Outline Drawing, figure 8-5, page 8-9, 10 shows the overall dimensions of this unit.

(b) The mounting holes are located in the removable base of the unit and are  $9\frac{1}{2}$  inches between centers on the long dimensions. To remove the base, loosen the two knurled nuts on the front of the chassis until the clamps rotate a fraction of a turn and the base plate is released.

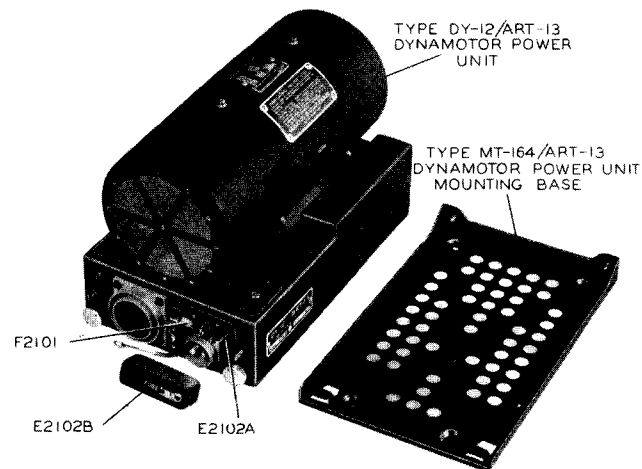

**Figure 2-5. Type DY-12/ART-13 Dynamotor Power Unit and Mounting Base MT-164/ART-13**

(c) Mount the dynamotor unit in any position within the length of the unit interconnecting wires from the transmitter. However, the unit should be accessible to permit the operator to press the "RESET" switches if an overload should occur.

(d) Fasten the Type MT-164/ART-13 Mounting Base securely to the mounting rack with four bolts. Exercise care in securing the mounting base in position so that the torque of the motor will not loosen the mounting bolts. After the base has been securely mounted, place the unit on the base and rotate the locking knob on the front of the unit in a clockwise direction until the clamps are engaged and tightened securely.

(e) Ground the grounding strap, attached to the power control unit, directly to the aircraft frame. See figure 1-6, page 1-4 and figure 2-5, for location of this strap on the power control unit.

(3) TYPE C-87/ART-13 OR C-740/ART-13 PILOT'S CONTROL UNIT.

(a) Mount the Type C-87/ART-13 or C-740/ART-13 Pilot's Control Unit (figure 2-6 and 6-37A) in a position convenient to the pilot. Figure 8-7, page 8-13, 14 shows the outline dimensions and mounting details of the C-87/ART-13. Mount the C-87/ART-13 with the key upward and in a position that will facilitate the operation of the telegraph key when using CW or MCW emission. Figure 8-7A, page 8-13A, 14A shows the outline dimensions of the C-740/ART-13. Mount the C-740/ART-13 in accordance with sub-paragraph (3) (c) below.

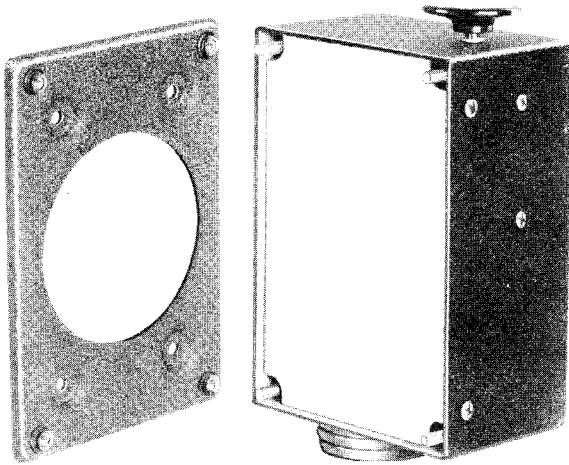

Figure 2-6. Type C-87/ART-13 Pilot Control Unit  
Mounting Base MT-163/ART-13

(b) In mounting the C-87/ART-13, loosen the four retaining bolts to remove the Type MT-163/ART-13 mounting plate. Mount the plate in position with four mounting screws. Sufficient space should be allowed around the unit to permit the removal of the cable connector plug and the insertion of the microphone cord plug in microphone jack.

(c) Mount the Type C-740/ART-13 in a standard console mount as per drawing AND 10480, fastening it in place with Dzus fasteners provided.

(4) ANTENNA SHUNT CAPACITOR.

(a) If operation in the frequency range of 2000 kc to 3000 kc is contemplated and the antenna does not have sufficient capacity to permit the tuning of the output circuit within this frequency

range, the Type CU-24/ART-13 Antenna Shunt Capacitor Unit should be connected between the COND. terminal, just below the ANT. terminal on the left-hand end of the transmitter and ground.

(b) Figure 8-10, page 8-17, 18 shows the outline dimensions and mounting details of the Type CU-24/ART-13 Antenna Shunt Capacitor.

(c) The capacitor should be mounted as close as possible to the left end of the transmitter cabinet so that the lead between COND. terminal J118 and the capacitor unit will be as short as possible. The length of the lead must not exceed 12 inches.

(5) DUMMY LOW FREQUENCY OSCILLATOR.

(a) A Type NX-128/ART-13 dummy low frequency oscillator unit containing a 28 ohm 10 watt filament substitute resistor is installed in the transmitter. The transmitter may be operated normally in every respect except for operation below 2000 kc. Position 13 of control dial "A" should be ignored.

(b) For operation below 2000 kc, the dummy unit may be replaced by either one of the low frequency oscillators, Type O-16/ART-13 (200 kc to 1500 kc) or Type O-17/ART-13A (200 kc to 600 kc). Instructions for replacement may be found in the MAINTENANCE section of this manual.

(6) LOADING COILS.

(a) Three antenna loading coil units are available for use with this equipment. The loading coil to be used depends on the frequency selected for low-frequency operation. If the frequency selected is from 200 kc to 600 kc, either Type CU-25/ART-13 or Type CU-32/ART-13A Antenna Loading Coil should be used, but if the frequency is from 500 kc to 1500 kc the Type CU-26/ART-13 Antenna Loading Coil should be used.

(b) Mounting instructions for all models of the Antenna Loading coil unit are outlined below. Either of the 200 kc to 600 kc antenna loading coil units, or a single 500 kc to 1500 kc. Antenna loading coil unit, or both, may be mounted near the transmitter.

1. TYPE CU-25/ART-13 ANTENNA LOADING COIL.

a. Installation drawing, figure 8-8, page 8-15, 16, shows the outline dimensions and the distances between centers of the mounting holes for the Type CU-25/ART-13 Antenna Loading Coil.

b. The loading coil may be mounted using holes on either of the two sides, top, bottom, or rear of the cabinet. The unit should be mounted

within easy reach of the transmitter unit to facilitate adjustment of the controls on the panel when making tuning adjustments for low-frequency operation.

c. The mounting centers on the sides of the cabinet are 7-3/8 inches by 7-5/8 inches and on the top, bottom and rear 7-5/8 inches by 9-1/8 inches. All mounting holes are drilled to accept number 8 screws.

d. Before the cabinet can be mounted, the front panel must be removed. Remove the panel securing screws and pull the panel forward. All unit components are attached to the panel,



(d) Plug receptacle J107 is not used. The protector cap, part number 371 1069 00, should remain in place at all times.

(2-A) TYPE CU-32/ART-13A ANTENNA LOADING COIL.

(a) Figure 8-8B, D, page 8-16C, shows the outline dimensions and installation detail for the Type CU-32/ART-13A Antenna Loading Coil.

(b) Mount Antenna Loading Unit at a height convenient for operation of controls and within easy reach of the transmitter. A clearance of at least 6 inches should be provided between electrical terminals on each side of this unit and surrounding objects.

(c) Figure 8-8A, B, page 8-16A, shows outline dimensions of Mounting Base MT-198/ART-13A. Required clearances, mounting hole location and banding instructions are also shown in these figures. The mounting base may be installed on the top of, or hung upside down from a flat surface. Shock mounts must be assembled differently when the loading unit is suspended from the mount. Instructions for proper assembly are shown in figure 8-8A. The loading coil unit may be mounted on the top of the mounting base on its top, bottom or back or it may be suspended from the mounting by its top, bottom or back.

(d) Mounting Base MT-198/ART-13A is mounted to the structure of the aircraft by means of four 1/4" screws (see figure 8-8A for location of holes).

(e) After mounting base has been installed, place loading unit in position on mounting plate and secure by closing all four snap slides (one on each corner of the case). Tie wire the four snap slides.

(3) ANTENNA CONNECTIONS.

(a) Five terminals on the left-hand end of the transmitter cabinet provide terminals for connecting the antenna, the antenna shunt capacitor, the load coil, the receiver antenna terminal and a ground.

(b) The fixed aircraft antenna should be connected to the ANT. terminal, J109; the upper terminal of the pair that is brought out through the insulating corona shield.

(c) The leads within the fuselage should be as short as possible to keep RF losses to a minimum. It is recommended that bare wire supported on ceramic insulators be used wherever practicable for all antenna connections.

(d) The Type CU-24/ART-13 Antenna Shunt Capacitor when used should be connected

between the lower terminal of this pair, J118, engraved COND., and ground. A heavy, stranded conductor should be used to make the connections and the lead between COND. connector J118 and the capacitor should clear all metal objects by at least an inch and a half.

(e) A good ground connection to the frame of the ship should be made to the terminal designated as GROUND, J113, using heavy bus or a heavy stranded conductor and keeping the lead as short as practicable.

(f) The connection from the transmitter to the loading coil should be made from the terminal, J117, designated as LOAD COIL on the transmitter cabinet to the TRANSMITTER terminal located on the antenna loading coil panel. A heavy stranded conductor should be used to make the connection. The lead-in to the long wire trailing antenna should be connected to the ANTENNA terminal on the loading coil panel.

(g) Connect the GROUND terminal on the load coil to the airplane frame at a point as near as possible to the point at which the transmitter proper is grounded.

(h) To complete the installation connections, connect a jumper between the antenna terminal on the receiver and the RECEIVER terminal, J110, on the transmitter.

(4) OPTIONAL AUXILIARY CONNECTIONS.

(a) A connection for individual keying of double sidetone, utilizing auxiliary jack J105 in connection with SIDETONE jack J104 can be made by connecting jumper wires from terminals numbers 23 to 27 and 25 to 26 of remote jack J106.

(b) The connection for single keyed sidetone plus a receiver disabling circuit, utilizing auxiliary jack J105 in connection with SIDETONE jack J104, can be made by connecting a jumper wire between terminal number 26 and terminal number 27 of remote jack J106. Terminal number 23 of remote jack J106, is connected to an arm of keying relay K102, terminal number 24 is connected to a normally closed contact with the arm and terminal number 25 is connected to a normally open contact with the arm. Terminals 23, 24 and 25 can be used for the receiver disabling circuit, connected as desired.

(c) Connection for the purposes described can be made in a dummy plug used in remote jack J106 if REMOTE control of the transmitter is not desired. In case REMOTE control of the transmitter is desired it will be necessary either to use a junction box with the remote cable or to loosen

the cable connector plug cover to bring out separate connections from the remote plug and "jumper" the proper terminals together or to splice the cable (*Refer to figure 8-11. page 8-19, 20.*).

*j.* EXPLANATORY NOTES REFERRING TO  
INSTALLATION DRAWINGS.

*(Figure 2-1. and Figure 2-2. page 2-0.)*

(1) Microphones, earphones, telegraph key and the throttle switch connector cord and associated plugs are not supplied as a part of this equipment.

(2) The transmitter unit, the antenna load coil and the antenna shunt capacitor unit need not be mounted near the pilot, but the three units

should be mounted as close together as possible.

(3) Ground connections should be made to the frame of the aircraft. Keep all leads as short as practicable with only enough slack to allow free movement of the unit on the shock mounts.

(4) Mount the antenna shunt capacitor in a position such that the lead from COND. terminal J118 to the Type CU-24/ART-13 Antenna Shunt Capacitor is not longer than 12 inches and has at least 1½ inches of clearance to all metal parts and to the other wires.

(5) The leads from the ANT. and LOAD COIL terminals to the fixed antenna and load coil unit and the lead from the load coil unit to the long wire antenna should be made using heavy, bare bus and should be supported on ceramic in-

sulators where necessary. To prevent corona discharge from the antenna leads, do not allow any sharp ends of the leads to project from the binding post terminals. *If the above precautions are not observed, corona discharge and air gap breakdown may occur.* Air gap breakdown and corona discharge will become more pronounced at high altitudes.

(6) Make the connection from the RECEIVER terminal to the receiver with either bus or a flexible stranded lead.

(7) Careful consideration should be given to the length of leads to permit the free movement of the transmitter unit on the shock mounts. It is also necessary to allow enough slack in the antenna and ground leads so that the vibration encountered in normal service will not pull the leads from the clip type connector terminals. Allow enough additional slack in the inter-unit connecting wires to permit free movement of the transmitter unit on the shock mounts.

## 2. ADJUSTMENT.

### WARNING

Operation of this equipment involves the use of high voltages which are dangerous to life. Operating personnel must observe all safety regulations at all times.

### IMPORTANT

If an overload occurs during the process of circuit adjustment or transmitter operation, either or both overload relays may operate to break the primary power circuit. To return the relays to the normally closed positions, press the "reset" buttons on the dynamotor unit. Under no circumstances should the transmitter be actually operating (key down or microphone push button closed) when the emission selector switch, S110, is being operated. Such operation, especially at high altitudes, can cause an arc to occur and sustain between the contacts of CW relay K103.

### CAUTION

DO NOT MOVE CONTROL "E" ACROSS THE SPACE BETWEEN 100 AND 200 OR BETWEEN 0 AND 100 WHILE THE TEST SWITCH, MICROPHONE BUTTON, or KEY IS CLOSED. AN INTERNAL SWITCH WILL BE DAMAGED IF THIS PRECAUTION IS NOT FOLLOWED.

### a. GENERAL.

(1) The AN/ART-13 Equipment may be controlled from either the panel or a remote position. However, all tuning and Autotune adjustment must be made with the LOCAL-REMOTE switch, S107, in the LOCAL or panel control position. Manual operation of all dials is possible without disturbing the position of the Autotune stop rings if the CHANNEL selector switch, S108, is operated to the MANUAL position and the Autotune system allowed to operate.

(2) The frequency determining and tuning controls on the transmitter front panel have been assigned letter designations to aid in identifying the various dials. Reading from left to right, these controls are designated as follows: "E", "C", "D", "A", and "B".

(3) The following paragraphs list the control designations together with the function of each: Refer to figure 3-1, page 3-1.

(a) CONTROL "A"—"HIGH FREQUENCY TUNING—COARSE".—Control "A" operates the high frequency oscillator range change switch, S101, the first multiplier range change switch, S102, the second multiplier range change switch, S103, the oscillator selector switch, S114, and the second multiplier operating switch, S115. Twelve positions of the control have been assigned to the high-frequency range, with the dial calibrated in megacycles. Position 13 transfers frequency control from the high-frequency oscillator tube, V101, to the low-frequency oscillator tube, V401.

(b) CONTROL "B"—"HIGH FREQUENCY TUNING—FINE".—Control "B" determines the position of the core in the variable inductor, L101; the high-frequency oscillator grid tuning inductor. The dial is calibrated from zero to 100. The dial may be rotated a maximum of 20 revolutions, giving a total of 2000 dial divisions for each position of Control "A". The revolution counter, the small dial near Control "B", records the whole revolutions and the fraction of a revolution is indicated by the dial calibration. The indicating mark of dial "B" may be moved approximately forty dial divisions providing a ready means of re-calibration on the high frequencies.

(c) CONTROL "C"—"ANTENNA TUNING—COARSE".—Control "C" operates the switch, S113; the multi-circuit output network switch. Thirteen positions of the control are available. The setting of the dial for any frequency is largely dependent upon the antenna being used. In general, the frequency at which the an-



tenna loading network will tune increases as the dial "C" reading is increased. *The setting of this control is critical.* If the dial is not set accurately the carrier control relay cannot be operated. An interlock switch, S113D, operated by Control "C", breaks the coil circuit of keying relay K102 during the operation of network switch S113, to prevent the burning of switch contacts. If Control "C" is not set properly, the keying relay, K102, will not operate and the transmitter will not function. The network switch varies the tap on the loading inductance, L113, and the capacity in the circuit. In the first position all of the inductance is in the circuit and in the seventh position this inductance is completely shorted out. Between ranges seven and eight a switch operates to cut in the ceramic padding condensers, various combinations of which are used from ranges eight to thirteen. In addition, a small inductor is connected across the variometer on range thirteen by the operation of one of the switch arms.

(d) CONTROL "D"—"ANTENNA TUNING—FINE".—Control "D" operates the variometer section of the output network. As in the case of the other controls, increasing the dial reading increases the frequency at which the network will tune; that is, the inductance is a maximum at zero and a minimum at 100.

(e) CONTROL "E"—"ANTENNA LOADING".—Control "E" operates the large variable loading capacitor, C125, and the associated switch, S113A. The dial has two scales, one graduated from 0 to 100 and the other from 100 to 200. When the control is in the range 0 to 100 the switch, S113A, is in the operated position and connects the padding capacitor, C124, in parallel with C125. When the dial is in the range 100 to 200, switch S113A is open, removing the padding capacitor from the circuit. A continuous extended range of capacity is obtained by this means. Maximum capacity is at 0 and minimum capacity is at 200.

(f) CONTROL "F"—"LOW FREQUENCY TUNING — COARSE".—Control "F" operates S401 in the Type O-16/ART-13 LFO (S2601\* in the Type O-17/ART-13A LFO) altering the grid circuit capacity. S401 also controls the position of the grid inductor tap on the Type O-16/ART-13 LFO only.

(g) CONTROL "G"—"LOW FREQUENCY TUNING — FINE".

1. Control "G" adjusts the position of the slug in the low-frequency oscillator grid in-

ductor. The dial which is similar to Control "B" is divided into 100 divisions and may be rotated twenty revolutions, giving a total of 2000 dial divisions for each setting of Control "F". A small dial, the revolution counter, shows the number of whole revolutions that the dial makes. The indicator mark or vernier scale may be moved approximately 40 dial divisions by operating the CORRECTOR knob.

2. Because only one Autotone channel position has been assigned to the frequency range below 2000 kc, the LOW-FREQUENCY TUNING controls are independent of the Autotune. After the oscillator frequency within the above range has been set, Control "G" should be locked in position.

3. The frequency determining Control "G", has been provided with a movable indicating mark to permit the adjustment of the zero setting of the dial to compensate for the slight variation in oscillator circuit components and the consequent difference in calibrations.

4. The microphone circuit selector switch, S201, is located beneath the tuning chart on the transmitter front panel. Before making any tuning adjustments release the chart holder clips and swing the holder upward to reveal the microphone circuit switch and the sidetone OUTPUT level control S202. Operate S201 to the CARBON or DYNAMIC position depending on the type of microphone to be used with the equipment.

b. RADIO TRANSMITTER T-47/ART-13 ADJUSTMENT FOR OPERATION.—The following procedures are for setting up the transmitter for Autotune operation. If MANUAL operation is desired, set the CHANNEL switch on the MANUAL position and follow these instructions with the exception that the locking bar should not be moved. MANUAL operation will not interfere with any of the channels set up for Autotune operation if the locking bar is not loosened, nor will setting up any channel in accordance with the following procedure interfere with any other channel previously set up. Channeling the Autotune with the locking bars loose will completely eliminate the settings previously set up for the channel that was cycled and may cause settings for some or all of the other channels to shift.

(1) CW OPERATION IN THE RANGE 2000 KC to 18,100 KC.—The following procedure is to be used for setting up the transmitter for Autotune operation on a desired frequency on any one of the ten high frequency channels:

(a) Place the antenna selection switch on

the FIXED position if a switching unit is used in the installation. If a knife type of change-over switch is used, place it in the proper position for fixed antenna operation.

(b) Make certain that the microphone, key, and throttle switch (T.S.) jack circuits are open.

(c) Place the LOCAL-REMOTE switch in the LOCAL position. Place the CALIBRATE-TUNE-OPERATE switch in the TUNE position as a precautionary measure during preliminary tuning.

(d) Place the EMISSION selector switch in the VOICE position.

(e) Check primary voltage by moving metered circuit selector switch to the BATTERY VOLTAGE position. Usable primary voltage is indicated when the meter needle is within the light shaded area under BATTERY. A primary voltage of 28 volts will cause the meter needle to read at the top edge of this shaded area and a primary voltage of 24 volts will cause the meter needle to read at the lower edge of this shaded area.

(f) Place the CHANNEL switch in the position corresponding to the channel it is desired to set up. (If MANUAL operation is desired, place the CHANNEL switch in the MANUAL position.) If the Autotune system begins to run, allow it to complete the cycle of operation before proceeding. The red pilot light on the front of the transmitter will light when the Autotune cycle is completed and the transmitter will be ready for tuning adjustments or operation.

(g) Line up the movable indicator mark with the stationary indicator mark above Control "B" by means of the CORRECTOR knob located below and to the right of Control "B".

(h) Unlock all five controls by holding the dial and turning the locking bar  $\frac{1}{4}$  turn in a counterclockwise direction. (If MANUAL operation is being used, the locking bars should not be loosened.)

(i) Set Control "C" on Position 1. Check the position of the control against the indicator mark on the transmitter panel. THE SETTING OF THIS CONTROL IS CRITICAL. The transmitter will not operate if Control "C" is not set on numbered position.

(j) Find the desired frequency in the calibration tables in Section III, and note the nearest crystal check point (marked in heavy black type).

(k) Set Control "A" to the position corresponding to the number in column A at this crystal

check point. Check the position of the control against the indicator mark on the transmitter panel. THE SETTING OF THIS CONTROL IS CRITICAL. The transmitter will not operate if Control "A" is not set accurately.

(l) Set Control "B" to the position corresponding to the number in column B at this crystal check point.

(m) Set the power level switch to the CALIBRATE position and listen in the sidetone circuit for a beat note while rotating Control "B" back and forth about its position given for the crystal check point. Set Control "B" on the position that gives zero beat and turn the power level switch to the TUNE position.

(n) Set the movable indicator mark by means of the CORRECTOR knob near Control "B" so that the setting of Control "B" is the same as in column B at this crystal check point.

(o) Refer to the calibration tables found in Section III and obtain the correct setting of Control "B" for the desired operating frequency. If the operating frequency desired is between those given in the table, refer to Section III paragraph 3, d. for instructions to obtain correct dial settings.

(p) Set Control "B" to the reading obtained in (o) above. Be sure to set the reading to the movable indicator mark.

(q) Lock Control "A" by first noting its reading, rotating the dial COUNTERCLOCKWISE one-eighth turn or against the stop if the stop is within an eighth of a turn, and then rotating it CLOCKWISE TO, BUT NOT PAST the reading on which it had been set. Carefully turn the locking bar clockwise without touching the knob until it is tight with a firm but not heavy pressure. Repeat this procedure for Control "B". Further pressure on the dial (either Control "A" or "B") in a clockwise direction should not cause the dial to move beyond the original setting. If it does, unlock and repeat the locking procedure, making certain that the original dial setting obtained in paragraphs 10 and 14 are used. (If MANUAL operation is being used the locking bars should be left in the locked position.)

(r) Place Control "D" on zero.

(s) Place the EMISSION selector switch on the CW position.

(t) Check the grid drive to the final amplifier by placing the metered circuit selector switch on the P.A. GRID position, closing the TEST

switch, and noting the reading on the meter. It should read in or slightly above the light shaded area under P.A. GRID. If it does not, Control "A" may not have been positioned accurately or the transmitter may be defective. Check the trouble before proceeding. See Note at the end of these instructions on P.A. GRID.

(u) Place the metered circuit selector switch on the P.A. PLATE position.

(v) Hold the TEST switch closed and rotate Control "B" throughout its range, seeking a plate current dip indicating resonance of the circuit.

(w) If no resonance dip is found, set Control "C" on the next higher position and rotate Control "E" again, seeking a dip in plate current.

(x) Repeat paragraph (w) above until the resonance dip is found or until Control "C" is set on position 8 and resonance has not been found.

**Note**

See note on USE OF SHUNT CAPACITORS following this procedure if frequency of operation is below 3000 kc and a short fixed antenna is being used.

(y) If resonance was found on Positions 1 to 7 inclusive on Control "C", place the power level switch in the OPERATE position.

(z) Load the power amplifier by increasing the reading on Control "D" in steps, re-resonating with Control "E" each time. When Control "D" has been rotated throughout its range, set Control "C" on the next higher position, Control "D" on zero, and repeat. Continue this process until the resonance dip falls in the light shaded area marked CW on the plate meter. The correct loading of the final amplifier tube with a 28 volt primary voltage is 100 on the plate meter. It may not be possible in all cases to load the amplifier tube exactly to this value, but any value of loading which is in the light shaded area marked CW will be satisfactory.

**Note**

If the resonance dip causes the plate current to fall to a very low value, Control "C" may be set to the next higher position without moving Control "D", always re-resonating with Control "E" each time as before. Fine adjustment must still be made by means of Control "D". With antennas more than 55 feet in length and on frequencies below 3000 kc, it may not be possible to load the final

amplifier to the light shaded area marked CW before Control "E" reaches zero. If this happens, set Control "E" on zero and resonate with Control "D". This will give the best operation obtainable under these conditions.

(aa) If resonance was not found before Control "C" was set on position 8, leave Control "C" on position 8, set Control "E" on zero, and seek the resonance dip in plate current by rotating Control "D" throughout the range 0 to 100.

(bb) If resonance is not found, set Control "C" on the next higher position, rotate Control "D" again, seeking the resonance dip.

(cc) Repeat paragraph (bb) above until resonance is found or until Control "C" has been tried on Position 13 without finding a resonance dip.

(dd) If the resonance dip was not found with Control "C" on Position 13, leave that control on Position 13, place Control "D" on 100, and seek the resonance dip with Control "E".

(ee) When resonance is found, place the power level switch in the OPERATE position.

(ff) Load the power amplifier by increasing the reading on Control "E" in steps, re-resonating with Control "D" each time until the resonance dip falls in the light shaded area marked CW on the meter.

(gg) After proper loading of the final amplifier tube has been found by using any of the above procedures, lock Control "C" by noting its reading, rotating the dial counterclockwise about  $\frac{1}{8}$  of a turn, and then rotating it clockwise to, but not past the reading on which it has been set. *Hold the knob* and turn the locking bar clockwise until tight with a firm but not heavy pressure. Further pressure on the dial in a clockwise direction should not cause the dial to move beyond the original setting. If it does, unlock and repeat the locking procedure, making certain the original dial setting is used. Repeat this procedure with Controls "D" and "E". If MANUAL operation is being used, the locking bars should be left in the locked position.

(hh) Check tuning and locking by holding the TEST switch closed while placing a small force on each knob in turn in the clockwise direction. If all dials are locked properly no detuning will result (Do not use this test when in MANUAL position).

(ii) Repeat the above procedure for each

high frequency Autotune channel set up on the transmitter.

#### Note

The P.A. GRID meter reading when Control "A" is in position 7 is usually at the lower edge of the light shaded area. It is permissible for the grid meter reading for this particular setting (Control "A" on 7) to be 50 on the meter scale and still be satisfactory. A lower meter reading is not satisfactory and the transmitter should be repaired or aligned per the instructions in the Maintenance Section. If the Control "A" is not set accurately it is possible for some of the multiplier switches to be in between contact positions and this results in loss of grid drive to the final amplifier tube in addition to burning of contacts. Set Control "A" accurately.

### WARNING

Exercise care to avoid operation on a harmonic of the desired frequency. This will be avoided in most cases by following the outlined procedure for tuning adjustment into a fixed antenna. However, for frequencies between 2000 to 3000 kc an antenna shorter than approximately 50 feet may be too short for the tuning elements in the transmitter to resonate at the fundamental frequency. Therefore, the first resonance indicated by the tuning adjustment procedure may be a harmonic of the desired frequency. To determine whether this is true, follow the tuning procedure outlined in paragraph b., (2) following.

#### (2) USE OF ANTENNA SHUNT CAPACITORS.

(a) For operation into short antennas (less than 50 feet) at frequencies between 2000 and 3000 kc it may be necessary to connect ANTENNA SHUNT CAPACITOR CU-24/ART-13 to the COND. post on the transmitter. The tuning procedure for the transmitter when using this shunt capacitor is identical to the procedure without shunt capacitors. The power output from the transmitter is reduced when used on frequencies higher than those which require its use. For this reason, the capacitor should not be used unless necessary and then only on those channels requiring it. This obviously cannot be done if the

transmitter is to be operated from a remote position since no provisions have been provided to automatically switch the shunt capacitors in or out. In this case the capacitor should be used only if it is desired to set a channel in the frequency range wherein the antenna cannot be resonated by the tuning elements in the transmitter itself, and it must be left in for all channels regardless of the reduction of power. Connect only the capacity necessary to tune the lowest frequency used. This can be done by connecting one, two, or three of the capacitors in parallel according to the amount of capacity needed. To determine the lowest frequency that can be tuned with a given number of capacitors for a particular antenna, proceed as follows:

1. Connect one or more capacitors.
2. Place the LOCAL-REMOTE switch to the LOCAL position.
3. Place the EMISSION switch on the VOICE position.
4. Place the CHANNEL switch on the MANUAL position.
5. Place the METER SELECTOR switch on the P.A. PLATE position.
6. When the Autotune motor stops and the pilot light comes on, set dial A on Position 2 and dial B on 2000.
7. Tune and load the power amplifier according to instructions contained in the regular procedure.
8. Attempt to repeat the above tuning and loading procedure with each of the following combinations of settings in turn.

Control A	Control B
2	1500
2	1000
2	500
Control A	Control B
1	1500
1	1000
1	500
1	100

#### Note

The setting of dial E for each successive trial will be lower than for the preceding trial.

(b) If one of the above combinations of dials A and B cannot be loaded without going to a HIGHER setting of dial C than for the preceding combination, place dial C on Position 1, dial D on zero, and dial E on zero. Then rotate dial B

towards a higher reading while holding the TEST switch closed until the plate current shows a resonance dip. Turn the transmitter off and look up the frequency in the calibration tables found in Section III corresponding to the combination of dials A and B found by this process. It may appear that proper operation is obtained by continuing the tuning procedure to HIGHER positions of dial C, but this results in operation on a harmonic of the desired frequency and will result in complete lack of communication.

(3) CW OPERATION IN THE RANGE  
200 TO 1500 KC.

(a) Place the antenna change-over switch in the position which selects the antenna that is desired. If the trailing wire is to be used, let it out 200 feet if operation is below 1100 kc and 150 feet if operation is above 1100 kc.

(b) Place the LOCAL-REMOTE switch in the LOCAL position.

(c) Place the EMISSION selector switch in the VOICE position.

(d) Place the CHANNEL switch in the L. FREQ. position.

(e) Unlock Controls "A" and "C", place Control "A" on Position 13 and Control "C" on Position 1. Lock them in these positions. (If MANUAL operation is being used, place Control "A" on Position 13 and Control "C" on Position 1 without unlocking them.)

(f) Set the movable indicating mark in line with the stationary indicating mark above Control "G" by means of the CORRECTOR knob located below and to the right of Control "G".

(g) Find the desired frequency in the CALIBRATION HANDBOOK and note the nearest crystal check point marked in heavy black type.

(h) Set Control "F" to the position corresponding to the number in column F at the crystal check point.

(i) Unlock Control "G" by turning the LOCK knob counterclockwise until loose. Then set Control "G" to the position corresponding to the number in column G at the crystal check point.

(j) Set the power level switch to the CALIBRATE position and listen in the sidetone circuit for a beat note while rotating Control "G" back and forth about its position. Set Control "G" on the position that gives zero beat and turn the power level switch to the TUNE position.

(k) Set the movable indicating mark by means of the CORRECTOR knob near Control "G"

to the reading on Control "G" found in column G at the crystal check point.

(l) Rotate Control "G" to the figure in column G at the desired frequency, setting the reading to the movable indicating mark. Lock the dial.

**Note**

For operation in the 200 to 600 kc range use ANTENNA LOADING UNIT CU-25/ART-13 with Controls "K" and "L" and in the 600 to 1500 kc range use ANTENNA LOADING UNIT CU-26/ART-13 with Controls "H" and "J".

(m) Place Control "K" (or "H" as applicable) on Position 1.

(n) Turn the LOCK knob counterclockwise until loose on Control "L" (or "J" as applicable).

(o) Place the EMISSION selector switch on CW position.

(p) Hold the TEST switch closed and rotate Control "L" (or "J") throughout its range, seeking a plate current dip indicating resonance of the circuit. Be sure metered circuit selector switch is in P.A. PLATE position.

(q) If no resonance was found, place Control "K" (or "H") on the next higher position, hold the TEST switch closed and rotate Control "L" (or "J") again, seeking the dip in plate current.

(r) Repeat (q) above until resonance is found.

(s) Adjust Control "L" (or "J") to the position giving minimum plate current.

(t) Place the CALIBRATE-TUNE-OPERATE switch in the CALIBRATE position.

(u) This completes the tuning procedure as there is no provision in the frequency range of 200 to 1500 kc for exact loading of the transmitter to the light shaded area marked CW on the plate meter. The plate current may read anywhere from 10 to 110.

**Note**

The following operating procedure shall be followed when using CU-32/ART-13A in the 200 to 600 kc range.

(a) Place control "P" on the Antenna Loading Unit on position 1.

(b) Place control "Q" on position 1.

(c) Unlock control "R" and place it on zero.

(d) Hold "Test" switch closed and rotate "R" throughout its range, seeking a plate current dip indicating resonance of the circuit.

(e) If no resonance was found, place control "Q" on the next higher position, hold "Test" switch closed, and rotate control "R" again, seeking the dip in plate current.

(f) Repeat paragraph "e" above until resonance is found or until control "Q" has been tried on all its positions.

(g) If no resonance was found in subparagraph (f) above, set control "P" on the next higher position, control "Q" on position 1 and repeat subparagraphs (d), (e), and (f) above.

(h) Repeat paragraph (g) above until resonance is found.

(i) When resonance is found, lock control "R" in the position giving minimum plate current.

(j) This completes the tuning procedure

when using Antenna Loading Unit CU-32/ART-13A, as there is no provision for exact loading of the transmitter in the frequency range 200KC to 600KC. The plate current may read anywhere between 10 and 120 for normal operation.

**Note**

If the low frequency Autotune mechanism should fail it is necessary only to switch to MANUAL and set Control "A" to position 13 and Control "C" to position 1.

(4) PRECAUTION AGAINST OPERATION ON A HARMONIC OF THE DESIRED FREQUENCY.—It is to be noted that the tuning reactance present in ANTENNA LOADING UNIT

CU-25/ART-13 (200 to 600 kc) may not be sufficient to resonate fixed wire antennas down to 200 kc. It will resonate a 200 foot trailing wire antenna over the frequency range of 200 to 600 kc. The tuning reactance present in ANTENNA LOADING UNIT CU-26/ART-13 may not be sufficient to resonate all fixed wire antennas down to 500 kc. It will resonate a 200 foot trailing wire antenna over the frequency range of 600 to 1100 kc and a 150 foot trailing wire antenna over the frequency range of 1100 to 1500 kc. Care must be exercised to avoid operation on a harmonic of the desired frequency. In the type of tuning network used the antenna is a part of the frequency determining circuit. Therefore, if the antenna is shorter than 150 feet it will not be possible to tune the lower end of the frequency range. The output network is designed to couple antennas longer than 150 feet. To determine the lowest frequency that is possible to tune, tune to a frequency near the high end of the band as follows:

(a) Warm up the transmitter and select the CHANNEL as in the regular procedure.

(b) Set Control "F" on CU-25/ART-13 on Position 3 and Control "G" on 1090.

(c) Set Control "K" on Position 1 and rotate Control "L" throughout its range seeking the plate current dip.

(d) If resonance is not found, move Control "K" to the next higher position and rotate Control "L" throughout its range again. Repeat until resonance is found.

(e) Reduce the setting of the oscillator in 50 kc steps, until Control "K" is on Position 1. Resonate the load coil each time the oscillator frequency is changed. This will be the lowest tunable frequency for this particular antenna.

#### Note

This same procedure may be used for the smaller load coil CU-26/ART-13 by substituting Control "H" for "K" and Control "J" for "L". Set Control "F" on 5 and Control "G" on 821.

#### (5) VOICE OPERATION.

(a) Adjust the transmitter for CW operation according to the procedure, then place the EMISSION selector switch on VOICE position. No further tuning adjustments are necessary.

(b) Be sure the microphone selector switch under the tuning chart on the front panel of the transmitter is in the position corresponding to the type of microphone being used.

(c) Pressing the button on the microphone will start the dynamotor and place the transmitter on the air. Releasing the button on the microphone will stop the dynamotor and remove the transmitter carrier.

(d) When the metered circuit selector switch is in the P.A. PLATE position and with normal modulation, the plate meter will read in the red area above the CW portion of the plate meter and may hit the meter peg (over 200 on the meter scale) with heavy modulation. The plate meter indicates the sum of the power amplifier plate current and the modulator static plate current and therefore, with no modulation being applied, the plate meter reading will be slightly higher in VOICE position than in CW position.

#### (6) MCW OPERATION.

(a) Adjust the transmitter for CW operation according to the procedure, then place the EMISSION selector switch to MCW position. No further adjustments are necessary.

(b) The normal plate meter reading on MCW when the metered selector switch is in the P.A. PLATE position, key down, will be in the light shaded area marked MCW or higher.

#### (7) SIDETONE AMPLIFIER ADJUSTMENT.

(a) The only adjustment available in the audio system is the adjustment of the power output of the sidetone amplifier. The control, S202, is located beneath the tuning chart on the transmitter front panel. The chart holder is hinged and may be swung upward if the clamps on the lower edge of the holder are released. Refer to figure 2-8.

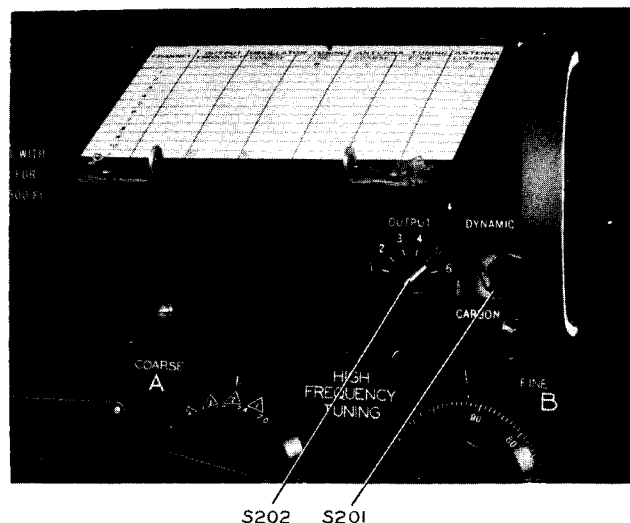

Figure 2-8. Microphone Switch and Sidetone Amplifier Gain Control

(b) Six positions of the OUTPUT control, S202, permit the adjustment of the output available at the SIDETONE jack, J104, from 0.5 volt measured across 125 ohms in Position 1, to 9.0 volts measured across 125 ohms in Position 5, or 18.0 volts measured across 2000 ohms in Position 6.

(c) The approximate output voltages available with the various positions of the OUTPUT switch, S202, are tabulated below:

Switch Position	Output Voltage	Load Impedance (Test)	Maximum Source Impedance
1	0.5 volt	125 ohms	5 ohms
2	1.0 volt	125 ohms	5 ohms
3	2.0 volts	125 ohms	5 ohms
4	4.0 volts	125 ohms	15 ohms
5	9.0 volts	125 ohms	25 ohms
6	18.0 volts	2000 ohms	100 ohms

(d) The following procedure is recommended for the adjustment of the sidetone amplifier output:

1. Insert the earphones cord plug into the SIDETONE jack, J104.

2. Place the sidetone amplifier OUTPUT control (beneath chart holder) in position 1.

3. Place the LOCAL-REMOTE switch, S107, in the LOCAL position.

4. Rotate the EMISSION selector switch, S110, to the CW position. (Applies 1150 volts dc plate potential.)

5. Operate the TEST switch S104 to the "ON" position.

6. While listening to sidetone in earphones advance OUTPUT control one step at a time until desired output signal level is obtained.

7. Release the TEST switch, S104.

To further check the operation and adjustment of the sidetone amplifier circuit, proceed as follows:

8. Rotate the EMISSION selector switch, S110, to the VOICE position.

9. Insert a microphone cord plug into the MICROPHONE jack, J102.

10. Place the microphone circuit selector switch, S201, (beneath chart holder) in the proper position for the type of microphone being used.

11. Press the push-to-talk switch on the microphone, (applies 1150 volts dc plate potential) and with the earphones in place speak into the microphone at a normal level.

12. The level of the voice signal heard in the earphones should be enough above the level

of the normal voice to allow the operator to check the operation of the speech amplifier.

13. If the gain of the amplifier is not high enough to permit the monitoring of the voice signal, the sidetone amplifier OUTPUT control should be advanced one step, or as many steps as are necessary to give satisfactory amplifier output.

14. Release the microphone push-to-talk switch.

#### (8) OPERATION—REMOTE CONTROL.

(a) Place the LOCAL-REMOTE switch, S107, on the transmitter front panel, in the REMOTE position.

(b) If voice operation is contemplated, insert the microphone cord plug into the microphone jack, J602, located near the control cable connector plug on the bottom of the Type C-87/ART-13 Pilot's Control Unit. If the C-740/ART-13 Pilot's Control Unit is being used, the microphone cord plug is inserted into a nearby jack box J22/ARC-5 or equivalent.

(c) Select the Autotune Channel corresponding to the frequency upon which transmission is desired, using the CHANNEL selector switch, S601.

(d) Select the type of emission desired with the emission selector switch, S602. (If CW or MCW emission is selected, operating S602 will apply 1150 volts dc plate potential.)

(e) Operate the push-to-talk button on the microphone (applies 1150 volts dc plate potential) if VOICE emission has been selected or the key, S603, if CW or MCW emission has been selected.

#### IMPORTANT

When tuning the transmitter on the bench, a suitable 28 volt 35 ampere dc power source should be used. When tuning the transmitter in an airplane on the ground an external 28 volt dc power source capable of supplying 35 amperes should be used. If it is necessary to tune the transmitter using a primary voltage less than 28 volts, the loading of the final amplifier should be proportionately lower so that proper loading will be obtained when the primary voltage is 28 volts as when the airplane is in flight. The loading of the final amplifier given in the OPERATING ADJUSTMENTS section is based on 28 volts primary voltage. While checking the Autotune operation and setting, the EMISSION selector switch, S-110, should be placed in the



VOICE position. With S110 in the VOICE position, the Autotune system may be operated without applying primary power to the dynamotor. Placing S110 in the VOICE position operates the primary power contactor, K2102, and the voice relay, K104. The operation of relay K2102 applies power to the Autotune motor control circuits. This transmitter

uses tubes which require at least 30 seconds to warm up before operation. If conditions permit, it is recommended that the transmitter be maintained on "standby" in VOICE position key up, immediately before starting a flight and during the flight, thereby eliminating the 30 seconds warm up delay before any transmission can be made.

## SECTION III OPERATION

### 1. FUNCTION OF CONTROLS.

a. The high frequency control knobs are marked "A", "B", "C", "D", and "E", and are located along the lower part of the front panel. Refer to figure 3-1. These controls are preset for one channel by loosening locking bar in center of knob, rotating control either direction to desired setting, (but approaching final setting clockwise), then tightening the locking bar. The CHANNEL switch can then be turned to another channel, and after motor stops, all controls can be preset on another frequency. The Autotune controls are adjusted most satisfactorily by rotating the dials approximately one-eighth turn each side of the chosen dial reading in such a manner as to approach the final setting in a clockwise direction.

#### CAUTION

Always tighten locking bars before changing channels. Failure to do so will result in loss of dial settings.

b. Knob "A" is the coarse control of the high frequency oscillator. There are 12 high frequency positions, each marked with its frequency coverage in megacycles. Knob "A" also serves in Position 13 as a transfer switch to disconnect the high frequency oscillator and to connect the low frequency oscillator.

c. Knob "B" is the fine tuning control for high frequency operation. It consists of a main tuning knob, calibrated 0-100 which rotates 20 turns for each tuning range, and a small counter dial which counts turns of the large knob. The dial reading is the reading of the counter dial followed by the reading of the large knob. For example, if the counter dial is between 16 and 17, and the large knob is at 43, the dial would be read as 1643. Refer to figure 3-2. page 3-2.

d. Knob "C" is a coarse antenna tuning control which operates a tap switch. This tap switch changes inductance and capacity in various combinations for different frequencies to tune different antennas. In general, the dial settings increase with frequency. An interlock on this switch opens the keying relay to reduce arcs as the arm on the tap switch moves between points. This knob must be set accurately in position to permit the relay to operate.

e. Knob "D" controls fine tuning of the inductive portion of the antenna tuning network. Its scale is graduated 0-100 with maximum inductance at 0 and minimum inductance at 100.

f. Knob "E" controls the capacitive portion of the antenna tuning network. This knob has two scales, graduated 0-100 and 100-200.

Scale on Knob "E"	Capacity	Maximum Capacity at	Minimum Capacity at
100-200	Variable capacitor alone.	100	200
0-100	Variable capacitor plus fixed section to extend range.	0	100

#### WARNING

Do not leave the knob set in the blank space between scales and do not move Control E across the space between 100 and 200 or between 0 and 100 while the test switch, microphone button or key is closed. An internal switch will be damaged if this precaution is not followed.

g. Knob "F" is the coarse frequency control for either of the two low frequency oscillators. The positions of the knob on each oscillator are marked directly in frequency coverage.

h. Knob "G" is the fine frequency control for the low frequency oscillator. It rotates 20 turns to cover each range. The dial reading is the reading of the small turn counter, followed by the reading of the large knob. For example, if the turn counter is between 8 and 9, and the large knob is at 32, the dial reading for "G" is 832.

#### Note

It is necessary for Knob "A" to be set at 13 for low frequency operation.

i. The LOCAL-REMOTE switch transfers control of frequency and emission to the panel switches in LOCAL, or to the pilot's control box in REMOTE position.

j. The CHANNEL switch permits selection of the 10 high frequency and 1 low frequency preset

AN 08-30ART13-5

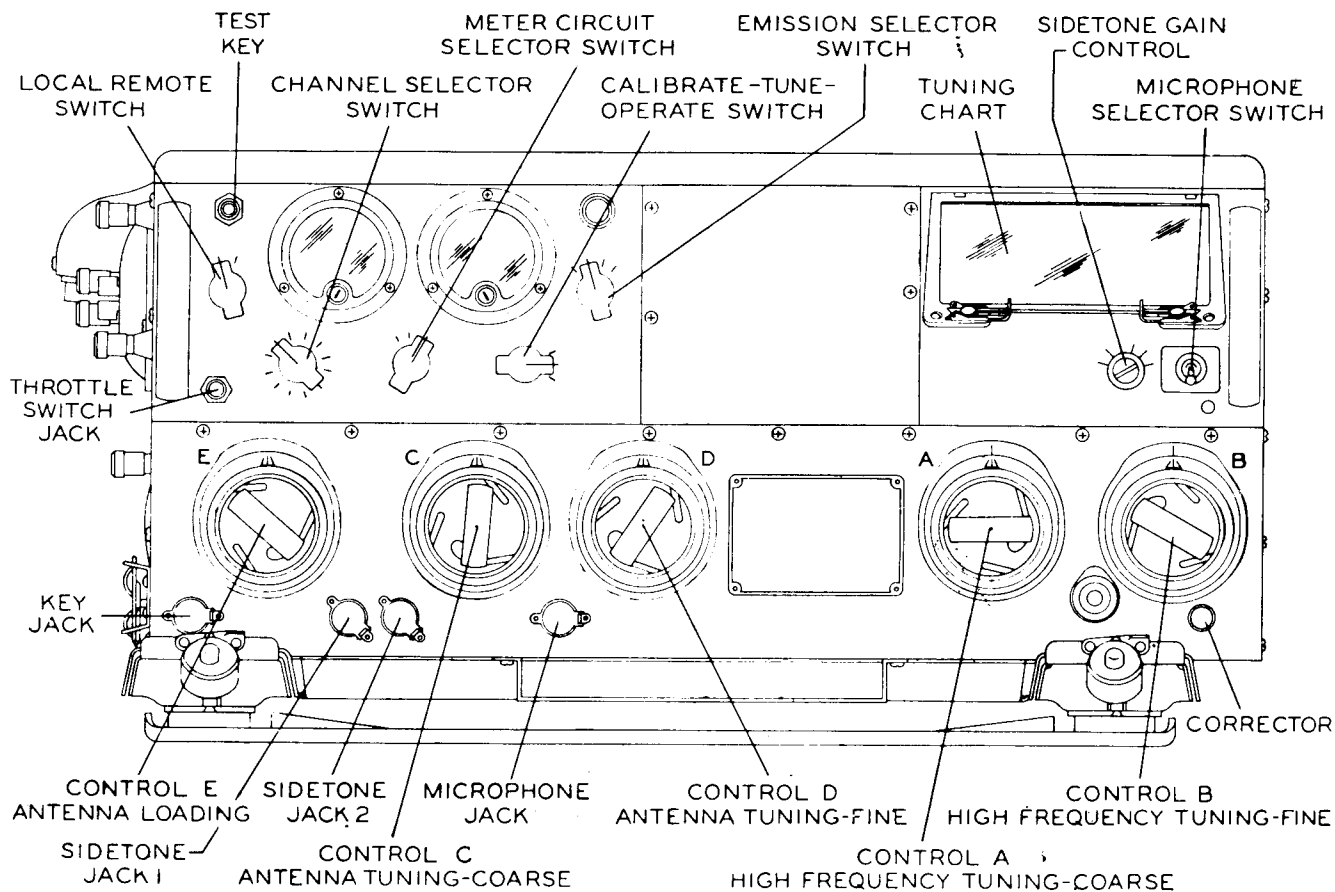

Figure 3-1. Type T-47/ART-13 Transmitter Controls

channels. In addition, a position marked MANUAL is provided where, if the Autotune system is allowed to operate, the knobs can be rotated freely without disturbing preset positions.

**CAUTION**

See that locking bars in Knobs "A", "B", "C", "D", and "E" are tight before changing channels.

k. The BATTERY - P.A. GRID - P.A. PLATE switch switches the right-hand meter to the circuits named. For tuning and normal operation, leave this switch in the P.A. PLATE position.

l. The CALIBRATE-TUNE-OPERATE switch turns on the calibrating oscillator and disables the power amplifier when in the CALIBRATE position. In TUNE position the equipment is operative at reduced power to prevent damage to the P.A. tube during preliminary tuning. IN OPERATE position the equipment operates at full power. This switch will normally be left in the OPERATE position.

m. The EMISSION switch controls type of emission, and also controls battery power. In the OFF position all power to the equipment is turned off.

n. A test key in the upper left-hand corner of the front panel can be used to operate the keying relay for tuning, etc.

o. The CARBON-DYNAMIC microphone switch and the sidetone output control are located behind the calibration chart, and are accessible by releasing the snap-slides on the chart and swinging it outward and upward. The sidetone OUTPUT control varies the sidetone output from one-half volt to 18 volts in 6 steps. Minimum output is at position 1, and maximum output at position 6.

p. A pressure operated switch in the dynamotor unit reduces P.A. plate voltage to reduce the danger of flashover at altitudes above approximately 25,000 feet. This function is automatic and requires no attention from the operator. The P.A. PLATE meter circuit is also switched at the same time so that its reading after the switch operates remains the same as before. A sharp change in reading of the antenna meter is the only indication that the pressure switch has operated.

**2. LOW FREQUENCY OSCILLATOR INSTALLATION**

a. A Type NX-128/ART-13 dummy unit containing a 28 ohm 10 watt filament substitute re-

sistor may be installed in the transmitter in place of a low frequency oscillator.

b. As supplied, the Model AN/ART-13 Transmitter will not operate below 2000 kc. If operation below 2000 kc is desired proceed as follows:

(1) Remove transmitter cover by inserting coin or screwdriver in holddown screws, making a half turn counterclockwise. Lift off cover.

(2) Remove 813 tube V104 by removing plate connector, inserting screwdriver through back of transmitter and using as a lever between tube base and socket, lift out tube.

(3) Using Phillips screwdriver remove two screws, exposed by removal of tube, that hold the back of the dummy unit.

(4) Loosen all screws along top edge of Autotune cover plate and remove the screws at bottom and sides of dummy LFO unit panel.

(5) Lift out dummy unit and insert either:

(a) Type O-16/ART-13 LFO for operation from 200 kc to 1500 kc or,

(b) Type O-17/ART-13A LFO for operation from 200 kc to 600 kc.

(6) Replace screws removed. Tighten all screws loosened.

(7) Replace tube by orienting base pin with slot in hole above socket and pressing down firmly until tube snaps solidly in socket. Replace plate cap connector.

(8) Attach LFO plate lead from multiplier unit to YFO unit using 5-16 wrench.

(9) The transmitter will now operate in the desired frequency range.

### 3. ADJUSTMENT OF TRANSMITTER ON DESIRED FREQUENCY USING INTERNAL CRYSTAL FREQUENCY CALIBRATOR (CFI).

#### a. GENERAL.

(1) Plug a pair of headphones into the SIDETONE 1 jack on the transmitter, or listen to sidetone through ICS. SIDETONE 2 cannot be used unless proper external connections have been made through remote jack J106. See Section II of this manual, paragraph 1., h., (4).

(2) Turn LOCAL-REMOTE switch to LOCAL.

(3) Find the desired frequency in calibration table 3-1. or 3-2.

(4) The main frequency controls ("B" for the high frequency range and "G" for the low frequency range) each rotate 20 turns to cover a tuning range. The dial reading given in the table is the number of turns indicated on the small

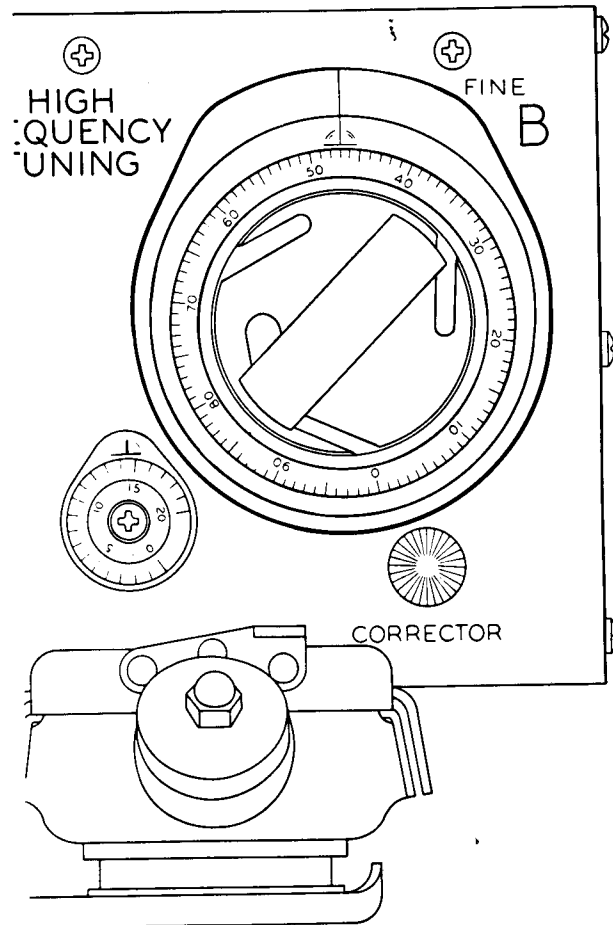

Figure 3-2. High Frequency Tuning Control

turn counter followed by the dial setting of the large knob. Thus, the dial reading shown in figure 3-2. is 1447.

#### b. FOR FREQUENCIES BETWEEN 200 AND 1500 KC.

(1) Turn CHANNEL switch to L. FREQ.

(2) Turn EMISSION switch to VOICE.

(3) After motor stops, if Knob "A" is not in position 13 loosen locking bar, rotate Knob "A" to 13, approaching the setting clockwise through at least one-eighth turn, and tighten locking bar.

(4) For the desired frequency set switch "F" to the position given in:

(a) Table 3-1 for the Type O-16/ART-13 Low Frequency Oscillator.

(b) Table 3-1A for the Type O-17/ART-13A Low Frequency Oscillator.

(5) Turn CALIBRATE - TUNE - OPERATE switch to CALIBRATE.

(6) Loosen dial lock and turn Knob "G" to the dial setting of the nearest crystal check point, shown in heavy type in the group of frequencies containing the desired frequency. Adjust Knob

"G" accurately for zero beat in the headphones.

(7) Leave Knob "G" at zero beat and adjust the CORRECTOR which moves the indicating mark until the dial reading at the mark is correct for the check point.

(8) Turn CALIBRATE - TUNE - OPERATE switch to TUNE.

(9) Turn Knob "G" to the dial setting given in table 3-1. for the desired frequency. Tighten dial lock.

(10) The low frequency oscillator is now set on the desired frequency. If it is desired to tune the output and antenna circuits of the transmitter into an antenna, proceed as described in paragraph 4. or 5.

c. FOR FREQUENCIES BETWEEN 2000 AND 18,100 KC.

(1) Turn CHANNEL switch to desired channel.

(2) After motor stops, loosen locking bar on Knob "A". Set this knob to the position shown in the table for the desired frequency, approaching the setting clockwise through at least one-eighth turn, and tighten the locking bar.

(3) Turn CALIBRATE - TUNE - OPERATE switch to CALIBRATE.

(4) Loosen locking bar in Knob "B". Turn Knob "B" to the dial setting of the nearest crystal check point, shown in heavy type in the group of frequencies in table 3-2. containing the desired frequency. Adjust Knob "B" accurately for zero beat in the headphones.

(5) Leave Knob "B" at zero beat and adjust the CORRECTOR which moves the indicating mark over "B" until the dial reading at the mark is correct for the check point.

(6) Turn CALIBRATE - TUNE - OPERATE switch to TUNE.

(7) Turn Knob "B" one-eighth turn each side of the dial setting given in the table for the desired frequency. Approach the given dial setting clockwise to the final position. Hold knob on setting and tighten locking bar.

(8) The high frequency oscillator is now set on the desired frequency. If it is desired to tune the output and antenna circuits to an antenna proceed as described in paragraph 5.

d. SELECTION OF FREQUENCIES BETWEEN THOSE GIVEN IN CALIBRATION TABLES. Calibration Table 3-1 gives dial settings at 2 kc intervals from 200 kc to 500 kc and 5 kc intervals from 500 kc to 1500 kc. Calibration Table 3-1A gives dial settings in 1 kc intervals from 200 kc to 600 kc and calibration Table 3-2 gives dial settings at 5 kc intervals from 2000 kc to 8000 kc also 10 kc intervals from 8000 kc to 18,100 kc. The transmitter can also be set to frequencies between those given in the tables by the following method:

(1) Find the difference between the desired frequency and the next lower frequency given in the table.

(2) Multiply this difference by the number given in parentheses at the right of the column of figures containing the next lower frequency.

(3) Add the product thus obtained to the dial setting given in the table for the next lower frequency. The result is the dial setting for the desired frequency.

(4) Example: It is desired to work on 9653 kilocycles. The next lower frequency given in the table is 9650, and the difference is 3. The number in parentheses at the right of the column is 0.8. Multiplying 3 by 0.8 gives 2.4. Adding 2.4 to 9650, which is the dial setting for 9650, gives 9652.4 as the dial setting for 9653 kilocycles.

Frequency 200 to 750 kc

LFO 0-16/ART-13

TABLE 3-1. LF OSCILLATOR CALIBRATION DATA (200 Kc. to 1500 Kc.)

Freq.	A	F	G	Freq.	A	F	G	Freq.	A	F	G	Freq.	A	F	G
<b>200</b>	<b>13</b>	<b>1</b>	<b>393</b>	<b>300</b>	<b>13</b>	<b>2</b>	<b>1114</b>	<b>400</b>	<b>13</b>	<b>3</b>	<b>1090</b>	<b>500</b>	<b>13</b>	<b>4</b>	<b>518</b>
202	13	1	469	302	13	2	1153	402	13	3	1120	505	13	4	565
204	13	1	540	304	13	2	1192	404	13	3	1148	510	13	4	609
206	13	1	609	306	13	2	1229	406	13	3	1177	515	13	4	654
208	13	1	676	308	13	2	1266	408	13	3	1205	520	13	4	697
210	13	1	739	310	13	2	1302	410	13	3	1233				(9 divisions per kc)
212	13	1	801	312	13	2	1338	412	13	3	1260	525	13	4	739
214	13	1	861	314	13	2	1373	414	13	3	1288	530	13	4	781
216	13	1	919	316	13	2	1407	416	13	3	1314	535	13	4	821
218	13	1	976	318	13	2	1442	418	13	3	1341	540	13	4	862
220	13	1	1030	320	13	2	1476	420	13	3	1368	545	13	4	901
222	13	1	1084	322	13	2	1508	422	13	3	1394	<b>550</b>	<b>13</b>	<b>4</b>	<b>940</b>
224	13	1	1136	324	13	2	1542	424	13	3	1419	555	13	4	978
												560	13	3	1016
												565	13	4	1053
226	13	1	1187	326	13	2	1574	426	13	3	1445	570	13	4	1090
228	13	1	1237	328	13	2	1606	428	13	3	1470				
230	13	1	1286	330	13	2	1638	430	13	3	1495				
232	13	1	1334	332	13	2	1670	432	13	3	1519	575	13	4	1127
234	13	1	1381	334	13	2	1701					580	13	4	1163
236	13	1	1426	336	13	2	1732	434	13	3	1544	585	13	4	1198
238	13	1	1472	338	13	2	1763	436	13	3	1569	590	13	4	1234
240	13	1	1515	340	13	2	1793	438	13	3	1593	595	13	4	1270
242	13	1	1560	342	13	2	1823	440	13	3	1616	<b>600</b>	<b>13</b>	<b>4</b>	<b>1304</b>
244	13	1	1603	344	13	2	1854	442	13	3	1641	605	13	4	1340
				346	13	2	1883	444	13	3	1665	610	13	4	1375
246	13	1	1646	348	13	2	1912	446	13	3	1688	615	13	4	1408
248	13	1	1688	<b>350</b>	<b>13</b>	<b>2</b>	<b>1942</b>	448	13	3	1710	620	13	4	1444
<b>250</b>	<b>13</b>	<b>1</b>	<b>1729</b>	352	13	2	1971	450	<b>13</b>	<b>3</b>	<b>1734</b>	625	13	4	1479
252	13	1	1770	354	13	2	2000	452	13	3	1757				
254	13	1	1810	356	13	2	2028	454	13	3	1780	630	13	4	1512
256	13	1	1851					456	13	3	1802	635	13	4	1548
258	13	1	1890	<b>350</b>	<b>13</b>	<b>3</b>	<b>154</b>	458	13	3	1825	640	13	4	1584
260	13	1	1929	352	13	3	205	460	13	3	1847	645	13	4	1618
262	13	1	1968	354	13	3	255	462	13	3	1870	<b>650</b>	<b>13</b>	<b>4</b>	<b>1655</b>
				356	13	3	302	464	13	3	1892	655	13	4	1691
262	13	2	175	358	13	3	347	466	13	3	1913	660	13	4	1728
264	13	2	242	360	13	3	392	468	13	3	1936	665	13	4	1766
266	13	2	305	362	13	3	434	470	13	3	1958	670	13	4	1804
268	13	2	366	364	13	3	476	472	13	3	1980				
270	13	2	423	366	13	3	515	474	13	3	2001	675	13	4	1845
272	13	2	480	368	13	3	555	476	13	3	2022	680	13	4	1886
274	13	2	533	370	13	3	593					685	13	4	1928
276	13	2	585	372	13	3	631	468	13	4	191	690	13	4	1976
278	13	2	635	374	13	3	668	470	13	4	213	695	13	4	2023
280	13	2	684					472	13	4	235				
282	13	2	731	376	13	3	704	474	13	4	257	695	13	5	156
284	13	2	778	378	13	3	739	476	13	4	279	<b>700</b>	<b>13</b>	<b>5</b>	<b>195</b>
286	13	2	823	380	13	3	774	478	13	4	300	705	13	5	231
288	13	2	868	382	13	3	808	480	13	4	321	710	13	5	269
290	13	2	911	384	13	3	841	482	13	4	342	715	13	5	303
292	13	2	953	386	13	3	874	484	13	4	363	720	13	5	338
294	13	2	995	388	13	3	906	486	13	4	383	725	13	5	373
296	13	2	1035	390	13	3	938	488	13	4	402				
298	13	2	1075	392	13	3	970	490	13	4	422	730	13	5	406
<b>300</b>	<b>13</b>	<b>2</b>	<b>1114</b>	394	13	3	1000	492	13	4	442	735	13	5	438
				396	13	3	1030	494	13	4	462	740	13	5	471
				398	13	3	1061	496	13	4	481	745	13	5	502
				<b>400</b>	<b>13</b>	<b>3</b>	<b>1090</b>	498	13	3	499	<b>750</b>	<b>13</b>	<b>5</b>	<b>553</b>
								<b>500</b>	<b>13</b>	<b>4</b>	<b>518</b>				

Use nearest check point shown in heavy type.

Revised 1 June 1952

## Frequency 750 to 1500 kilocycles

TABLE 3-1. (Continued)

Freq.	A	F	G	Freq.	A	F	G	Freq.	A	F	G
<b>750</b>	<b>13</b>	<b>5</b>	<b>533</b>	<b>1000</b>	<b>13</b>	<b>5</b>	<b>1795</b>	<b>1250</b>	<b>13</b>	<b>6</b>	<b>1016</b>
755	13	5	565	1005	13	5	1822	1255	13	6	1032
760	13	5	594	1010	13	5	1850	1260	13	6	1050
765	13	5	624	1015	13	5	1878	1265	13	6	1067
770	13	5	654	1020	13	5	1905	<b>1267</b>	<b>13</b>	<b>6</b>	<b>1073</b>
			(6 div. per kc)	1025	13	5	1935	1270	13	6	1084
775	13	5	683	1030	13	5	1966	1275	13	6	1100
780	13	5	711	1035	13	5	1998				(3.4 div. per kc)
785	13	5	739					1280	13	6	1116
790	13	5	768	1035	13	6	145	1285	13	6	1132
795	13	5	795	1040	13	6	171	1290	13	6	1149
<b>800</b>	<b>13</b>	<b>5</b>	<b>821</b>	1045	13	6	196	1295	13	6	1166
805	13	5	849	<b>1050</b>	<b>13</b>	<b>6</b>	<b>219</b>	<b>1300</b>	<b>13</b>	<b>6</b>	<b>1182</b>
810	13	5	876	1055	13	6	244	1305	13	6	1198
815	13	5	901	1060	13	6	270	1310	13	6	1214
820	13	5	927	1065	13	6	293	1315	13	6	1230
825	13	5	953	1070	13	6	315	1320	13	6	1246
			(5.4 divisions per kc)					1325	13	6	1262
830	13	5	979	1075	13	6	338				
835	13	5	1004	1080	13	6	363				
840	13	5	1029	1085	13	6	385	1330	13	6	1278
845	13	5	1054	1090	13	6	407	1335	13	6	1294
<b>850</b>	<b>13</b>	<b>5</b>	<b>1079</b>	1095	13	6	428	1340	13	6	1309
855	13	5	1103	<b>1100</b>	<b>13</b>	<b>6</b>	<b>451</b>	1345	13	6	1325
860	13	5	1127	1105	13	6	473	<b>1350</b>	<b>13</b>	<b>6</b>	<b>1341</b>
865	13	5	1152	1110	13	6	493	1355	13	6	1358
870	13	5	1176	1115	13	6	514	1360	13	6	1374
875	13	5	1199	1120	13	6	534	1365	13	6	1389
880	13	5	1223					1370	13	6	1404
			(4.9 divisions per kc)	1125	13	6	556	1375	13	6	1419
885	13	5	1247	1130	13	6	576				
890	13	5	1270	1135	13	6	596	1380	13	6	1436
895	13	5	1294	1140	13	6	615	1385	13	6	1452
<b>900</b>	<b>13</b>	<b>5</b>	<b>1317</b>	1145	13	6	635	1390	13	6	1468
905	13	5	1341	<b>1150</b>	<b>13</b>	<b>6</b>	<b>656</b>	1395	13	6	1484
910	13	5	1364	1155	13	6	675	<b>1400</b>	<b>13</b>	<b>6</b>	<b>1499</b>
915	13	5	1387	1160	13	6	694	1405	13	6	1514
920	13	5	1410	1165	13	6	712	1410	13	6	1530
			(4.7 divisions per kc)	1170	13	6	731	1415	13	6	1547
925	13	5	1433	1175	13	6	751	1420	13	6	1563
930	13	5	1457					1425	13	6	1580
935	13	5	1480	1180	13	6	770				
940	13	5	1503	1185	13	6	788	1430	13	6	1595
945	13	5	1526	1190	13	6	806	1435	13	6	1611
950	13	5	1550	1195	13	6	823	1440	13	6	1627
955	13	5	1574	<b>1200</b>	<b>13</b>	<b>6</b>	<b>842</b>	1445	13	6	1644
960	13	5	1597	1205	13	6	860	<b>1450</b>	<b>13</b>	<b>6</b>	<b>1661</b>
965	13	5	1621	1210	13	6	878	1455	13	6	1678
970	13	5	1645	1215	13	6	895	1460	13	6	1694
			(4.7 divisions per kc)	1220	13	6	913	1465	13	6	1710
975	13	5	1670	1225	13	6	930	1470	13	6	1727
980	13	5	1694					1475	13	6	1744
985	13	5	1718	1230	13	6	948				
990	13	5	1744	1235	13	6	966	1480	13	6	1763
995	13	5	1770	1240	13	6	983	1485	13	6	1780
<b>1000</b>	<b>13</b>	<b>5</b>	<b>1795</b>	1245	13	6	999	1490	13	6	1797
			(5 divisions per kc)	<b>1250</b>	<b>13</b>	<b>6</b>	<b>1016</b>	1495	13	6	1813
			(3.4 div. per kc)					<b>1500</b>	<b>13</b>	<b>6</b>	<b>1832</b>
											(3.5 div. per kc)

Use nearest check point shown in heavy type.

Section III  
Paragraph 3

AN 08-30ART13-5

LFO 0-17/ART-13A

Frequency 200 to 600 kc

TABLE 3-1A. LF OSCILLATOR CALIBRATION DATA (200 Kc to 600 Kc.)

Freq.	A	F	G	Freq.	A	F	G	Freq.	A	F	G	Freq.	A	F	G
<b>200</b>	<b>13</b>	<b>1</b>	<b>189.2</b>	<b>250</b>	<b>13</b>	<b>1</b>	<b>1216.8</b>	<b>300</b>	<b>13</b>	<b>2</b>	<b>350.8</b>	<b>350</b>	<b>13</b>	<b>2</b>	<b>1055.0</b>
201	13	1	212.0	251	13	1	1237.1	301	13	2	365.7	351	13	2	1069.1
202	13	1	234.8	252	13	11	1257.4	302	13	2	379.4	352	13	2	1083.2
203	13	1	256.8	253	13	1	1277.8	303	13	2	394.5	353	13	2	1097.3
204	13	1	278.0	254	13	1	1298.1	304	13	2	408.7	354	13	2	1111.4
205	13	1	299.8	255	13	1	1318.4	305	13	2	423.5	355	13	2	1125.5
206	13	1	321.3	256	13	1	1338.7	306	13	2	438.7	356	13	2	1139.6
207	13	1	342.8	257	13	1	1359.0	307	13	2	452.0	357	13	2	1153.7
208	13	1	363.6	258	13	1	1379.4	308	13	2	466.0	358	13	2	1167.8
209	13	1	384.3	259	13	1	1399.7	309	13	2	480.0	359	13	2	1181.9
210	13	1	405.0	260	13	1	1420.0	310	13	2	494.0	360	13	2	1196.0
211	13	1	425.3	261	13	1	1440.0	311	13	2	509.2	361	13	2	1210.1
212	13	1	445.6	262	13	1	1460.9	312	13	2	522.4	362	13	2	1224.3
213	13	1	466.5	263	13	1	1481.4	313	13	2	536.6	363	13	2	1238.4
214	13	1	486.7	264	13	1	1501.8	314	13	2	550.6	364	13	2	1252.6
215	13	1	508.1	265	13	1	1522.2	315	13	2	564.4	365	13	2	1266.7
216	13	1	527.5	266	13	1	1542.7	316	13	2	578.4	366	13	2	1280.9
217	13	1	548.0	267	13	1	1563.1	317	13	2	592.2	367	13	2	1295.0
218	13	1	568.0	268	13	1	1583.6	318	13	2	606.2	368	13	2	1309.2
219	13	1	588.0	269	13	1	1604.0	319	13	2	620.2	369	13	2	1323.3
220	13	1	608.0	270	13	1	1624.5	320	13	2	634.2	370	13	2	1337.5
221	13	1	628.1	271	13	1	1645.6	321	13	2	648.1	371	13	2	1351.5
222	13	1	648.2	272	13	1	1666.0	322	13	2	662.0	372	13	2	1365.6
223	13	1	668.2	273	13	1	1686.5	323	13	2	675.8	373	13	2	1379.6
224	13	1	688.3	274	13	1	1707.2	324	13	2	689.7	374	13	2	1393.6
<b>225</b>	<b>13</b>	<b>1</b>	<b>708.4</b>	<b>275</b>	<b>13</b>	<b>1</b>	<b>1728.8</b>	<b>325</b>	<b>13</b>	<b>2</b>	<b>703.6</b>	<b>375</b>	<b>13</b>	<b>2</b>	<b>1407.6</b>
226	13	1	728.5	276	13	1	1750.0	326	13	2	717.5	376	13	2	1421.7
227	13	1	748.6	277	13	1	1771.0	327	13	2	731.4	377	13	2	1435.7
228	13	1	768.6	278	13	1	1792.0	328	13	2	745.2	378	13	2	1449.7
229	13	1	788.7	279	13	1	1814.0	329	13	2	759.1	379	13	2	1463.7
230	13	1	808.8	280	13	1	1836.0	330	13	2	773.0	380	13	2	1477.8
231	13	1	829.2	281	13	1	1858.0	331	13	2	786.4	381	13	2	1492.0
232	13	1	849.5	282	13	1	1880.0	332	13	2	801.0	382	13	2	1506.2
233	13	1	869.9	283	13	11	1902.2	333	13	2	815.0	383	13	2	1520.3
234	13	1	890.2	284	13	1	1925.2	334	13	2	829.0	384	13	2	1534.5
235	13	1	910.6	285	13	1	1948.5	335	13	2	843.0	385	13	2	1548.7
236	13	1	931.0	285	13	2	118.8	336	13	2	857.0	386	13	2	1562.9
237	13	1	951.3	286	13	2	135.7	337	13	2	871.0	387	13	2	1577.1
238	13	1	971.7	287	13	2	152.2	338	13	2	885.0	388	13	2	1591.2
239	13	1	992.0	288	13	2	168.2	339	13	2	899.0	389	13	2	1605.4
240	13	1	1012.4	289	13	2	184.2	340	13	2	913.0	390	13	2	1619.6
241	13	1	1032.8	290	13	2	200.2	341	13	2	927.2	391	13	2	1634.1
242	13	1	1053.3	291	13	2	215.5	342	13	2	941.4	392	13	2	1648.6
243	13	1	1073.7	292	13	2	231.0	343	13	2	955.6	393	13	2	1663.2
244	13	1	1094.2	293	13	2	246.8	344	13	2	969.8	394	13	2	1677.7
245	13	1	1114.6	294	13	2	261.8	345	13	2	984.0	395	13	2	1692.2
246	13	1	1135.0	295	13	2	276.5	346	13	2	998.2	396	13	2	1706.7
247	13	1	1155.5	296	13	2	291.4	347	13	2	1012.4	397	13	2	1721.2
248	13	1	1175.9	297	13	2	306.5	348	13	2	1026.6	398	13	2	1835.7
249	13	1	1196.4	298	13	2	321.5	349	13	2	1040.8	399	13	2	1750.3
<b>250</b>	<b>13</b>	<b>1</b>	<b>1216.8</b>	299	13	2	336.2	<b>350</b>	<b>13</b>	<b>2</b>	<b>1055.0</b>	<b>400</b>	<b>13</b>	<b>2</b>	<b>1764.8</b>



## Frequency 200 to 600 kc

TABLE 3-1A. (Continued)

Freq.	A	F	G	Freq.	A	F	G	Freq.	A	F	G	Freq.	A	F	G
400	13	2	1764.8	450	13	3	489.0	500	13	3	971.8	550	13	3	1458.2
401	13	2	1779.0	451	13	33	498.7	501	13	3	981.6	551	13	3	1467.9
402	13	2	1793.7	452	13	3	508.4	502	13	3	991.3	552	13	3	1477.7
403	13	2	1809.0	453	13	3	518.0	503	13	3	1001.1	553	13	3	1487.4
404	13	2	1824.0	454	13	3	527.7	504	13	3	1010.9	554	13	3	1497.1
405	13	2	1839.4	455	13	3	537.4	505	13	3	1020.6	555	13	3	1506.9
406	13	2	1854.4	456	13	3	547.1	506	13	3	1030.4	556	13	3	1516.6
407	13	2	1869.4	457	13	3	556.8	507	13	3	1040.2	557	13	3	1526.3
408	13	2	1885.0	458	13	3	566.4	508	13	3	1050.0	558	13	3	1536.1
409	13	2	1900.2	459	13	3	576.1	509	13	3	1059.7	559	13	3	1545.9
410	13	2	1916.2	460	13	3	585.8	510	13	3	1069.5	560	13	3	1555.6
411	13	2	1932.2	461	13	3	595.4	511	13	3	1079.2	561	13	3	1565.4
412	13	2	1948.2	462	13	3	605.0	512	13	3	1089.0	562	13	3	1575.2
413	13	2	1964.4	463	13	3	614.6	513	13	3	1098.8	563	13	3	1585.1
414	13	2	1980.3	464	13	3	624.2	514	13	3	1108.5	564	13	3	1594.9
415	13	2	1997.0	465	13	3	633.8	515	13	3	1118.2	565	13	3	1604.7
416	13	3	127.2	466	13	3	643.4	516	13	3	1128.0	566	13	3	1614.5
417	13	3	138.6	467	13	3	653.0	517	13	3	1137.7	567	13	3	1624.3
418	13	3	150.2	468	13	3	662.6	518	13	3	1147.5	568	13	3	1634.3
419	13	3	161.3	469	13	3	672.2	519	13	3	1157.3	569	13	3	1644.0
420	13	3	172.2	470	13	3	681.8	520	13	3	1167.0	570	13	3	1653.8
421	13	3	183.0	471	13	3	691.4	521	13	3	1176.8	571	13	3	1663.8
422	13	3	193.8	472	13	3	701.0	522	13	3	1186.5	572	13	3	1673.2
423	13	3	205.0	473	13	3	710.5	523	13	3	1196.2	573	13	3	1682.0
424	13	3	215.6	474	13	3	720.1	524	13	3	1206.0	574	13	3	1692.8
425	13	3	226.6	475	13	3	729.7	525	13	3	1215.7	575	13	3	1703.0
426	13	3	237.2	476	13	3	739.3	526	13	3	1225.5	576	13	3	1713.0
427	13	3	247.7	477	13	3	748.9	527	13	3	1235.2	577	13	3	1723.0
428	13	3	258.2	478	13	3	758.4	528	13	3	1245.0	578	13	3	1733.4
429	13	3	268.4	479	13	3	768.0	529	13	3	1254.7	579	13	3	1743.4
430	13	3	277.7	480	13	3	777.6	530	13	3	1264.5	580	13	3	1753.4
431	13	3	289.2	481	13	3	787.3	531	13	3	1274.2	581	13	3	1763.4
432	13	3	299.6	482	13	3	796.9	532	13	3	1283.9	582	13	3	1773.2
433	13	3	310.2	483	13	3	806.6	533	13	3	1293.6	583	13	3	1783.2
434	13	3	320.4	484	13	3	816.2	534	13	3	1303.2	584	13	3	1793.8
435	13	3	330.4	485	13	3	825.9	535	13	3	1312.9	585	13	3	1804.0
436	13	3	340.6	486	13	3	835.6	536	13	3	1322.6	586	13	3	1814.4
437	13	3	350.8	487	13	3	845.2	537	13	3	1332.3	587	13	3	1824.8
438	13	3	360.8	488	13	3	854.9	538	13	3	1342.0	588	13	3	1835.2
439	13	3	370.6	489	13	3	864.5	539	13	3	1351.7	589	13	3	1845.9
440	13	3	380.4	490	13	3	874.2	540	13	3	1361.4	590	13	3	1856.2
441	13	3	390.4	491	13	3	884.0	541	13	3	1371.1	591	13	3	1866.4
442	13	3	400.3	492	13	3	893.7	542	13	3	1380.8	592	13	3	1877.0
443	13	3	410.1	493	13	3	903.5	543	13	3	1390.4	593	13	3	1887.5
444	13	3	420.0	494	13	3	913.2	544	13	3	1400.1	594	13	3	1898.0
445	13	3	429.8	495	13	3	923.3	545	13	3	1409.8	595	13	3	1909.0
446	13	3	439.7	496	13	3	932.8	546	13	3	1419.5	596	13	3	1920.0
447	13	3	449.6	497	13	3	942.5	547	13	3	1429.2	597	13	3	1931.0
448	13	3	459.4	498	13	3	952.3	548	13	3	1438.8	598	13	3	1942.0
449	13	3	469.3	499	13	3	962.0	549	13	3	1448.5	599	13	3	1953.0
450	13	3	479.1	500	13	3	971.8	550	13	3	1458.2	600	13	3	1964.0

Frequency 2000 to 3000 kilocycles

TABLE 3-2. HF OSCILLATOR CALIBRATION DATA (2000 Kc. to 18,100 Kc.)

Freq.	A	B	Freq.	A	B	Freq.	A	B	Freq.	A	B
<b>2000</b>	<b>1</b>	<b>100</b>	2250	1	1027	<b>2500</b>	<b>2</b>	<b>366</b>	2750	2	1133
2005	1	119	2255	1	1046	2505	2	381	2755	2	1148
2010	1	138	2260	1	1064	2510	2	397	2760	2	1163
2015	1	156	2265	1	1083	2515	2	412	2765	2	1179
2020	1	174	2270	1	1101	2520	2	427	2770	2	1194
2025	1	193	2275	1	1119	2525	2	443	2775	2	1209
2030	1	211	2280	1	1138	2530	2	458	2780	2	1224
2035	1	230	2285	1	1156	2535	2	474	2785	2	1239
2040	1	248	2290	1	1174	2540	2	489	2790	2	1254
2045	1	267	2295	1	1193	2545	2	505	2795	2	1270
2050	1	285	<b>2300</b>	<b>1</b>	<b>1211</b>	2550	2	520	<b>2800</b>	<b>2</b>	<b>1285</b>
			2305	1	1229				2805	2	1300
2055	1	303	2310	1	1247	2555	2	535	2810	2	1315
2060	1	322	2315	1	1265	2560	2	551	2815	2	1330
2065	1	340	2320	1	1284	2565	2	567	2820	2	1345
2070	1	359	2325	1	1302	2570	2	590	2825	2	1361
2075	1	377	2330	1	1321	2575	2	597	2830	2	1376
2080	1	396	2335	1	1339	2580	2	613	2835	2	1391
2085	1	415	2340	1	1357	2585	2	628	2840	2	1406
2090	1	433	2345	1	1376	2590	2	644	2845	2	1421
2095	1	452	2350	1	1394	2595	2	659	2850	2	1436
<b>2100</b>	<b>1</b>	<b>470</b>				<b>2600</b>	<b>2</b>	<b>674</b>	2855	2	1452
2105	1	489	2355	1	1412	2605	2	690	2860	2	1469
2110	1	508	2360	1	1430	2610	2	705	2865	2	1482
2115	1	526	2365	1	1449	2615	2	721	2870	2	1498
2120	1	545	2370	1	1468	2620	2	736	2875	2	1513
2125	1	564	2375	1	1486	2625	2	756	2880	2	1528
2130	1	582	2380	1	1504	2630	2	767	2885	2	1544
2135	1	601	2385	1	1523	2635	2	782	2890	2	1559
2140	1	620	2390	1	1541	2640	2	797	2895	2	1574
2145	1	638	2395	1	1560	2645	2	813	<b>2900</b>	<b>2</b>	<b>1590</b>
2150	1	657	<b>2400</b>	<b>1</b>	<b>1578</b>	2650	2	828	2905	2	1605
									2910	2	1621
2155	1	675	<b>2400</b>	<b>2</b>	<b>060</b>	2655	2	844	2915	2	1636
2160	1	693	2405	2	076	2660	2	859	2920	2	1653
2165	1	713	2410	2	091	2665	2	874	2925	2	1668
2170	1	732	2415	2	106	2670	2	890	2930	2	1683
2175	1	750	2420	2	121	2675	2	905	2935	2	1699
2180	1	769	2425	2	137	2680	2	920	2940	2	1715
2185	1	787	2430	2	152				2945	2	1731
2190	1	806	2435	2	168				2950	2	1749
2195	1	824	2440	2	183	2685	2	935			
<b>2200</b>	<b>1</b>	<b>843</b>	2445	2	198	2690	2	951			
2205	1	862	2450	2	213	2695	2	966	2955	2	1763
2210	1	880				<b>2700</b>	<b>2</b>	<b>981</b>	2960	2	1779
2215	1	898	2455	2	228	2705	2	996	2965	2	1795
2220	1	917	2460	2	243	2710	2	1012	2970	2	1811
2225	1	935	2465	2	259	2715	2	1027	2975	2	1827
2230	1	954	2470	2	274	2720	2	1042	2980	2	1843
2235	1	972	2475	2	290	2725	2	1057	2985	2	1860
2240	1	991	2480	2	305	2730	2	1073	2990	2	1877
2245	1	1009	2485	2	320	2735	2	1088	2995	2	1893
2250	1	1027	2490	2	335	2740	2	1103	<b>3000</b>	<b>2</b>	<b>1910</b>
			2495	2	351	2745	2	1118			
			<b>2500</b>	<b>2</b>	<b>366</b>	2750	2	1133			

Use nearest check point shown in heavy type.

Frequency 3000 to 4000 kilocycles

TABLE 3-2. (Continued)

Freq.	A	B	Freq.	A	B	Freq.	A	B	Freq.	A	B
<b>3000</b>	<b>3</b>	<b>100</b>	3250	3	719	3500	3	1333	<b>3750</b>	<b>4</b>	<b>366</b>
3005	3	113	3255	3	731	3505	3	1345	3755	4	376
3010	3	126	3260	3	743	3510	3	1357	3760	4	386
3015	3	138	3265	3	755	3515	3	1369	3765	4	397
3020	3	150	3270	3	769	3520	3	1381	3770	4	407
3025	3	162	3275	3	781	3525	3	1394	3775	4	417
3030	3	174	3280	3	793				3780	4	427
3035	3	186	3285	3	806	3530	3	1406	3785	4	437
3040	3	198	3290	3	818	3535	3	1418	3790	4	447
3045	3	211	3295	3	830	3540	3	1430	3795	4	458
3050	3	223	<b>3300</b>	<b>3</b>	<b>843</b>	3545	3	1443	3800	4	469
3055	3	235	3305	3	855	3550	3	1456	3805	4	479
3060	3	248	3310	3	867	3555	3	1468	3810	4	489
3065	3	260	3315	3	880	3560	3	1480	3815	4	499
3070	3	272	3320	3	892	3565	3	1492	3820	4	509
3075	3	285	3325	3	904	3570	3	1504	3825	4	520
			3330	3	917	3575	3	1516			
3080	3	297	3335	3	929	3580	3	1528	3830	4	530
3085	3	309	3340	3	941	3585	3	1541	3835	4	540
3090	3	322	3345	3	954	3590	3	1553	3840	4	551
3095	3	334	3350	3	966	3595	3	1565	3845	4	561
3100	3	346				<b>3600</b>	<b>3</b>	<b>1578</b>	3850	4	571
3105	3	359	3355	3	978				3855	4	582
3110	3	371	3360	3	991	<b>3600</b>	<b>4</b>	<b>060</b>	3860	4	592
3115	3	383	3365	3	1003	3605	4	070	3865	4	602
3120	3	396	3370	3	1015	3610	4	080	3870	4	613
3125	3	408	3375	3	1027	3615	4	091	3875	4	623
3130	3	420				3620	4	101	3880	4	633
3135	3	433	3380	3	1039	3625	4	116	3885	4	644
3140	3	445	3385	3	1051	3630	4	121	3890	4	654
3145	3	457	3390	3	1064	3635	4	131	3895	4	664
<b>3150</b>	<b>3</b>	<b>470</b>	3395	3	1076	3640	4	141	<b>3900</b>	<b>4</b>	<b>674</b>
3155	3	483	3400	3	1088	3645	4	152	3905	4	684
3160	3	496	3405	3	1101	3650	4	162	3910	4	694
3165	3	508	3410	3	1113	3655	4	172	3915	4	705
3170	3	520	3415	3	1125	3660	4	183	3920	4	715
3175	3	532	3420	3	1138	3665	4	193	3925	4	725
			3425	3	1150	3670	4	203	3930	4	736
3180	3	545	3430	3	1162	3675	4	213	3935	4	746
3185	3	557	3435	3	1174				3940	4	756
3190	3	569	3440	3	1186	3680	4	223	3945	4	767
3195	3	582	3445	3	1198	3685	4	233	3950	4	777
3200	3	594	<b>3450</b>	<b>3</b>	<b>1211</b>	3690	4	243			
3205	3	606	3455	3	1223	3695	4	253	3955	4	787
3210	3	620	3460	3	1235	3700	4	264	3960	4	797
3215	3	632	3465	3	1247	3705	4	275	3965	4	807
3220	3	644	3470	3	1259	3710	4	285	3970	4	817
3225	3	657	3475	3	1271	3715	4	295	3975	4	828
			3480	3	1284	3720	4	305	3980	4	838
3230	3	669	3485	3	1296	3725	4	315	3985	4	848
3235	3	681	3490	3	1308	3730	4	325	3990	4	859
3240	3	693	3495	3	1321	3735	4	335	3995	4	869
3245	3	706	3500	3	1333	3740	4	345	<b>4000</b>	<b>4</b>	<b>879</b>
3250	3	719				3745	4	355			
						<b>3750</b>	<b>4</b>	<b>366</b>			

Use nearest check point shown in heavy type.

Frequency 4000 to 5000 kilocycles

TABLE 3-2. (Continued)

Freq.	A	B	Freq.	A	B	Freq.	A	B	Freq.	A	B
<b>4000</b>	<b>5</b>	<b>100</b>	<b>4200</b>	<b>5</b>	<b>470</b>	4500	5	1027	4750	5	1486
4005	5	109	4250	5	564	4505	5	1036	4755	5	1495
4010	5	119	4255	5	573	4510	5	1046	4760	5	1504
4015	5	128	4260	5	582	4515	5	1055	4765	5	1513
4020	5	138	4265	5	591	4520	5	1064	4770	5	1523
4025	5	147	4270	5	601	4525	5	1073	4775	5	1532
4030	5	156	4275	5	610	4530	5	1083	4780	5	1541
4035	6	165	4280	5	620	4535	5	1092	4785	5	1550
4040	5	174	4285	5	629	4540	5	1101	4790	5	1560
4045	5	183	4290	5	638	4545	5	1110	4795	5	1569
4050	5	193	4295	5	647	4550	5	1119	<b>4800</b>	<b>5</b>	<b>1578</b>
4055	5	202	4300	5	657	4555	5	1128			
4060	5	211				4560	5	1138	<b>4800</b>	<b>6</b>	<b>060</b>
4065	5	220	4305	5	666	4565	5	1147	4805	6	068
4070	5	230	4310	5	675	4570	5	1156	4810	6	076
4075	5	239	4315	5	684	4575	5	1165	4815	6	084
4080	5	248	4320	5	693	4580	5	1174	4820	6	091
4085	5	257	4325	5	702	4585	5	1183	4825	6	099
4090	5	267	4330	5	713	4590	5	1193	4830	6	106
4095	5	276	4335	5	722	4595	5	1202	4835	6	114
4100	5	285	4340	5	732	<b>4600</b>	<b>5</b>	<b>1211</b>	4840	6	121
			4345	5	741	4605	5	1220	4845	6	129
4105	5	293	4350	5	750	4610	5	1229	4850	6	137
4110	5	303	4355	5	759	4615	5	1338	4855	6	145
4115	5	312	4360	5	769	4620	5	1247	4860	6	152
4120	5	322	4365	5	778	4625	5	1256	4865	6	160
4125	5	331	4370	5	787	4630	5	1266	4870	6	168
4130	5	340	4375	5	796	4635	5	1275	4875	6	176
4135	5	349	4380	5	806	4640	5	1284	4880	6	183
4140	5	359	4385	5	815	4645	5	1293	4885	6	191
4145	5	368	4390	5	824	4650	5	1302	4890	6	198
4150	5	377	4395	5	833	4655	5	1311	4895	6	206
4155	5	386	<b>4400</b>	<b>5</b>	<b>843</b>	4660	5	1321	4900	6	213
4160	5	396	4405	5	852	4665	5	1330			
4165	5	405	4410	5	862	4670	5	1339	4905	6	221
4170	5	415	4415	5	871	4675	5	1348	4910	6	228
4175	5	424	4420	5	880	4680	5	1357	4915	6	236
4180	5	433	4425	5	889	4685	5	1366	4920	6	243
4185	5	442	4430	5	898	4690	5	1376	4925	6	251
4190	5	452	4435	5	907	4695	5	1385	4930	6	259
4195	5	461	4440	5	917	4700	5	1394	4935	6	267
<b>4200</b>	<b>5</b>	<b>470</b>	4445	5	926				4940	6	274
4205	5	479	4450	5	935	4705	5	1403	4945	6	282
4210	5	489	4455	5	944	4710	5	1412	4950	6	290
4215	5	498	4460	5	954	4715	5	1421	4955	6	298
4220	5	508	4465	5	963	4720	5	1430	4960	6	305
4225	5	517	4470	5	972	4725	5	1439	4965	6	313
4230	5	526	4475	5	981	4730	5	1449	4970	6	320
4235	5	535	4480	5	991	4735	5	1458	4975	6	328
4240	5	545	4485	5	1000	4740	5	1468	4980	6	335
4245	5	554	4490	5	1009	4745	5	1477	4985	6	343
4250	5	564	4495	5	1018	4750	5	1486	4990	6	351
			4500	5	1027	<b>4800</b>	<b>5</b>	<b>1578</b>	4995	6	359
									<b>5000</b>	<b>6</b>	<b>366</b>

Use nearest check point shown in heavy type.

Frequency 5000 to 6000 kilocycles

TABLE 3-2. (Continued)

Freq.	A	B	Freq.	A	B	Freq.	A	B	Freq.	A	B
<b>5000</b>	<b>6</b>	<b>366</b>	<b>5200</b>	<b>6</b>	<b>674</b>	5500	6	1133	5750	6	1513
5005	6	374	5250	6	752	5505	6	1141	5755	6	1521
5010	6	381	5255	6	760	5510	6	1148	5760	6	1528
5015	6	389	5260	6	767	5515	6	1156	5765	6	1536
5020	6	397	5265	6	775	5520	6	1163	5770	6	1544
5025	6	405	5270	6	782	5525	6	1171	5775	6	1552
5030	6	412	5275	6	790	5530	6	1179	5780	6	1559
5035	6	420	5280	6	797	5535	6	1187	5785	6	1567
5040	6	427	5285	6	805	5540	6	1194	5790	6	1574
5045	6	435	5290	6	813	5545	6	1202	5795	6	1582
5050	6	443	5295	6	821	5550	6	1209	<b>5800</b>	<b>6</b>	<b>1590</b>
5055	6	451	5300	6	828	5555	6	1217	5805	6	1598
5060	6	458				5560	6	1224	5810	6	1605
5065	6	466	5305	6	836	5565	6	1232	5815	6	1613
5070	6	474	5310	6	844	5570	6	1239	5820	6	1621
5075	6	482	5315	6	852	5575	6	1247	5825	6	1629
5080	6	489	5320	6	859	5580	6	1254	5830	6	1636
5085	6	497	5325	6	867	5585	6	1262	5835	6	1644
5090	6	505	5330	6	874	5590	6	1270	5840	6	1653
5095	6	513	5335	6	882	5595	6	1278	5845	6	1661
5100	6	520	5340	6	890	<b>5600</b>	<b>6</b>	<b>1285</b>	5850	6	1668
			5345	6	898	5605	6	1293	5855	6	1676
5105	6	528	5350	6	905	5610	6	1300	5860	6	1683
5110	6	535	5355	6	913	5615	6	1308	5865	6	1691
5115	6	543	5360	6	920	5620	6	1315	5870	6	1699
5120	6	551	5365	6	928	5625	6	1323	5875	6	1707
5125	6	559	5370	6	935	5630	6	1330	5880	6	1715
5130	6	567	5375	6	943	5635	6	1338	5885	6	1723
5135	6	575	5380	6	951	5640	6	1345	5890	6	1731
5140	6	582	5385	6	959	5645	6	1353	5895	6	1739
5145	6	590	5390	6	966	5650	6	1361	5900	6	1747
5150	6	597	5395	6	974	5655	6	1369			
5155	6	605	<b>5400</b>	<b>6</b>	<b>981</b>	5660	6	1376	5905	6	1755
5160	6	613	5405	6	989	5665	6	1384	5910	6	1763
5165	6	621	5410	6	996	5670	6	1391	5915	6	1771
5170	6	628	5415	6	1004	5675	6	1399	5920	6	1779
5175	6	636	5420	6	1012	5680	6	1406	5925	6	1787
5180	6	644	5425	6	1020	5685	6	1414	5930	6	1795
5185	6	652	5430	6	1027	5690	6	1421	5935	6	1803
5190	6	659	5435	6	1035	5695	6	1429	5940	6	1811
5195	6	667	5440	6	1042	5700	6	1436	5945	6	1819
<b>5200</b>	<b>6</b>	<b>674</b>	5445	6	1050				5950	6	1827
5205	6	682	5450	6	1057	5705	6	1444	5955	6	1835
5210	6	690	5455	6	1065	5710	6	1452	5960	6	1844
5215	6	698	5460	6	1073	5715	6	1460	5965	6	1852
5220	6	705	5465	6	1081	5720	6	1467	5970	6	1860
5225	6	713	5470	6	1088	5725	6	1475	5975	6	1868
5230	6	721	5475	6	1096	5730	6	1482	5980	6	1877
5235	6	729	5480	6	1103	5735	6	1490	5985	6	1885
5240	6	736	5485	6	1111	5740	6	1498	5990	6	1893
5245	6	744	5490	6	1118	5745	6	1506	5995	6	1901
5250	6	752	5495	6	1126	5750	6	1513	<b>6000</b>	<b>6</b>	<b>1910</b>
			5500	6	1133	<b>5800</b>	<b>6</b>	<b>1590</b>			

Use nearest check point shown in heavy type.

Frequency 6000 to 7000 kilocycles

TABLE 3-2. (Continued)

Freq.	A	B	Freq.	A	B	Freq.	A	B	Freq.	A	B
<b>6000</b>	<b>7</b>	<b>100</b>	6250	7	408	6500	7	719	6750	7	1027
6005	7	106	6255	7	415	6505	7	725	6755	7	1033
6010	7	112	6260	7	421	6510	7	732	6760	7	1039
6015	7	119	6265	7	427	6515	7	738	6765	7	1046
6020	7	125	6270	7	433	6520	7	744	6770	7	1052
6025	7	131	6275	7	439	6525	7	750	6775	7	1058
6030	7	138	6280	7	445	6530	7	756	6780	7	1064
6035	7	144	6285	7	452	6535	7	762 (1.2 divisions per kc)	6785	7	1070
6040	7	150	6290	7	458	6540	7	769	6790	7	1076
6045	7	156	6295	7	464	6545	7	775	6795	7	1083
6050	7	162	<b>6300</b>	<b>7</b>	<b>470</b>	6550	7	781	6800	7	1089
6055	7	168	6305	7	476	6555	7	787	6805	7	1095
6060	7	174	6310	7	482	6560	7	793	6810	7	1101
6065	7	180	6315	7	489	6565	7	799 (1.2 divisions per kc)	6815	7	1107
6070	7	186	6320	7	495	6570	7	806	6820	7	1113
6075	7	193	6325	7	501	6575	7	812	6825	7	1119
6080	7	199	6330	7	508	6580	7	818	6830	7	1125
6085	7	205	6335	7	514	6585	7	824	6835	7	1131
6090	7	211	6340	7	520	6590	7	830	6840	7	1138
6095	7	217	6345	7	526 (1.2 divisions per kc)	6595	7	836	6845	7	1144
6100	7	223	6350	7	532	<b>6600</b>	<b>7</b>	<b>843</b>	6850	7	1150
6105	7	230	6355	7	538	6605	7	849	6855	7	1156
6110	7	236	6360	7	545 (1.2 divisions per kc)	6610	7	855	6860	7	1162
6115	7	242	6365	7	551	6615	7	862	6865	7	1168
6120	7	248	6370	7	557	6620	7	868	6870	7	1174
6125	7	254	6375	7	564	6625	7	874	6875	7	1180
6130	7	260	6380	7	570	6630	7	880	6880	7	1186
6135	7	267	6385	7	576	6635	7	886	6885	7	1193
6140	7	273	6390	7	582	6640	7	892	6890	7	1199
6145	7	279	6395	7	588	6645	7	898	6895	7	1205
6150	7	285	6400	7	595	6650	7	904	<b>6900</b>	<b>7</b>	<b>1211</b>
			6405	7	601	6655	7	910	6905	7	1217
			6410	7	607	6660	7	917	6910	7	1223
6155	7	291	6415	7	613	6665	7	923	6915	7	1229
6160	7	297	6420	7	620	6670	7	929 (1.2 divisions per kc)	6920	7	1235
6165	7	303	6425	7	626	6675	7	935	6925	7	1241
6170	7	309	6430	7	632	6680	7	941	6930	7	1247
6175	7	315	6435	7	638	6685	7	947	6935	7	1253
6180	7	322	6435	7	638	6690	7	954 (1.2 divisions per kc)	6940	7	1259
6185	7	328	6440	7	644	6695	7	960	6945	7	1266
6190	7	334	6445	7	650	6700	7	966 (1.2 divisions per kc)	6950	7	1272
6195	7	340	6450	7	657	6705	7	972	6955	7	1278
6200	7	346				6710	7	978	6960	7	1284
6205	7	352	6455	7	663	6715	7	984	6965	7	1290
6210	7	359	6460	7	669	6720	7	991	6970	7	1296
6215	7	365	6465	7	675	6725	7	997	6975	7	1302
6220	7	371	6470	7	681	6730	7	1003	6980	7	1308
6225	7	377 (1.2 divisions per kc)	6475	7	687	6735	7	1009	6985	7	1314
6230	7	383	6480	7	693	6740	7	1015	6990	7	1321
6235	7	389	6485	7	699	6745	7	1021	6995	7	1327
6240	7	396	6490	7	705	6750	7	1027	7000	7	1333
6245	7	402	6495	7	713 (1.2 divisions per kc)						
6250	7	408	6500	7	719						
<b>6300</b>	<b>7</b>	<b>470</b>	<b>6600</b>	<b>7</b>	<b>843</b>						

Use nearest check point shown in heavy type.

Frequency 7000 to 8000 kilocycles

TABLE 3-2. (Continued)

Freq.	A	B	Freq.	A	B	Freq.	A	B	Freq.	A	B
<b>6900</b>	<b>7</b>	<b>1211</b>	<b>7200</b>	<b>8</b>	<b>060</b>	<b>7500</b>	<b>8</b>	<b>366</b>	7750	8	623
7000	7	1333	7250	8	111	7505	8	371	7755	8	623
7005	7	1339	7255	8	116	7510	8	376	7760	8	633
7010	7	1345	7260	8	121	7515	8	381	7765	8	638
7015	7	1351	7265	8	126	7520	8	386	7770	8	644
7020	7	1357	7270	8	131	7525	6	391	7775	8	649
7025	7	1363	7275	8	137	7530	8	397	7780	8	654
7030	7	1369	7280	8	142	7535	8	402	7785	8	659
7035	7	1376	7285	8	147	7540	8	407	7790	8	664
7040	7	1382	7290	8	152	7545	8	412	7795	8	669
7045	7	1388	7295	8	157	7550	8	417	<b>7800</b>	<b>8</b>	<b>674</b>
7050	7	1394	7300	8	162				7805	8	679
			7305	8	168	7555	8	422	7810	8	684
7055	7	1400	7310	8	173	7560	8	427	7815	8	690
7060	7	1406	7315	8	178	7565	8	432	7820	8	695
7065	7	1412	7320	8	183	7570	8	437	7825	8	700
7070	7	1418	7325	8	188	7575	8	443	7830	8	705
7075	7	1424	7330	8	193	7580	8	448	7835	8	710
7080	7	1430	7335	8	198	7585	8	453	7840	8	715
7085	7	1436	7340	8	203	7590	8	458	7845	8	721
7090	7	1442	7345	8	208	7595	8	463	7850	8	726
7095	7	1449	7350	8	213	7600	8	469	7855	8	731
7100	7	1455				7605	8	474	7860	8	736
7105	7	1461	7355	8	218	7610	8	479	7865	8	741
7110	7	1468	7360	8	223	7615	8	484	7870	8	746
7115	7	1474	7365	8	228	7620	8	489	7875	8	752
7120	7	1480	7370	8	233	7625	8	494	7880	8	757
7125	7	1486	7375	8	238	7630	8	499	7885	8	762
7130	7	1492	7380	8	243	7635	8	505	7890	8	767
7135	7	1498	7385	8	248	7640	8	510	7895	8	772
7140	7	1504	7390	8	253	7645	8	515	7900	8	777
7145	7	1510	7395	8	259	7650	8	520	7905	8	782
7150	7	1516	7400	8	264				7910	8	787
7155	7	1523	7405	8	269	7655	8	525	7915	8	792
7160	7	1529	7410	8	274	7660	8	530	7920	8	797
7165	7	1535	7415	8	279	7665	8	535	7925	8	802
7170	7	1541	7420	8	284	7670	8	540	7930	8	807
7175	7	1547	7425	8	290	7675	8	545	7935	8	813
7180	7	1553	7430	8	295	7680	8	551	7940	8	818
7185	7	1560	7435	8	300	7685	8	556	7945	8	823
7190	7	1566	7440	8	305	7690	8	561	7950	8	828
7195	7	1572	7445	8	310	7695	8	567			
<b>7200</b>	<b>7</b>	<b>1578</b>	7450	8	315	7700	8	572	7955	8	833
			7455	8	320	7705	8	577	7960	8	838
<b>7200</b>	<b>8</b>	<b>060</b>	7460	8	325	7710	8	582	7965	8	844
7205	8	065	7465	8	330	7715	8	587	7970	8	849
7210	8	070	7470	8	335	7720	8	592	7975	8	854
7215	8	076	7475	8	340	7725	8	597	7980	8	859
7220	8	081	7480	8	345	7730	8	602	7985	8	864
7225	8	086	7485	8	351	7735	8	607	7990	8	869
7230	8	091	7490	8	356	7740	8	613	7995	8	874
7235	8	096	7495	8	361	7745	8	618	8000	8	879
7240	8	101	<b>7500</b>	<b>8</b>	<b>366</b>	7750	8	623	<b>8100</b>	<b>8</b>	<b>981</b>
7245	8	106				<b>7800</b>	<b>8</b>	<b>674</b>			
7250	8	111									

Use nearest check point shown in heavy type.

Frequency 8000 to 10000 kilocycles

TABLE 3-2. (Continued)

Freq.	A	B	Freq.	A	B	Freq.	A	B	Freq.	A	B
8000	8	879	<b>8400</b>	<b>8</b>	<b>1285</b>	<b>9000</b>	<b>9</b>	<b>100</b>	<b>9450</b>	<b>9</b>	<b>470</b>
8010	8	890	8500	8	1386	9010	9	108	9500	9	510
8020	8	900	8510	8	1396	9020	9	116	9510	9	518
8030	8	910	8520	8	1406	9030	9	124	9520	9	527
8040	8	920	8530	8	1416	9040	9	132	9530	9	536
8050	8	930	8540	8	1426	9050	9	140	9540	9	545
8060	8	940	8550	8	1436	9060	9	148	9550	9	553
8070	8	951				9070	9	156	9560	9	561
8080	8	961	8560	8	1446	9080	9	165	9570	9	570
8090	8	971	8570	8	1456	9090	9	174	9580	9	578
<b>8100</b>	<b>8</b>	<b>981</b>	8580	8	1467	9100	9	182	9590	9	586
8110	8	991	8590	8	1477	9110	9	190	9600	9	595
8120	8	1001	8600	8	1487	9120	9	198	9610	9	601
8130	8	1012	8610	8	1498	9130	9	206	9620	9	610
8140	8	1022	8620	8	1508	9140	9	214	9630	9	620
8150	8	1032	8630	8	1518	9150	9	222	9640	9	628
8160	8	1042	8640	8	1528	9160	9	230	9650	9	636
8170	8	1052	8650	8	1538	9170	9	239	9660	9	644
8180	8	1062	8660	8	1548	9180	9	248	9670	9	652
8190	8	1073	8670	8	1559	9190	9	256			
8200	8	1083	8680	8	1569	9200	9	264	9680	9	660
8210	8	1093	8690	8	1579	9210	9	272	9690	9	668
8220	8	1103	<b>8700</b>	<b>8</b>	<b>1590</b>	9220	9	280	9700	9	676
8230	8	1113	8710	8	1600				9710	9	684
8240	8	1123	8720	8	1610	9230	9	288	9720	9	693
8250	8	1133	8730	8	1621	9240	9	296	9730	9	701
			8740	8	1631	9250	9	304	9740	9	709
8260	8	1143	8750	8	1641	9260	9	313	9750	9	717
8270	8	1153	8760	8	1653	9270	9	322	9760	9	725
8280	8	1163	8770	8	1663	9280	9	330	9770	9	733
8290	8	1173	8780	8	1673	9290	9	338	9780	9	742
8300	8	1183	8790	8	1683	9300	9	346	9790	9	751
8310	8	1194	8800	8	1694	9310	9	354	9800	9	760
8320	8	1204	8810	8	1704	9320	9	362	9810	9	769
8330	8	1214	8820	8	1715	9330	9	370	9820	9	777
8340	8	1224	8830	8	1725	9340	9	378	9830	9	785
8350	8	1234	8840	8	1736	9350	9	387	9840	9	793
8360	8	1244	8850	8	1747	9360	9	396	9850	9	801
8370	8	1254				9370	9	404	9860	9	809
8380	8	1264	8860	8	1757	9380	9	412	9870	9	817
8390	8	1274	8870	8	1768	9390	9	420	9880	9	825
<b>8400</b>	<b>8</b>	<b>1285</b>	8880	8	1779	9400	9	428	9890	9	834
8410	8	1295	8890	8	1789	9410	9	436	<b>9900</b>	<b>9</b>	<b>843</b>
8420	8	1305	8900	8	1799	9420	9	444	9910	9	851
8430	8	1315	8910	8	1811	9430	9	452	9920	9	859
8440	8	1325	8920	8	1821	9440	9	461	9930	9	867
8450	8	1335	8930	8	1832	<b>9450</b>	<b>9</b>	<b>470</b>	9940	9	875
8460	8	1345	8940	8	1843	9460	9	478	9950	9	883
8470	8	1355	8950	8	1854	9470	9	486	9960	9	891
8480	8	1365	8960	8	1865	9480	9	494	9970	9	899
8490	8	1376	8970	8	1877	9490	9	502	9980	9	908
8500	8	1386	8980	8	1888	9500	9	510	9990	9	917
			8990	8	1899				10000	9	925
			<b>9000</b>	<b>8</b>	<b>1910</b>						

Use nearest check point shown in heavy type.



## Frequency 10000 to 12000 kilocycles

TABLE 3-2. (Continued)

Freq.	A	B	Freq.	A	B	Freq.	A	B	Freq.	A	B
<b>9900</b>	<b>9</b>	<b>843</b>	<b>10350</b>	<b>9</b>	<b>1211</b>	<b>10800</b>	<b>10</b>	<b>060</b>	11500	10	538
10000	9	925	10500	9	1333	11000	10	195	11510	10	545
10010	9	933	10510	9	1341	11010	10	202	11520	10	551
10020	9	941	10520	9	1349	11020	10	209	11530	10	557
10030	9	949	10530	9	1357	11030	10	216	11540	10	563
10040	9	957	10540	9	1365	11040	10	223	11550	10	570
10050	9	965	10550	9	1373	11050	10	230	11560	10	577
10060	9	973	10560	9	1381	11060	10	237	11570	10	584
10070	9	982	10570	9	1389	11070	10	243	11580	10	591
10080	9	991				11080	10	249	11590	10	598
10090	9	999	10580	9	1397	11090	10	256	11600	10	605
10100	9	1007	10590	9	1405	11100	10	264	11610	10	613
10110	9	1015	10600	9	1413	11110	10	270	11620	10	619
10120	9	1023	10610	9	1421	11120	10	277	11630	10	625
			10620	9	1430	11130	10	284	11640	10	632
10130	9	1031	10630	9	1438	11140	10	291	11650	10	639
10140	9	1039	10640	9	1446	11150	10	297	11660	10	646
10150	9	1047	10650	9	1454	11160	10	305	11670	10	653
10160	9	1055	10660	9	1462	11170	10	311	11680	10	660
10170	9	1064	10670	9	1470	11180	10	317	11690	10	667
10180	9	1072	10680	9	1478	11190	10	324	<b>11700</b>	<b>10</b>	<b>674</b>
10190	9	1080	10690	9	1486	11200	10	331	11710	10	680
10200	9	1089	10700	9	1494	11210	10	338	11720	10	687
10210	9	1097	10710	9	1504	11220	10	345	11730	10	694
10220	9	1105	10720	9	1512	11230	10	352	11740	10	701
10230	9	1113	10730	9	1520	11240	10	359	11750	10	708
10240	9	1121	10740	9	1528	<b>11250</b>	<b>10</b>	<b>366</b>	11760	10	715
10250	9	1129	10750	9	1536	11260	10	372	11770	10	722
10260	9	1138	10760	9	1544	11270	10	378	11780	10	729
10270	9	1146	10770	9	1552	11280	10	385	11790	10	736
10280	9	1154	10780	9	1560	11290	10	392	11800	10	742
10290	9	1162	10790	9	1569	11300	10	399	11810	10	748
10300	9	1170	<b>10800</b>	<b>9</b>	<b>1578</b>	11310	10	406	11820	10	755
10310	9	1178				11320	10	413	11830	10	762
10320	9	1186	<b>10800</b>	<b>10</b>	<b>060</b>	11330	10	420	11840	10	769
10330	9	1194	10810	10	066	11340	10	427	11850	10	776
10340	9	1202	10820	10	072	11350	10	433			
<b>10350</b>	<b>9</b>	<b>1211</b>	10830	10	079	11360	10	440	11860	10	783
10360	9	1219	10840	10	086	11370	10	447	11870	10	790
10370	9	1227	10850	10	093	11380	10	454	11880	10	797
10380	9	1235	10860	10	100	11390	10	462	11890	10	803
10390	9	1243	10870	10	107	11400	10	469	11900	10	810
10400	9	1251	10880	10	114	11410	10	475	11910	10	817
10410	9	1259	10890	10	121	11420	10	482	11920	10	824
10420	9	1267	10900	10	127	11430	10	489	11930	10	831
10430	9	1275	10910	10	134	11440	10	495	11940	10	838
10440	9	1284	10920	10	141	11450	10	503	11950	10	845
10450	9	1292	10930	10	148	11460	10	510	11960	10	852
10460	9	1300	10940	10	155	11470	10	517	11970	10	859
10470	9	1308	10950	10	162				11980	10	866
10480	9	1316	10960	10	169	11480	10	524	11990	10	873
10490	9	1324	10970	10	176	11490	10	531	<b>12000</b>	<b>10</b>	<b>879</b>
10500	9	1333	10980	10	183	11500	10	538			
			10990	10	189	<b>11700</b>	<b>10</b>	<b>674</b>			
			11000	10	195						

Use nearest check point shown in heavy type.

Frequency 12000 to 14000 kilocycles

TABLE 3-2. (Continued)

Freq.	A	B	Freq.	A	B	Freq.	A	B	Freq.	A	B
<b>12000</b>	<b>11</b>	<b>100</b>	12500	11	408	13000	11	719	13500	11	1027
12010	11	106	12510	11	415	13010	11	725	10510	11	1033
12020	11	112	12520	11	421	13020	11	732	13520	11	1039
12030	11	119	12530	11	427	13030	11	738	13530	11	1046
12040	11	125	12540	11	433	13040	11	744	13540	11	1052
12050	11	131	12550	11	439	13050	11	750	13550	11	1058
12060	11	138	12560	11	445	13060	11	756	13560	11	1064
12070	11	144	12570	11	452	13070	11	762	13570	11	1070
12080	11	150	12580	11	458	13080	11	769	13580	11	1076
12090	11	156	12590	11	464	13090	11	775	13590	11	1083
12100	11	162	<b>12600</b>	<b>11</b>	<b>470</b>	13100	11	781	13600	11	1089
12110	11	168	12610	11	476	13110	11	787	13610	11	1095
12120	11	174	12620	11	482	13120	11	793	13620	11	1101
12130	11	180	12630	11	489	13130	11	799	13630	11	1107
12140	11	187	12640	11	495	13140	11	806	13640	11	1113
12150	11	193	12650	11	501	13150	11	812	13650	11	1119
12160	11	199	12660	11	508	13160	11	818	13660	11	1125
12170	11	205	12670	11	514	13170	11	824	13670	11	1131
12180	11	211	12680	11	520	13180	11	830	13680	11	1138
12190	11	217	12690	11	526	13190	11	836	13690	11	1144
12200	11	223	12700	11	532	<b>13200</b>	<b>11</b>	<b>843</b>	13700	11	1150
12210	11	230	12710	11	538	13210	11	849	13710	11	1156
12220	11	236	12720	11	545	13220	11	855	13720	11	1162
12230	11	242	12730	11	551	13230	11	862	13730	11	1168
12240	11	248	12740	11	557	13240	11	868	13740	11	1174
12250	11	254	12750	11	564	13250	11	874	13750	11	1180
12260	11	260	12760	11	570	13260	11	880	13760	11	1186
12270	11	267	12770	11	576	13270	11	886	13770	11	1193
12280	11	273	12780	11	582	13280	11	892	13780	11	1199
12290	11	279	12790	11	590	13290	11	898	13790	11	1205
			12800	11	595	13300	11	904	<b>13800</b>	<b>11</b>	<b>1211</b>
12300	11	285	12810	11	601	13310	11	910	13810	11	1217
12310	11	291	12820	11	607	13320	11	917	13820	11	1223
12320	11	297	12830	11	613	13330	11	923	13830	11	1229
12330	11	303	12840	11	620	13340	11	929	13840	11	1235
12340	11	309	12850	11	626	13350	11	935	13850	11	1241
12350	11	315	12860	11	632	13360	11	941	13860	11	1247
12360	11	322	12870	11	638	13370	11	947	13870	11	1253
12370	11	328	12880	11	644	13380	11	954	13880	11	1259
12380	11	334	12890	11	650	13390	11	960	13890	11	1266
12390	11	340	12900	11	657	13400	11	966	13900	11	1272
12400	11	346							13910	11	1278
12410	11	352	12910	11	663	13410	11	972	13920	11	1284
12420	11	359	12920	11	669	13420	11	980	13930	11	1290
12430	11	365	12930	11	675	13430	11	986	13940	11	1296
12440	11	371	12940	11	681	13440	11	991	13950	11	1302
12450	11	377	12950	11	687	13450	11	997	13960	11	1308
12460	11	383	12960	11	693	13460	11	1003	13970	11	1314
12470	11	389	12970	11	699	13470	11	1009	13980	11	1321
12480	11	396	12980	11	706	13480	11	1015	13990	11	1327
12490	11	402	12990	11	713	13490	11	1021	14000	11	1333
12500	11	408	13000	11	719	13500	11	1027			
<b>12600</b>	<b>11</b>	<b>470</b>	<b>13200</b>	<b>11</b>	<b>843</b>						

Use nearest check point shown in heavy type.

Frequency 14000 to 16000 kilocycles

TABLE 3-2. (Continued)

Freq.	A	B	Freq.	A	B	Freq.	A	B	Freq.	A	B
<b>13800</b>	<b>11</b>	<b>1211</b>	<b>14400</b>	<b>12</b>	<b>060</b>	<b>15000</b>	<b>12</b>	<b>366</b>	15500	12	623
14000	11	1333	14500	12	111	15010	12	371	15510	12	628
14010	11	1339	14510	12	116	15020	12	376	15520	12	633
14020	11	1345	14520	12	121	15030	12	381	15530	12	638
14030	11	1351	14530	12	126	15040	12	386	15540	12	644
14040	11	1357	14540	12	131	15050	12	391	15550	12	649
14050	11	1363	14550	12	137	15060	12	397	15560	12	654
14060	11	1369	14560	12	142	15070	12	402	15570	12	659
14070	11	1376	14570	12	147	15080	12	407	15580	12	664
14080	11	1382	14580	12	152	15090	12	412	15590	12	669
14090	11	1388	14590	12	157	15100	12	417	<b>15600</b>	<b>12</b>	<b>674</b>
14100	11	1394	14600	12	162				15610	12	679
			14610	12	168	15110	12	422	15620	12	684
14110	11	1400	14620	12	173	15120	12	427	15630	12	689
14120	11	1406	14630	12	178	15130	12	432	15640	12	694
14130	11	1412	14640	12	183	15140	12	437	15650	12	699
14140	11	1418	14650	12	188	15150	12	443	15660	12	705
14150	11	1424	14660	12	193	15160	12	448	15670	12	710
14160	11	1430	14670	12	198	15170	12	453	15680	12	715
14170	11	1436	14680	12	203	15180	12	458	15690	12	721
14180	11	1442	14690	12	208	15190	12	463	15700	12	726
14190	11	1449	14700	12	213	15200	12	469	15710	12	731
14200	11	1455				15210	12	474	15720	12	736
14210	11	1461	14710	12	218	15220	12	479	15730	12	741
14220	11	1468	14720	12	223	15230	12	484	15740	12	746
14230	11	1474	14730	12	228	15240	12	489	15750	12	752
14240	11	1480	14740	12	233	15250	12	494	15760	12	757
14250	11	1486	14750	12	238	15260	12	499	15770	12	762
14260	11	1492	14760	12	243	15270	12	505	15780	12	767
14270	11	1498	14770	12	248	15280	12	510	15790	12	772
14280	11	1504	14780	12	253	15290	12	515	15800	12	777
14290	11	1510	14790	12	259	15300	12	520			
14300	11	1516	14800	12	264				15810	12	782
14310	11	1523	14810	12	269	15310	12	525	15820	12	787
14320	11	1529	14820	12	274	15320	12	530	15830	12	792
14330	11	1535	14830	12	279	15330	12	535	15840	12	797
14340	11	1541	14840	12	284	15340	12	540	15850	12	802
14350	11	1547	14850	12	290	15350	12	545	15860	12	807
14360	11	1553	14860	12	295	15360	12	551	15870	12	813
14370	11	1560	14870	12	300	15370	12	556	15880	12	818
14380	11	1566	14880	12	305	15380	12	561	15890	12	823
14390	11	1572	14890	12	310	15390	12	567	15900	12	828
<b>14400</b>	<b>11</b>	<b>1578</b>	14900	12	315	15400	12	572			
			14910	12	320	15410	12	577	15910	12	833
<b>14400</b>	<b>12</b>	<b>060</b>	14920	12	325	15420	12	582	15920	12	838
14410	12	065	14930	12	330	15430	12	587	15930	12	844
14420	12	070	14940	12	335	15440	12	592	15940	12	849
14430	12	076	14950	12	340	15450	12	597	15950	12	854
14440	12	081	14960	12	345	15460	12	602	15960	12	859
14450	12	086	14970	12	351	15470	12	607	15970	12	864
14460	12	091	14980	12	356	15480	12	613	15980	12	869
14470	12	096	14990	12	361	15490	12	618	15990	12	874
14480	12	101	<b>15000</b>	<b>12</b>	<b>366</b>	15500	12	623	16000	12	879
14490	12	106				<b>15600</b>	<b>12</b>	<b>674</b>	<b>16200</b>	<b>12</b>	<b>981</b>
14500	12	111									

Use nearest check point shown in heavy type.

Frequency 16000 to 18100 kilocycles

TABLE 3-2. (Continued)

Freq.	A	B	Freq.	A	B	Freq.	A	B	Freq.	A	B
16000	12	879	16500	12	1133	<b>16800</b>	<b>12</b>	<b>1285</b>	<b>17400</b>	<b>12</b>	<b>1590</b>
16010	12	884	16510	12	1138	17000	12	1386	17550	12	1668
16020	12	890	16520	12	1143	17010	12	1391	17560	12	1673
16030	12	895	16530	12	1148	17020	12	1396	17570	12	1678
16040	12	900	16540	12	1153	17030	12	1401	17580	12	1683
16050	12	905	16550	12	1158	17040	12	1406	17590	12	1688
16060	12	910	16560	12	1163	17050	12	1411	17600	12	1694
16070	12	915	16570	12	1168	17060	12	1416	17610	12	1699
16080	12	920	16580	12	1173	17070	12	1421	17620	12	1704
16090	12	925	16590	12	1179	17080	12	1426	17630	12	1709
16100	12	930	16600	12	1184	17090	12	1431	17640	12	1715
16110	12	935	16610	12	1189	17100	12	1436	17650	12	1720
16120	12	940	16620	12	1194				17660	12	1725
16130	12	945	16630	12	1199	17110	12	1441	17670	12	1731
16140	12	951	16640	12	1204	17120	12	1446	17680	12	1736
16150	12	956	16650	12	1209	17130	12	1452	17690	12	1742
16160	12	961	16660	12	1214	17140	12	1457	17700	12	1747
16170	12	966	16670	12	1219	17150	12	1462			
16180	12	971	16680	12	1224	17160	12	1467	17710	12	1752
16190	12	976	16690	12	1229	17170	12	1472	17720	12	1757
<b>16200</b>	<b>12</b>	<b>981</b>	16700	12	1234	17180	12	1477	17730	12	1763
16210	12	986	16710	12	1239	17190	12	1482	17740	12	1768
16220	12	991	16720	12	1244	17200	12	1487	17750	12	1773
16230	12	996	16730	12	1249	17210	12	1492	17760	12	1779
16240	12	1001	16740	12	1254	17220	12	1498	17770	12	1784
16250	12	1006	16750	12	1259	17230	12	1503	17780	12	1789
16260	12	1012	16760	12	1264	17240	12	1508	17790	12	1795
16270	12	1017	16770	12	1270	17250	12	1513	17800	12	<b>1800</b>
16280	12	1022	16780	12	1275	17260	12	1518	17810	12	1805
16290	12	1027	16790	12	1280	17270	12	1523	17820	12	1811
16300	12	1032	<b>16800</b>	<b>12</b>	<b>1285</b>	17280	12	1528	17830	12	1816
16310	12	1037	16810	12	1290	17290	12	1533	17840	12	1821
16320	12	1042	16820	12	1295	17300	12	1538	17850	12	1827
16330	12	1047	16830	12	1300	17310	12	1544	17860	12	1832
16340	12	1052	16840	12	1305	17320	12	1549	17870	12	1837
16350	12	1057	16850	12	1310	17330	12	1554	17880	12	1843
16360	12	1062	16860	12	1315	17340	12	1559	17890	12	1848
16370	12	1067	16870	12	1320	17350	12	1564	17900	12	1854
16380	12	1073	16880	12	1325	17360	12	1569	17910	12	1860
16390	12	1078	16890	12	1330	17370	12	1574	17920	12	1865
16400	12	1083	16900	12	1335	17380	12	1579	17930	12	1871
16410	12	1088	16910	12	1340	17390	12	1584	17940	12	1877
16420	12	1093	16920	12	1345	<b>17400</b>	<b>12</b>	<b>1590</b>	17950	12	1882
16430	12	1098	16930	12	1350	17410	12	1595	17960	12	1888
16440	12	1103	16940	12	1355	17420	12	1600	17970	12	1893
16450	12	1108	16950	12	1361	17430	12	1605	17980	12	1898
16460	12	1113	16960	12	1366	17440	12	1610	17990	12	1904
16470	12	1118	16970	12	1371	17450	12	1615	<b>18000</b>	<b>12</b>	<b>1910</b>
16480	12	1123	16980	12	1376	17460	12	1621	18010	12	1915
16490	12	1128	16990	12	1381	17470	12	1626	18020	12	1921
16500	12	1133	17000	12	1386	17480	12	1631	18030	12	1927
						17490	12	1636	18040	12	1933
						17500	12	1641	18050	12	1939
						17510	12	1647	18060	12	1944
						17520	12	1653	18070	12	1949
						17530	12	1658	18080	12	1955
						17540	12	1663	18090	12	1961
						17550	12	1668	18100	12	1966

Use nearest check point shown in heavy type.

**4. TUNING INSTRUCTIONS FOR LOW FREQUENCY  
OPERATION BELOW 2000 KC.**

a. Knobs "F" and "G" are coarse and fine frequency controls respectively. Knob "A" MUST be set at 13. Knobs "B", "D", and "E" have no effect on low frequency tuning. They will rotate when automatically shifting to low frequency, but their final position is unimportant. Knob "C" must be set to number 8 since this position allows the least power to be dissipated in the high frequency output circuits. All antenna tuning controls are located on the external loading coil.

b. The following procedure is recommended for tuning the equipment on a desired low frequency:

(1) Set transmitter to desired frequency using Knobs "F" and "G". See instructions paragraph 3. b. of this section and calibration tables 3-1 and 3-1A.

(2) Use loading coil of type shown in following table:

Frequency	"AN" Type	Length of Trailing Wire
200-600 kc	CU-25/ART-13	200 ft.
200-600 kc	CU-32/ART-13A	200 ft.
500-1100 kc	CU-26/ART-13	200 ft.
1100-1500 kc	CU-26/ART-13	150 ft.

(3) Reel out trailing wire antenna to length shown in above table.

(4) Place BATTERY - P.A. GRID - P.A. PLATE switch in P.A. PLATE position.

(5) Place CALIBRATE-TUNE-OPERATE switch in TUNE position.

(6) Place EMISSION switch in CW position.

(7) See that Knob "A" is in Position 13.

(8) Set the tap switch (Knob "K" on CU-25/ART-13) (Knob "H" on CU-26/ART-13) on the loading coil to the desired frequency, using the rough frequency calibration by the knob as a guide.

(9) Press key. Rotate the fine tuning control (Knob "L" with CU-25/ART-13) (Knob "J" with CU-26/ART-13) for minimum P.A. plate meter reading. If no sharp dip is found, move the tap switch on the loading coil one position and retune the fine tuning control. If no dip is found, move the tap switch one position the other way and try again. Set and lock (Knob "L" on CU-25/ART-13) (Knob "J" on CU-26/ART-13) at the position of minimum P.A. PLATE meter reading. Release key.

**Note**

The resonant point lowest in frequency must be found to prevent doubling of frequency in the output circuit.

(10) Place CALIBRATE-TUNE-OPERATE switch in OPERATE position. The transmitter is now ready for use.

**Note**

The correct tuning point is at minimum P.A. plate meter reading. The actual value of P.A. plate meter reading is of little importance and will vary between 20 and 110 on the numbered scale, depending on frequency. DO NOT detune any of the knobs to make the meter read in the CW area on the scale. The transmitter is operated below maximum loading on some low frequencies in order to reduce flash-over troubles in the loading coil and fairlead at high altitudes.

**5. TUNING INSTRUCTIONS FOR HIGH FREQUENCY  
OPERATION IN THE RANGE 2000 KC  
TO 18,100 KC.**

a. Knobs "A" and "B" are coarse and fine frequency controls respectively. Knobs "C", "D", and "E" tune the antenna circuit. Knobs "F" and "G" and all knobs on external loading coils have no effect during high frequency operation.

b. The following procedure is recommended for tuning the equipment to any desired high frequency:

(1) One of the tables of dial settings for "C", "D" and "E" in table 3-3. or table 3-4. will be found to be approximately correct for any aircraft antenna installation. To determine which table to use, measure the length of the antenna taking the total length of wire from the antenna terminal of the T-47/ART-13 transmitter to the extreme end of the antenna (include the length of lead inside the airplane). If the antenna is a "T" disregard the length of wire in the shorter branch at the top of the "T", or, if the two branches are equal, include the length of only one of them.

(2) To check the choice of table, tune the set to one of the frequencies given in the table for the antenna length nearest that measured above. Choose a frequency which tunes on position 7 on the "C" dial. Compare the actual dial settings obtained with the dial settings given in this table and also in tables for the next shorter and the next longer antenna lengths. Of these three tables the one showing dial settings closest to the actual dial settings is the table to use for this particular

installation. The above procedure need only be followed once for a given type of antenna installation. Once the particular table which applies is known, it can be used thereafter.

(3) Set transmitter to the desired frequency with knobs "A" and "B". See instructions paragraph 3., c. in this book, and calibration table 3-2.

(4) Set Knobs "C", "D", and "E" to the dial settings given in the table chosen above for the frequency nearest to the desired frequency. Some of the tables give two sets of dial settings for the same frequency. Use the dial settings which give most nearly correct P.A. PLATE meter reading when tuned as described below.

(5) Place BATTERY - P.A. GRID - P.A. PLATE switch in P.A. PLATE position.

(6) Place CALIBRATE - TUNE - OPERATE switch in TUNE position.

(7) Place EMISSION switch in CW position.

(8) Press key. Turn Knob "D" for minimum P.A. PLATE meter reading.

(9) Place CALIBRATE - TUNE - OPERATE switch in OPERATE position. The pointer of the meter reading P.A. plate should be in the white area marked CW. If the needle does not read in the area marked CW, detune Knob "E" a few degrees and retune Knob "D" to minimum P.A. plate meter reading. If the new meter reading is more nearly correct, detune Knob "E" a few more degrees the same direction and retune with Knob "D". If the new meter reading is farther from correct value, detune Knob "E" a few degrees the other way and find dip in P.A. plate meter reading with Knob "D". Continue until the dip in P.A. plate meter reading falls within the area marked CW. Release key.

The object is to make the meter reading at the dip fall within the white CW area on the meter scale. Knob "E" controls loading while Knob "D" controls fine antenna tuning, but their effects are interlocking. If one knob is turned, it is necessary to readjust the other.

## WARNING

The correct tuning is at the minimum dip in P.A. PLATE meter reading. If meter reading is too low, follow the procedure described above. Do not detune from minimum dip to get the "correct" meter reading. Always tune to the minimum dip in P.A. PLATE meter reading as the final step.

## Note

Set Knob "C" accurately to mark.

(10) In the tuning process the knobs have been moved either direction as required. It is now necessary to set and lock these knobs so the Autotune quick-shift mechanism will retune them automatically to the correct position. Note the setting of Knob "C". Move it one position counterclockwise, (to next lower number) then back clockwise to the original setting, stopping exactly on the mark. Hold knob and tighten locking bar.

Note the setting of Knob "D". Move it one-eighth turn counterclockwise, then return it clockwise to the exact original setting. Hold knob and tighten locking bar.

Turn Knob "E" one-eighth turn counterclockwise. Press key. Retune Knob "E" slowly clockwise and stop at minimum P.A. PLATE meter reading. If you turn past the point of minimum P.A. PLATE meter reading, back up one-eighth turn and try again. Set Knob "E" at the point of dip in P.A. PLATE meter reading, hold knob, and tighten locking bar. Release key. The equipment is now tuned and ready for use.

(11) A useful check on accuracy of setup is, after all locking bars are tightened, to turn each knob by hand clockwise against its stop, then press key momentarily and note if the set is correctly tuned. If so, the Autotune quick-shift mechanism will repeat the settings thereafter.

(12) The transmitter can be tuned and loaded with low battery voltage if proper allowance is made so that the loading will not be too high with normal battery voltage. Switch the right-hand meter to read BATTERY and note the meter reading. Switch the meter back to read P.A. PLATE and proceed to tune the antenna as described in paragraph 9 above, but adjust minimum P.A. plate meter reading to the meter reading obtained above rather than to the area marked CW. Thus when the battery voltage is low, the transmitter is loaded proportionately low, and the loading will be correct when battery voltage is normal.

(13) All antenna tuning and loading should be done in the CW position. Upon switching to VOICE position the reading of the right-hand meter will increase slightly without modulation, and will kick upwards to about 150 on the scale during normal talking. In the MCW position the meter will read in or near the area marked MCW.

## Note

Under no circumstances should the transmitter be actually operating (key down

AN 08-30ART13-5

or microphone push-button closed) when the EMISSION selector switch is operated. Such operation, especially at high altitudes, can cause a sustained arc to occur between the contacts of the CW relay.

(14) Antenna tuning data for antennas of various lengths are given in the following table. Use the data in table 3-3. where the lowest desired frequency can be tuned with the particular antenna in use.

(15) If it is necessary to tune to a lower fre-

quency than is possible with the given antenna alone, the Type CU-24/ART-13 shunt capacitors may be connected between the terminals on the transmitter marked COND. and GROUND. This additional capacity will extend the tuning range. Antenna tuning data in table 3-4. shows the amount of shunt capacity to use with each antenna to reach 2000 kcs.

**IMPORTANT**

Use table 3-3. whenever possible. Use table 3-4. only when shunt capacity must be added to extend antenna tuning range.

TABLE 3-3. TYPICAL ANTENNA TUNING DATA

DO NOT USE ANTENNA CAPACITOR

20 Ft. Antenna				22.5 Ft. Antenna				25 Ft. Antenna				27.5 Ft. Antenna			
Type Airplane:				Type Airplane:				Type Airplane:				Type Airplane:			
KC	C	D	E	KC	C	D	E	KC	C	D	E	KC	C	D	E
3000	1-2	...	70	2800	1-2	...	70	2700	1-2	...	10	2600	1	...	0
3500	2-3	...	115	3000	1-2	...	70	3000	2-3	...	60	3000	2	...	75
4000	3-4	...	130	3500	2-3	...	120	3500	3-4	...	100	3500	3-4	...	110
5000	4-5	70	150	4000	3-4	...	130	4000	4-5	...	125	4000	4-5	...	130
6000	5-6	45	170	5000	4-5	90	150	5000	5-6	...	150	5000	6	...	150
8000	6-7	30	185	6000	5-6	60	160	6000	6	80	160	6000	6-7	...	165
10000	7	75	190	8000	6-7	40	185	8000	6-7	70	180	8000	7	70	190
11000	7	90	200	10000	7	80	200	9800	7	100	200	9100	7	100	200
11300	7	100	200												
				9500	11	60	200	9000	10	75	200	9000	10	59	10
10500	11	67	200	10000	11	65	200	9500	10	85	200	9500	10	57	80
11000	11	75	200	10500	11	77	200	9500	10	65	0	10000	10	55	110
11500	11	85	200	11000	11	94	200	10000	10	65	55	11000	10	60	175
12000	11	100	200	11000	11	64	66	11000	10	65	150	12000	10	65	185
12000	11	75	30	12000	11	65	150	12000	10	70	170	14000	10	80	195
13000	11	75	140	13000	11	68	165	14000	10	85	180	15500	10	100	195
14000	11	80	164	14000	11	75	180	15000	10	95	190				
15000	11	85	170	15000	11	80	180					9000	11	45	40
								11000	11	53	160	10000	11	40	140
11500	12	60	10	11500	12	38	145	12000	11	55	180	12000	11	55	195
12000	12	55	60	12000	12	40	170	14000	11	70	200	14000	11	75	200
13000	12	55	155	13000	12	45	190	15000	11	80	200	16500	11	95	200
14000	12	60	180	14000	12	65	200	16000	11	95	200				
16000	12	75	190	16000	12	75	200								
18000	12	85	200					15000	13	0	155	16000	13	0	180
				16000	13	40	170	16000	13	0	180	17000	13	45	190
16000	13	60	150	17000	13	60	175	17000	13	35	190	18000	13	60	195
17000	13	65	170	18000	13	65	185	18000	13	55	195				
18000	13	65	180												



TABLE 3-3. TYPICAL ANTENNA TUNING DATA (Continued)

DO NOT USE ANTENNA CAPACITOR

27.5 Ft. Antenna				30 Ft. Antenna				32.5 Ft. Antenna				35 Ft. Antenna			
Type Airplane:				Type Airplane:				Type Airplane:				Type Airplane:			
_____				_____				_____				_____			
_____				_____				_____				_____			
KC	C	D	E	KC	C	D	E	KC	C	D	E	KC	C	D	E
2600	1	...	0	2500	1-2	...	20	2450	1-2	...	26	2400	1-2	...	0
3000	2	...	75	3000	3-4	...	70	3000	3	...	65	3000	3-4	...	70
3500	3-4	...	110	3500	4	...	95	3500	4-5	...	100	3500	4-5	...	100
4000	4-5	...	130	4000	4-5	...	120	4000	5	...	120	4000	5-6	...	120
5000	6	...	150	5000	5-6	...	145	5000	5-6	...	150	5000	6-7	...	145
6000	6-7	...	165	6000	6-7	...	165	6000	6-7	...	165	6000	7	...	160
8000	7	70	190	8000	7	95	180	8000	7	100	200	7000	7	...	180
9100	7	100	200	8500	7	100	200					7600	7	100	200
								7600	10	36	0				
9000	10	59	10	8200	10	48	0	8000	10	37	90	7500	8	70	0
9500	10	57	80	9000	10	48	130	9000	10	42	160	8000	8	75	40
10000	10	55	110	10000	10	50	170	10000	10	46	185	9000	8	85	62
11000	10	60	175	11000	10	55	200	11000	10	54	200	10000	8	100	100
12000	10	65	185	12000	10	63	200	12000	10	65	200	10400	8	100	126
14000	10	80	195	14000	10	82	200	13000	10	75	200				
15500	10	100	195	15000	10	92	200	14000	10	82	200	8700	11	0	175
				15600	10	98	200	14600	10	88	200	9000	11	8	180
9000	11	45	40	8000	11	62	110	8000	11	0	113	10000	11	28	200
10000	11	40	140	10000	11	32	180	9000	11	22	168	11000	11	52	200
12000	11	55	195	12000	11	45	200	10000	11	35	188	12000	11	62	200
14000	11	75	200	14000	11	65	200	11000	11	47	200	14000	11	77	200
16500	11	95	200	16000	11	90	200	12000	11	60	200	15000	11	86	200
				16600	11	98	200	14000	11	78	200	15700	11	100	190
16000	13	0	180					16000	11	100	188				
17000	13	45	190	16000	13	0	184	16200	11	100	200	15000	13	0	166
18000	13	60	195	17000	13	45	188					16000	13	66	152
				18000	13	70	188	16000	13	52	165	17000	13	84	142
								16500	13	69	160	18000	13	100	154
								17000	13	70	170				
								18000	13	75	180				

TABLE 3-3. TYPICAL ANTENNA TUNING DATA (Continued)

DO NOT USE ANTENNA CAPACITOR

35 Ft. Antenna				40 Ft. Antenna				45 Ft. Antenna				50 Ft. Antenna			
Type Airplane:				Type Airplane:				Type Airplane:				Type Airplane:			
KC	C	D	E	KC	C	D	E	KC	C	D	E	KC	C	D	E
2400	1-2	...	0	2300	1-2	...	3	2200	1-2	...	0	2100	1-2	...	0
3000	3-4	...	70	2500	2-3	...	10	2500	2-3	...	20	2500	3-4	...	19
3500	4-5	...	100	3000	3-4	...	60	3000	4-5	...	62	3000	4-5	...	55
4000	5-6	...	120	3500	4-5	...	95	3500	5-6	...	90	3500	5-6	...	95
5000	6-7	...	145	4000	5-6	...	120	4000	6	...	120	4000	6-7	...	120
6000	7	...	160	5000	6-7	...	150	5000	7	...	155	5000	7	...	160
7000	7	...	180	6000	7	...	170	6000	7	100	175	5500	7	100	180
7600	7	100	200	6800	7	100	200	6100	7	100	185				
7500	8	70	0	6600	8	57	0	6000	8	49	0	5400	8	32	0
8000	8	75	40	7000	8	60	50	7000	8	59	106	6000	8	38	90
9000	8	85	62	8000	8	70	121	8000	8	69	129	7000	8	48	148
10000	8	100	100	9000	8	83	111	9000	8	85	106	8000	8	65	152
10400	8	100	126	10000	8	97	121	9800	8	100	90	9000	8	85	148
				10500	8	100	140					10000	8	92	142
8700	11	0	175					7500	10	0	171	9000	11	29	200
9000	11	8	180	8400	10	0	188	8000	10	0	185	10000	11	40	200
10000	11	28	200	9000	10	25	196	9000	10	38	193	11000	11	53	200
11000	11	52	200	10000	10	47	200	10000	10	53	200	12000	11	72	200
12000	11	62	200	11000	10	60	200	11000	10	64	200	13000	11	82	200
14000	11	77	200	12000	10	70	200	12000	10	73	200	14000	11	100	0
15000	11	86	200	14000	10	88	200	13000	10	83	200	15000	11	98	135
15700	11	100	190	14500	10	100	200	13740	10	100	182				
15000	13	0	166	14500	12	71	200	13500	12	66	200	13500	13	37	28
16000	13	66	152	15000	12	76	200	14000	12	70	200	14000	13	45	52
17000	13	84	142	16000	12	84	200	15000	12	82	92	15000	13	52	125
18000	13	100	154	17000	12	100	141	16000	12	85	125	16000	13	69	136
				18000	12	100	146	17000	12	87	164	17000	13	71	164
								18000	12	86	195	18000	13	68	184

TABLE 3-3. TYPICAL ANTENNA TUNING DATA (Continued)

DO NOT USE ANTENNA CAPACITOR

50 Ft. Antenna				55 Ft. Antenna				60 Ft. Antenna			
Type Airplane:				Type Airplane:				Type Airplane:			
_____				_____				_____			
_____				_____				_____			
_____				_____				_____			
KC	C	D	E	KC	C	D	E	KC	C	D	E
2100	1-2	...	0	2000	1-2	...	0	2000	1-2	...	0
2500	3-4	...	19	2500	3-4	...	15	2500	3-4	...	15
3000	4-5	...	55	3000	4-5	...	45	3000	5-6	...	55
3500	5-6	...	95	3500	5-6	...	100	3500	6-7	...	90
4000	6-7	...	120	4000	6-7	...	130	4000	7	...	125
5000	7	...	160	5000	7	100	168	4800	7	100	178
5500	7	...	100	5170	7	100	181				
5400	8	32	0	5000	8	15	0	4750	8	0	0
6000	8	38	90	6000	8	35	126	5000	8	4	60
7000	8	48	148	7000	8	51	152	6000	8	22	155
8000	8	65	152	8000	8	64	160	7000	8	44	170
9000	8	85	143	9000	8	81	136	8000	8	63	164
10000	8	92	142	9700	8	100	106	9000	8	80	150
								9700	8	100	120
9000	11	29	200	9500	9	62	198	8000	9	39	200
10000	11	40	200	10000	9	68	195	9000	9	58	200
11000	11	53	200	11000	9	87	171	10000	9	74	186
12000	11	72	200	11500	9	100	165	10880	9	100	123
13000	11	82	200								
14000	11	100	0	11200	10	73	200	10500	10	65	200
15000	11	98	135	12000	10	90	161	11000	10	78	181
				12200	10	100	82	11350	10	89	0
13500	13	37	28								
14000	13	45	52	12100	12	60	200	11290	11	74	200
15000	13	52	125	13000	12	62	133	12000	11	75	190
16000	13	69	136	14000	12	63	183				
17000	13	71	164	15000	12	68	200	11600	12	59	30
18000	13	68	184					12000	12	50	141
				14800	13	0	155	13000	12	49	197
				15000	13	0	160	15000	12	71	200
				16000	13	45	169	17000	12	85	200
				17000	13	62	177	18000	12	94	200
				18000	13	72	185				

TABLE 3-4. TYPICAL ANTENNA TUNING DATA

20 Ft. Antenna  
Type Airplane:

22.5 Ft. Antenna  
Type Airplane:

25 Ft. Antenna  
Type Airplane:

27.5 Ft. Antenna  
Type Airplane:

Use 75 mmfd capacitor  
(3 sections)

Use 75 mmfd capacitor  
(3 sections)

Use 75 mmfd capacitor  
(3 sections)

Use 75 mmfd capacitor  
(3 sections)

Freq.	C	D	E
2100	1	---	0
2500	3-4	---	0
3000	4-5	---	30
3500	5-6	---	52
4000	6	---	65
5000	6-7	---	102
6000	7	50	118
8000	7	72	146
10000	7	90	168
10500	7	100	174
10000	10	75	200
10500	10	85	200
11000	10	94	200
11300	10	100	200
11100	11	76	200
11600	11	95	200
11600	11	75	0
12000	11	75	80
13000	11	80	142
14000	11	86	180
15000	11	92	200
14500	13	0	164
15000	13	0	180
16000	13	66	185
17000	13	84	190
17700	13	100	200

Freq.	C	D	E
2100	1	---	0
2500	2-3	---	20
3000	4-5	---	45
3500	5-6	---	62
4000	6	---	80
5000	6-7	---	108
6000	7	48	120
7000	7	65	132
8000	7	76	149
10000	7	94	184
10400	7	100	200
10000	10	81	200
10450	10	100	200
10450	10	73	0
11000	10	76	75
12000	10	82	160
13000	10	88	178
14000	10	96	195
14100	10	100	200
14000	13	0	140
14500	13	0	175
15000	13	30	200
16000	13	67	200
17000	13	85	200
17600	13	100	200

Freq.	C	D	E
2160	1-2	---	0
2500	2-3	---	28
3000	4-5	---	50
3500	5-6	---	65
4000	6-7	---	80
5000	6-7	---	106
6000	7	44	125
7000	7	64	140
9000	7	80	184
9500	7	90	200
9500	10	65	0
10000	10	66	92
11000	10	68	166
12000	10	74	184
13000	10	82	192
14000	10	90	200
14500	10	100	200
14400	13	0	162
14500	13	0	164
15000	13	0	181
16000	13	51	200
17000	13	73	200
18000	13	89	200

Freq.	C	D	E
2130	1-2	---	0
2500	2-3	---	20
3000	4-5	---	44
3500	5-6	---	65
4000	6	---	85
5000	6-7	---	116
6000	7	52	138
7000	7	65	154
8000	7	75	174
8800	7	86	200
8800	10	58	0
9000	10	59	40
10000	10	62	156
11000	10	63	191
12000	10	75	200
13000	10	84	200
14000	10	92	200
14400	10	100	200
13000	11	76	200
14000	11	85	200
15000	11	94	200
15600	11	100	200
14400	13	0	161
15000	13	0	186
16000	13	56	200
17000	13	76	200
18000	13	90	200

USE THESE DATA ONLY IF ONE OR MORE CHANNELS IS BETWEEN 2000 AND 3000 KCS.

USE THESE DATA ONLY IF ONE OR MORE CHANNELS IS BETWEEN 2000 AND 2700 KCS.

TABLE 3-4. TYPICAL ANTENNA TUNING DATA (Continued)

27.5 Ft. Antenna				30 Ft. Antenna				32.5 Ft. Antenna				35 Ft. Antenna			
Type Airplane:				Type Airplane:				Type Airplane:				Type Airplane:			
Use 75 mmfd capacitor (3 sections)				Use 75 mmfd capacitor (3 sections)				Use 50 mmfd capacitor (2 sections)				Use 50 mmfd capacitor (2 sections)			
Freq.	C	D	E	Freq.	C	D	E	Freq.	C	D	E	Freq.	C	D	E
2130	1-2	---	0	2100	1	---	0	2100	1-2	---	0	2150	1	---	0
2500	2-3	---	20	2500	2-3	---	30	2500	3-4	---	10	2500	2-3	---	22
3000	4-5	---	44	3000	4-5	---	48	3000	3-4	---	44	3000	4-5	---	60
3500	5-6	---	65	3500	5-6	---	64	3500	5-6	---	70	3500	5-6	---	85
4000	6	---	85	4000	6	---	80	4000	6-7	---	90	4000	6-7	---	110
5000	6-7	---	116	5000	6-7	---	121	5000	7	---	124	5000	7	32	128
6000	7	52	138	6000	7	54	138	6000	7	55	144	6000	7	56	156
7000	7	65	154	7000	7	71	152	7000	7	70	173	7000	7	75	184
8000	7	75	174	8000	7	81	186	7790	7	90	200	7435	7	95	200
8800	7	86	200	8350	7	100	200								
								7650	9	60	0	7200	9	54	0
8800	10	58	0	8100	10	50	0	8000	9	64	60	7500	9	58	49
9000	10	59	40	8500	10	50	88	9000	9	69	112	8000	9	60	112
10000	10	62	156	9000	10	52	138	10000	9	74	169	9000	9	67	142
11000	10	63	191	10000	10	55	165	11000	9	81	179	10000	9	72	160
12000	10	75	200	11000	10	66	200	12000	9	90	179	11000	9	80	176
13000	10	84	200	12000	10	76	200	12500	9	100	180	12000	9	88	178
14000	10	92	200	13000	10	85	200					13000	9	100	181
14400	10	100	200	13500	10	89	200	11000	10	69	200				
				14000	10	93	200	12000	10	78	200	10000	10	53	200
13000	11	76	200					13000	10	86	200	11000	10	65	200
14000	11	85	200	13500	11	81	200	14000	10	95	200	12000	10	74	200
15000	11	94	200	14000	11	85	200	14100	10	100	200	13000	10	82	200
15600	11	100	200	14500	11	89	200					14000	10	90	200
				15000	11	93	200	13000	11	79	200	14600	10	100	200
14400	13	0	161					14000	11	86	200				
15000	13	0	186	14800	13	0	180	15000	11	94	200	14500	13	0	160
16000	13	56	200	15000	13	0	188	15300	11	100	200	15000	13	0	178
17000	13	76	200	15500	13	41	200					16000	13	70	156
18000	13	90	200	16000	13	58	200	15000	13	5	200	17000	13	90	130
				17000	13	76	200	16000	13	60	200	17700	13	100	146
				18000	13	91	200	17000	13	86	164				
								18000	13	100	185				

USE THESE DATA ONLY IF ONE OR MORE CHANNELS IS BETWEEN 2000 AND 2600 KCS.

USE THESE DATA ONLY IF ONE OR MORE CHANNELS IS BETWEEN 2000 AND 2400 KCS.

TABLE 3-4. TYPICAL ANTENNA TUNING DATA (Continued)

35 Ft. Antenna				40 Ft. Antenna				45 Ft. Antenna				50 Ft. Antenna			
Type Airplane:				Type Airplane:				Type Airplane:				Type Airplane:			
Use 50 mmfd capacitor (2 sections)				Use 50 mmfd capacitor (2 sections)				Use 25 mmfd capacitor (1 section)				Use 25 mmfd capacitor (1 section)			
Freq.	C	D	E	Freq.	C	D	E	Freq.	C	D	E	Freq.	C	D	E
2150	1	—	0	2100	1-2	—	0	2050	1-2	—	0	2050	1-2	—	0
2500	2-3	—	22	2500	3-4	—	25	2500	3-4	—	33	2500	3-4	—	33
3000	4-5	—	60	3000	4-5	—	66	3000	4-5	—	70	3000	4-5	—	70
3500	5-6	—	85	3500	5-6	—	100	3500	5-6	—	111	3500	5-6	—	111
4000	6-7	—	110	4000	6-7	—	120	4000	6	—	132	4000	6	—	132
5000	7	32	128	5000	7	38	144	5000	7	43	160	5000	7	43	160
6000	7	56	156	6000	7	60	179	5500	7	54	180	5500	7	54	180
7000	7	75	184	6500	7	71	200	5900	7	60	200	5900	7	60	200
7435	7	95	200												
				6330	9	40	0	5800	9	27	0	5800	9	27	0
7200	9	54	0	7000	9	47	94	6000	9	30	42	6000	9	30	42
7500	9	58	49	8000	9	56	148	7000	9	42	138	7000	9	42	138
8000	9	60	112	9000	9	66	162	8000	9	55	158	8000	9	55	158
9000	9	67	142	10000	9	72	174	9000	9	67	165	9000	9	67	165
10000	9	72	160	11000	9	80	177	10000	9	74	170	10000	9	74	170
11000	9	80	176	12000	9	91	178	11000	9	83	173	11000	9	83	173
12000	9	88	178	12600	9	100	179	12000	9	100	150	12000	9	100	150
13000	9	100	181					12200	9	100	173	12200	9	100	173
				11000	10	68	200								
10000	10	53	200	12000	10	76	200	12000	11	70	200	12000	11	70	200
11000	10	65	200	13000	10	85	200	13000	11	80	200	13000	11	80	200
12000	10	74	200	14000	10	100	180	14000	11	91	158	14000	11	91	158
13000	10	82	200	14190	10	100	192	14400	11	100	110	14400	11	100	110
14000	10	90	200												
14600	10	100	200	14000	12	71	200	14000	12	75	200	14000	12	75	200
				14500	12	75	200	15000	12	82	75	15000	12	82	75
14500	13	0	160	15000	12	80	200	16000	12	85	143	16000	12	85	143
15000	13	0	178	16000	12	88	150	17000	12	89	174	17000	12	89	174
16000	13	70	156	17000	12	94	108	18000	12	92	200	18000	12	92	200
17000	13	90	130	18000	12	100	157								
17700	13	100	146												

USE THESE DATA ONLY IF ONE OR MORE CHANNELS IS BETWEEN 2000 AND 2400 KCS.

USE THESE DATA ONLY IF ONE OR MORE CHANNELS IS BETWEEN 2000 AND 2200 KCS.

## SECTION IV

### THEORY OF OPERATION

#### 1. POWER CONTROL CIRCUITS.

*a.* Primary power for application to the dynamotor is controlled by contactors located in the Type DY-12/ART-13 Power Unit. All relays and contactors in the equipment, except K2103, K2104, and K2106, operate from the 28 volt dc power source. Relays K2103 and K2104 are thermal-operated overload relays which serve to protect the equipment from damage due to overloads. Relay K2106 is a pressure-operated switch and requires no voltage for operation. This relay will operate when the atmospheric pressure has been reduced to the pressure at an altitude of approximately 25,000 feet above sea level. Complete control of all power contactors is possible from either the panel or the remote position.

*b.* Figure 4-1. shows a simplified schematic of the power control circuits.

*c.* Relays K2103 and K2104 are normally closed and operate to break the primary circuits when an overload occurs. These relays may be returned to the normal position by pressing the RESET buttons located on the Power Control Unit. Primary overload relay K2103 is designated as TRANSMITTER RESET and dynamotor overload relay K2104 as DYNAMOTOR RESET. With the overload relays K2103 and K2104 in normally closed positions and the LOCAL-REMOTE switch, S107, in the LOCAL position, placing the EMISSION selector switch, S110, in the VOICE position will complete the circuit necessary for the operation of the primary power contactor K2102. The primary power contactor coil is energized by the circuit through LOCAL-REMOTE switch S107, EMISSION selector switch S110, the primary power contactor coil and the contacts of primary overload relay K2103. When the power control relay, K2102, has operated, the circuit necessary for the operation of the "voice" relay, K104, is completed through the contacts of primary overload relay K2103, the contacts of primary power contactor K2102, the coil of "voice" relay K104, the contacts of EMISSION selector switch S110, and the contacts of LOCAL-REMOTE switch S107. If the power level switch, S106, is in either the TUNE or OPERATE position, it is necessary to operate the TEST switch, S104, or

to complete the circuit through the throttle switch jack, J101, MICROPHONE jack J102, or KEY jack J103, before the dynamotor input relay, K2101, will operate.

*d.* Operating the EMISSION selector switch, S110, to the CW position completes the circuit necessary for the operation of CW relay K103, through the contacts of LOCAL-REMOTE switch S107, EMISSION selector switch S110, and the coil of CW relay K103. When the CW relay, K103, has operated, the coil of dynamotor input relay K2101 is energized through contacts 4 and 5 of CW relay, K103, the coil of dynamotor input relay K2101, the contacts of AUTOTUNE limit switch section S111, contacts 1 and 3 of motor control relay K101, the contacts of primary power contactor K2102, and the normally closed contacts of overload relay K2103.

*e.* If the EMISSION selector switch, S110, is operated to the MCW position, the primary power contactor, K2102, is operated by the circuit through the normally closed contacts of overload relay K2103, the coil of primary power contactor K2102, the contacts of EMISSION selector switch S110, and the contacts of LOCAL-REMOTE switch S107. Dynamotor input relay K2101 is energized by the current through the normally closed contacts of primary overload relay K2103, the contacts of primary power contactor K2102, contacts 1 and 3 of motor control relay K101, the contacts of Autotune limit switch section S111, the coil of dynamotor input relay K2101, the contacts of EMISSION selector switch S110, and the contacts of LOCAL-REMOTE switch S107. The operation of dynamotor input relay K2101 closes the contacts of this relay and applies power to the motor section of dynamotor D2101 through the normally closed contacts of dynamotor overload relay K2104.

*f.* If the power level switch, S106, is operated to the CALIBRATE position, CW relay K103 is energized by the current through the normally closed contacts of primary overload relay K2103, the contacts of primary power contactor K2102, the coil of CW relay K103 and the contacts of power level switch S106. The dynamotor input relay, K2101, is energized by the current through

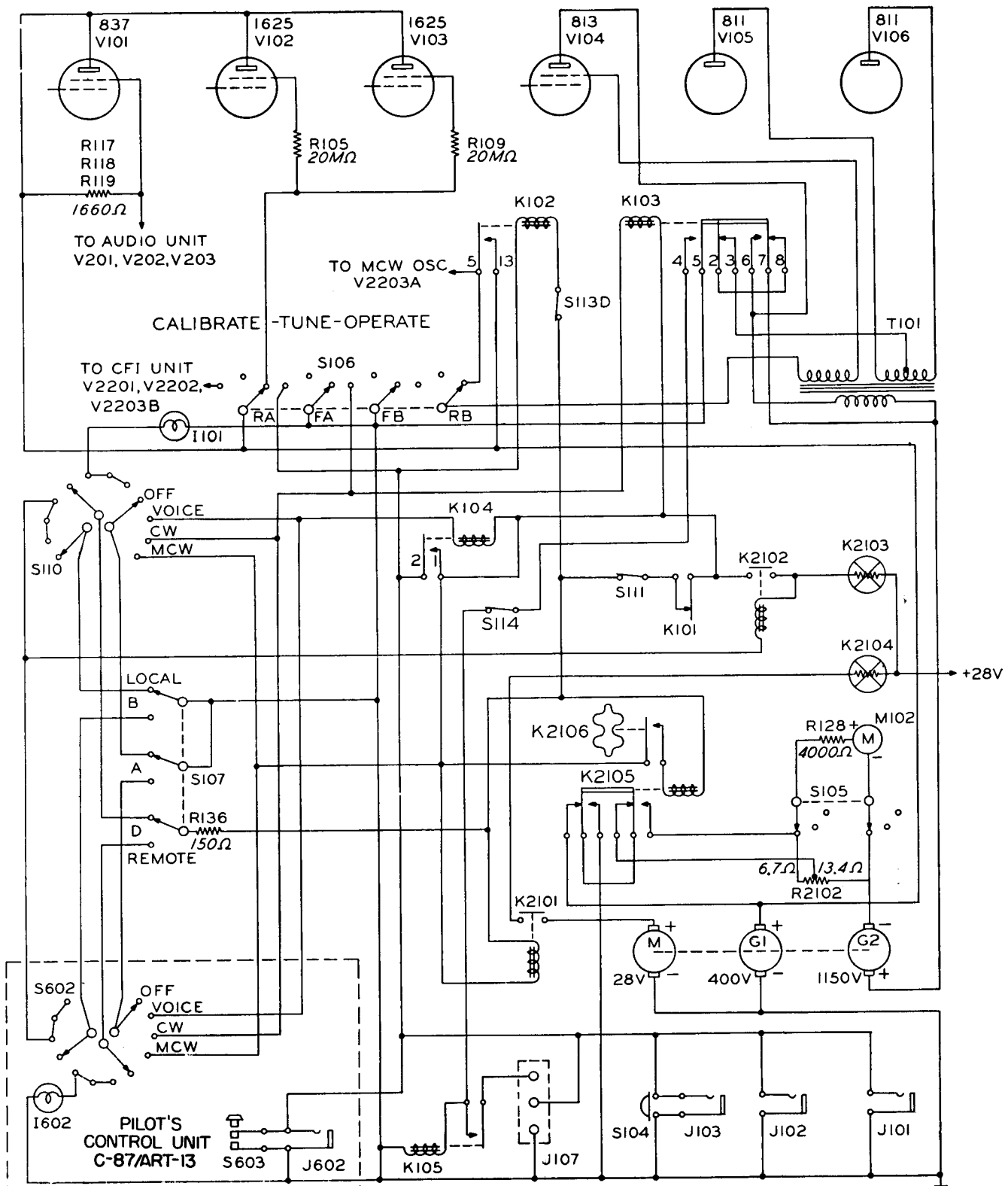

I602, J602 AND S603 ARE NOT INCLUDED IN THE C-740/ART-13 PILOT'S CONTROL UNIT, WHICH MAY BE USED IN PLACE OF THE C-87/ART-13.

Figure 4-1. Power Control Circuits



the normally closed contacts of primary overload relay K2103, the contacts of primary power contactor K2102, contacts 1 and 3 of Autotune motor control relay K101, the contacts of Autotune limit switch section S111, the coil of dynamotor input relay K2101, and contacts 4 and 5 of CW relay K103.

g. With LOCAL-REMOTE switch S107 in the LOCAL position the primary power contactor, K2102, and the transmitter panel pilot lamp, I101, will be lighted when the EMISSION selector switch, S110, is in any position other than the OFF position. Primary power contactor K2102 will be energized by the current through the normally closed contacts of primary overload relay K2103, the coil of primary power contactor K2102, the contacts of EMISSION selector switch S110, and the contacts of LOCAL-REMOTE switch S107. The pilot lamp, I101, will be lighted through the normally closed contacts of primary overload relay K2103, the contacts of primary power contactor K2102, contacts 1 and 3 of Autotune motor control relay K101, the contacts of Autotune limit switch section S111, the pilot lamp series resistor, R136, the contacts of LOCAL-REMOTE switch S107 and the contacts of EMISSION selector switch S110.

h. When the LOCAL-REMOTE switch, S107, is placed in the REMOTE position, control of all power circuits is transferred from the transmitter panel controls to the controls located on the pilot's control unit or the console control panel.

i. If the emission selector switch, S602, is placed in the VOICE position, the primary power contactor, K2102, is energized by the circuit through the normally closed contacts of primary overload relay K2103, the coil of primary power contactor K2102, the contacts of emission selector switch S602, and the contacts of LOCAL-REMOTE switch S107. To complete the circuit necessary for the operation of the dynamotor input relay, K2101, the telegraph key, S603, must be operated or the microphone jack, J602, circuit must be completed. The "voice" relay, K104, is energized by the current through the normally closed contacts of primary overload relay K2103, the contacts of primary power contactor K2102, the coil of "voice" relay K104, the contacts of emission selector switch S602, and the contacts of LOCAL-REMOTE switch S107. The dynamotor input relay, K2101, is energized by the current through the normally closed contacts of primary overload relay K2103, the contacts of primary power contactor K2102,

contacts 1 and 3 of Autotune motor control relay K101, the contacts of Autotune limit switch section S111, the coil of dynamotor input relay K2101, contacts 1 and 2 of "voice" relay K104 and telegraph key S603 or microphone jack J602.

j. When the emission selector switch, S602, is operated to the CW position, the CW relay, K103, is energized by the current through the normally closed contacts of primary overload relay K2103, the contacts of primary power contactor K2102, the coil of CW relay K103, the contacts of emission selector switch S602 and the contacts of LOCAL-REMOTE switch S107. The operation of CW relay K103 completes the circuit necessary for the operation of dynamotor input relay K2101. Dynamotor input relay K2101 is operated by the circuit through the normally closed contacts of primary overload relay K2103, the contacts of primary power contactor K2102, contacts 1 and 3 of Autotune motor control relay K101, the contacts of Autotune limit switch section S111, the coil of dynamotor input relay K2101 and contacts 4 and 5 of CW relay K103. The operation of the dynamotor input relay, K2101, applies power to the motor section of dynamotor D2101 through the normally closed contacts of dynamotor overload relay K2104 and the contacts of dynamotor input relay K2101.

k. If the emission selector switch, S602, is operated to the MCW position, primary power contactor K2102 is held operated and dynamotor input relay K2101 is energized through the normally closed contacts of primary overload relay K2103, the contacts of primary power contactor K2102, contacts 1 and 3 of Autotune motor control relay K101, the contacts of Autotune limit switch section S111, the coil of dynamotor input relay K2101, the contacts of emission selector switch S602 and the contacts of LOCAL-REMOTE switch S107.

l. With LOCAL-REMOTE switch S107 in the REMOTE position the primary power contactor, K2102, and the pilot lamp, I601, are energized when emission selector switch S602 is in any position other than the OFF position. Primary power contactor K2102 is energized through the normally closed contacts of primary overload relay K2103, the coil of primary power contactor K2102, the contacts of emission selector switch S602 and the contacts of LOCAL-REMOTE switch S107. The pilot lamp, I601, is energized by the circuit through the normally closed contacts of primary overload relay K2103, the contacts of primary power contactor K2102, contacts 1 and 3 of Autotune motor control relay K101, the con-

tacts of Autotune limit switch section S111, pilot lamp series resistor R136, the contacts of LOCAL-REMOTE switch S107 and the contacts of emission selector switch S602.

*m.* The power change relay, K2105, operates when the pressure is reduced to that at an altitude of approximately 25,000 feet above sea level by the operation of the pressure operated relay, K2106. If the transmitter is operating with VOICE emission, the coil of power change relay K2105 is energized by the circuit through the normally closed contacts of primary overload relay K2103, the contacts of primary power contactor K2102, contacts 1 and 3 of Autotune motor control relay K101, the contacts of Autotune limit switch section S111, the coil of power change relay K2105, the contacts of pressure operated relay K2106, the contacts of "voice" relay K104 and the closed circuit of MICROPHONE jack J102. If the transmitter is operating with CW emission and pressure operated relay K2106 has operated, the operating circuit for power change relay K2105 is through the normally closed contacts of primary overload relay K2103, the contacts of primary power contactor K2102, contacts 1 and 3 of Autotune motor control relay K101, the contacts of Autotune limit switch section S111, the coil of power change relay K2105, the contacts of pressure operated relay K2106 and contacts 4 and 5 of CW relay K103. If the transmitter is operating with MCW emission, the energizing circuit for

power change relay K2105 is through the normally closed contacts of primary overload relay K2103, the contacts of primary power contactor K2102, contacts 1 and 3 of Autotune motor control relay K101, the contacts of Autotune limit switch section S111, the coil of power change relay K2105, the contacts of pressure operated relay K2106, the contacts of EMISSION selector switch S110 or the contacts of emission selector switch S602 and the contacts of LOCAL-REMOTE switch S107.

**2. FILAMENT CIRCUITS.**

*a.* The filament power circuits of the transmitter are a combination of series and parallel connections. Power is from the 28 volt dc source. Figure 4-2. shows the filament connections in simplified form. All filament power is controlled by the contacts of primary power contactor K2102. The primary overload relay, K2103, operates to break the circuit when an overload occurs in the filament or associated circuits.

**3. HIGH VOLTAGE CIRCUITS.**

*a.* Figure 4-3. shows, in simplified form, the high voltage circuits employed in the equipment.

*b.* The dynamotor employs an armature with dual windings and two commutators to give output voltages of 400 volts dc and 750 volts dc. To obtain the high voltages necessary for application to the power amplifier and modulator tubes, the 400 volt output is connected in series with the 750 volt output of the dynamotor. On the dia-

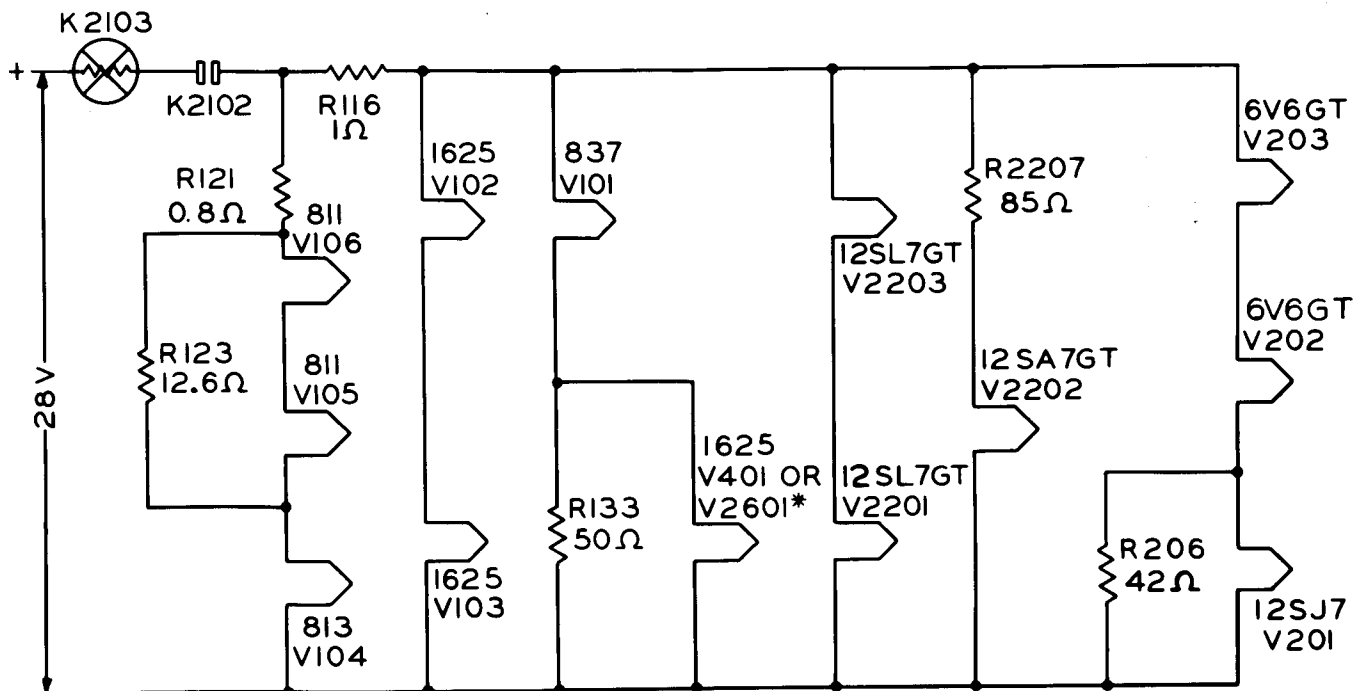

Figure 4-2. Filament Circuits

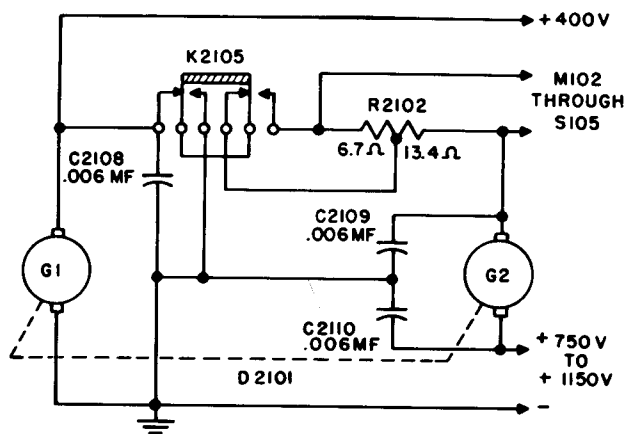

Figure 4-3. High Voltage Circuits

grams, figure 4-3., figure 8-13. page 8-23, figure 8-14. page 8-23, figure 8-15. page 8-24, the low voltage section of the dynamotor is designated as G1 and the high voltage section is designated as G2. When the power change relay, K2105, is in the normal position the positive lead from low voltage dynamotor section G1 is connected to the negative lead of high voltage dynamotor section G2 through the contacts of power change relay K2105, and milliammeter multiple resistor R2102. As explained in paragraph *m.*, the circuit necessary to energize the coil of power change relay K2105 is completed by the operation of the pressure-operated relay, K2106. When power change relay K2105 operates, the negative lead of high voltage dynamotor section G2 is disconnected

from the positive lead of low voltage dynamotor section G1 and is grounded through milliammeter multiple resistor R2102 and the contacts of power change relay K2105. Spark suppressing circuits have been incorporated in the output circuits of the dynamotor, to suppress sparks generated at the motor and generator brushes.

4. EMISSION SELECTION AND CONTROL.

(Refer to figure 4-4.)

a. The EMISSION selector switch S110 is a combination transmitter ON-OFF switch and EMISSION selector switch. Operating EMISSION selector switch S110 to the VOICE, CW or MCW position will operate the primary power contactor K2102.

Note

Refer to paragraph 1. for detailed explanation of the operation of primary power contactor K2102.

Selecting VOICE emission by the operation of EMISSION selector switch S110 operates "voice" relay K104. Contacts 5 and 6 of "Voice" relay K104 disconnect the output of the MCW oscillator tube, V2203A, from the input to the speech amplifier. Contacts 1 and 2 of "Voice" relay K104 connect the coil of dynamotor input relay K2101 to the emission control circuits of throttle switch jack J101, MICROPHONE jack J102, KEY jack J103 and the TEST switch, S104. Selecting CW emission completes the circuit necessary for the

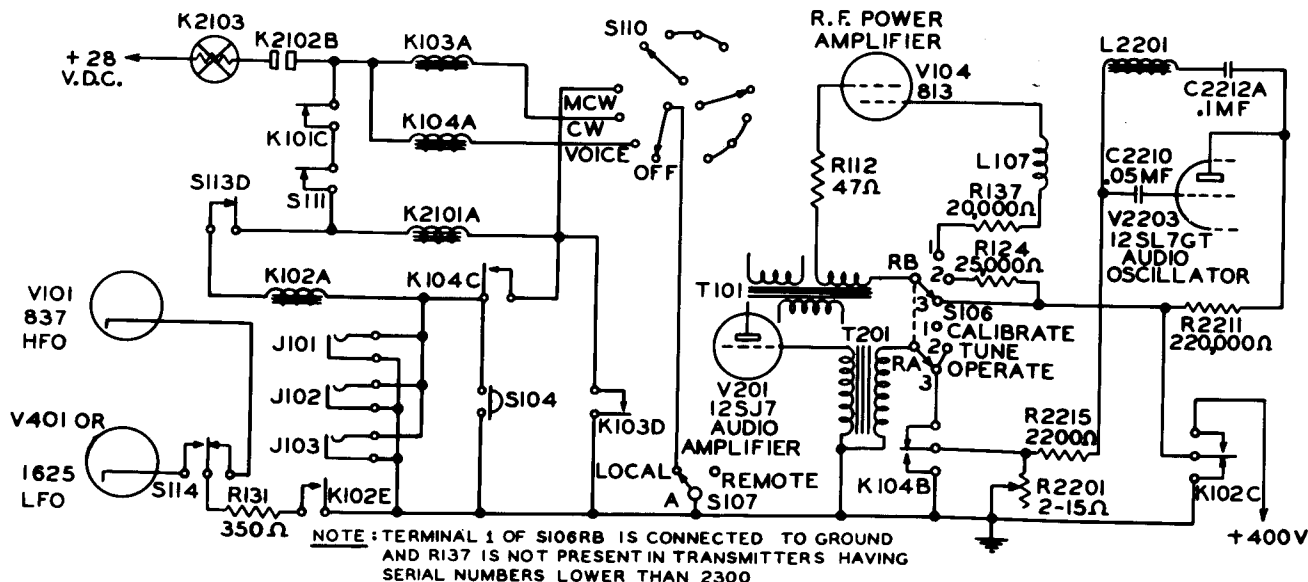

Figure 4-4. Emission Selection and Control Circuits

operation of CW relay K103. Contacts 4 and 5 of CW relay K103 complete the circuit necessary for the operation of dynamotor input relay K2101 which, in turn, applies primary power to the dynamotor, D2101. Selecting MCW emission operates dynamotor input relay K2101 directly.

b. The RF carrier is keyed by closing the cathode circuit of the oscillator and applying the screen voltage from the power amplifier. The keying relay, K102, has six sets of contacts. Refer to figure 5-17, page 5-44 for contact designation of this relay. Keying relay contacts 3 and 9 complete the oscillator cathode circuit by grounding resistor R131. Keying relay contacts 3 and 9 and resistor R131 serve as a cathode return for both the HF oscillator tube, V101, and the LF oscillator tube, V401 or V2601. The desired oscillator circuit is selected by the operation of oscillator selecting switch S114 which is cam operated in conjunction with Control "A". The MCW oscillator tube, V2203A, is in operation whenever keying relay K102 is in the *operated* position. The voltage developed across the resistor, R2201, is applied to the input of the speech amplifier through contacts 5 and 6 of "voice" relay K104, the contacts of power level switch, S106 and the input transformer, T201. Keying relay contacts 5 and 13 apply plate voltage to MCW oscillator tube V2203A. During periods of CW transmission the output of the MCW oscillator is fed through the speech amplifier to the sidetone amplifier and the keying may be monitored by listening to the output of the sidetone amplifier. When power level switch S106 is in the CALIBRATE position, the circuit from the output of the MCW oscillator to the input of the speech amplifier is broken. The keying relay, K102, may be operated by closing the circuits of the Throttle Switch jack J101, the MICRO-

PHONE jack, J102, or the KEY jack, J103, or by operating the TEST switch, S104. Keying interlock switch S113D is operated in conjunction with output network switch, S113 (actuated by Control "C") and breaks the energizing circuit to the coil of keying relay K102 when output network switch S113 is operated, thus removing excitation from the RF circuits to prevent arcing at the switch contacts. The Autotune limit switch section, S111, and contacts 1 and 3 of Autotune motor control relay K101 are also connected in series with the coil of keying relay K102 so that when Autotune Limit switch section S111 or Autotune motor control relay K101 operates, the holding circuit for keying relay K102 will be broken and arcing at all switch contacts will be prevented.

### 5. AUDIO CIRCUITS

The audio system consists of a two stage speech amplifier, push-pull modulators, a sidetone amplifier, and an MCW audio tone oscillator. Refer to figure 4-5. and 4-6.

a. SPEECH AMPLIFIER.—Either of two types of microphones may be used with this equipment. By operating microphone circuit selector switch S201, proper connections are made to the MICROPHONE jack, J102, (*figure 4-5.*) to match the output of either a carbon or dynamic type of microphone. This switch is located beneath the tuning chart on the front panel of the transmitter. If microphone circuit selector switch S201 is placed in the CARBON position, the bleeder composed of R201, R202, R203, and R204 connected between the positive terminal of the 28 volt DC power source and ground provides the voltage necessary for the operation of the carbon type of microphone. The operation of microphone circuit selector switch S201 also connects limiting resistor

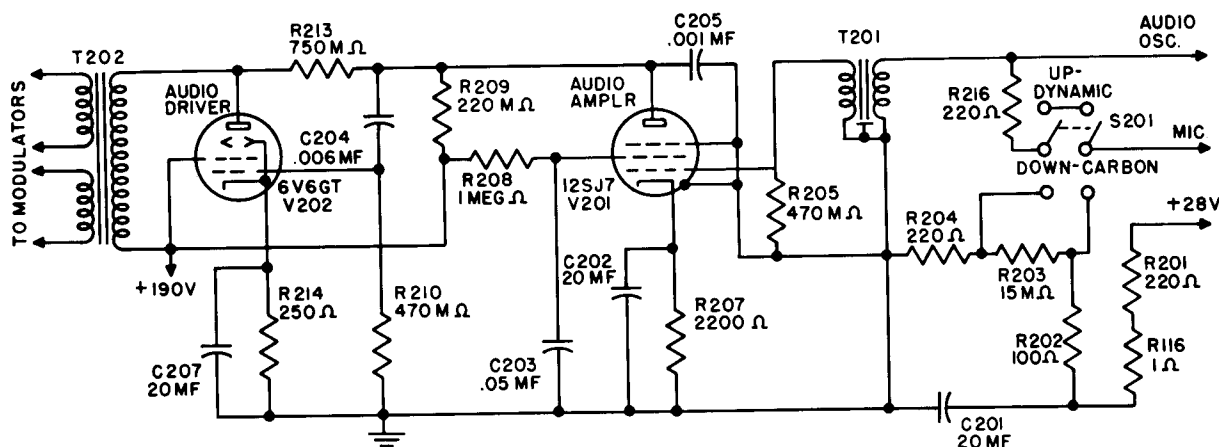

Figure 4-5. Speech Amplifier Circuit

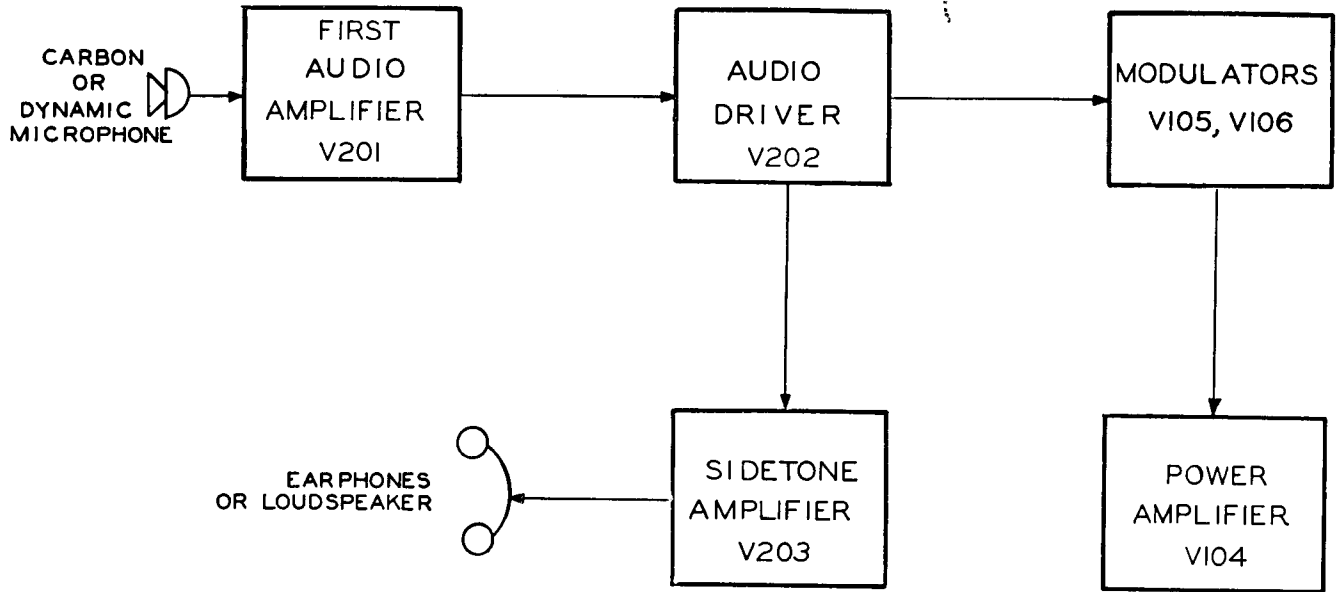

Figure 4-6. Audio Circuits Block Diagram

R203 between MICROPHONE jack J102 and the input circuit of the speech amplifier reducing the level of the output of the carbon microphone to the level of the output of a dynamic microphone. Thus, no audio gain control has been provided because the level of the input to the speech amplifier is the same when using a dynamic microphone as it is when using a carbon microphone. If microphone circuit selector switch S201 is placed in the DYNAMIC position, the voltage is removed from the input circuit and the MICROPHONE jack, J102, is connected in series with limiting resistor R216 and the primary of the input transformer, T201. The two stage speech amplifier employs a Type 12SJ7 FIRST AUDIO AMPLIFIER tube, V201 and a Type 6V6GT audio driver tube, V202. The output of the microphone is coupled by the input transformer, T201, to the

grid of FIRST AUDIO AMPLIFIER tube V201. The output of FIRST AUDIO AMPLIFIER tube V201 is coupled to the grid of audio driver tube V202 by the capacitor C204. The output of audio driver tube V202 is coupled to the grids of the modulator tubes, V105 and V106, by driver transformer T202.

b. MODULATOR.—The modulator (figure 4-7.) employs two Type 811 high mu triodes connected in push-pull, and operating Class B. The modulators are capable of modulating the carrier (100 watts nominal) at least 90% with full voltage applied to the power amplifier. While the 811 is essentially a zero bias tube when used with plate voltages as high as 1150 volts dc, it becomes necessary to apply some bias to the grid of the tube to keep the static plate current as low as practicable. In this application the bias is obtained

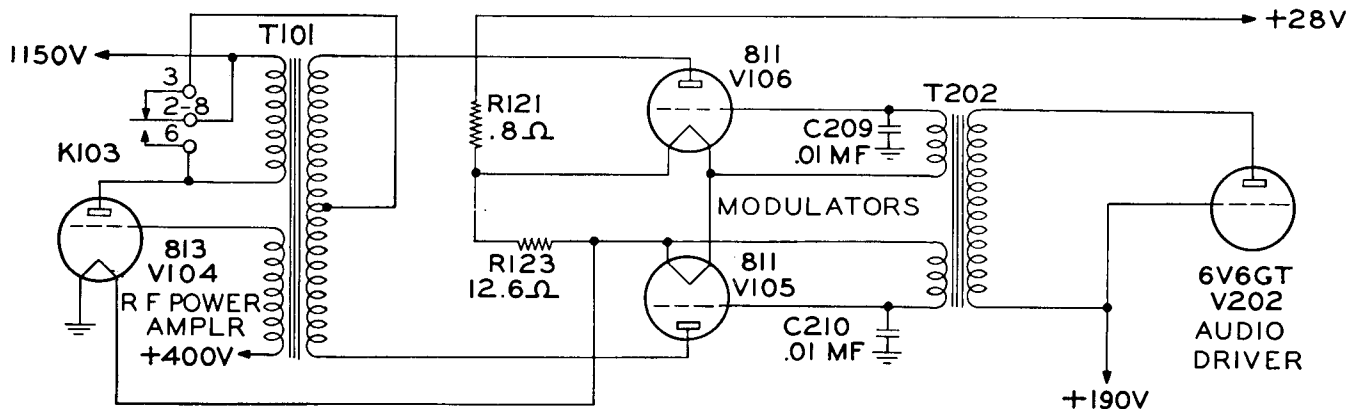

Figure 4-7. Modulator Circuit

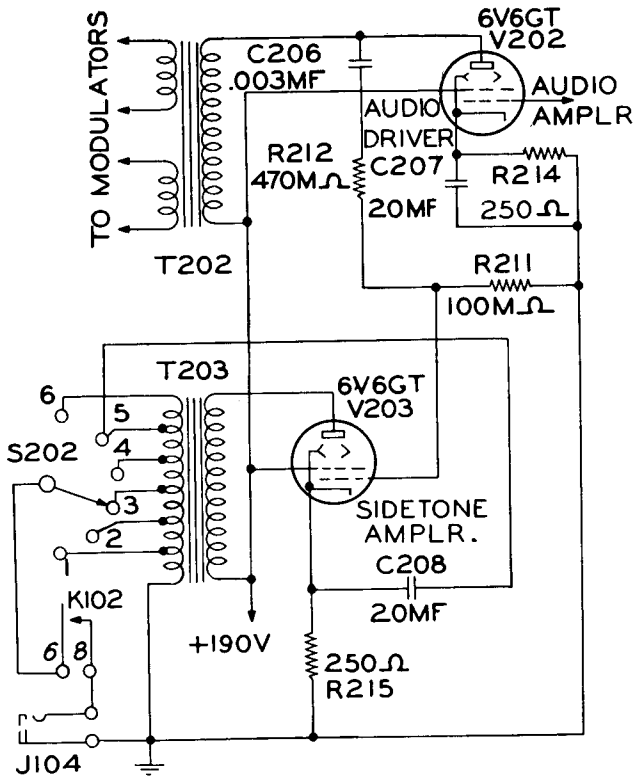

Figure 4-8. Sidetone Amplifier Circuit

from the 28 volt dc supply by utilizing the average voltage drop through the filaments of the tubes to obtain equal voltage for application to the grids of both modulator tubes. The output of the modulators is coupled to the RF circuit by modulation

transformer T101. Both the screen and plate of the final amplifier tube, V104, are modulated. The full output voltage of the dynamotor, 1150 volts DC, is applied to the plates of the modulator tubes, V105 and V106. When emission selector switch S110 is positioned on CW, CW relay K103 is actuated, removing plate voltage from the modulators and shorting the plate modulation section of the modulation transformer secondary.

c. SIDETONE AMPLIFIER.—A sidetone amplifier is incorporated in the same unit as the two stage speech amplifier. Refer to figure 4-8. This amplifier employs a Type 6V6GT beam pentode tube, V203. The output of the audio driver tube, V202, in addition to being applied to the primary of driver transformer T202, is applied to a voltage divider system consisting of C206, R211 and R212. The grid of the sidetone amplifier tube, V203, is coupled to the junction of R211 and R212 and the voltage developed across resistor R211 drives the grid of V203 to provide sufficient output from the sidetone amplifier to operate headphones or speaker. The output of sidetone amplifier tube V203 is coupled to the SIDETONE jack, J104, by SIDETONE impedance matching transformer T203 through sidetone amplifier OUTPUT control switch S202 and contacts 6 and 8 of keying relay K102. The turns-ratio of SIDETONE impedance matching transformer T203 may be varied by operating the sidetone OUTPUT switch S202. The output of the sidetone amplifier is keyed by the

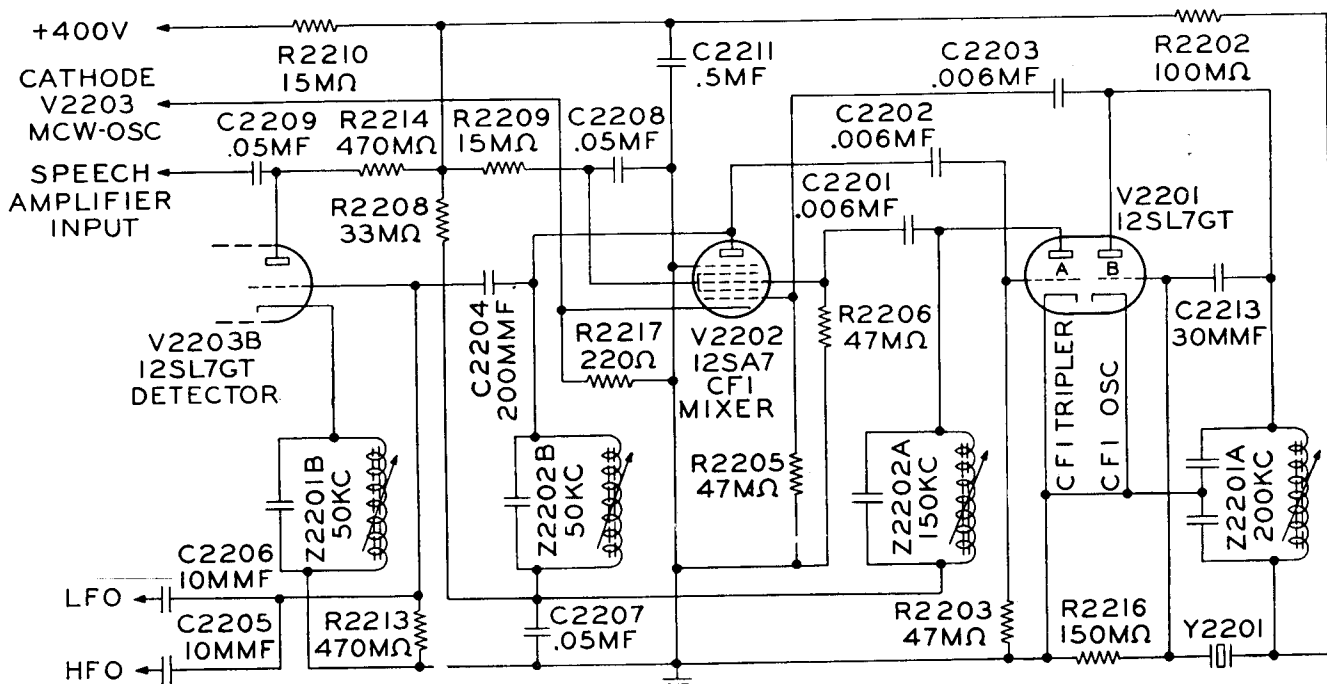

Figure 4-9. CFI Circuit

operation of keying relay K102. The SIDETONE jack, J104, may be connected in parallel with auxiliary jack J105 by connecting a jumper between terminals 26 and 27 of cable connector J106. The necessary plate and screen voltages for the sidetone amplifier are obtained by tapping the bleeder system of the low voltage output of the dynamotor.

#### d. CALIBRATION OSCILLATOR.

(1) GENERAL.—The calibration oscillator employs a circuit known as a regenerative frequency divider. Refer to figure 4-9. The circuit produces a 50 kc fundamental frequency and harmonic output voltages while using a 200 kc crystal as a controlling standard. The 200 kc quartz crystal unit is mounted in a sealed holder which plugs into a two terminal socket on the top of the chassis. Both triode sections of a 12SL7GT tube, V2201, a 12SA7 pentagrid converter tube, V2202, and one section of an additional 12SL7GT tube, V2203, are used in the calibration oscillator circuit. The vacuum tubes plug into octal sockets on top of the chassis in the order mentioned. The chassis is stamped with the crystal and vacuum tube type designations. The inductor tuning screws that protrude through the sides of the shield cans containing tank circuits Z2201A, Z2201B, Z2202A, and Z2202B should not be adjusted for any reason unless the alignment procedure is thoroughly understood. The CFI Unit is placed in operation by applying plate voltage to the CFI tubes. The voltage is obtained from the low voltage section of the dynamotor and is applied when power level switch S106 is operated to the CALIBRATE position. Operating power level switch S106 to either TUNE or OPERATE position removes high voltage from the CFI tubes thus disabling the oscillator circuit.

#### (2) CIRCUIT FUNCTION.

(a) The application of plate voltage to the oscillator section of 12SL7GT tube V2201, starts the 200 kc crystal oscillator. This causes a frequency of 200 kc, plus random tube and circuit noises, to appear on the injection grid of 12SA7 mixer tube V2202. This random noise appearing on the plate of 12SA7 excites the frequency tripler section of 12SL7GT tube V2201. Since the plate circuit of this section of 12SL7GT tube V2201 is tuned to 150 kc, only the 150 kc components of the random noise are amplified. This 150 kc component of the random noise is then impressed on the control grid of the 12SA7 mixer tube. Since the plate circuit of the 12SA7 is tuned to 50 kc; the

50 kc difference frequency, produced by the combination of a 200 kc voltage and a 150 kc voltage appearing in the 12SA7 tube, is the frequency amplifier. This 50 kc voltage continues to excite the second triode section of the 12SL7GT, which because of its 150 kc plate circuit, triples the frequency and sustains the 150 kc voltage on the 12SA7 control grid. The 50 kc voltage appearing on the 12SA7 plate becomes the calibration frequency.

(b) One triode section of the second 12SL7GT tube, V2203, is employed as a signal detector. A portion of the 50 kc voltage appearing on the plate of 12SA7 tube V2202 is coupled to the grid of V2203 by capacitor C2204. Depending upon the transmitting frequency that is selected, a portion of the output of the LF oscillator or the HF oscillator is coupled to the grid of V2203 by capacitor C2206 or capacitor C2205. The beat note that is generated in the signal detector between the output of the HF or the LF oscillator and the 50 kc CFI standard is coupled to the input of the speech amplifier by capacitor C2209. When power level switch S106 is operated to the CALIBRATE position the circuit is completed and the output of the signal detector is heard in the sidetone circuits of the transmitter. The second triode section of 12SL7GT tube V2203 is connected as an audio oscillator which supplies a signal for sidetone keying and MCW operation of the transmitter. The 12SA7 CFI mixer tube V2202 and the audio oscillator section of 12SL7GT tube V2203 are provided with a common bias resistor, R2217. When the CFI is turned off, the voltage drop across R2217 is not sufficient to stop the audio oscillator. However, when the CFI is operating, 12SA7 CFI mixer tube V2202 draws sufficient current to cause a sharp increase in the voltage drop across R2217 increasing the bias voltage applied to the cathode of the audio oscillator section of 12SL7GT tube V2203. This results in overbiasing and stopping the audio oscillator tube which prevents the CFI detector from accepting a portion of the 1000 cycle voltage, generated by the audio oscillator, through capacity coupling between the 12SL7GT tube elements. Refer to figure 4-11.

e. MCW AUDIO OSCILLATOR.—Contacts 5 and 13 of keying relay K102 apply voltage to the plate of the audio oscillator section of 12SL7GT tube V2203 when keying relay K102 is operated. Refer to figure 4-10. The audio frequency output level of this oscillator and consequently the percentage of MCW modulation is controlled by varying resistor R2201. The screwdriver slot for varying resistor R2201 is accessible through a hole on

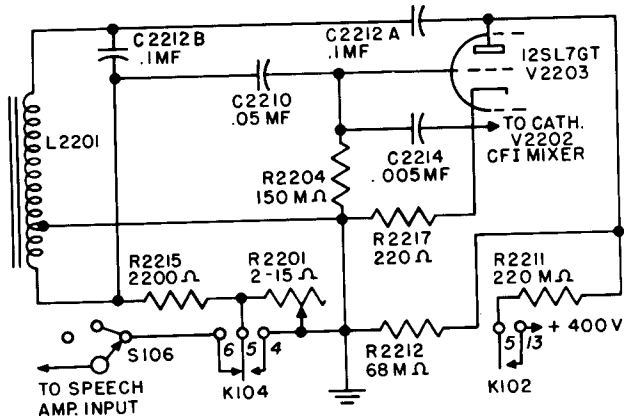

Figure 4-10. MCW Audio Oscillator Circuit

the rear of the MCW-CFI Unit. The voltage developed across resistor R2201 is coupled through contacts 5 and 6 of "voice" relay K104 and power level switch S106 to the speech amplifier input circuit, making the audio oscillator the MCW oscillator when MCW emission is selected. When VOICE emission has been selected, contacts 5 and 6 of voice relay K104 disconnect the output of the audio oscillator section of vacuum tube V2203 from the input circuit of the speech amplifier. During periods of CW transmission the audio oscillator is keyed and the output is fed to the input of the speech amplifier and the sidetone amplifier to provide a means of monitoring the keying.

**Note**

MCW Audio Oscillator high voltage bleeder resistor R2212 is composed of a 100,000 ohm half watt resistor and a 220,000 ohm half watt resistor connected in parallel to give a value of 68,000 ohms one watt.

**6. RADIO-FREQUENCY CIRCUITS.**

The Type T-47/ART-13 Transmitter, as supplied, employs a radio frequency system covering the frequency range 2000 kc to 18,100 kc. When the Type 0-16/ART-13 Low Frequency oscillator unit is installed in the transmitter, the frequency range is extended to include 200 kc to 1500 kc. When the Type 0-17/ART-13A LF Oscillator is installed in the transmitter, the frequency range is extended to include the band 200 kc to 600 kc. Separate oscillator tubes are employed for the high and low frequency ranges. The same power amplifier tube serves both systems. Refer to figure 4-13. and figure 4-17. page 4-15.

*a. LOW - FREQUENCY CIRCUITS.* — The LF oscillator which operates in the frequency range 200 kc to 1500 kc, employs a Type 1625 beam pentode tube, V401. This frequency range is covered in six bands. Refer to the oscillator calibration curves, Section VI, figure 6-1. for the frequency coverage of the individual bands. A combination of capacitive and inductive grid tuning is employed. The LF oscillator COARSE tuning switch, S401, varies the grid circuit capacity by increasing the number of padding capacitors connected in the circuit as the switch is rotated toward the lowest frequency position. Refer to figure 4-12. LF oscillator COARSE tuning switch S401 also changes the tap on the LF oscillator grid inductor L401 to vary the inductance in the grid circuit. Trimmer capacitors have been connected in parallel with the padding capacitors to provide means of fine adjustment of grid circuit capacity. These trimming capacitors are of the ceramic type and the capacity of each may be varied by rotating

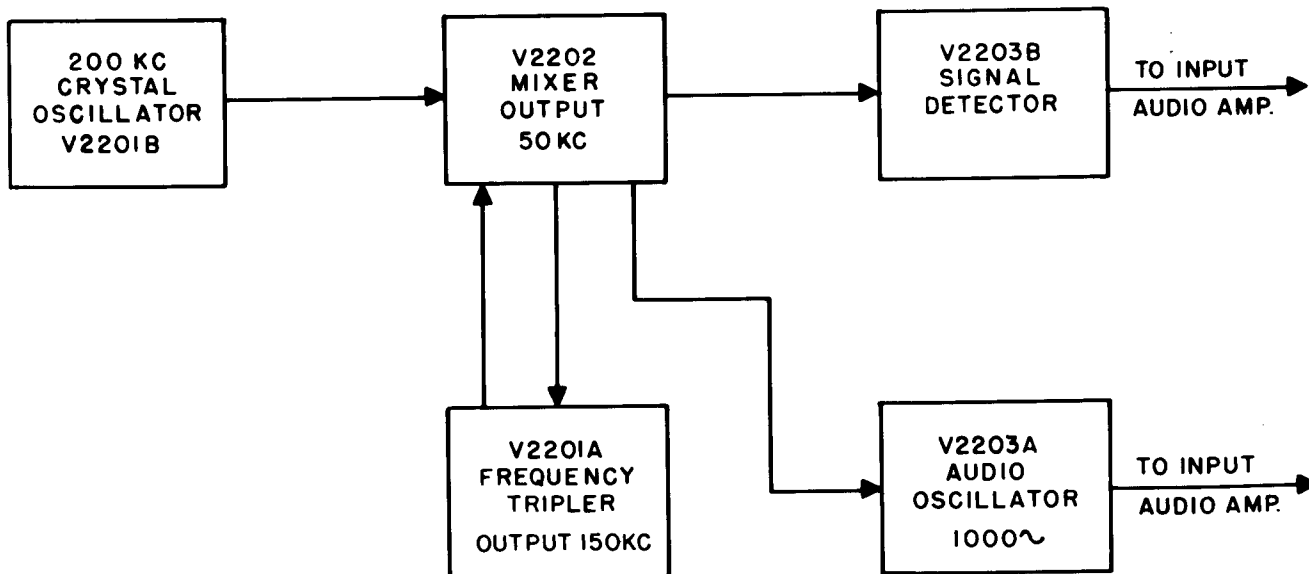

Figure 4-11. MCW-CFI Circuits Block Diagram



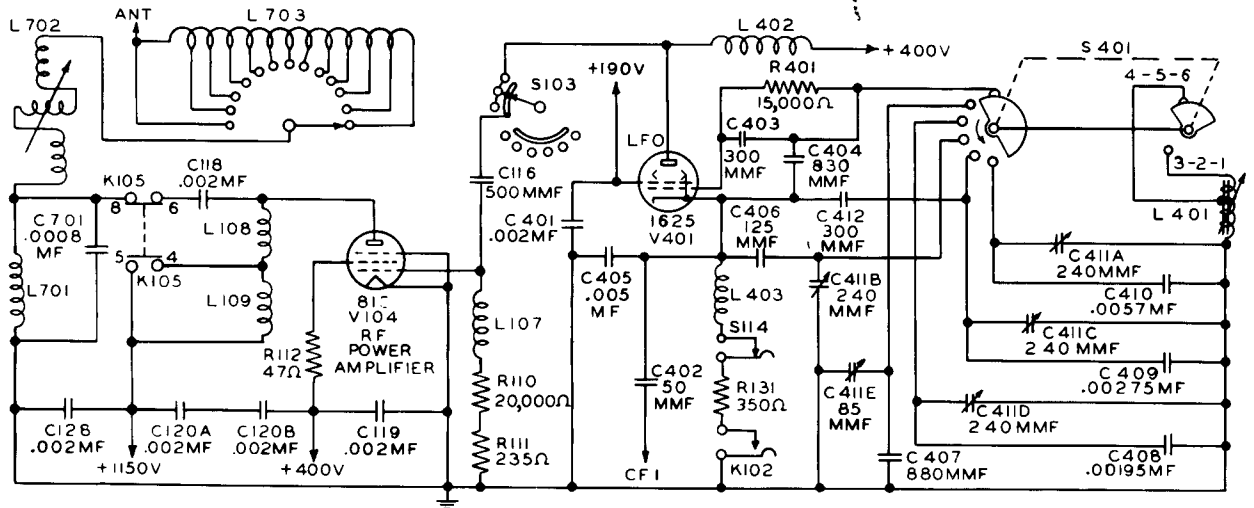

Figure 4-12. Low Frequency RF-Circuits in installations Using LFO O-16/ART-13

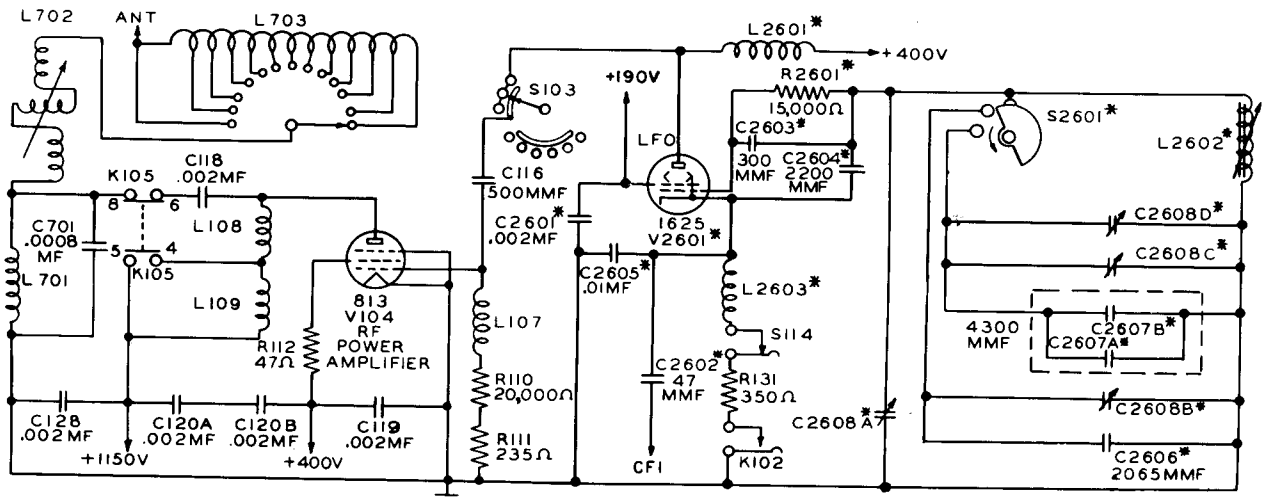

Figure 4-12A. Low Frequency RF Circuits in Installations Using LFO O-17/ART-13A

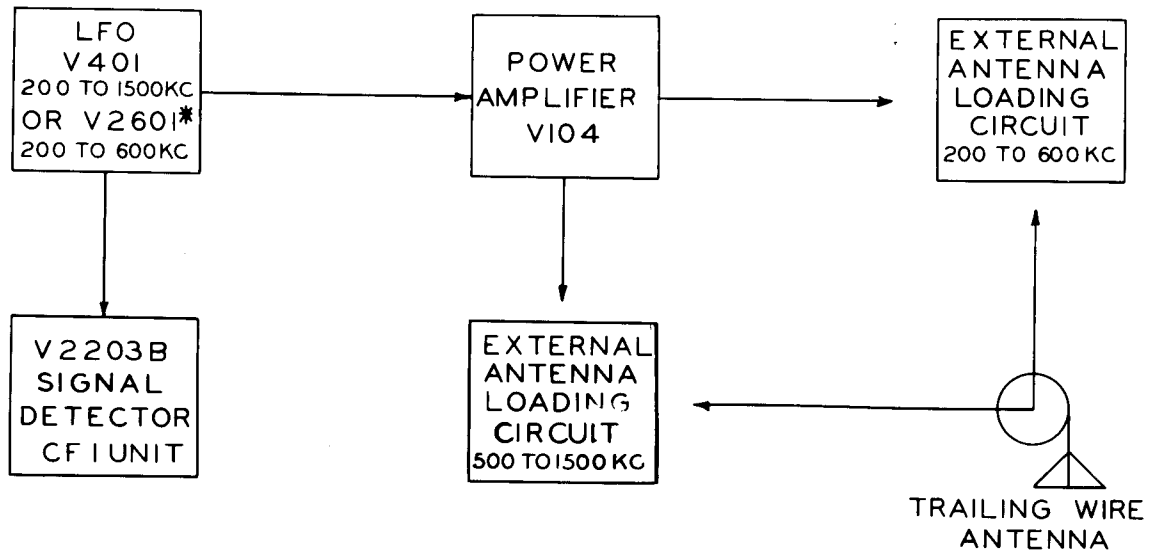

Figure 4-13. Low Frequency RF Circuits Block Diagram

one plate with respect to the other. In spite of the small physical size, this type of capacitor provides a means of varying the capacity over a wide range. With the end-points of the frequency band set and the trimmer capacitors adjusted to give some overlap in each position of LF oscillator COARSE tuning switch S401, all fine frequency adjustments within the frequency range of each switch position is made by varying the inductance of the inductor L401. The inductance of L401 is altered by adjusting the position of the core, which is actuated by a tuning screw. In installations equipped with Type 0-17/ART-13A LF oscillator, the low frequency range is covered in three bands. Refer to the oscillator calibration curves, Section VI, figure 6-1A. The operation of this oscillator is similar to that of Type 0-16/ART-13. V2601\*, S2601\* and L2602\* are the oscillator tube, COARSE tuning switch and grid inductor respectively. No tap is provided on the latter. A portion of the output of the LF oscillator tube, V401 is fed to the grid of the CFI detector tube, V2203, to permit the calibration of LF oscillator tube V401 against the crystal oscillator circuit of the CFI unit. The position of the tuning core within the inductor is determined by Control "G". When LF operation is desired and the LF (13) position of Control "A" has been selected, the cathode circuit of the LF oscillator tube, V401, is coupled through the contacts of oscillator selecting switch S114 and bias resistor R131 to contacts 3 and 9 of keying relay K102. Operation of keying relay K102 completes the cathode circuit to ground. Screen voltage for LF oscillator tube V401 is obtained by tapping the dynamotor low voltage output bleeder. The output of LF oscillator tube V401 is coupled to the grid of the final amplifier tube, V104, by second multiplier range switch S103 when control "A" is operated to the LF position. Selecting LF operation operates output circuit selecting relay K105 which connects the plate circuit of final amplifier tube V104 to the external loading coil. The HF output network is completely removed from the circuit by the operation of output circuit selecting relay K105. Contacts of output circuit selecting relay K105 remove the shorting connection across the plate choke, L109. Screen voltage for final amplifier tube V104 is obtained from the low voltage output of the dynamotor while the full voltage of the dynamotor is applied to the plate of tube V104. The external loading coil in addition to being an antenna loading coil is also the power amplifier plate tank circuit. A tapped inductor and variometer provide means of adjusting the power amplifier plate tank tuning.

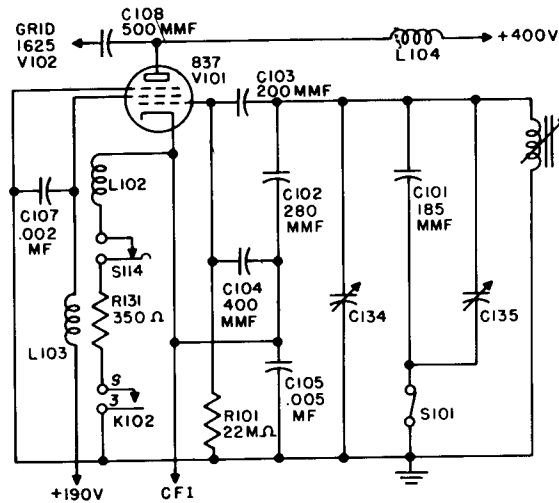

Figure 4-14. High Frequency Oscillator Circuit

b. HIGH-FREQUENCY OSCILLATOR CIRCUITS.—The HF oscillator (figure 4-14.) employs a pentode Type 837 tube, V101, in a variable frequency oscillator circuit operating within the frequency range 1000 kc to 1510 kc. This frequency range is covered in two bands, 1000 kc to 1200 kc and 1200 kc to 1510 kc. The band of frequencies within which output is obtained, is dependent on the position of HF oscillator range switch S101 which is operated by Control "A". Capacitors C101 and C135 are connected in the grid circuit of the HF oscillator tube, V101, by HF oscillator range switch S101. Alternate positions of Control "A" add or remove the padding capacitors C101 and C135. With Control "A" in the 2.0 MC to 2.4 MC position HF oscillator range switch S101 is closed, giving the maximum grid circuit capacitance and consequently the lowest frequency output. Refer to the Oscillator calibration curves, Section VI, figure 6-2. Therefore, when Control "A" is in the 2.0 MC to 2.4 MC position, oscillator output is obtained in the frequency range 1000 kc to 1200 kc. When Control "A" is rotated to the 2.4 MC to 3.0 MC position, HF oscillator range switch S101 is opened, removing capacitors C101 and C135 from the circuit, and oscillator output is obtained in the frequency range 1200 kc to 1510 kc. When Control "A" is operated to the 3.0 MC to 3.6 MC position, HF oscillator range switch S101 is again operated to the closed position and oscillator output is obtained in the frequency range 1000 kc to 1200 kc. In the remaining nine HF positions of Control "A", HF oscillator range switch S101 is alternately opened and closed to give oscillator output as indicated above. Trimming capacitors C134 and C135 have been provided to aid in setting the end-points of the two frequency bands. When setting the HF end of the 1000 kc to 1200 kc band,

the grid capacity is trimmed using variable capacitor C135 and when the HF end of the 1200 kc to 1510 kc band is set, the grid tuning capacity is trimmed by using variable capacitor C134. Fine frequency adjustment within each band is made by varying the inductance of grid tuning inductor L101 which is varied by adjustment of the position of the tuning slug within the coil. The position of this tuning slug is determined by Control "B". Approximately 20 revolutions of Control "B" will cover the entire frequency range of the band upon which the oscillator is operating, with some overlap on the ends of the band. A portion of the output of the HF oscillator tube, V101, is fed to the grid of the CFI detector tube, V2203, to permit the calibration of HF oscillator tube V101 against the crystal oscillator circuit of the CFI Unit. When HF operation has been selected, rotating Control "A" to any one of the twelve HF positions will close the cathode circuit of the HF oscillator tube V101 through cathode choke L102, the contacts of oscillator selecting switch S114 and the cathode resistor R131, to contacts 3 and 9 of keying relay K102. The operation of keying relay K102 completes the cathode circuit to ground. Screen voltage for HF oscillator tube V101 is obtained by tapping the bleeder across the low voltage output of the dynamotor while the full voltage of the low voltage section of the dynamotor is applied to the plate.

c. MULTIPLIER CIRCUITS. (*figure 4-15.*)

(1) To obtain RF output in the frequency range 2000 kc to 18,100 kc, the output of the HF oscillator must be multiplied from two to twelve times. The frequency multiplier stages which employ Type 1625 beam pentode tubes are inoperative when LF operation has been selected. The first multiplier tube, V102, may operate as a frequency doubler, tripler, or quadrupler. The second multiplier tube, V103, operates only as a frequency tripler. The number of times that the frequency of the output of the HF oscillator tube, V101 is multiplied is dependent upon the position of first multiplier range switch S102 and second multiplier range switch S103. The position of the multiplier range switches is determined by Control "A" which has twelve HF positions and one LF position available. The twelve HF positions permit selection of any output frequency within the frequency range 2000 kc to 18,100 kc while the LF position permits the selection of any output frequency within the frequency range 200 kc to 1500 kc.

(2) The 13 positions of Control "A" and the frequency range covered by each are tabulated below:

HIGH FREQUENCY Control Position "A"	TUNING—COARSE Frequency Range
1	2.0 to 2.4 MC
2	2.4 to 3.0 MC
3	3.0 to 3.6 MC
4	3.6 to 4.0 MC
5	4.0 to 4.8 MC
6	4.8 to 6.0 MC
7	6.0 to 7.2 MC
8	7.2 to 9.0 MC
9	9.0 to 10.8 MC
10	10.8 to 12.0 MC
11	12.0 to 14.4 MC
12	14.4 to 18.1 MC
13	200 KC to 1500 KC

(3) In the first six positions of Control "A", only the first frequency multiplier tube, V102, is in operation. First multiplier range switch S102 connects the output circuit of the first frequency multiplier tube, V102, to the input circuit of the final amplifier tube, V104. With Control "A" in Position 1 or 2, tube V102 operates as a frequency doubler. With Control "A" in Position 3 or 4, first multiplier tube V102 operates as a frequency tripler. With Control "A" in Position 5 or 6, first multiplier tube V102 operates as a frequency quadrupler. First multiplier range switch S102 is a twelve-position switch which connects padding capacitors across the first multiplier tube V102 plate tuning inductor, L105. The capacity of the tank circuit is reduced as Control "A" is rotated through positions 1 through 6; thus increasing the frequency of the output of first multiplier tube V102. When Control "A" is in position 7, the second multiplier tube, V103, is in operation. First multiplier range switch S102 connects the output circuit of first multiplier tube V102 to the grid circuit of second multiplier tube V103 and breaks the circuit from the first multiplier tube V102 output circuit to the grid circuit of final amplifier tube V104. The second multiplier tube, V103, operates as a frequency tripler. Control "A" when in Positions 7 to 12 inclusive, also operates second multiplier operating switch S115 connecting the cathode of second multiplier tube V103 through bias resistor R129 to ground. The first multiplier tube, V102 operates as a frequency doubler when Control "A" is in Position 7 or 8, as a frequency tripler when Control "A" is in Position 9 or 10, and as a frequency quadrupler when

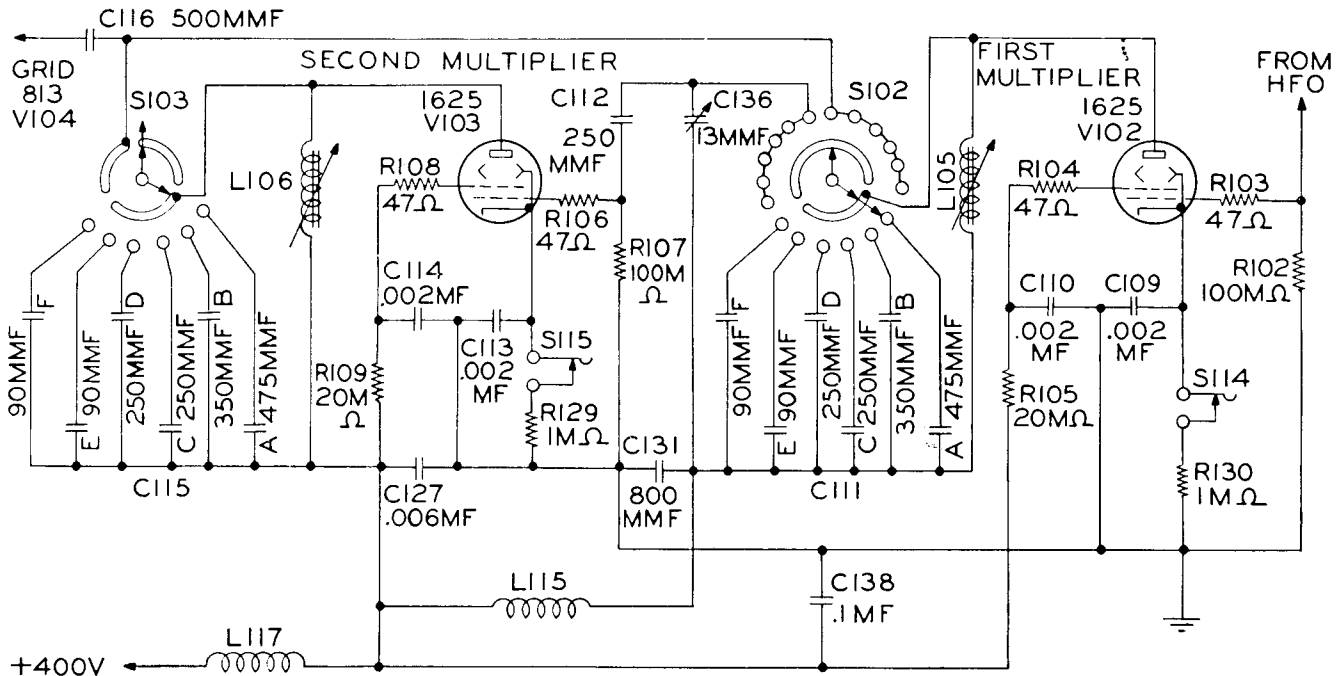

Figure 4-15. High Frequency Multiplier Circuit

Control "A" is in Position 11 or 12. Second multiplier range switch section S103 connects the sections of padding capacitor C115 across the second multiplier tube V103 plate inductor, L106. Capacitors C111 and C115 are of the ceramic type in which the capacity of each section may be adjusted. The frequency multiplier stages are aligned by adjusting the capacity of C111 and

C115 and the inductance of the plate tank inductors L105 and L106. The tuning slugs within inductors L105 and L106 are ganged with the tuning slug of L101, but may be adjusted in respect to each other and with respect to the tuning slug of L101, to obtain proper tracking within each frequency band. Plate and screen voltages for the frequency multiplier tubes, V102 and V103,

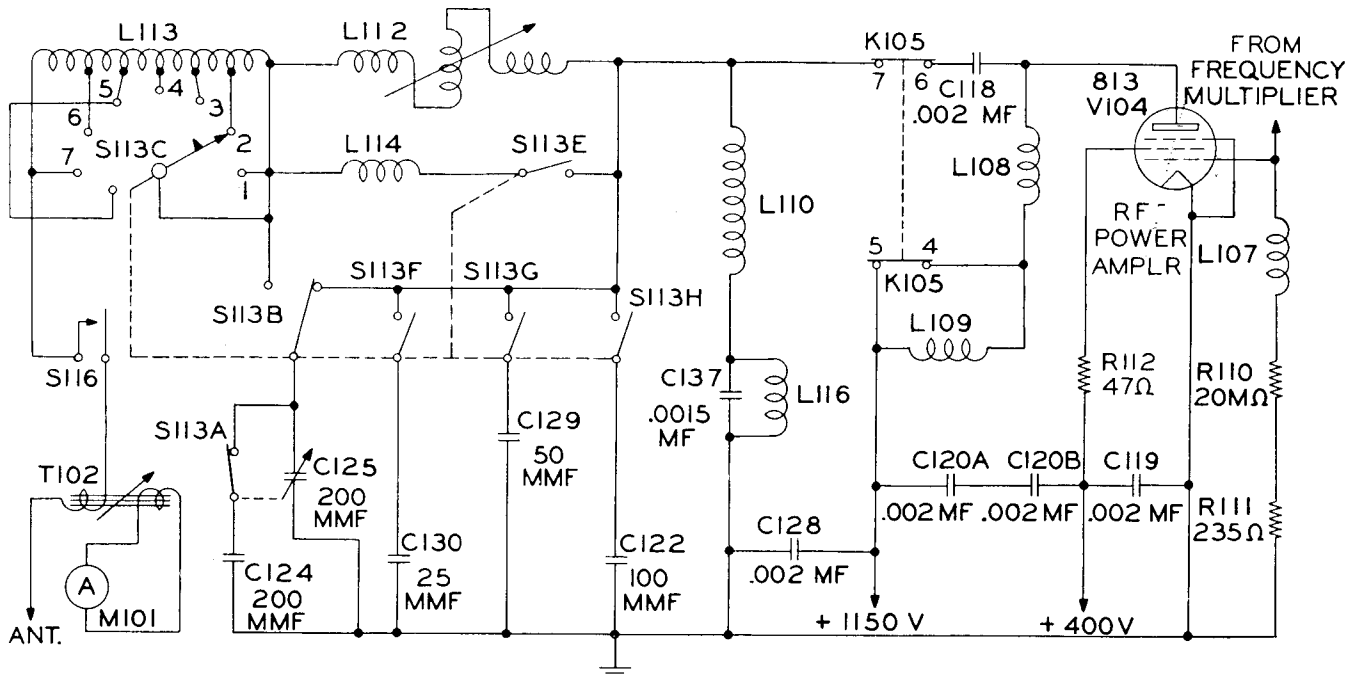

Figure 4-16. High Frequency Power Amplifier Circuit

are furnished by the low voltage section of the dynamotor. The voltage for application to the tube screens is dropped from the 400 volt output of the dynamotor to approximately 270 volts by dropping resistors R105 and R109.

*d. POWER AMPLIFIER AND OUTPUT NETWORK.* (figure 4-16.)

(1) The power amplifier stage employs a Type 813 beam pentode tube operating as a straight amplifier at all frequencies. When operating in the frequency range 200 kc to 1500 kc, the output of the LF oscillator is capacitively coupled to the grid of the power amplifier. When the transmitter operates in the frequency range 2.0 MC to 6.0 MC the output of the first frequency multiplier tube, V102, is coupled to the grid of the power amplifier through first multiplier range switch S102 contacts and capacitor C116. When operating in the frequency range 6.0 MC to 18.1 MC the output of the second frequency multiplier tube, V103, is coupled to the grid of the final amplifier tube, V104, through second multiplier range switch contacts S103 and capacitor C116. When LF operation has been selected output circuit selecting relay K105 connects the plate circuit of the final amplifier tube, V104, to external loading coil terminal J117. With output circuit selecting relay K105 in the normal position the plate circuit of final amplifier tube V104 is connected to the output

network that is incorporated in the transmitter proper. Screen voltage for the power amplifier is supplied by the low voltage section of the dynamotor. Screen voltage is applied to final amplifier tube V104 through relay contacts 5 and 13 when the keying relay K102, is operated. The operation of output circuit selecting relay K105 performs four functions, namely, (1) connection of the output of the power amplifier to external loading coil terminal J117, (2) disconnection of the antenna tuning and power amplifier plate tank circuit, (3) addition of an additional RF choke, L109, in series with the power amplifier feed choke, L108, and (4) connection of the positive 28 volt dc lead to external relay connector J107. When output circuit selecting relay K105 is in the normal position, the output of the power amplifier tube is coupled to the plate tank and antenna coupling network in the transmitter proper through the capacitor C118 while the RF choke, L109, is shorted out. The full output voltage of the high voltage section of the dynamotor is applied to the plate of final amplifier tube V104.

(2) The output network operates as either a pi or L section. The multi-section output network switch, S113, connects the capacitors and inductors in the proper positions to permit matching the power amplifier plate circuit to most aircraft antennas at any frequency within the range 2000 kc to 18,100 kc.

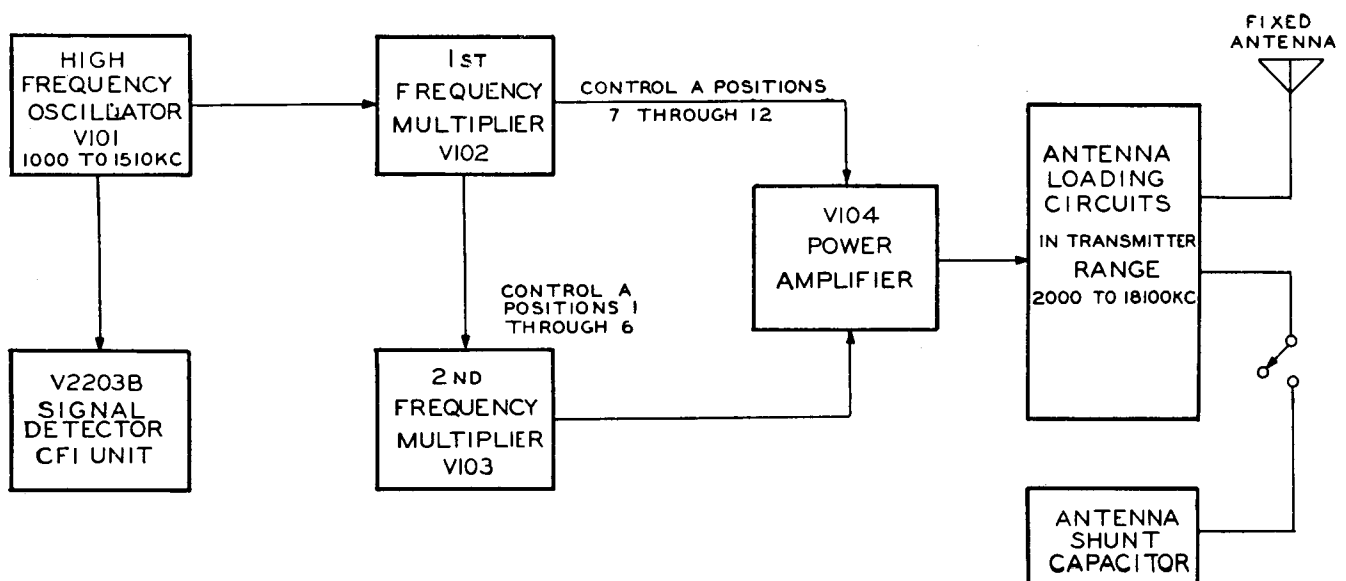

Figure 4-17. High Frequency RF Circuits Block Diagram

(3) The following table will help the operator to better understand the operation of the switch S113:

Control "C" Position	S113A	S113B	S113C	S113E	S113F	S113G	S113H
1	Operated by the Rotation of C125. (Operated When Dial E Reads in 0-100 Range)	1	1	OPEN	OPEN	OPEN	OPEN
2		1	2	OPEN	OPEN	OPEN	OPEN
3		1	3	OPEN	OPEN	OPEN	OPEN
4		1	4	OPEN	OPEN	OPEN	OPEN
5		1	5	OPEN	OPEN	OPEN	OPEN
6		1	6	OPEN	OPEN	OPEN	OPEN
7		1	7	OPEN	OPEN	OPEN	OPEN
8		2	7	OPEN	CLOSED	CLOSED	CLOSED
9		2	7	OPEN	OPEN	OPEN	CLOSED
10		2	7	OPEN	OPEN	CLOSED	OPEN
11		2	7	OPEN	CLOSED	OPEN	OPEN
12		2	7	OPEN	OPEN	OPEN	OPEN
13		2	7	CLOSED	OPEN	CLOSED	OPEN

(4) The variometer, L112, is operated by Control "D". The variable capacitor C125 is operated by Control "E". The above network Controls "C", "D" and "E" are connected to the Autotune system, but may be manually operated without disturbing the positions of the Autotune stop rings when the CHANNEL selector switch, S108, is placed in the MANUAL position and the Autotune system allowed to operate. The network will tune and deliver rated power to antennas 17 feet to 60 feet in length throughout the frequency range 3000 kc to 18,100 kc. If operation in the range 2000 kc to 3000 kc is desired, it may be necessary to connect the Type CU-24/ART-13 Antenna Shunt Capacitor (*figure 6-42. page 6-51*) across the network output.

## 7. AUTOTUNE SYSTEM.

### a. GENERAL.

(1) The Autotune System is an electrically controlled means of mechanically repositioning adjustable elements such as tap switches, variable inductors, variable capacitors, etc. Any combination of these items can be tuned to any one of eleven preselected frequencies in a period of twenty-five seconds at normal room temperature and with a normal supply voltage, by the use of the Autotune system. Provision has also been made to permit manual tuning of the radio equipment.

(2) The Autotune assembly consists of a group of positioning mechanisms, one being applied to each tuning element to perform the same function as a manual tuning knob. Each positioning mechanism provides precise angular setting of the tuning control to any one of eleven angular

positions, each of which is readily adjustable. The settings for each frequency and for each control are entirely independent.

(3) The positioning accuracy of the Autotune mechanism is of a very high order. Each setting is inherently independent of wear, backlash, alignment, supply voltage, etc. The accuracy of the settings is comparable to that of vernier manual controls. The parts are machined within close limits, and although operation is very precise, there are no delicate adjustments or fragile mechanisms. Permanently lubricated bearings are used in many places and the assembly is enclosed and protected from dust and corrosion.

### b. MECHANICAL DETAILS.

#### Note

The numbers that appear in the following section before the names of the various parts of the Autotune mechanism correspond to the symbols that are used to identify the parts on figure 4-18.

(1) LINE SHAFT.—The line shaft extends the entire length of the Autotune casting and drives all the Autotune units. Power is applied to the shaft from the motor (47) by means of a chain drive (48).

(2) SINGLETURN WORM.—The singleturn unit is driven by one worm on the line shaft (1).

(3) CAM DRUM DRIVE SPUR GEAR.—This gear is fastened directly to the slip clutch worm gear (4) and drives the cam drum spur gear (10) through the idler gear (14).

(4) SLIP CLUTCH WORM GEAR.—This gear is fastened to the cam drum drive spur gear (3) and drives the stop-ring drum (12) through

AN 08-30ART13-5

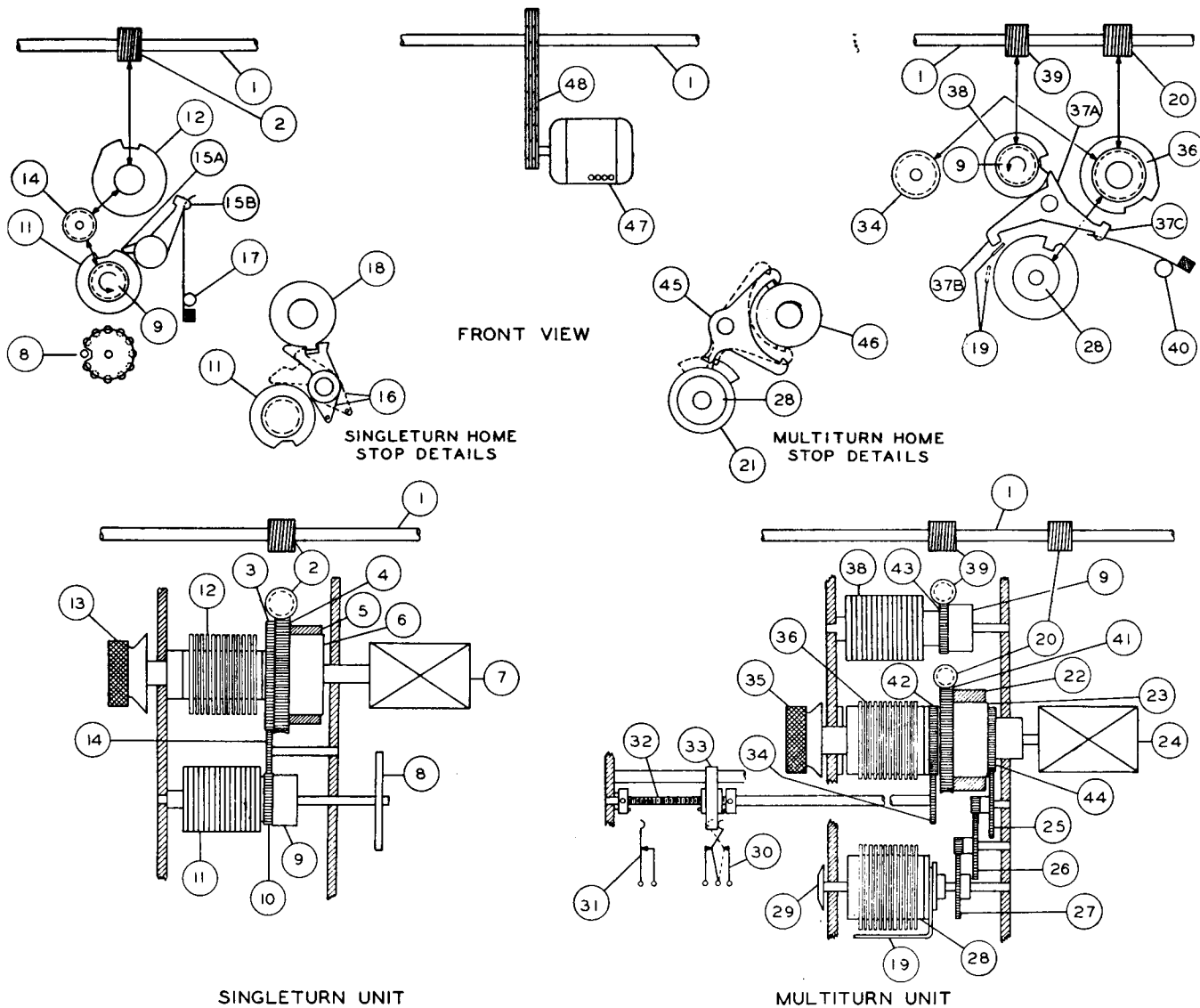

KEY TO SYMBOLS

- |                                       |                                 |   |
|---------------------------------------|---------------------------------|---|
| 1-LINE SHAFT                          | 17-PAWL SPRING                  | 33-SWITCH OPERATING ARM                                   |
| 2-SINGLETURN WORM                     | 18-SINGLETURN HOME STOP RING    | 34-LIMIT SWITCH DRIVE SHAFT SPUR GEAR                     |
| 3-CAM DRUM DRIVE SPUR GEAR            | 19-ANVIL                        | 35-MULTITURN DIAL   |
| 4-SLIP CLUTCH WORM GEAR               | 20-MULTITURN WORM #1            | 36-STOP RING DRUM   |
| 5-SLIP CLUTCH BAND                    | 21-MULTITURN HOME STOP CAM      | 37-PAWL (37A-PAWL HEEL)<br>(37B-PAWL TAIL) (37C-PAWL TOE) |
| 6-SLIP CLUTCH DRUM                    | 22-SLIP CLUTCH BAND             | 38-CAM DRUM   |
| 7-TUNED ELEMENT                       | 23-SLIP CLUTCH DRUM             | 39-MULTITURN WORM #2                                      |
| 8-CIRCUIT SEEKING TAP SWITCH          | 24-TUNED ELEMENT                | 40-PAWL SPRING  |
| 9-SINGLE TOOTH RATCHET                | 25-IDLER GEAR #1                | 41-STOP RING DRUM WORM GEAR                               |
| 10-CAM DRUM SPUR GEAR                 | 26-IDLER GEAR #2                | 42-STOP RING DRUM SPUR GEAR                               |
| 11-CAM DRUM                           | 27-COUNTER DRUM SPUR GEAR       | 43-CAM DRUM WORM GEAR                                     |
| 12-STOP RING DRUM                     | 28-COUNTER DRUM                 | 44-COUNTER DRUM DRIVE GEAR                                |
| 13-SINGLETURN DIAL                    | 29-TURN COUNTER DIAL            | 45-MULTITURN HOME STOP PAWL                               |
| 14-IDLER GEAR                         | 30-REAR LIMIT SWITCH SECTION    | 46-MULTITURN HOME STOP RING                               |
| 15-PAWL (15A-PAWL HEEL)(15B-PAWL TOE) | 31-FORWARD LIMIT SWITCH SECTION | 47-AUTOTUNE MOTOR   |
| 16-SINGLETURN HOME STOP PAWL          | 32-LIMIT SWITCH DRIVE SHAFT     | 48-CHAIN DRIVE  |

Figure 4-18. Autotune System—Mechanical Details

the slip clutch (6). This gear is driven by the singleturn worm (2).

(5) SLIP CLUTCH BAND.—This band is driven directly from the slip clutch worm gear (4) and presses against the slip clutch drum (6).

(6) SLIP CLUTCH DRUM.—The slip clutch drum, driven by the slip clutch band (5), is fastened to the stop-ring drum shaft.

(7) TUNED ELEMENT.—The tuned element, such as a tap switch, a variable capacitor, or a variometer, is driven directly from the stop-ring drum shaft.

(8) CIRCUIT SEEKING TAP SWITCH.—This switch is driven by the cam drum shaft and is phased so that the contacts are in synchronization with the cams of the cam drums (11) and (38).

(9) SINGLE TOOTH RATCHET. — The single tooth ratchet, when engaged, drives the cam drum. These ratchets keep the cam drums of the various units synchronized.

(10) CAM DRUM SPUR GEAR.—The cam drum spur gear is driven from the line shaft through gears (2), (3) and (14). The spur gear drives the cam drum (11) through the single tooth ratchet (9).

(11) CAM DRUM.—The cam drum consists of twelve cams mounted on a shaft with adjacent cam slots staggered 30 degrees. These cams are rigidly fastened to the drum. The single tooth ratchet (9) mounts on the shaft behind the drum and drives the drum.

(12) STOP-RING DRUM. — The stop-ring drum assembly consists of twelve stop rings mounted on a shaft with spacers between the rings. The stop rings are free to rotate but the spacers are keyed to the shaft such that as one stop ring is rotated, movement of the ring will not affect the adjacent rings which may have been previously adjusted. A locking bar, on the dial locks the stop rings when adjustment has been completed. The locking mechanism consists of a bar that drives a screw to apply pressure to the stack of stop rings and spacers, thereby, in effect, locking them.

(13) SINGLETURN DIAL.—The singleturn dial is fastened to the stop-ring drum (12) and enables the operator to adjust the tuned element (7). The locking bar is located on the front of the dial.

(14) IDLER GEAR.—The idler gear trans-

mits power from the cam drum drive spur gear (3) to the cam drum spur gear (10).

(15A) PAWL HEEL.—The pawl heel is held against the cam drum (11) by the pawl spring (17).

(15B) PAWL TOE.—The pawl toe serves to position the tuned element (7) by dropping into the stop ring slot and stopping the stop-ring drum (12) after the motor (47) reverses and the pawl heel (15A) is in a cam drum slot.

(16) SINGLETURN HOME STOP PAWL.—This pawl limits the rotation of the singleturn unit to one revolution. The pawl is located on the same shaft as the pawl (15) and is engaged by the singleturn home stop ring (18). Referring to the mechanical portion of the Autotune, the pawl as shown in solid lines limits the rotation of the stop-ring drum (12) in the counterclockwise direction. The pawl cannot pivot further because it bears against the stop-ring drum (12) at point "B". The pawl as shown in dotted lines limits the rotation of the cam drum (12) in a clockwise direction. The pawl cannot pivot further in this position because it bears on the cam drum (11) at point "A".

(17) PAWL SPRING. — The pawl spring presses the pawl heel (15A) against the cam drum (11) and when the pawl heel (15A) drops into the cam drum slot, the pawl spring presses the pawl toe (15B) against the stop-ring drum (12).

(18) SINGLETURN HOME STOP RING.—This ring, mounted with the other stop rings on the stop-ring drum (12), is rigidly fastened to the drum. The home stop pawl (16) engages with this ring to limit the rotation of the stop-ring drum (12) to one revolution.

(19) ANVIL.—The anvil prevents the multi-turn pawl tails (37B) from becoming engaged in the counter drum (28) ring slots until after the motor (47) reverses. The solid line position is assumed while the cam drum is turning during the first part of the Autotune cycle; the dotted position after the motor reverses and the cam drum ceases to turn.

(20) MULTITURN WORM 1.—This worm drives the stop-ring drum worm gear (41).

(21) MULTITURN HOME STOP CAM.—This cam is mounted with the other cams on the counter drum (28). This cam actuates the home stop pawl (45) to limit the rotation of the stop-ring drum (36) to twenty-revolutions.

(22) SLIP CLUTCH BAND. — This band,



driven by the worm gear (41), drives the stop-ring drum (36) through the slip clutch drum (23).

(23) SLIP CLUTCH DRUM.—This clutch, similar to (6), is driven by the slip clutch band (22) and is fastened to the stop-ring drum shaft.

(24) TUNED ELEMENT.—This frequency determining element is coupled directly to the stop-ring drum (36).

(25) IDLER GEAR 1.—This gear and gear (26) link the counter drum (28) to the slip clutch spur gear (44) which is fastened to the stop-ring drum (36).

(26) IDLER GEAR 2.—This gear and idler gear #1 (25) link the counter drum (28) to the slip clutch spur gear (44).

(27) COUNTER DRUM SPUR GEAR.—This gear drives the counter drum (28).

(28) COUNTER DRUM.—This drum consists of eleven cams with spacers between them. Like the stop-ring drums (12) and (36), the spacers are keyed to the shaft so that movement of one cam will not disturb adjacent cams. A spring on the rear of the counter drum loads the stack of cams axially so that the rings will not turn too easily.

(29) TURN COUNTER DIAL.—This dial, numbered from 0 to 20, indicates the number of turns the Multiturn unit has made.

(30) REAR LIMIT SWITCH SECTION.—This switch, actuated by the operating arm (33), is normally held in the operated position. During the first part of the Autotune cycle, this switch opens, disabling the keying and dynamotor input relays. As the Autotune cycle nears completion, the operating arm (33) recloses the switch, turning off the motor (47) by restoring the motor torque retainer resistor to the circuit and restoring the coil circuits of the keying and dynamotor input relays.

(31) FRONT LIMIT SWITCH SECTION.—This switch, normally closed, provides a holding circuit for the motor control relay. When the limit switch operating arm (33) opens the switch, the circuit seeking tap switch breaks the operating circuit of motor control relay K101, the unoperated position of which reverses the motor, thereby returning the limit switch operating arm to the original position, completing the cycle.

(32) LIMIT SWITCH DRIVE SHAFT.—This shaft is driven by the gear (34) from the line shaft (1). The screw thread on the shaft moves the switch operating arm forward or backward

between the limit switch sections (30) and (31). On either end of the screw are cams which limit the travel of the switch operating arm (33).

(33) SWITCH OPERATING ARM. — This arm is driven by the threaded drive shaft (32) and controls limit switches (30) and (31).

(34) LIMIT SWITCH DRIVE SHAFT SPUR GEAR.—This gear, driven by the stop-ring drum spur gear (42) drives the limit switch drive shaft (32).

(35) MULTITURN DIAL.—This dial with locking bar enables the operator to adjust the stop-ring drum (36) to any desired operating frequency within the range of the equipment.

(36) STOP-RING DRUM.—See (12).

(37A) PAWL HEEL.—The pawl heel is held against the cam drum (38) by the pawl spring (40).

(37B) PAWL TAIL.—The pawl tail, when allowed to engage the counter drum (28) ring slot by the movement of the anvil (19) selects the revolution in which the tuned element (24) will be positioned.

(37C) PAWL TOE.—The pawl toe serves to position the tuned element (24) by dropping into the stop-ring slot and stopping the stop-ring drum (36).

(38) CAM DRUM.—See (11).

(39) MULTITURN WORM 2. — This worm drives the cam drum (38) through the single tooth ratchet (9).

(40) PAWL SPRING.—This spring is similar to (17).

(41) STOP-RING DRUM WORM GEAR.—This gear, powered from the line shaft (1) by the worm (20), drives the stop-ring drum (36) through the slip clutch (23).

(42) STOP-RING DRUM SPUR GEAR.—This gear is fastened to the stop-ring drum worm gear (41) and drives the limit switch drive shaft (32) through the gear (34).

(43) CAM DRUM WORM GEAR. — This gear, powered from the line shaft (1) by the worm (39), drives the cam drum (38) through the single tooth ratchet (9).

(44) COUNTER DRUM DRIVE GEAR.—This gear, fastened to the slip clutch drum (23) drives the counter drum (28) through the idler gears (25) and (26) and gear (27).

(45) MULTITURN HOME STOP PAWL.—This pawl, actuated to either position shown by

the home stop cam (21), engages the projection on the home stop ring (46) to limit the rotation of the stop-ring drum (36) to 20 revolutions. This pawl is mounted on the same shaft as the pawl (37).

(46) MULTITURN HOME STOP RING.—This ring is engaged by the pawl (45) and is mounted on the stop-ring drum (36). The dotted outlines of the home stop ring (46) and pawl (45) show the stop-ring drum (36) in the limit of rotation in the counterclockwise direction. The other position shows limit in the clockwise direction.

(47) AUTOTUNE MOTOR.—The Autotune motor is a dc shunt wound reversible type and applies power to the line shaft (1) through the chain drive (48).

(48) CHAIN DRIVE. — The chain drive transmits the power from the Autotune motor (47) to the line shaft (1) and consists of a driving pinion coupled to a driven sprocket by a chain.

c. ELECTRICAL DETAILS.

(Refer to figure 4-19.)

(1) B101 AUTOTUNE MOTOR.—The Autotune motor operates from the 28 volt direct current power source and is controlled by the limit switches, S111 and S112, and motor control relay, K101.

(2) K101 MOTOR CONTROL RELAY.—K101 is energized through the contacts of the keying relay, K102, the LOCAL-REMOTE switch, S107, the channel selector switch, S108, and the circuit seeking tap switch, S109, to ground. The holding circuit for the relay is through contacts 5 and 6 of motor control relay K101 and the contacts of front limit switch section, S112. When operated, motor control relay K101 disables keying relay K102 and dynamotor input relay K2101 preparatory to the release of rear limit switch section S111.

(3) K102 KEYING RELAY.—K102, when operated during periods of transmission, prevents false operation of the Autotune system. The energizing circuit is through the emission control circuits, that is the TEST switch, S104, the Throttle Switch jack, J101, the MICROPHONE jack, J102, or the KEY jack, J103.

(4) S107 LOCAL-REMOTE SWITCH.—S107 permits the selection of either the panel channel selecting circuit or the remote channel selecting

circuit. This switch is located on the transmitter panel and is designed for manual operation only.

(5) S108 CHANNEL SELECTING SWITCH.—S108 permits the selection of any one of eleven AUTOTUNE frequency channels and "MANUAL" tuning of the transmitter. The selection of a new channel energizes motor control relay K101 by the current through CHANNEL selecting switch S108 and circuit seeking switch S109 to ground.

(6) S109 CIRCUIT SEEKING TAP SWITCH.—S109 is driven by the Autotune motor, B101, through a worm and spur gear arrangement. The circuit seeking tap switch, S109, completes the circuit necessary for the operation of the motor control relay, K101. Of the twelve circuits connected to the circuit seeking tap switch, S109, eleven are grounded at all times. The operation of motor control relay K101 connects front limit switch section S112 in the circuit, preventing seeking switch S109 from finding the circuit selected by CHANNEL selecting switch S108 until after the limit switch operating arm reaches and operates front limit switch section S112.

(7) S111 REAR LIMIT SWITCH SECTION.—S111 is normally held in the position necessary to complete the circuit for the operation of keying relay, K102, and dynamotor input relay K2101. When released by the limit switch operating arm, contacts 2 and 3 of the rear limit switch section, S111, short motor torque retainer resistor R115 out of the circuit preparatory to the release of motor control relay K101. The return of the limit switch operating arm to the original position opens contacts 2 and 3 of rear limit switch section S111, placing motor torque retainer resistor R115 again in the circuit, thereby stopping Autotune motor B101.

(8) S112 FRONT LIMIT SWITCH SECTION.—The normally closed contacts of S112 complete the holding circuit for motor control relay K101 through contacts 5 and 6 of K101. When the front limit switch section, S112, is operated by the switch operating arm, allowing circuit seeking tap switch S109 to find the circuit position selected by CHANNEL selecting switch S109, the operating circuit for motor control relay K101 is broken allowing K101 to release. De-energizing of motor control relay K101 reverses the direction of rotation of the Autotune motor, B101.

(9) S113D KEYING INTERLOCK SWITCH.—S113D is operated by the "ANTENNA TUNING—COARSE", Control "C", and prevents the

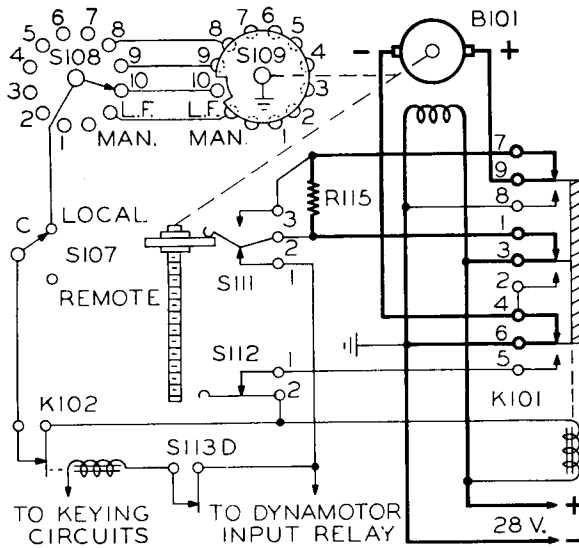

1. Electrical portion of the Autotune system at the close of a previous cycle of operation for channel 10. Transmitter turned on.

- |  |                                       |
|--|---------------------------------------|
| B101—AUTOTUNE MOTOR                      | S108 —CHANNEL SE-<br>LECTOR SWITCH    |
| K101—MOTOR CONTROL<br>RELAY              | S109 —CIRCUIT SEEKING<br>TAP SWITCH   |
| K102—KEYING RELAY                        | S111 —REAR LIMIT<br>SWITCH SECTION    |
| R115—MOTOR TORQUE RE-<br>TAINER RESISTOR | S112 —FORWARD LIMIT<br>SWITCH SECTION |
| S107—LOCAL-REMOTE<br>SWITCH              | S113D—KEYING INTER-<br>LOCK SWITCH    |

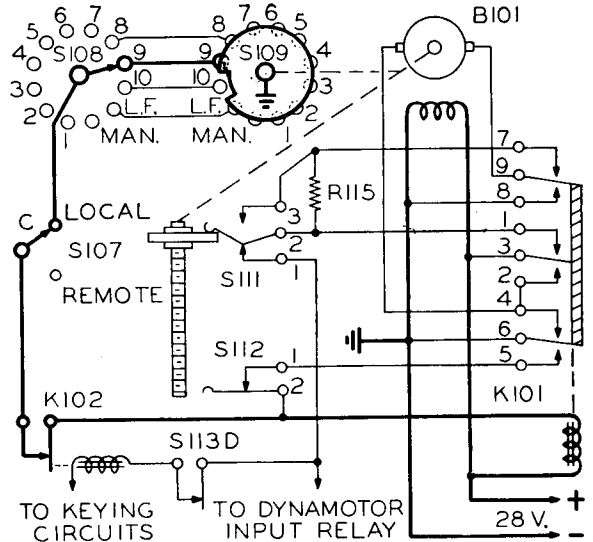

2. Operator turns CHANNEL selector switch S108 to channel 9. Coil of motor control relay K101 is energized by circuit through keying relay K102, LOCAL-REMOTE switch S107, CHANNEL selector switch S108 and circuit seeking tap switch S109. Motor torque retainer resistor R115 is disconnected. Dynamotor input relay and keying relay K102 are disabled preparatory to the release of rear limit switch section S111.

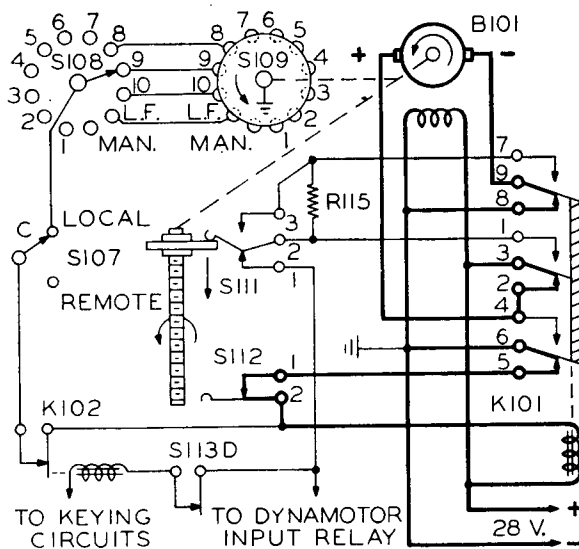

3. Motor control relay has operated. Motor B101 starts, causing circuit seeking tap switch S109 and limit switch operating arm lead screw to rotate. Relay remains operated by circuit through relay contacts 5 & 6 and contacts of forward limit switch section S112.

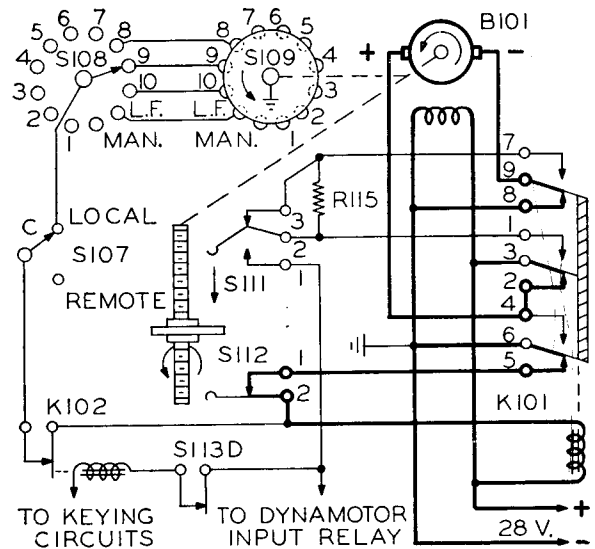

4. Autotune system in full operation. The limit switch operating arm has moved away from and thereby allowed forward limit switch section S111 to return to the unoperated position. The return of this switch removes the short from motor torque retainer resistor R115 and breaks the circuit to the dynamotor input relay and keying relay K102 preparatory to the release of motor control relay K101.

Figure 4-19. Electrical Autotune Operation Sequence  
(Sheet 1 of 2 Sheets)

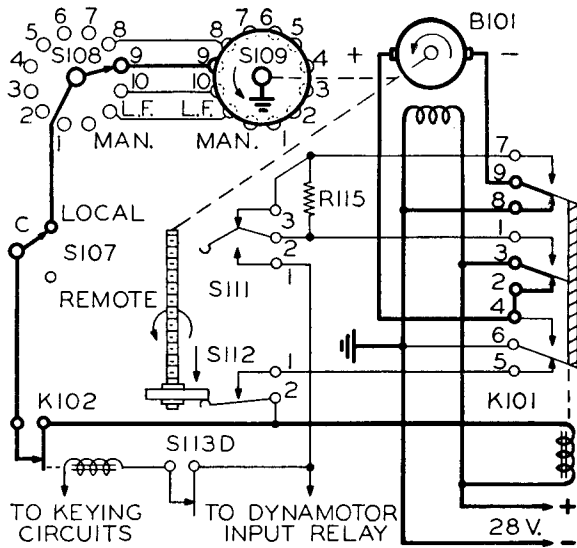

5. All Autotune units have reached the counterclockwise limit. The limit switch operating arm operates forward limit switch section S112. Motor control relay K101 is being energized only by the circuit through circuit seeking tap switch S109.

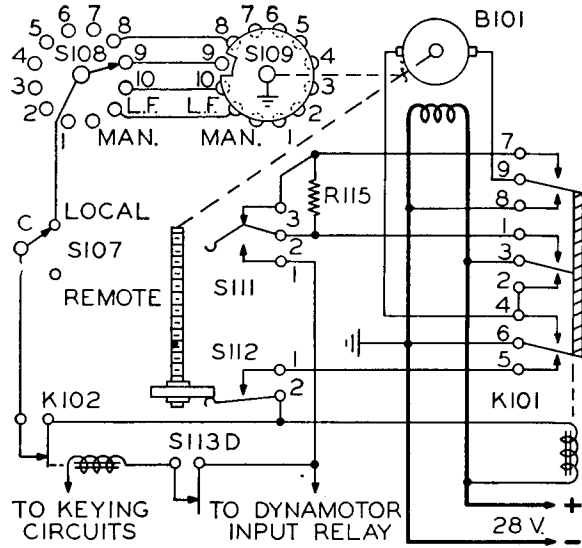

6. The open segment of circuit seeking tap switch has reached contact 9 breaking the circuit that energized the coil of motor control relay K101. Motor control relay K101 is beginning to release and has broken the circuit to the armature of motor B101. Motor B101 and all driven Autotune elements stop. At this point all positioning pawls for channel 9 have just fallen.

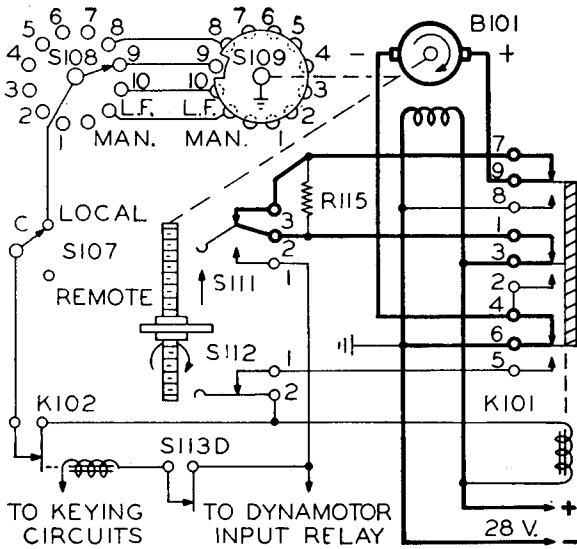

7. Motor control relay K101 has returned to the unoperated position. Polarity of supply voltage to armature of motor B101 is reversed causing motor to operate in opposite direction. Due to ratchets, circuit seeking tap switch S109 and the cam drums are allowed to remain stationary for remainder of Autotune cycle. Reversal of the lead screw has caused the limit switch operating arm to move away from and thereby allow forward limit switch section S112 to reclose. Channel 9 pawls are engaging respective stop rings thereby positioning tuned elements.

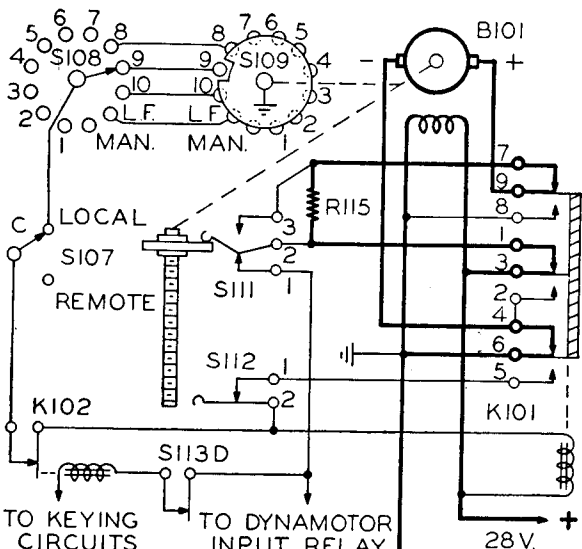

8. All tuned elements are positioned on channel 9. Limit switch operating arm has reached and operated rear limit switch S111. Operation of rear limit switch S111 stops motor B101 by removing short from motor torque retainer resistor R115 and restores circuit for operation of dynamotor input relay and keying relay K102. Motor torque retainer resistor R115 allows just enough current to flow in armature of motor B101 to provide a position retaining torque to the Autotune units.

Figure 4-19. Electrical Autotune Operation Sequence  
(Sheet 2 of 2 Sheets)

operation of the keying relay, K102, between settings of Control "C".

d. AUTOTUNE OPERATION.—The Autotune system consists of one Multiturn unit and four Singleturn units (refer to figure 4-18., figures 5-12., 5-13. page 5-36 and figures 5-14., 5-15. page 5-37) which are driven by a reversible motor through a line shaft. The Multiturn unit may be set up to select any dial setting in a continuous range of 7200 angular degrees (twenty turns or revolutions) of dial rotation.

#### Note

One revolution of the dial is equal to 360 angular degrees of rotation. The Singleturn units may be set up to select any dial setting from 0 to 360 degrees of rotation (a single turn or revolution). The drawings of the electrical and mechanical portions of the Autotune, figure 4-19. and figure 4-18., should be referred to in connection with the description of the following operational sequence. The drawings show the Autotune at the completion of the operation cycle.

(1) The operator turns the CHANNEL selector switch, S108, to the channel desired.

(2) This places a ground on the motor control relay K101 through the circuit seeking tap switch, S109, the CHANNEL selector switch, S108, the LOCAL-REMOTE switch, S107, and the contacts of the keying relay, K102. With the keying relay, K102, in the normal or unenergized position, the motor control relay, K101, will operate and energize the Autotune motor, B101. The motor control relay, K101, is then kept energized by the circuit through contacts 5 and 6 and the limit switch section, S112. The operation of motor control relay K101 disables the keying relay K102.

(3) The motor, B101, drives the line shaft (1) in a forward direction causing all the cam drums and stop-ring drums to rotate in a counterclockwise direction and the multiturn unit counter drum to rotate in a clockwise direction.

(4) The switch operating arm (33) moves out from the rear limit switch section, S111, and moves toward the forward limit switch section, S112. Contacts 1 and 2 of the rear limit switch section, S111, open, keeping keying relay K102 and dynamotor input relay K2101 disabled when the motor control relay, K101, opens. Contacts 2 and 3 of the rear limit switch section short motor

torque resistor R115 out of the circuit preparatory to the release of motor control relay K101.

(5) The forward limit switch section, S112, opens and the motor continues to run until the open segment of the circuit seeking tap switch, S109, is positioned opposite the contact upon which the channel selector switch has been set by the operator.

(6) As the open segment of the circuit seeking tap switch, S109, comes to the contact of the channel selected, the synchronized cam drums are at the position where the pawl heels (15A and 37A) of the channel selected have just dropped into their respective slots in the cam drums.

(7) Since the holding circuit has been removed, the motor control relay, K101, opens, causing the polarity of the voltage on the armature to be reversed, which reverses the direction of rotation of the motor.

(8) After the motor reverses, allowing the cam drums to fully engage their respective pawl heels, the switch operating arm moves toward the rear, allowing the forward limit switch section, S112, to reclose.

(9) As the motor continues to run in the reverse direction, the stop-ring drum (12) of the singleturn unit rotates and when the slot on the stop ring of the channel selected is adjacent to pawl toe (15B) the pawl toe drops into the slot. The pawl toe stops the tuned element (7) at the predetermined position and the clutch slips until the Autotune cycle has been completed.

(10) The counter drum (28) of the multiturn unit reverses direction of rotation thereby rotating the anvil (19) out from under the pawl tail (37B) as the motor reverses, and when the slot of the cam on the counter drum, of the channel selected, is adjacent to the pawl tail (37B), the pawl tail drops into the slot and selects the revolution in which the tuned element (24) will be positioned.

(11) As soon as the slot in the proper stop ring of the stop-ring drum (36) is adjacent to the pawl toe (37C) the pawl toe drops into the slot. This stops the tuned element (24) at the preselected position and the clutch (23) slips until the Autotune cycle has been completed.

(12) As the motor continues in the reverse direction, the switch operating arm moves back against the rear limit switch section, S111, opening contacts 2 and 3 of S111.

(13) Contacts 2 and 3 of the rear limit switch section upon opening remove the short across the

motor torque retainer resistor, R115, which stops the motor but allows just enough current to flow through the armature of motor B101 to provide a position retaining torque to the Autotune units.

(14) The contacts 1 and 2 of the rear limit switch section, S111, close, permitting the carrier to be turned on. The Autotune cycle is now complete. The carrier control circuits and Autotune control circuits are interlocked so that the Autotune can not operate when the carrier is on and the carrier cannot be turned on while the Autotune system is in operation.

e. UNIT FUNCTION.

(1) The order of the Autotune units from left to right is as follows: E, C, D, A and B.

(2) Proceeding in the order of unit function; the choice of oscillator, the high frequency oscillator range, the multiplier range and the Autotune seeking switch, S109 are controlled by Autotune unit "A"; the high frequency oscillator tuning is controlled by Autotune unit "B"; the coarse selection of inductance and capacity in connection with a given antenna by Autotune unit "C"; the variometer, providing a fine control of inductance, serving as tuning resonator by Autotune unit "D"; and the large variable capacitor, providing a fine control of capacitance, serving as a loading control, by Autotune unit "E".

(3) The high frequency oscillator, which is the unit at the extreme right of the transmitter is controlled by Autotune unit "B". The multiplier coil forms are mounted at the back of the casting. The slugs of the multiplier coils are attached to the same shaft that controls the oscillator slug. Also mounted in the high frequency oscillator casting is the switch, actuated by a star cam in the adjacent multiplier chassis, which changes the frequency range of the high frequency oscillator.

(4) The multiplier chassis, the operation of which is controlled by Autotune unit "A", contains the star cam mentioned above in addition to a cam operated multi-contact switch which controls the high and the low frequency oscillators. The wafer switch nearest the Autotune unit controls the range of the first multiplier stage, the wafer switch farthest from the Autotune unit controls the range of the second multiplier stage and the remaining cam operates a switch that closes the cathode circuit of the second multiplier stage at the proper time.

(5) Autotune unit "D" controls the variometer.

(6) The network switch, controlled by Autotune unit "C", varies the tap on the loading inductance and the capacity in the circuit. In the first position all of the inductance is in the circuit and in the seventh position this inductance is completely shorted out. Between ranges seven and eight switch S113 operates to cut in the ceramic padding capacitors, various combinations of which are used from ranges eight to thirteen. In addition, a small inductance is connected across the variometer on range thirteen by the operation of one of the switch arms. A star cam on the same network switch shaft operates a switch (S113D) that incapacitates the RF portion of the complete transmitter by preventing the operation of the keying relay, K102, between the network switch settings.

(7) Autotune unit "E" controls the setting of the large variable loading capacitor, plus the operation of a switch in the network switch assembly controlled by a cam attached to the variable capacitor rotor. This switch extends the range of the large variable loading capacitor by connecting three ceramic capacitors located in the network switch assembly as padders.

## SECTION V MAINTENANCE

### 1. GENERAL.

This radio equipment has been constructed of materials considered to be the best obtainable for the purpose and has been carefully inspected and adjusted at the factory to reduce maintenance to a minimum. However, a certain amount of checking and servicing will be necessary to maintain efficient and dependable operation. The following procedures should aid in the checking and servicing of the equipment.

### 2. PREFLIGHT OPERATIONAL CHECK.

*a.* Before each flight the operation of the transmitter should be checked.

*b.* The following operational checks will indicate whether or not the transmitter is operating normally.

(1) Place the CALIBRATE - TUNE - OPERATE switch, S106, in the OPERATE position. Rotate the EMISSION selector switch, S110, to the CW position (applies 1150 volts dc plate potential). After allowing the tubes at least one minute to warm up, operate the TEST switch, S104, to the ON position.

(2) Check the P.A. PLATE meter reading. Refer to Section II, paragraphs 2., b., (1), (z) and 2., b., (3), (u).

(3) Release the TEST switch and place S110 in the VOICE position.

(4) Insert a microphone cord plug into the MICROPHONE jack, J102, press the push-to-talk switch (applies 1150 volts plate potential) and while speaking into the microphone observe the P.A. PLATE meter needle "kick". Check the position of the microphone switch, S201, to make certain that it is in the proper position for the type of microphone used.

(5) Check the keying on CW and MCW by listening to the output of the sidetone amplifier and to the keyed signal on an adjacent receiver.

(6) Check keying using LOCAL control and an external key. Also check keying with REMOTE control and the key located on the Pilot's Control Box.

*c.* If the above checks indicate normal transmitter operation, no further tests will be necessary.

*d.* If transmitter operation does not appear to be normal, check the (1) position of the power level switch, S106, (2) position of the EMISSION selector switch, S110, (3) position of the LOCAL-REMOTE switch, S107, (4) position of the metered circuit selector switch, S105, (5) dynamotor fuse, (6) dynamotor operation, (7) battery voltage, (8) cable connector plugs, (9) antenna and ground connections, and (10) position of Controls "A" and "C".

*e.* If the above checks fail to reveal the cause of erratic operation or transmitter failure, further trouble shooting will be necessary. The trouble shooting procedure together with the symptoms of and cures for some of the more common causes of erratic operation or transmitter failure is outlined in this section of this book under SERVICING.

### 3. ROUTINE CHECK.

*a.* To assure efficient and dependable service, periodic operational checks should be made. The inspection and check should be made at intervals of approximately one month or during the regular inspection of the airplane.

*b.* The following routine checks are recommended, others may suggest themselves to the maintenance personnel.

#### (1) EQUIPMENT INSPECTION.

(*a.*) Check all interconnecting wires. If necessary hand-tighten all plug locking rings. Inspect for broken and loose wires at the plugs.

(*b.*) Check the connections to the receiver antenna, ground and loading coil, making certain that the spring connector terminals are making good contact with the wires.

(*c.*) Remove the end bells from the dynamotor and, using compressed air, blow out all carbon and copper dust from the commutator and surrounding surfaces. Inspect the brushes for wear and replace them if the carbons are shorter than  $\frac{1}{4}$  inch. No lubrication of the dynamotor bearings is necessary as the bearings are sealed for the life of the unit.

(*d.*) All relays should be carefully checked at regular intervals. Check the contacts for proper alignment, pitting and corrosion. Use a burnish-

ing tool to clean the contacts—never use sandpaper or emery cloth.

(2) OPERATIONAL CHECKS.

To check the operation of the Autotune system, proceed as follows:

(a) Place the power level switch, S106, in the TUNE position and the EMISSION selector switch, S110, in the VOICE position.

(b) Beginning with Channel 1 operate the CHANNEL selector switch, S108, to each of the ten high-frequency channels. As each Autotune cycle is completed, check the positions of the controls against their original settings.

(c) Having checked the positioning of the ten high-frequency channels, operate CHANNEL selector switch S108 to the L. FREQ. position.

(d) When the Autotune cycle has been completed Control "A" should come to rest in Position 13.

(e) After checking that the Autotune positions correctly for the eleven channel positions, operate S108 to the MANUAL position.

(f) When the Autotune cycle has been completed, check the operation of all controls. Each control should move freely to permit transmitter tuning without disturbing the positions of the Autotune stop rings.

**Note**

To check the operation of the power control, RF and audio circuits, proceed as follows:

(g) Operate the LOCAL-REMOTE switch, S107, to the LOCAL position and the EMISSION selector switch, S110, to the CW position. (Applies 1150 volts dc plate potential.)

(h) Place the metered circuit selector switch, S105, in the P. A. PLATE position.

(i) Operate the TEST switch, S104, to the ON position.

(j) Check the power amplifier plate reading on meter M102. The meter should indicate current within the CW portion of the meter scale.

**Note**

If M102 does not indicate a P.A. PLATE meter reading within the CW portion of the scale some adjustment of the output loading may be necessary. Before attempting to readjust the output circuit for proper loading for the particular channel upon which the transmitter is operating, check the operation on the

other Autotune channels by operating the CHANNEL selector switch, S108.

(k) If all meter readings are off in the same direction, that is, if all readings are too high or if all readings are too low, check the battery voltage by operating the metered circuit selector switch, S105, to the BATTERY position.

**Note**

If the battery voltage is much higher or lower than the voltage was at the time that the tuning adjustments were made and the Autotune stop rings locked, the power amplifier plate meter reading will be somewhat different than the original reading. No adjustment of the output tuning controls should be attempted if the tuning adjustments were originally made with normal supply voltage.

(l) Release the TEST switch and insert a key cord plug into the KEY jack, J103. Check the keying by operating the telegraph key and listening to the keyed signal in a receiver. The transmitter should key cleanly and without noticeable chirp at speeds up to thirty words per minute.

(m) Release the telegraph key and place the EMISSION selector switch, S110, in the MCW position. (Applies 1150 volts dc plate potential.)

(n) Place the TEST switch, S104, in the ON position.

(o) Check the P.A. PLATE meter reading on meter M102. The meter should indicate within the MCW portion of the meter scale.

(p) Release the TEST switch and insert the earphones cord plug into the SIDETONE jack, J104.

(q) Insert the key cord plug into the KEY jack, J103.

(r) With the earphones in position, operate the telegraph key and check the keying by listening first in the earphones and then in an adjacent receiver. The keying should be clean-cut and with little distortion of character at keying speeds up to thirty words per minute.

(s) Release the telegraph key and operate the EMISSION selector switch, S110, to the VOICE position.

(t) Insert the microphone cord plug into the MICROPHONE jack, J102.

(u) Press the push-to-talk button on the microphone (applies 1150 volts dc plate potential) and check the P.A. PLATE meter reading.



(v) Check the modulation by pressing the push-to-talk button on the microphone (applies 1150 volts dc plate potential) and speaking into the microphone at normal voice level and checking the swing of the needle of meter M102. The needle should swing up to the MCW portion of the meter scale, or slightly beyond, on voice peaks.

(w) Check the operation of the speech amplifier by listening to the sidetone amplifier output while having someone speak into the microphone.

**Note**

When operation from the LOCAL position has been checked, the procedure outlined below should be followed to check remote operation:

(x) Operate the LOCAL-REMOTE switch, S107, to the REMOTE position.

(y) Operate the EMISSION selector switch, S602, in the Type C-87/ART-13 or C-740/ART-13 Pilot's Control Box, to the VOICE position.

(z) Following the procedure outlined for checking the Autotune system from the transmitter panel, check the operation and positioning of the dials when using the CHANNEL selector switch, S601. The position of the controls for a given Autotune channel selected with S601 should correspond to the position of the controls when the Autotune channel is selected with the panel switch, S108.

(aa) On the C-87/ART-13 Pilot's Control Unit, insert a microphone cord plug into microphone jack J602. If the C-740/ART-13 Pilot's Control Unit is being used, insert the microphone cord in nearby jack box J22/ARC-5 or equivalent. Check the transmitter control by operating the push-to-talk button on the microphone (applies 1150 volts dc plate potential). Also check the condition of the audio lines from the Control Unit to the transmitter by speaking into the microphone and checking the kick of the needle of meter M102. Voice peak readings should correspond to readings obtained when checking the modulation with panel or LOCAL transmitter control.

(bb) Operate S602 to the CW position (applies 1150 volts dc plate potential) and operate the key, S603. Check the keying by listening to the signal on a receiver.

(cc) Operate S602 to the MCW position (applies 1150 volts dc plate potential) and check P.A. PLATE by observing M102. Check the keying by listening to the keyed signal on a receiver.

*Revised 1 May 1953*

#### 4. SERVICING.

##### a. GENERAL.

(1) If the above checks reveal erratic or abnormal operation, the tubes should be carefully checked. Tube failure is probably the most common cause of transmitter failure. The most dependable method of checking the tubes and of finding the defective tube is to replace the tubes one at a time, with tubes known to be in good condition.

(2) In case of trouble, look for simple causes first. Analyze and isolate the difficulty before attempting to remove or dismantle any part of the equipment.

A few moments of thought and study of the complete schematic circuit diagram (figure 8-11, page 8-19, 20) together with a tabulation of the various possible causes of failure, may save hours of haphazard labor.

Radio equipments are often damaged by needless disassembly and removal of parts, when the real cause of trouble is merely a broken lead or a faulty connection.

(3) In order to gain access to the tubes and other components the transmitter cover must be removed. This can be done by inserting a coin or a screwdriver in the holddown screw, making a half turn counterclockwise and lifting off the cover.

b. VACUUM TUBE REPLACEMENT.—After having made certain that the KEY, MICROPHONE and Throttle Switch circuits are open remove the transmitter cabinet cover.

#### CAUTION

In the interest of safety, and to protect other filaments and filament resistors that may be in the circuit, the equipment should be completely turned off when tubes are being replaced.

(1) The tube clamps used in this equipment are designed to prevent the tube from coming out of the socket under vibration incident to normal service. Refer to the tube placement diagram, figure 2-3, page 2-2, for the exact location of the various tube clamps. The clamp on tube V101 is readily accessible through the side cover plate. The clamps on V105 and V106 are accessible through the rear cover plate. The clamps on V102 and V103 can best be reached from the top of the transmitter.

(2) To open or close a clamp in removing or replacing tubes insert a screwdriver as shown in

the lower left corner illustration of figure 2-3, page 2-2. Gently press the clamp open or closed as required. No undue exertion is necessary in operating this type of clamp. Removal of 813 power amplifier tube V104 is facilitated by inserting a screwdriver through a ventilating hole in the rear cover plate so that the screwdriver may be used as a lever between the tube base and the socket.

(3) The 813 tube should be inserted by orienting the base pin with the slot in hole above the socket and pressing down firmly until the tube snaps solidly in the socket.

(4) Study the tube-heater circuits (*see figure 4-2, page 4-4*) to become familiar with the series-parallel arrangement used. This is important to prevent the needless replacement of tubes.

(5) Usually an open filament in a tube will break the filament circuit of another tube. An open filament circuit in the low frequency oscillator or dummy unit will place an abnormally high voltage on the High-Frequency oscillator tube, V101. Occasionally, the metal tubes contain foreign matter which may be "weld-flash" loosened under prolonged vibration. This causes interelectrode short circuits which are sometimes difficult to find because of their temporary nature.

(6) The RF ammeter, M101, is calibrated on 2000 kc at the factory using a "dummy" antenna load comprising 10 ohms and 100 micromicrofarads. The calibration will hold approximately throughout the range of the transmitter. However, since the reading of this meter is dependent upon the impedance of the antenna being used and the operating frequency, the reading will be high when the antenna presents a low impedance and low when the antenna presents a high impedance.

c. VACUUM TUBE FAILURE SYMPTOMS.—Some of the more common symptoms of tube failure together with the tubes that may need replacement are given in the paragraphs that follow:

(1) NO RF OUTPUT IN THE FREQUENCY RANGE 2.0 M TO 6.0 MC.—Three RF tubes are in use when the transmitter is operating in the frequency range 2.0 MC to 6.0 MC, namely V101, V102, and V104. To find the particular tube that is defective replace each tube with another tube of the same type that is known to be in good condition, that is, replace one tube at a time. After each tube replacement check transmitter operation. If, after having replaced all three tubes the transmitter is still inoperative or low in output, further trouble shooting will be necessary.

(2) NO RF OUTPUT IN THE FREQUENCY RANGE 6.0 MC TO 18.1 MC.—When operating in the frequency range 6.0 MC to 18.1 MC a fourth RF tube, V103, is brought into operation. If after having found satisfactory transmitter operation in the frequency range 2.0 MC to 6.0 MC, the output is discovered to be low or nil in the frequency range 6.0 MC to 18.1 MC, the trouble is likely in the 2nd multiplier stage. Replace the type 1625 tube, V103, with a tube of the same type known to be in good condition and check the operation. If the transmitter is still inoperative or the output low, the trouble is something other than a defective tube.

(3) NO RF OUTPUT L.F. CHANNEL (200 kc to 600 kc or 200 kc to 1500 kc).—When the transmitter is operating in the low-frequency range only two RF tubes are used, the LF Oscillator tube, V401 or V2601\*, and the P.A. tube, V104. If output in the frequency range 2.0 MC to 18.1 MC is satisfactory but no output is obtained when the low-frequency channel is selected, the trouble is probably in the low-frequency oscillator stage. Replace V401 or V2601\* with a tube of the same type known to be in good condition and check transmitter operation. If the stage is still inoperative further tests will be necessary.

(4) SATISFACTORY VOICE OPERATION—NO MODULATION ON MCW.—The same audio amplifier and modulator stages are employed for both VOICE and MCW operation, therefore, if no modulation is obtained on MCW, the MCW Oscillator tube, V2203, must be inoperative. Replace V2203 and while listening to the output of the sidetone amplifier or to the signal in a receiver, operate the TEST key and check the modulation. If the signal is still unmodulated it will be necessary to check the oscillator circuit.

(5) SATISFACTORY RF OUTPUT AND SIDETONE AMPLIFIER OUTPUT—NO MODULATION ON EITHER VOICE OR MCW.—THE output of the audio driver tube, V202, is coupled to the input of the sidetone amplifier. Therefore, satisfactory output from the sidetone amplifier indicates that the audio amplifier and audio driver stages are operating satisfactorily. The output of the audio driver is also coupled through a transformer to the grids of the modulator tubes, V105 and V106. Replace the modulator tubes with tubes known to be in good condition, one at a time, and check the transmitter output for modulation. If the RF signal is still unmodulated the trouble is other than defective tubes and further trouble shooting will be necessary.

(6) SATISFACTORY RF OUTPUT — NO MODULATION VOICE OR MCW—NO OUTPUT FROM SIDETONE AMPLIFIER.—There being no output from the sidetone amplifier, it is evident that one or more of the following three stages is inoperative, audio amplifier (V201), audio driver (V202), or the sidetone amplifier (V203). Replace V201, V202 and V203 with a tube of the proper type that is known to be in good condition, one at a time, and while listening to the SIDETONE output, operate the TEST switch after each tube is replaced.

(7) SATISFACTORY RF OUTPUT — SATISFACTORY VOICE AND MCW OPERATION WHEN OPERATING IN CALIBRATE POSITION NO BEAT NOTE OBTAINABLE BETWEEN RF OSCILLATOR OUTPUT AND CALIBRATION OSCILLATOR OUTPUT.—Satisfactory VOICE and MCW operation indicates that the RF, audio and MCW oscillator stages are operating properly, therefore, the trouble must be in the calibration oscillator circuit. Remove calibration oscillator tubes, V2201, V2202, V2203, and crystal Y2201 one at a time, and replace with others known to be in good condition. If it is still impossible to obtain a beat note between the two signals, the trouble is still likely in the calibration oscillator circuit but is something other than a defective tube.

(8) LOW RF OUTPUT.—If the grid meter reading is satisfactory and the transmitter is otherwise apparently operating satisfactorily, note the extent to which the P.A. PLATE meter reading soars off resonance with power level switch S106 in the OPERATE position. Failure of the P.A. PLATE meter reading to soar more than 10% usually indicates low emission of the 813 final amplifier tube, V104. Normal off reso-

nance P.A. PLATE meter reading will be found to be about 200. If it appears that the off resonance reading is considerably more than 200 the 813 tube will usually be found to be "soft" or "gassy".

(9) HIGH DISTORTION ON VOICE.—Replace the 813 tube if after checking the speech amplifier tubes, the unit itself and the modulator tubes, V105 and V106, high distortion exists at full modulation. Since both the screen and the plate of the tube have separate modulation transformer windings it is possible for a condition to exist where the proportion of current drawn by the 813 screen and plate is not normal. This condition can cause a mismatch to occur in the modulation transformer at high audio levels.

*d.* TROUBLE SHOOTING.

(1) GENERAL.

(a) If replacing vacuum tubes has failed to remedy the trouble and the transmitter is still inoperative or not operating properly, further trouble shooting will be necessary.

(b) A few tools and an indicating instrument are absolutely essential. In addition to the tools ordinarily available (screwdriver, pliers, soldering iron, etc.) a volt-ohmmeter capable of measuring dc voltages up to 1500 volts is necessary. Any voltmeter having high internal resistance (1000 ohms or more per volt) will suffice but a meter of the vacuum tube type is recommended. High voltage circuits should not be checked with a voltmeter unless other means cannot be used. This practice is advocated in the interest of safety.

(c) The following table of typical servicing problems should prove useful in locating common sources of trouble:

TYPICAL SERVICING PROBLEMS OTHER THAN THOSE COMMONLY CAUSED BY  
VACUUM TUBE, CAPACITOR OR RESISTOR FAILURES.

SYMPTOM

PROBABLE CAUSE

<p>Overload relays will not remain in the operated position.</p>	<p>28 volt or high voltage short in the equipment. Weak tension of spring in overload relays (Klixsons K2103 or K2104).</p>
<p>28 volt short.</p>	<p>Autotune cover touching a lug on Autotune limit switch section S111. Autotune limit switch contact arms touching multiturn unit. Terminals of motor control relay K101 shorted due to cable pressure against relay. Autotune motor B101 defective. Lug on R116 touching chassis. Lug on keying interlock switch S113D touching chassis.</p>
<p>Fuse F2101 blown. 400 volt short in Multiplier Unit.</p>	<p>400 volt short. Cable wire caught on an arm of range switch S103. Cable shield touching lug of C115. L105 slug shorting on pin of L105 internally. L106 slug shorting on pin of L106 internally. S101 cam follower arm not centered on star cam resulting in the arm contacting a mounting screw of a contact spring of range switch S102.</p>
<p>400 volt short not in multiplier.</p>	<p>Ground bus on X104 socket touching 813 tube V104 series screen resistor R112 tie point. Lug on R113 touching chassis. Lug on R105 touching chassis. Short in connections to J111. Wires pinched underneath Modulation transformer T101.</p>
<p>High voltage short.</p>	<p>Center grounding lead of CW relay K103 touching contact springs.</p>
<p>No output from High Frequency Oscillator.</p>	<p>Improper contact on oscillator selecting switch S114. Improper contact on keying relay K102.</p>
<p>Absence of beat notes at sidetone output.</p>	<p>Cable connections on J111 broken or shorted. Cable connections on J114 broken or shorted.</p>

<p>No output from first multiplier stage.</p>	<p>First multiplier plate choke L115 open.</p> <p>Incorrect adjustment of, or foreign matter on, the contacts of range switch, S102.</p> <p>A section of padding capacitor C111 open or shorted.</p> <p>A broken slug or a shorted or open turn on inductor L105.</p> <p>Improper contact on oscillator selecting switch S114.</p> <p>Control grid or screen suppressor resistors R103 or R104 grounded.</p> <p>Dial "A" out of alignment with shaft.</p>
<p>No output from second multiplier stage.</p>	<p>Improper contact on second multiplier cathode switch S115.</p> <p>Incorrect adjustment of, or foreign matter on, the contacts of range switches, S102 and/or S103.</p> <p>A section of padding capacitor C115 open or shorted.</p> <p>A broken slug or a shorted or open turn on inductor L106.</p> <p>Control grid or screen suppressor resistors R106 or R108 grounded.</p> <p>Dial "A" out of alignment with shaft.</p>
<p>Insufficient or absence of grid current reading on meter M102.</p>	<p>813 tube V104 not in the socket properly. 813 tube filament not at full brilliance due to open shunt resistor R123 or defective filament.</p> <p>Multiplier padding capacitors C111 and C115 in need of readjustment due to excessive vibration, humidity or corrosion.</p> <p>Grid choke L107 open or turns shorted.</p> <p>Defective contact on meter circuit selector switch S105.</p>
<p>Erratic operation or frequency instability of High Frequency Oscillator.</p>	<p>Incorrect adjustment of oscillator range switch S101 cam follower.</p> <p>Dial "A" out of alignment with shaft.</p> <p>Loose nut on oscillator lead screw at multiplier slug cross-bar (will necessitate recalibration of oscillator).</p> <p>Multiturn unit loose on casting.</p> <p>Backlash in lead screw bushing.</p> <p>Capacity change of capacitors C101, C102, C103, C104, or C105.</p>
<p>Erratic multiplier operation. Inability to adjust unit properly.</p>	<p>Leads connecting multiplier padding capacitors C111 and C115 touching each other.</p>

<p>Erratic final amplifier operation. Inability to resonate amplifier properly.</p>	<p>Turns shorting on inductance L113 (aggravated at operating temperatures) failure of S113 network switches to make contact due to foreign matter on contacts or binding of switch arm shafts.          Mechanism for the operation of S113A (operated by Dial "E") out of adjustment.          Improper adjustment of vacuum contact S116.          Improper contact adjustment of output circuit selecting relay K105.          Static drain choke L110 or choke L116 open (changes tuning characteristics).          Misplaced bus wiring in network switch causing shorts or arcing.          Open thermocouple in antenna ammeter.          Poor contact of rotor contacts of variometer L112.          Dial "C" out of alignment with shaft.          Incorrect use of antenna shunt capacitor.</p>
<p>813 tube draws plate current with key up.</p>	<p>Cathodes of exciter stages grounded regardless of the operation of keying relay K102.          813 tube V104 screen contact on keying relay K102 not grounding the screen when the key is up.</p>
<p>Spurious RF and AF oscillations.</p>	<p>813 tube V104 beam forming plates not grounded causing self oscillation of the tube.          Shield of first audio amplifier tube V201 not grounded.          Defective audio amplifier unit.          Shield on wires to voice relay K104 or J112 disconnected.          Defective contact on power level switch S106.          Open capacitor C209 or C210.</p>
<p>Abnormal or no modulation.</p>	<p>Defective contact on microphone jack J102.          Microphone selecting switch S201 in wrong position for type of microphone being used.          Defective contact jacks in J112 (a jack pushed up in the housing).          Open, shorted or partially shorted winding on modulation transformer T101.          CW relay contact arm in contact with a lug of capacitor C120A.          Lead of R134 grounded on the frame of power level switch S106.</p>
<p>Abnormal or no modulation only on MCW.</p>	<p>Lead of R135 grounded on the frame of power level switch S106.          Voice relay K104 not making contact.          Broken wire on J111 or J112.          Shield on wires to voice relay K104 touching contact arm terminals of K104.</p>

813 and 811 tubes (V104, V105 and V106) do not light up on VOICE.	Improper contact of 4 and 5 on CW relay K103. Improper contact of 1 and 2 on voice relay K104.
Keying relay K102 energized when key is up.	Shield on wires to voice relay K104 touching contact arm terminals of this relay.
Sidetone output low or absent entirely. Volume increased by turning sidetone output control S202 counterclockwise.	A ground in the sidetone circuit (especially in remote control cabling or connections).
Sidetone pitch varied by adjustment of sidetone output control S202.	Remote connections 23, 24 and 25 shorted in either position of keying relay K102 (key up or down).
Abnormal operation of output circuit selecting relay K105.	Faulty operation, or shorting terminals on oscillator selecting switch S114.
Autotune hesitates at moment of reversal accompanied by clicking of keying relay K102.	Improper contact or shorting terminals on limit switch section S111.
Unusual clicking noise during Autotune operation.	Probably a stiffened joint in chain drive.
An Autotune Unit locks when the Autotune system is in the MANUAL position.	Unit is probably out of synchronization.
Autotune channel is selected, but motor does not start.	Foreign matter on contacts of motor control relay K101.
Autotune system will not reverse.	Improper contact on limit switch section S112, CHANNEL selector switch S108 or Seeking switch S109.
Autotune completes cycle but dynamotor does not start.	Probably poor contact of limit switch section S111 or dynamotor input relay K2101.
An autotune unit will not reposition.	Broken pawl spring. Foreign matter in the Autotune system. Anvil inoperative (on multiturn unit).
Erratic channeling of Autotune system.	Probably an intermittent contact on the circuit from CHANNEL selector switch S108 to J106 or seeking switch S109.

**Notes**

Look for open, shorted or partially shorted chokes and other inductances. Inspect capacitors for shorts, intermittent shorts or opens.

Inspect resistors for opens or wrong values.

Look for faulty connections or pieces of solder or wire which might cause short circuits.

If the foregoing tests do not reveal the source of trouble, refer to figure 5-1. Typical Operating Voltage and Current Measurement Chart and figure 5-2. Typical Resistance Measurement Chart.

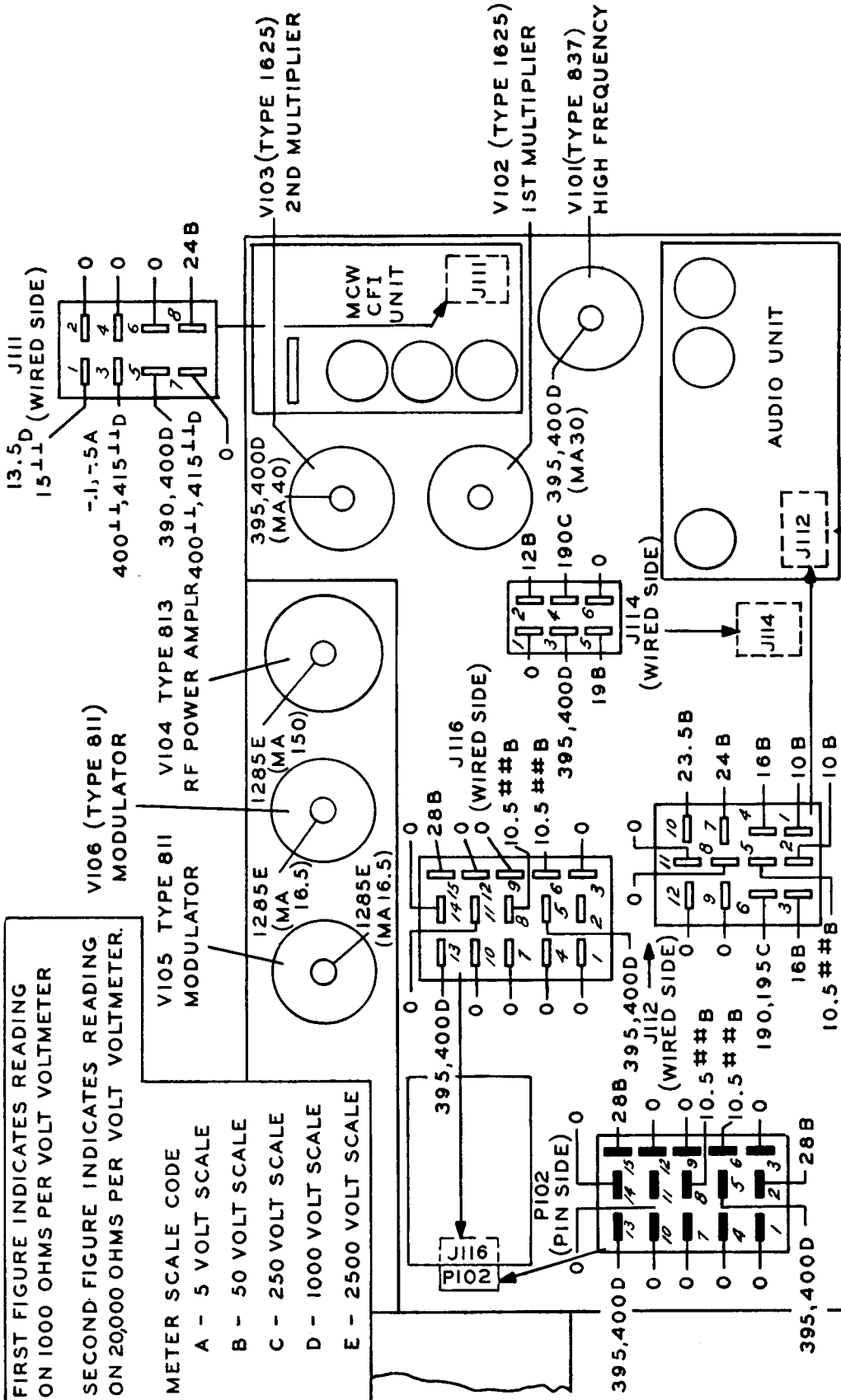

Figure 5-1. Typical Operating Voltage and Current Measurement Chart  
(Sheet 1 of 5 Sheets)



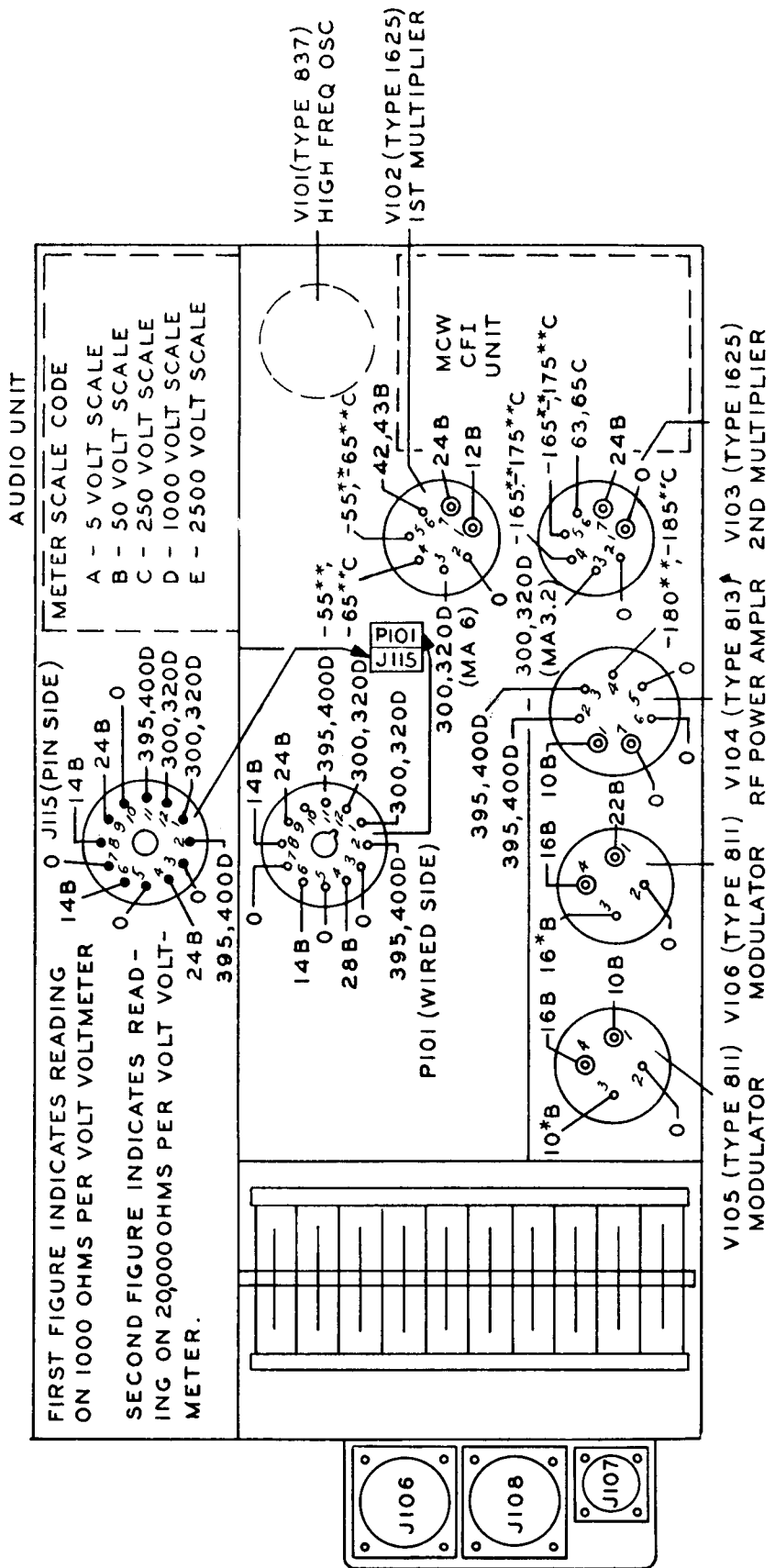
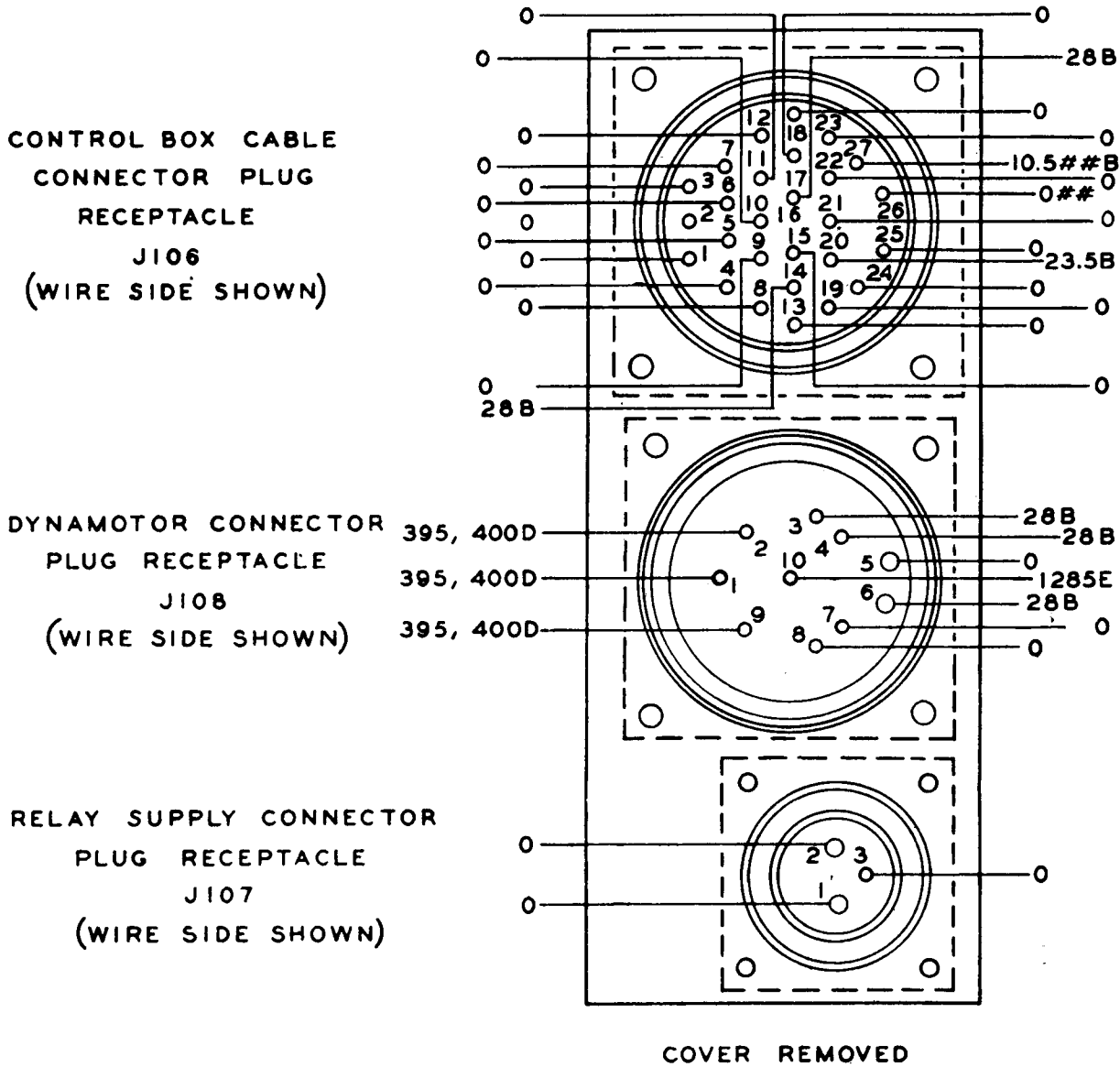

Figure 5-1. Typical Operating Voltage and Current Measurement Chart  
(Sheet 2 of 5 Sheets)

FIRST FIGURE INDICATES READING ON 1000 OHM PER VOLT VOLTMETER.  
SECOND FIGURE INDICATES READING ON 20,000 OHM PER VOLT VOLTMETER.  
METER SCALE CODE: A= 5 VOLT SCALE; B= 50 VOLT SCALE; C=250 VOLT SCALE;  
D=1000 VOLT SCALE; E=2500 VOLT SCALE.



GENERAL CONDITIONS OF MEASUREMENT:

1. ALL VOLTAGE READINGS TAKEN AT FULL POWER LEVEL WITH A SUPPLY VOLTAGE OF 28 VOLTS.
2. ALL VOLTAGES MEASURED TO THE GROUND.
3. TRANSMITTER ADJUSTED FOR MCW OPERATION IN THE RANGE 6000KC. TO 7200KC., LOCAL CONTROL AND KEY CLOSED.

## USE 1000 OHM PER VOLT AC VOLTMETER, SIDETONE SWITCH ON POSITION 5 (OUTPUT OF AUDIO SIDETONE).

Figure 5-1. Typical Operating Voltage and Current Measurement Chart  
(Sheet 3 of 5 Sheets)

AN 08-30ART13-5

NOTE 1: FIRST FIGURE INDICATES READING ON 1000 OHM PER VOLT VOLTMETER. SECOND FIGURE INDICATES READING ON 20,000 OHM PER VOLT VOLTMETER.  
METER SCALE CODE: A=5 VOLT SCALE. B=50 VOLT SCALE. C=250 VOLT SCALE.  
D=1000 VOLT SCALE. E=2500 VOLT SCALE.

NOTE 2: FOR VOLTAGE MEASUREMENT OF FIRST AUDIO AMPLIFIER, PLACE POWER LEVEL SWITCH IN THE CALIBRATE POSITION AND MICROPHONE SELECTING SWITCH IN THE CARBON POSITION.

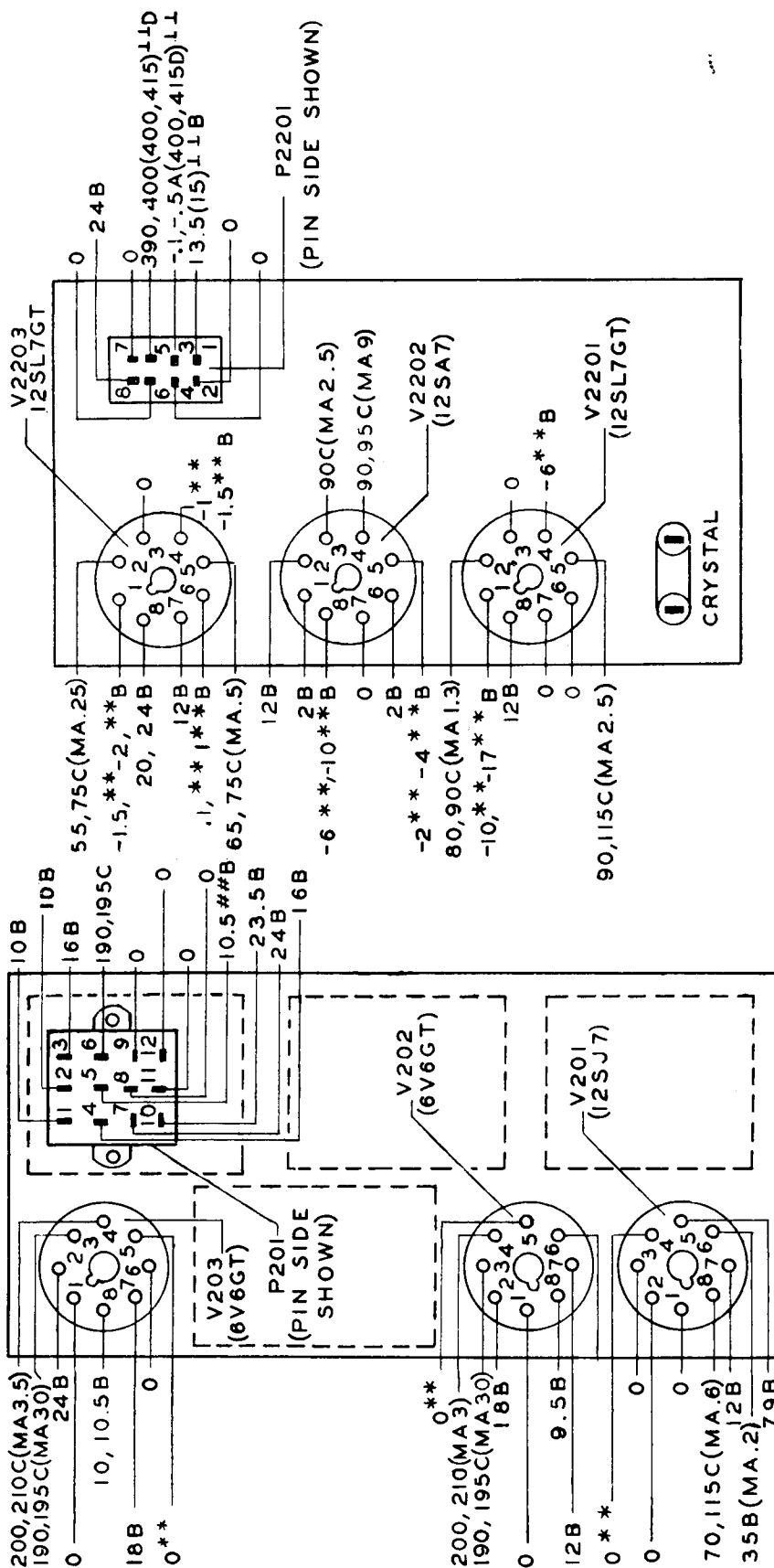

GENERAL CONDITIONS OF MEASUREMENT:

1. ALL VOLTAGE READINGS TAKEN AT FULL POWER LEVEL WITH A SUPPLY VOLTAGE OF 28 VOLTS.
2. ALL VOLTAGES MEASURED TO GROUND.
3. TRANSMITTER ADJUSTED FOR MCW OPERATION IN THE RANGE 6000KC. TO 7200KC., LOCAL CONTROL AND KEY CLOSED.

\* ACTUAL FILAMENT VOLTAGE MEASUREMENT. REFER TO SECTION IV, PARAGRAPH 5., B.  
 \*\* 100 MH RF CHOKE USED TO ISOLATE METER.  
 †† TURN POWER LEVEL SWITCH TO CALIBRATE POSITION FOR THESE READINGS.  
 # USE 1000 OHM PER VOLT AC VOLTMETER. SIDETONE SWITCH ON POSITION 5 (OUTPUT OF AUDIO SIDETONE)

Figure 5-1. Typical Operating Voltage and Current Measurement Chart  
(Sheet 4 of 5 Sheets)

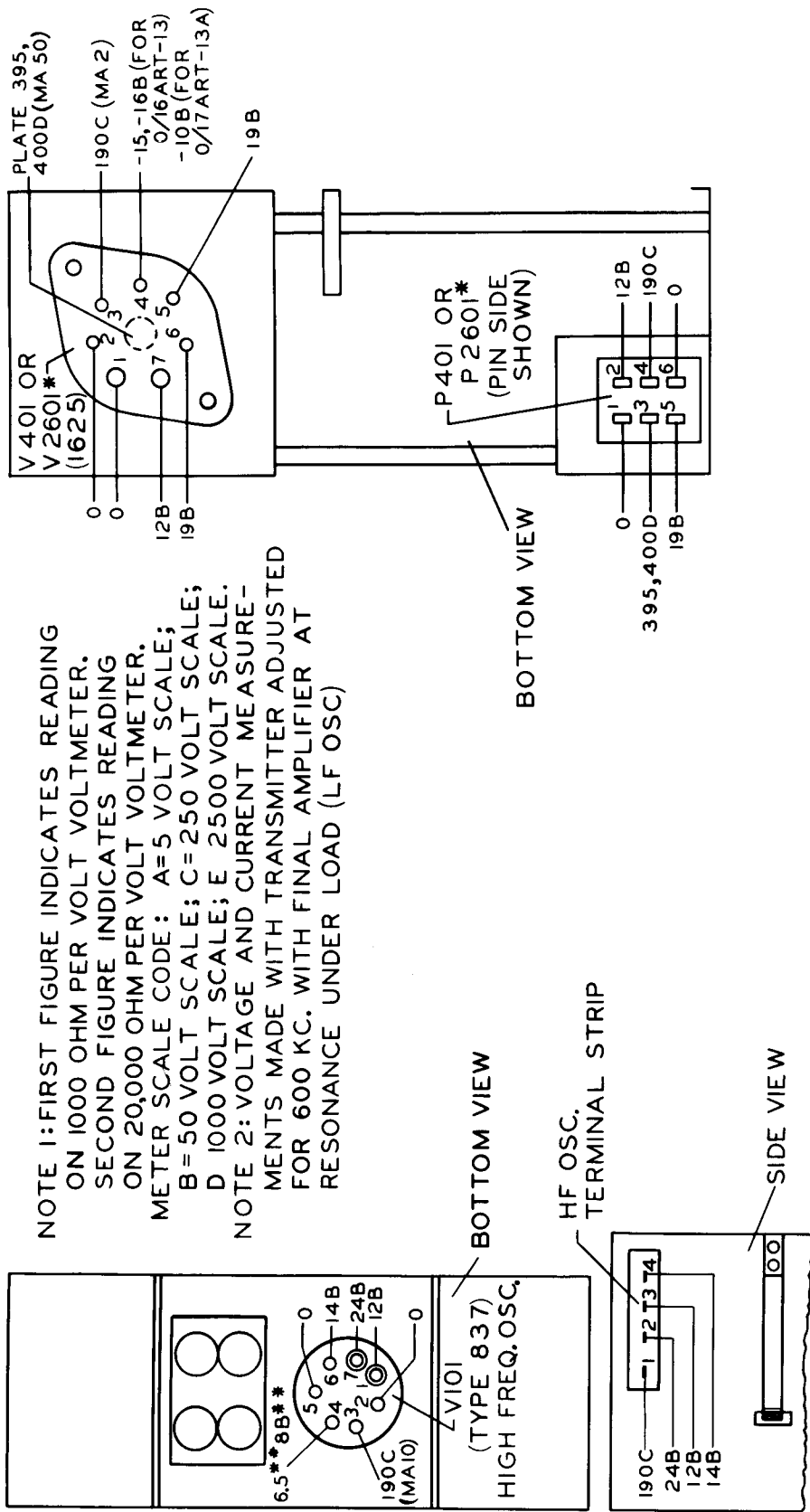

NOTE 1: FIRST FIGURE INDICATES READING ON 1000 OHM PER VOLT VOLTMETER. SECOND FIGURE INDICATES READING ON 20,000 OHM PER VOLT VOLTMETER. METER SCALE CODE: A=5 VOLT SCALE; B=50 VOLT SCALE; C=250 VOLT SCALE; D=1000 VOLT SCALE; E=2500 VOLT SCALE.

NOTE 2: VOLTAGE AND CURRENT MEASUREMENTS MADE WITH TRANSMITTER ADJUSTED FOR 600 KC. WITH FINAL AMPLIFIER AT RESONANCE UNDER LOAD (LF OSC)

**GENERAL CONDITIONS OF MEASUREMENT:**

1. ALL VOLTAGE READINGS TAKEN AT FULL POWER LEVEL WITH A SUPPLY VOLTAGE OF 28 VOLTS.
2. ALL VOLTAGES MEASURED TO GROUND.
3. TRANSMITTER ADJUSTED FOR MCW OPERATION IN THE RANGE 6000 KC. TO 7200 KC., LOCAL CONTROL AND KEY CLOSED.

\* 100 MH RF CHOKE USED TO ISOLATE METER.

Figure 5-1. Typical Operating Voltage and Current Measurement Chart (Sheet 5 of 5 Sheets)

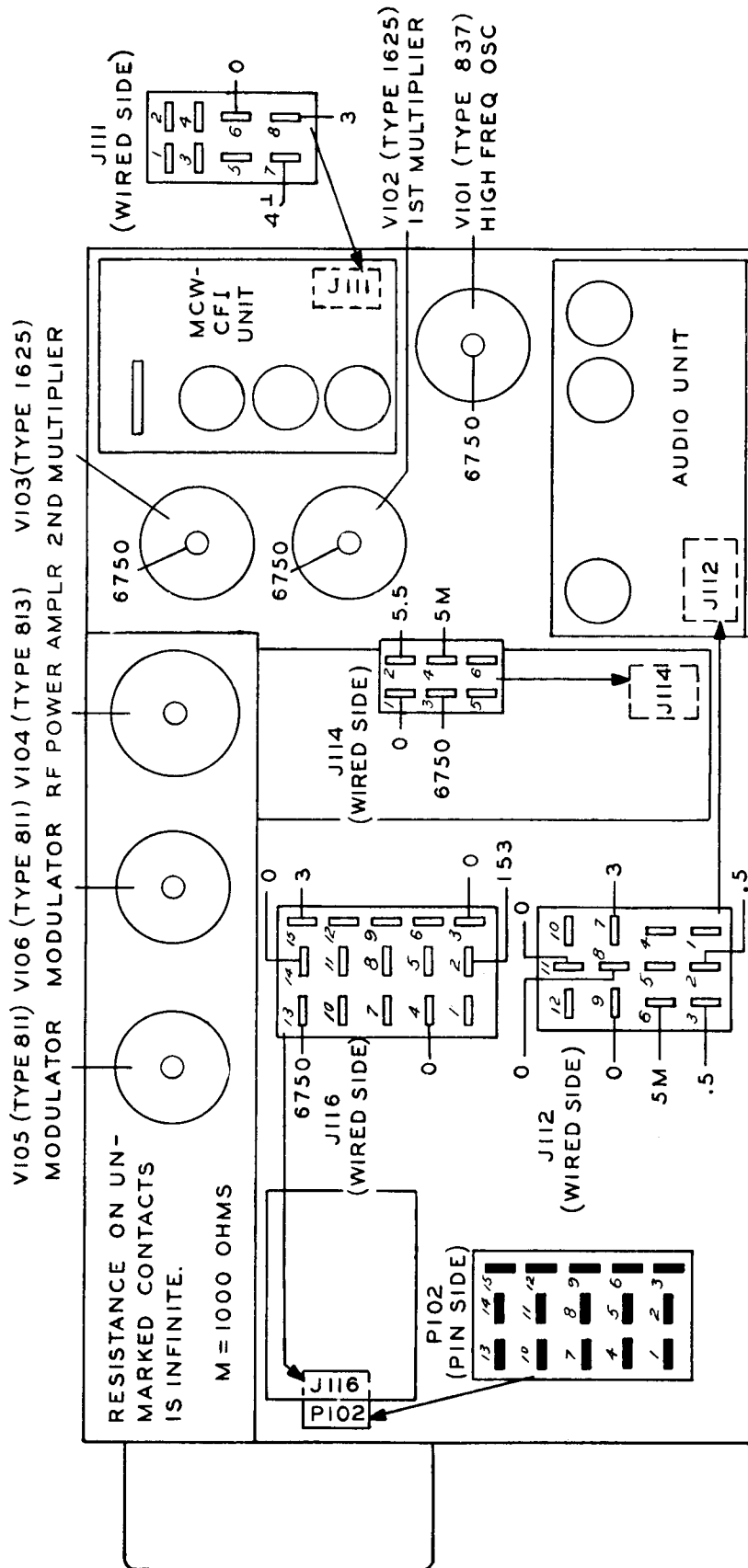

GENERAL CONDITIONS OF MEASUREMENT :

1. ALL RESISTANCE MEASURED TO GROUND
2. ALLOW ONE HALF HOUR TO ELAPSE WITH TRANSMITTER TURNED OFF.
3. TUBES IN PLACE, BUT KEYING RELAY, AUDIO, L.F.O., MCW-CFI, PILOT'S CONTROL AND DYNAMOTOR POWER UNITS DISCONNECTED.

CONDITIONS OF TUBE TERMINAL MEASUREMENTS :

EMISSION SELECTOR SWITCH IN MCW POSITION, CONTROL "A" ON POSITION 7, POWER LEVEL SWITCH ON "OPERATE", UNLESS OTHERWISE NOTED AND KEY CLOSED.

CONDITIONS OF CONNECTOR TERMINAL MEASUREMENTS :

SAME AS ABOVE EXCEPT AUTOTUNE POSITIONED ON CHANNEL 1 AND MICROPHONE CIRCUIT SELECTOR SWITCH IN CARBON POSITION.

1. TURN POWER LEVEL SWITCH TO TUNE POSITION FOR THESE READINGS .

Figure 5-2. Typical Resistance Measurement Chart  
(Sheet 1 of 6 Sheets)

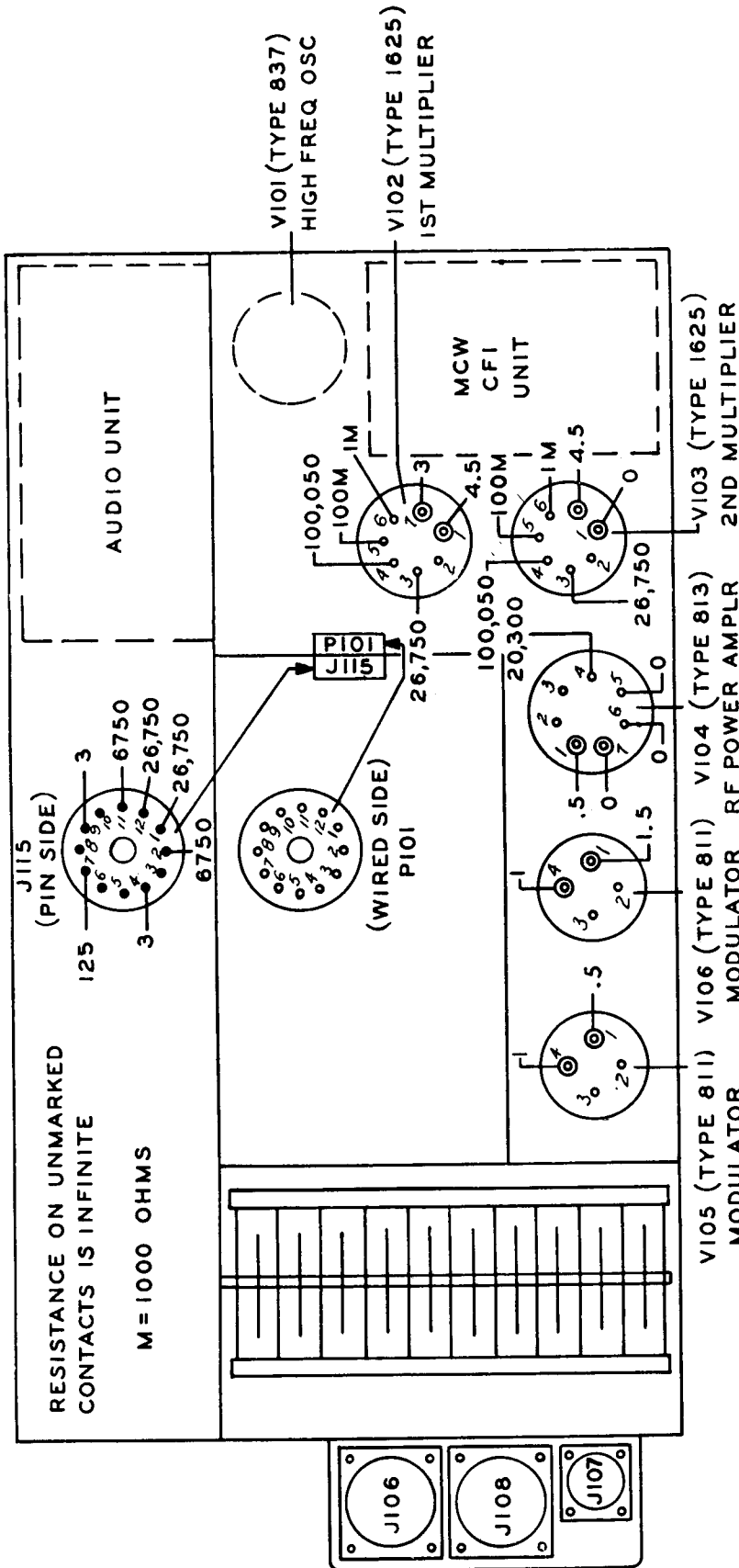

- GENERAL CONDITIONS OF MEASUREMENT :**
1. ALL RESISTANCE MEASURED TO GROUND.
  2. ALLOW ONE HALF HOUR TO ELAPSE WITH TRANSMITTER TURNED OFF.
  3. TUBES IN PLACE, BUT KEYING RELAY, AUDIO, L.F.O., MCW-CFI, PILOT'S CONTROL AND DYNAMOTOR POWER UNITS DISCONNECTED.
- CONDITIONS OF TUBE TERMINAL MEASUREMENTS :**
- EMISSION SELECTOR SWITCH IN MCW POSITION, CONTROL "A" ON POSITION 7, POWER LEVEL SWITCH ON "OPERATE", UNLESS OTHERWISE NOTED AND KEY CLOSED.
- CONDITIONS OF CONNECTOR TERMINAL MEASUREMENTS :**
- SAME AS ABOVE EXCEPT AUTOTUNE POSITIONED ON CHANNEL 1 AND MICROPHONE CIRCUIT SELECTOR SWITCH IN CARBON POSITION.

Figure 5-2. Typical Resistance Measurement Chart  
(Sheet 2 of 6 Sheets)

RESISTANCE ON UNMARKED CONTACTS IS INFINITE.

L = LOCAL.  
R = REMOTE.

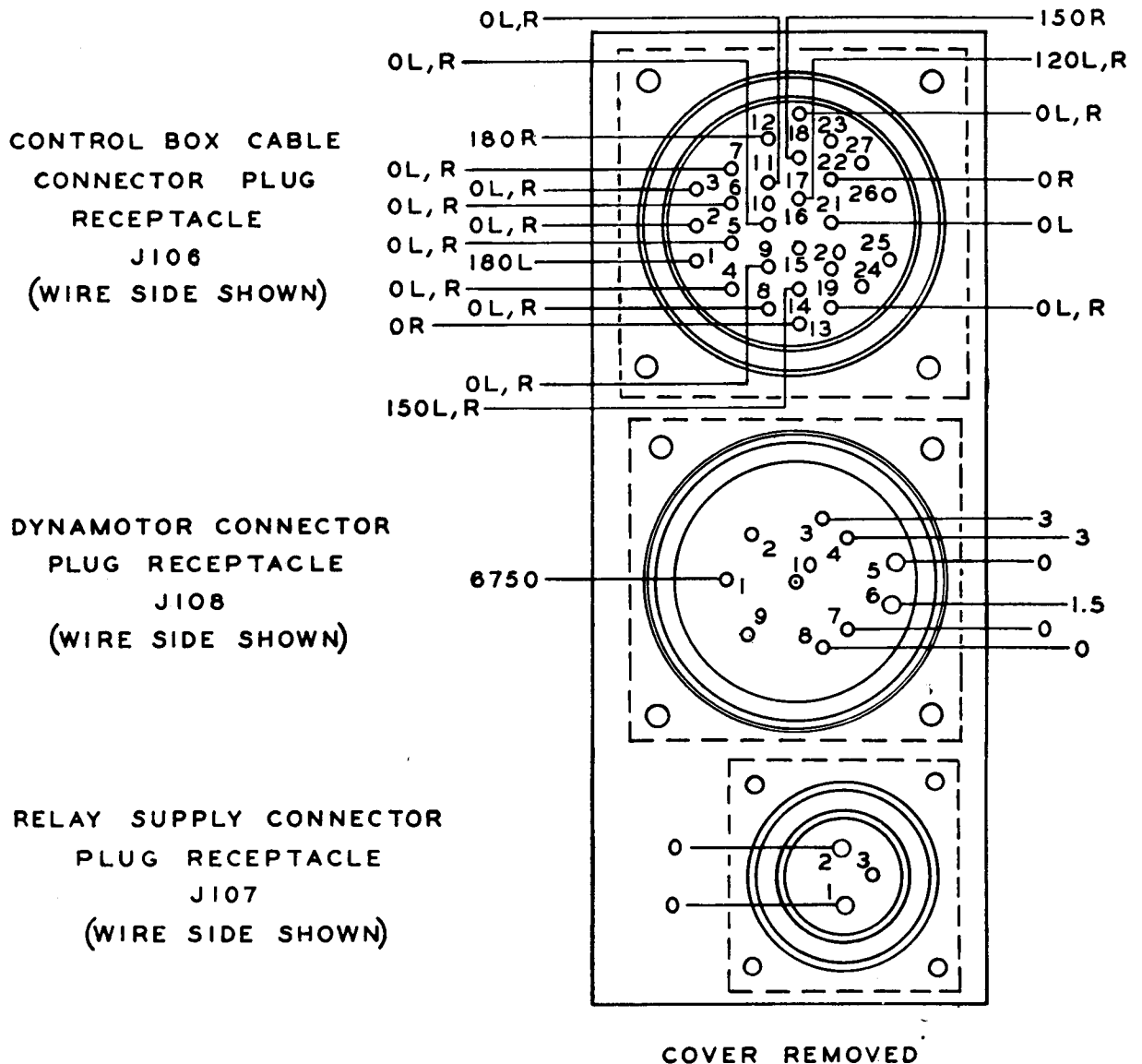

GENERAL CONDITIONS OF MEASUREMENT:

1. ALL RESISTANCE MEASURED TO GROUND.
2. ALLOW ONE HALF HOUR TO ELAPSE WITH TRANSMITTER TURNED OFF.
3. TUBES IN PLACE BUT KEYING RELAY, AUDIO, LFO, MCW-CFI, PILOT'S CONTROL AND DYNAMOTOR POWER UNITS DISCONNECTED.

CONDITIONS OF TUBE TERMINAL MEASUREMENTS:

EMISSION SELECTOR SWITCH IN MCW POSITION, CONTROL "A" ON POSITION 7, POWER LEVEL SWITCH ON "OPERATE" UNLESS OTHERWISE NOTED AND KEY CLOSED.

CONDITIONS OF CONNECTOR TERMINAL MEASUREMENTS:

SAME AS ABOVE EXCEPT AUTOTUNE POSITIONED ON CHANNEL 1 AND MICROPHONE CIRCUIT SELECTOR SWITCH IN CARBON POSITION.

Figure 5-2. Typical Resistance Measurement Chart  
(Sheet 3 of 6 Sheets)

M = 1000 OHMS.  
RESISTANCE ON UNMARKED CONTACTS IS INFINITE.

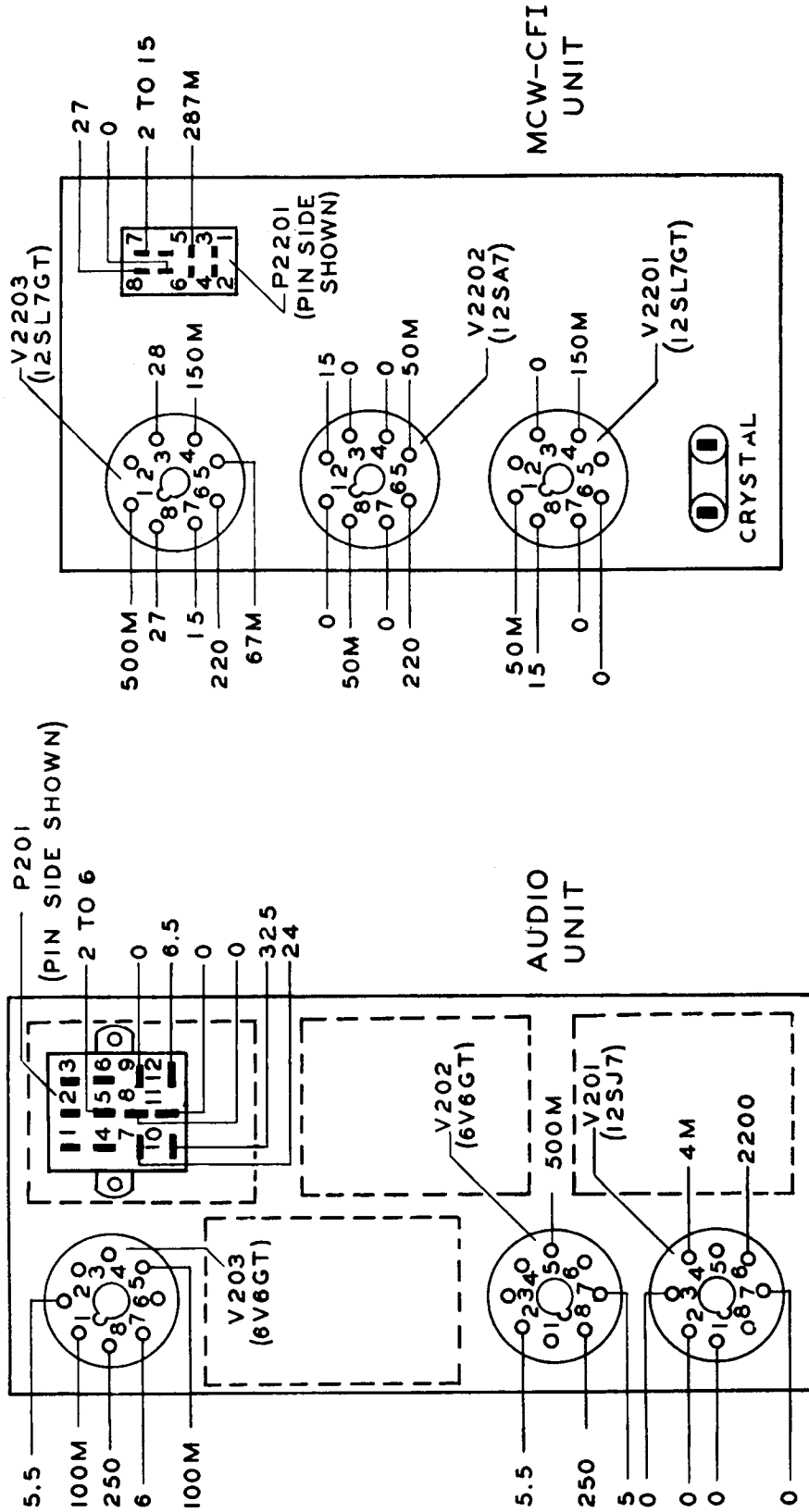

Figure 5-2. Typical Resistance Measurement Chart  
(Sheet 4 of 6 Sheets)

GENERAL CONDITIONS OF MEASUREMENT:

1. ALL RESISTANCE MEASURED TO GROUND.
2. ALLOW ONE HALF HOUR TO ELAPSE WITH TUBES INOPERATIVE.
3. TUBES IN PLACE. UNITS DISCONNECTED AND REMOVED FROM TRANSMITTER.

CONDITIONS OF AUDIO UNIT MEASUREMENTS:

1. MICROPHONE CIRCUIT SELECTOR SWITCH IN CARBON POSITION.



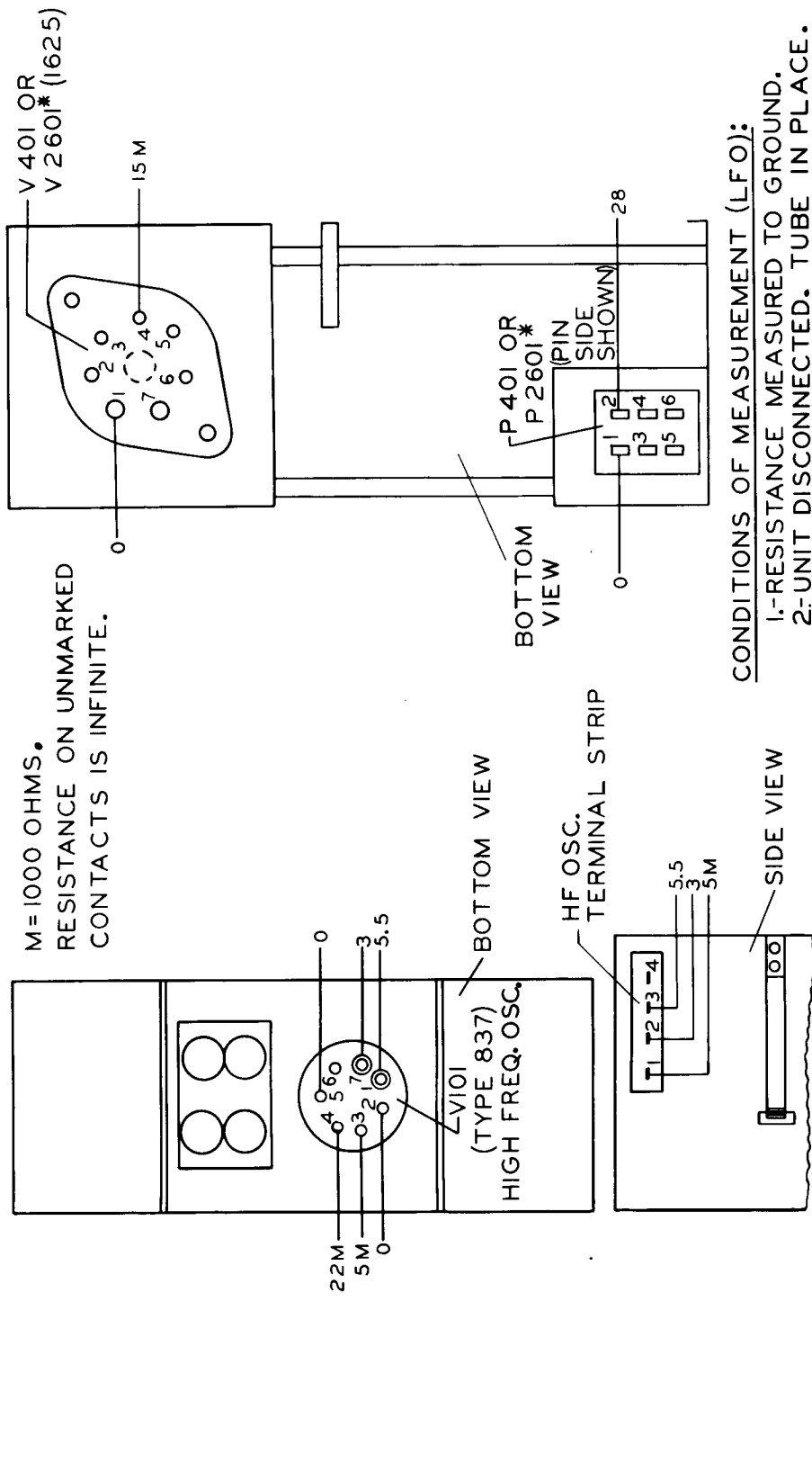

CONDITIONS OF MEASUREMENT (LFO):

- 1.-RESISTANCE MEASURED TO GROUND.
- 2.-UNIT DISCONNECTED. TUBE IN PLACE.
- 3.-TUBE INOPERATIVE FOR ONE HALF HOUR.

GENERAL CONDITIONS OF MEASUREMENT (HFO ONLY):

1. ALL RESISTANCE MEASURED TO GROUND
2. ALLOW ONE HALF HOUR TO ELAPSE WITH TRANSMITTER TURNED OFF.
3. TUBES IN PLACE, BUT KEYING RELAY, AUDIO, LFO, MCW-CFI, PILOT'S CONTROL AND DYNAMOTOR POWER UNITS DISCONNECTED.

CONDITIONS OF TUBE TERMINAL MEASUREMENTS:

EMISSION SELECTOR SWITCH IN MCW POSITION, CONTROL "A" ON POSITION 7, POWER LEVEL SWITCH ON OPERATE UNLESS OTHERWISE NOTED AND KEY CLOSED.

CONDITIONS OF CONNECTOR TERMINAL MEASUREMENTS:

SAME AS ABOVE EXCEPT AUTOTUNE POSITIONED ON CHANNEL 1 AND MICROPHONE CIRCUIT SELECTOR SWITCH IN CARBON POSITION.

Figure 5-2. Typical Resistance Measurement Chart  
(Sheet 5 of 6 Sheets)

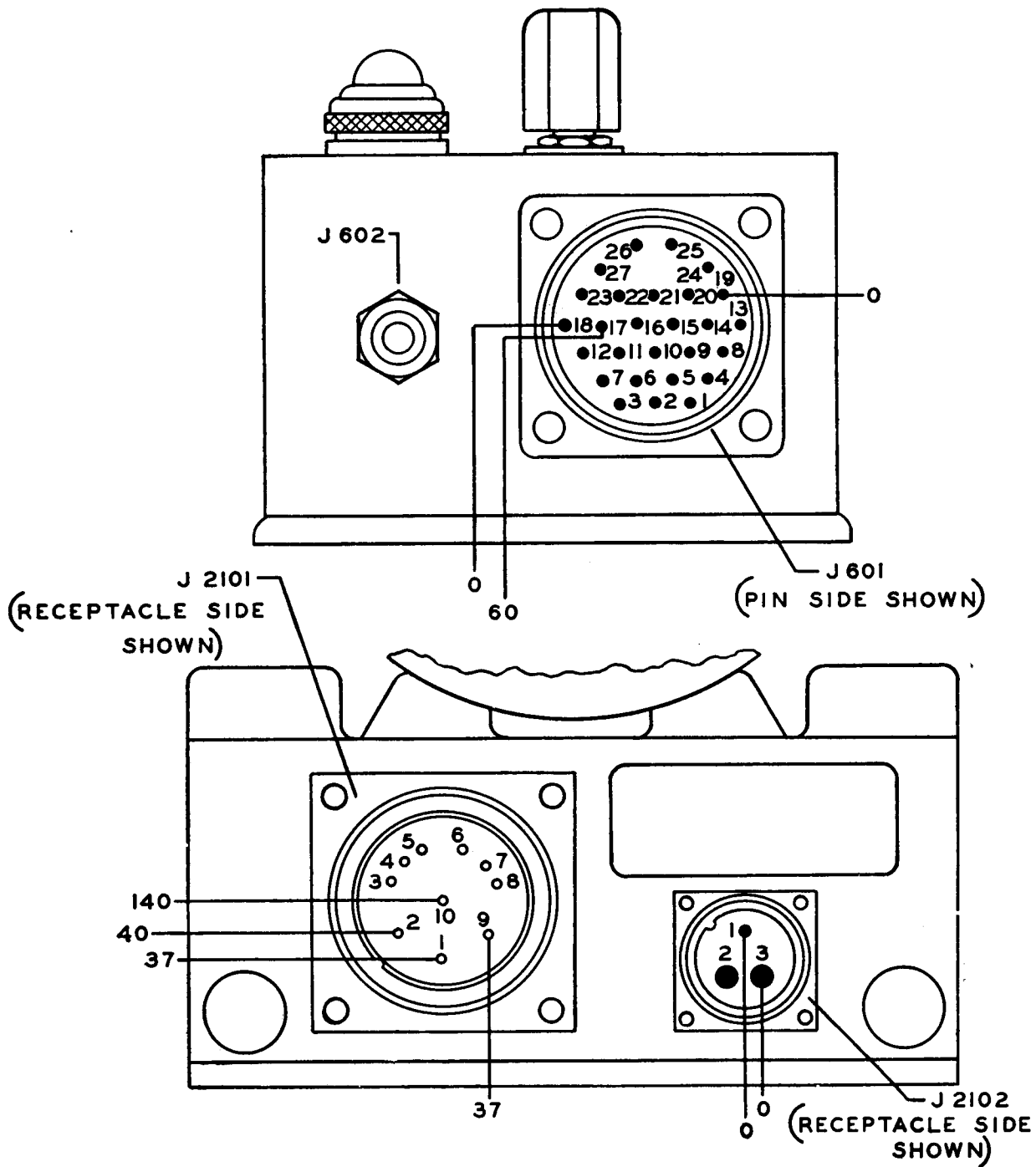

RESISTANCE ON UNMARKED CONTACTS IS INFINITE

GENERAL CONDITIONS OF MEASUREMENTS:

1. ALL RESISTANCE MEASURED TO GROUND.
2. UNITS DISCONNECTED.

Figure 5-2. Typical Resistance Measurement Chart  
(Sheet 6 of 6 Sheets)

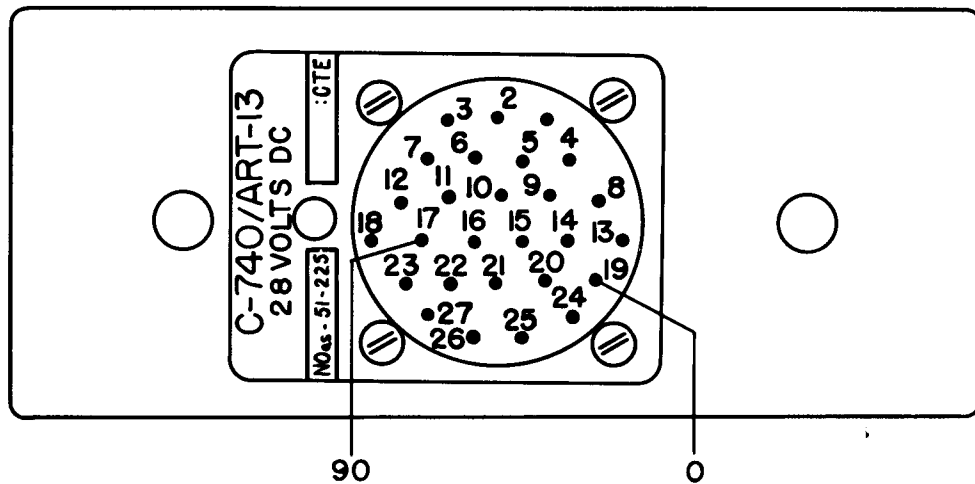

GENERAL CONDITIONS OF MEASUREMENTS :

1. ALL RESISTANCE MEASURED TO GROUND.
2. UNITS DISCONNECTED.
3. RESISTANCE ON UNMARKED CONTACTS IS INFINITE.

Figure 5-2A. Resistance Measurement Chart for C-740/ART-13

Revised 1 May 1953

(2) PILOT'S CONTROL UNIT.—To gain access to the components in the Type C-87/ART-13 Pilot's Control Unit remove the mounting plate. The contacts on the ganged switch sections may require cleaning or if the unit has been exposed to an extreme shock the switch pies may require replacement. The contacts of the telegraph key may require cleaning or the gap between the stationary and movable contacts may require adjustment. To gain access to the C-740/ART-13 Pilot's Control Unit, remove the unit from its rack and take off the back cover. The switch contacts may require cleaning or the switch pies may have to be replaced if defective.

(3) DYNAMOTOR.—There are three sets of brushes in the dynamotor unit. The 28 volt and the 750 volt commutators are located on the end of the dynamotor nearest the connector plugs. If the dynamotor fails to start when the primary circuit is closed the large 28 volt brushes nearest the end of the shaft should be inspected for wear and if the brushes show signs of considerable wear, replacement should be made. If the dynamotor rotates but fails to give the required voltage, remove both end bells from the dynamotor and inspect the high voltage commutator brushes. The brushes may need replacement or copper dust may have accumulated between commutator bars causing short circuiting of some of the segments of the armature. To remove the copper dust use a stream of compressed air. Replace brushes if they are worn down to one-quarter inch or less.

### WARNING

In measuring voltages when the dynamotor is in operation, extreme care should be exercised to prevent personal injury. When operated under normal conditions the positive output circuit of the dynamotor is at a potential of 1150 volts above ground.

(4) POWER CONTROL UNIT.—If replacing brushes and cleaning the commutators fails to return the power unit to normal operation the trouble may probably be traced to the relays in the Type DY-12/ART-13 Power Control Unit. To gain access to these relays loosen the mounting plate clamp nuts on the end of the dynamotor nearest the connector plugs. Remove the power unit from the mounting plate and loosen the four screws in the corners of the control unit that hold the bottom cover plate to the chassis. If the dynamotor fails to rotate when the emission selector switch is rotated to the CW position and the primary brushes and commutators are in good condition possibly the primary power relay,

K2101, has failed to operate or the contacts of this relay are defective. The dynamotor draws considerable current from the power source when operating under full load and therefore it is quite probable that the contacts of this relay will require cleaning more often than any other relay in the equipment. If the filaments of the vacuum tubes fail to light when the emission selector switch is operated to any position other than the OFF position it is quite likely that the relay, K2102, has failed to operate or that the contacts are corroded or pitted. To clean the contacts of these relays always use a burnishing tool—never use sandpaper. If the pressure operated relay, K2106, fails to reduce the voltage to 750 volts when the equipment is approximately 25,000 feet above sea level the entire relay should be replaced. The manufacturer recommends that no attempt be made to replace integral parts of this relay.

(5) ANTENNA LOADING COILS.—The antenna loading coils should require very little maintenance but components such as switches, capacitors and inductors may require adjustment or replacement if the equipment has been subjected to overload or an extreme mechanical shock.

(a) To gain access to the components in the Type CU-25/ART-13 Antenna Loading Coil Unit, loosen the screws on the front panel that hold the cabinet in place and remove the cabinet. Antenna Loading Coil Type CU-32/ART-13A: Remove screws along top and back of cabinet and remove the cover. All components in the unit are mounted on the front panel and base plate. The switch contacts may become corroded and require cleaning. The static drain choke or the capacitor may become defective and cause failure or erratic operation when operating in the frequency range 200 kc to 600 kc. The static drain choke may become open circuited or the capacitor may become shorted. All components are exposed when the cabinet is removed and may be checked with standard test equipment.

(b) If the operation of the equipment in the frequency range 600 kc to 1500 kc becomes erratic or fails entirely it may be due to the failure of some component in the Type CU-26/ART-13 Antenna Loading Coil Unit. To expose the components for inspection or replacement remove unit from mounting plate by loosening the four mounting screws on right-hand side of cabinet.

(6) TRANSMITTER UNIT.—Three of the sub-units in the Type-47/ART-13 Transmitter Unit, the dummy LF unit, the MCW-CFI Unit and the Audio Amplifier Unit, may be readily removed for checking and the replacement of parts. The

three units have been equipped with multi-terminal connector plugs to permit the removal of the sub-units from the transmitter without the use of a soldering iron. The following procedure is recommended for the removal of the above named units:

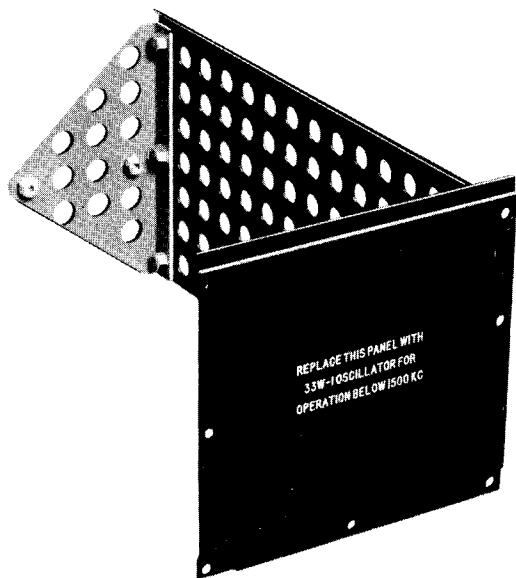

Figure 5-3. Type NX-128/ART-13 Dummy Low Frequency Oscillator Unit—Front View

(a) DUMMY LF OSCILLATOR UNIT.

1. Remove the seven screws that hold the low-frequency panel in place. Refer to figure 5-3.

2. Loosen all screws along the top edge of the Autotune front cover plate.

3. Remove the plate lead from the 813 power amplifier tube, V104, and remove the tube from the socket by inserting a screwdriver through a ventilating hole in the back of the transmitter, using it as a lever between the tube base and the socket. Lift the tube out.

4. Insert a screwdriver through the ventilating holes at the back of the transmitter and remove the screws that hold the back of the unit.

5. The unit is now free of all retaining screws and wires and may be removed from the transmitter by raising the rear edge of the dummy oscillator unit to free the front panel from the Autotune cover plate and then raising the unit until the connector plug is free.

(b) MCW-CFI UNIT.

1. Loosen the two large screws that hold the unit to the main transmitter chassis.

2. Raise the unit until the connector plug is disengaged.

3. Tip the unit toward the frequency multiplier tubes, V102 and V103, until the transformer clears the cabinet cover clamping bracket.

4. Remove the screws holding the sides of the MCW-CFI Unit chassis and pull the sides out as far as the connecting wires will permit.

5. All circuit components are accessible from the bottom of the unit.

(c) AUDIO AMPLIFIER UNIT.

1. Loosen the two large screws that hold the unit to the main transmitter chassis.

2. Remove the plate cap from the high-frequency oscillator, V101, and remove the tube from the socket.

3. Raise the unit until the multi-terminal plug becomes disengaged from the receptacle.

4. Slide the unit backward until the cabinet studs are cleared and raise the audio amplifier unit upward.

(d) HIGH FREQUENCY OSCILLATOR.—

The frequency multiplier plate tank inductors are readily accessible if the cabinet wrap-around plate is removed from the right-hand end of the transmitter cabinet. Four screws in the rear and ten screws on the side hold the plate in position. An additional shield covers the section of the casting that houses the high-frequency oscillator circuit components. If this inner shield is removed all oscillator circuit components will be exposed and available for checking and replacement.

**Notice**

Removal of this inner shield will necessitate oscillator recalibration.

**WARNING**

Do not remove this inner shield or make any adjustments of the HF oscillator condensers or slug unless the calibration of this oscillator is thoroughly understood.

(e) FREQUENCY MULTIPLIER.— Some of the frequency multiplier circuit components are accessible from the bottom of the transmitter when the bottom cover plate is removed. To gain access to the remaining frequency multiplier circuit components, the multiplier unit must be removed from the assembly. The following procedure is recommended for the removal of this unit from the transmitter:

1. Remove the plate caps from the frequency multiplier tubes, V102 and V103, unlock the tube base clamps and remove the tubes from

the sockets. Disconnect the Low Frequency Oscillator plate lead at the Oscillator end.

2. Remove the transmitter bottom cover plate and the Autotune cover plate.

3. Remove Autotune Unit "A" in the following manner: Turn the dial locking bar to the unlocked position and loosen the two #10 Bristo set screws in the dial. Turn the dial and locking bar counterclockwise together until the bar comes free. Remove both the dial and the locking bar. Remove the dial back plate, loosen the two long screws on the top end of the unit and the short screw on the bottom end of the unit. Carefully lift the unit out.

#### CAUTION

Care must be exercised not to move any of the Autotune mechanisms from the time the unit is loosened until the unit is again securely in place, otherwise the unit may be thrown out of synchronization.

4. When the Autotune Singleturn Unit has been removed, remove the screws holding the seeking switch, S109 to the Autotune casting and swing the switch out.

5. Unsolder and remove the wires leading to the multiplier coils at the rear of the High Frequency Oscillator Unit. Unsolder and remove the bus wire connected to coupling capacitor C116.

6. The cam follower arm of High Frequency Oscillator range switch S101 must be removed from the oscillator casting if the multiplier unit is removed. Two Phillips head screws hold this arm on the oscillator casting. Removal of these screws will allow the arm to drop away from the star cam upon which it operates, after which it can be removed from the transmitter.

7. Remove the two screws just behind the second multiplier tube clamp shell and the two screws just in front of the first multiplier tube clamp shell.

8. The multiplier unit can now be pulled out sufficiently to remove the nut holding the ground wire lug on the side of the unit adjacent to the fire wall assembly. Remove cable connector J115 from P101 in the multiplier unit.

9. The multiplier unit may now be lifted out of the transmitter.

10. In reassembling the transmitter it is essential that the shaft of seeking switch S109 be carefully centered with the cam drum shaft that drives it. This may be checked by referring to

paragraph 8., *d.* except that the position of the switch and not the driving arm should be adjusted.

11. In replacing the cam follower arm of High Frequency Oscillator range switch S101, care must be exercised to make certain the end of the arm is centered in the hole provided in the contact arm of the switch. The cam follower arm mounting screws may then be inserted, but not tightened. Because of the fine thread in the aluminum casting, care must be exercised not to cross thread these screws. The arm should then be centered on the star cam mounted on the multiplier switch shaft and the arm mounting screws tightened just enough to hold the arm in place.

12. In order to time the operation of oscillator range switch S101, the following procedure should be followed:

a. Remove the warning plate covering the adjustment holes for C134 and C135 (*figure 5-6, page 5-26*).

b. Connect a continuity indicator from the shaft of C135 (nearest the multiturn unit) to the oscillator casting.

c. Adjust the cam follower until switch S101 indicates continuity on the odd numbered contacts of multiplier range switches S102 and S103 (check with Dial "A"). This should be done in such a manner that continuity is maintained during the fraction of a revolution necessary for the contact arms of multiplier range switches S102 and S103 to travel completely across the flat portion of every odd numbered contact, but not to extend more than the dividing line between the even and the odd numbered contacts.

d. Tighten the cam follower arm mounting screws securely enough to hold the arm in permanent adjustment.

e. If the above conditions cannot be met, the multiplier mounting screws should be loosened and the multiplier moved enough to make the adjustment outlined possible. Retighten the multiplier mounting screws.

#### Note

Care should be exercised to replace the dial exactly as it was before disassembly. Range No. 1 on the dial should correspond exactly with the centering of the contact arms of range switches S102 and S103 on contact 1. In addition, the dial must clear the dial back plate throughout the rotation range of Control "A".

(f) OSCILLATOR CASTING.—The follow-

ing procedure is recommended for the removal of the oscillator casting from the transmitter:

**Notice**

The removal of the High Frequency Oscillator is not recommended unless it is absolutely necessary.

1. Remove the plate cap from the high-frequency oscillator tube, V101, unlock the tube base clamp and remove the tube from the socket.

2. Remove the MCW-CFI and the Audio Amplifier Units as outlined in the preceding section.

3. Remove the two screws that hold J111 the MW-CFI Unit Connector plug receptacle, to the standoffs and unsolder the single wire that connects the high frequency oscillator tube V101 cathode to terminal 1 on J111.

4. Remove the Autotune cover plate and wrap-around section of the transmitter cabinet.

5. Remove the locking bar and dial from Control "A" by turning the dial locking bar to the unlocked position, loosening the two 10 Bristo set screws in the dial, and turning both locking bar and dial counterclockwise until free. Remove the dial back plate.

6. The Autotune Singleturn Unit adjacent to the High-Frequency Oscillator Multiturn Unit must be removed so that the screws holding the oscillator casting to the Autotune casting may be loosened. To remove this unit loosen the short screw that holds the lower edge of the unit to the Autotune casting and the two long screws that hold the upper edge of the unit to the casting and lift the unit carefully out of position.

**CAUTION**

Care must be exercised not to move any of the Autotune mechanisms from the time the unit is loosened until the unit is again securely in place, otherwise the unit may be thrown out of synchronization.

7. When the Autotune Singleturn Unit has been removed, loosen the screws that hold the castings together in the front and top of the chassis.

8. To complete disconnecting the HF oscillator, move the casting slightly to the right and unsolder the connections to the terminal strip on the inner side of the casting and the wires leading to the frequency multiplier plate tank inductors.

9. The HF oscillator casting assembly may now be removed from the transmitter.

**CAUTION**

Care must be exercised not to damage the cam follower arm of S101. This arm is attached to the left side of the oscillator casting.

**Note**

All components not included in units that may not be removed from the main assembly of the transmitter have been mounted in positions so as to be as accessible as possible in the limited space available. The cabinet cover, bottom plate and Autotune cover plate are all removable from the main assembly. The location of the part to be checked or replaced will determine the section of the cabinet that is to be removed.

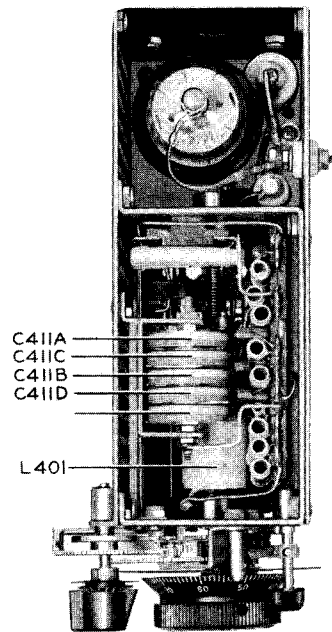

Figure 5-4. Type O-16/ART-13 Low Frequency Oscillator

**5. RADIO-FREQUENCY CIRCUIT ALIGNMENT.**

a. TYPE O-16/ART-13 LF OSCILLATOR ALIGNMENT. (Refer to figure 5-4. and figure 5-5.)

(1) If low-frequency oscillator circuit components have been damaged or replaced, the grid circuit may require realignment. For realignment of the circuit the following procedure should be followed:

(a) Operate Control "F" to Position 6 (1035 kc to 1500 kc).

(b) Rotate the CHANNEL selector switch, S108, the L. FREQ. position.

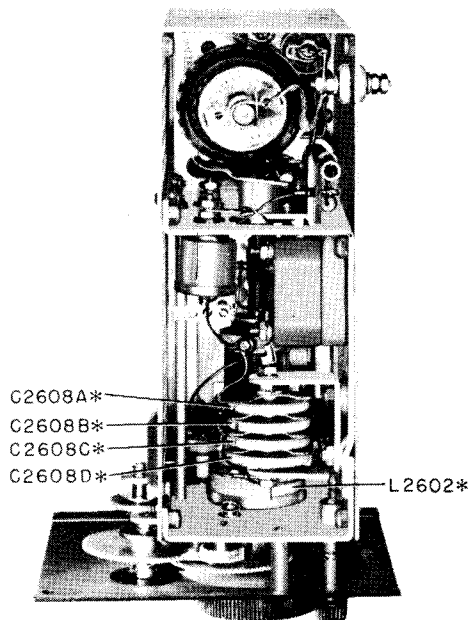

**Figure 5-4A. Type O-17/ART-13A Low Frequency Oscillator**

(c) Operate the EMISSION selector switch, S110, to the VOICE position.

(d) When the Autotune cycle has been completed check the position of Control "A".

The control should stop in position 13. If the control stops in any position other than number 13, loosen the locking bar and manually operate Control "A" to position 13.

(e) Refer to TABLE 3-1. in Section III of this book and select a dial setting under column G that is near the middle of the tuning range. If there is a dial setting listed on each side of the midpoint of the tuning range, select the dial setting on the high-frequency side. For example, 1016 in the column under G is very near midpoint of the tuning range of the control. (The exact midpoint is 1000.)

(f) Rotate Control "G" to the dial setting that has been chosen from the calibration table.

(g) Operate the power level switch, S106, to the CALIBRATE position. (Applies 1150 volts dc to plate of V104.)

(h) Insert an earphone cord plug into the SIDETONE output jack, J104.

(i) While listening to the SIDETONE amplifier output, rotate Control "G" about the setting obtained from the calibration table until exact zero beat is obtained between the output of the low-frequency oscillator and the output of the calibration oscillator.

(j) Check the dial setting and lock the dial.

(k) Loosen the two set screws that hold the knob to the shaft of Control "G" and without detuning the circuit, rotate the knob on the shaft

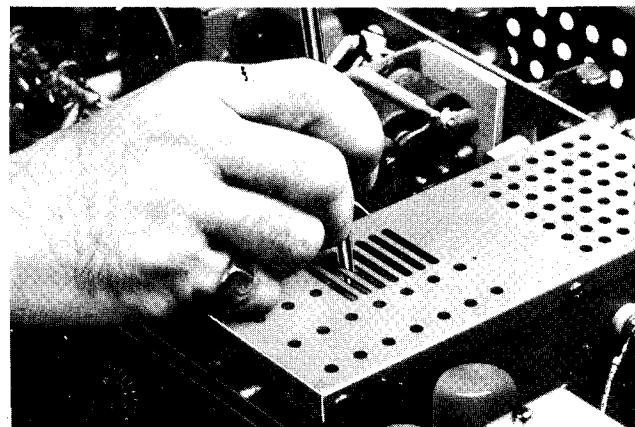

**Figure 5-5. Low Frequency Oscillator Unit Adjustment**

until the dial setting corresponds to the setting given in the calibration table and tighten the set screws.

(l) Rotate Control "G" to home stop position near zero. Loosen the two set screws on the counter dial mechanism collar attached to the main oscillator shaft and holding the mechanism at zero, rotate Control "G" to zero. Tighten the set screw.

(m) Operate Control "F" to position 5.

(n) As explained in steps (e) and (f), select a dial setting from TABLE 3-1. near the middle of the tuning range.

(o) Note the numbered slots on the oscillator shield cover exposing the trimming capacitor, C411.

(p) While listening to the SIDETONE output, adjust capacitor section E (5) of C411 with any narrow tool until zero beat is obtained between the low-frequency oscillator output and the output of the calibration oscillator.

(q) Operate Control "F" to position 4 and repeat steps (m) and (o) adjusting section D (4) of C411 instead of section E.

(r) Repeat steps (m) and (o) adjusting capacitor trimmer sections C (3), B (2) and A (1), for Control "F" positions 3, 2 and 1, respectively.

(s) Check the excitation over the entire range of each position of Control "F" by rotating Control "G" through twenty revolutions for each position of Control "F".

**b. TYPE 0-17/ART-13A LF OSCILLATOR ALIGNMENT. (Refer to figure 5-4A.)**

(1) If for any reason this oscillator shall require realignment, the following procedure shall be used:

(a) Operate control "F" to position 3 (415 Kc to 600 Kc).

(b) Rotate CHANNEL selector switch,



S108, to the L. FREQ. position.

(c) Operate EMISSION selector switch, S110, to the VOICE position.

(d) When the Autotune cycle has been completed, check the position of control "A". The control should stop in position 13. If the control stops in any position other than number 13, loosen the locking bar and manually operate control "A" to position 13.

(e) Remove cover on top of L.F.O. unit by taking out screws around rim.

(f) Turn control "G" counterclockwise until revolution counter dial reads zero and control "G" will not turn any further. Operate corrector knob so that index line is directly above the center of control "G" even though it no longer points to zero line on the control.

(g) Measure the length of tuning slug that extends out of the rear end of inductor L2602\*. This dimension should be 3/16". If the slug extends out by this amount, no change in slug position is required and the following steps (h), (i) and (j) may be omitted, proceed with step (k). If the slug is incorrectly set, proceed with step (h).

(h) Examine dial drive mechanism and note small spur gear on same shaft that passes through panel from control knob "G". Loosen two Bristo setscrews that hold this spur gear to main shaft.

(i) Hold gear train in dial drive mechanism, so that it cannot rotate. Then rotate control "G" until slug in inductor L2602\* extends 3/16" out of the coil form.

(j) Retighten Bristo setscrews in small spur gear.

(k) Loosen two setscrews in control knob "G" and holding the gear train stationary, set knob so that zero mark lines up with the index line. Then retighten set screws in the knob.

(l) Set control "G" to read exactly 1964.0 (this is dial setting shown in Table 3-1A for frequency of 600 kc). Approach setting in a clockwise direction.

(m) Replace shield cover on top of low frequency oscillator unit. Operate power level switch to CALIBRATE position.

(n) Connect headphones to sidetone output jack.

### WARNING

Dynamotor is now operating and there is 1150 volts on caps at tops of tubes V104, V-105 and V-106. Extreme caution should be exercised to avoid contact with points during remainder of alignment procedure.

(o) While listening to sidetone output, adjust trimmer condenser C2608A\* (see figure 5-4A, and note that trimmer can be reached through slot in shield cover of LFO unit), until zero beat is obtained with the output of the calibration oscillator in the CFI unit. These trimmer condensers are adjusted by changing the position of the small "pronged" metal lip that projects out from the side of the rounded edge of the capacitor. Using an insulated tool, merely push the lip to change the capacity of the condenser.

(p) The alignment of band 3 is now complete. Rotate control "F" to band 2 (285 to 415 Kc).

(q) Set control "G" to read exactly 1055.0 (this is dial setting shown in Table 3-1A for frequency 350 Kc). Approach setting in a clockwise direction.

(r) While listening to sidetone output (in head phones), adjust capacitor C2608B\* (see figure 5-4A) until "zero beat" is obtained between output of low frequency oscillator and calibration oscillator in CFI unit.

(s) The alignment of band 2 is now complete. Rotate control "F" to band 1 (200 to 285 Kc).

(t) Set control "G" to read exactly 1216.8 (this is dial setting shown in Table 3-1A for frequency of 250 Kc). Approach setting in a clockwise direction.

(u) Listen to sidetone output and obtain "zero beat" by adjusting either or both trimmer capacitors C2608C\* and C2608D\* (see figure 5-4A).

(v) Alignment of band 1 is now complete. Check excitation over entire range on all three bands by rotating control "G" through 20 revolutions and observing P.A. GRID reading. The excitation should be nearly uniform over entire frequency range and P.A. GRID meter should read between 90 and 120.

### c. HIGH-FREQUENCY OSCILLATOR ALIGNMENT USING CFI. (Refer to figure 5-6. and figure 5-7.)

(1) If the high-frequency RF circuits are to be realigned in the field, where no frequency measuring equipment is available, the calibration oscillator may be used to check the band end-point frequencies. However, if coils, transformer cores, capacitors, etc., in the oscillator circuit require replacement, an accurate means of measuring frequency must be used together with a portable frequency meter to check the harmonic output of the frequency multiplier.

(2) For realignment when a frequency stand-

ard is not available, the following procedure should be followed:

(a) With the EMISSION selector switch, S110, in the OFF position, remove the cover plate from the right-hand end of the transmitter cabinet. Remove the small plate on the bottom of the oscillator casting. This plate covers the holes provided for the adjustment of trimmer capacitors C134 and C135. The HF oscillator grid trimmer capacitors, C134 and C135, the HF oscillator grid inductor, L101, tuning slug adjustment and the frequency multiplier plate inductor, L105 and L106, tuning slug adjustments are thus exposed.

(b) Rotate the CHANNEL selector switch, S108, to the MANUAL position.

(c) Operate the EMISSION selector switch, S110 to the VOICE position.

(d) When the Autotune cycle has been completed, operate Control "A" to Position 2.

(e) Set the indicator mark, over Control "B", to mid-scale using the CORRECTOR knob.

(f) Refer to TABLE 3-2. in Section III of this book and obtain the dial setting of Control "B" for output on 2400 kc with Control "A" in Position 2. (Oscillator output on 1200 kc.)

(g) Rotate Control "B" to the setting obtained from the table. Approach the setting in a clockwise direction.

(h) Loosen the nut on the rear of the lead screw that holds the multiplier tuning slug yoke to the screw.

(i) Insert an earphones cord plug into the SIDETONE output jack, J104.

(j) Operate the power level switch, S106, to the CALIBRATE position. (Applies 1150 volts dc to plate of V104.)

(k) While listening to the SIDETONE output in the earphones, and keeping Control "B" set at the position obtained from the table, adjust the position of the HF oscillator grid inductor tuning slug by rotating the tuning slug screw with pliers, the jaws of which are padded to prevent marring the shaft, until zero beat is obtained between the output of the calibration oscillator and the output of the high-frequency oscillator.

**Note**

Caution should be exercised in the adjustment of the position of the tuning slug when no frequency standard is available. A fraction of a revolution in one direction or the other should realign the circuit.

(l) When zero beat has been obtained, carefully tighten the nut on the end of the slug screw to prevent further displacement of tuning slug.

(m) Refer to TABLE 3-2. in Section III and obtain the correct position of Control "B" for output on 3000 kc with Control "A" in position 2. (Oscillator output on 1500 kc.)

(n) Rotate Control "B" to the setting obtained from the table. Approach the setting in a clockwise direction.

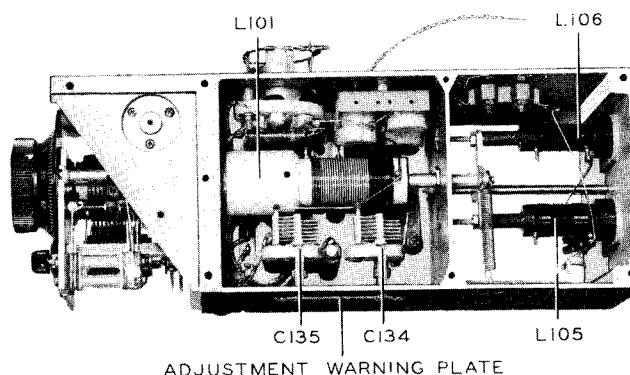

**Figure 5-6. High Frequency Oscillator**

(o) Adjust trimming capacitor C134, (figure 5-6. and figure 5-7.) until zero beat is obtained between the output of the HF oscillator and the output of the calibration oscillator.

(p) Check several points in the band by obtaining Control "B" settings from TABLE 3-2. and listening to the beat note output of the SIDETONE amplifier.

(q) If the setting of Control "B" necessary to obtain exact zero beat deviates more than 4 or 5 dial divisions from the setting given in the calibration table, repeat steps (f) through (p) of the above procedure until the dial settings necessary to obtain a given frequency correspond very closely to those given in the calibration table.

(r) When alignment adjustments have been completed with Control "A" in position 2, operate the control to position 1.

(s) Refer to TABLE 3-2. opposite 2000 kc (Control "A" in position 1) and obtain the dial setting for Control "B". (Oscillator output on 1000 kc.)

(t) While listening to the SIDETONE output, adjust trimming capacitor C135 (figure 5-7.) until zero beat between the high-frequency oscillator output and the calibration oscillator output is obtained.

**Note**

Do not make any further adjustments of trimmer C134.

(u) Check several points within the frequency range 2000 kc to 2400 kc by obtaining the dial setting of Control "B" from the table, listening to the SIDETONE output and operating Control "B" about the setting obtained from the calibration table. The settings should check with those given in the table within 4 or 5 dial divisions.

**Note**

No adjustment of the high-frequency oscillator grid inductor slug should be made with Control "A" in position 1,

(v) Return the EMISSION selector switch, S110, to the OFF position.

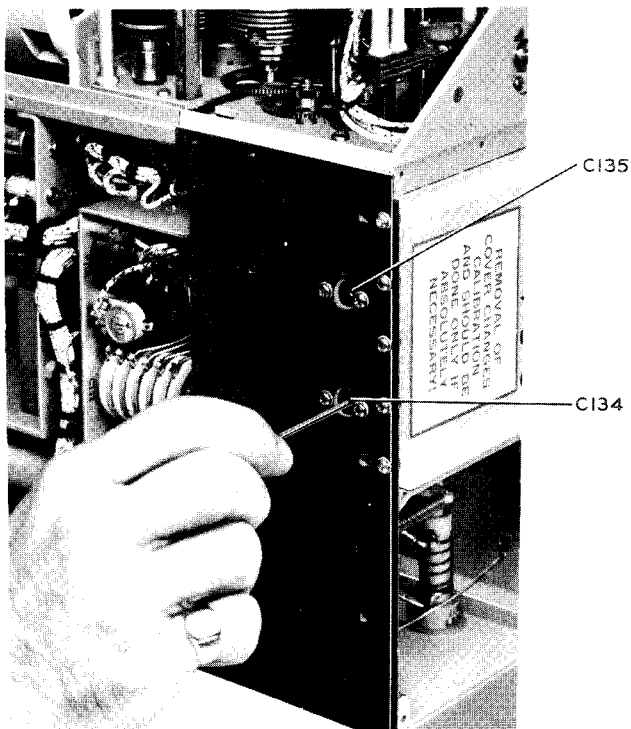

Figure 5-7. High Frequency Oscillator Adjustment

d. HIGH-FREQUENCY OSCILLATOR  
ALIGNMENT USING EXTERNAL  
FREQUENCY STANDARD.

(Navy Type LM or Army Type SCR-211)

(1) If oscillator circuit components have been

replaced and an accurate frequency standard is available the following procedure should be followed for the alignment of the high-frequency oscillator circuit:

(a) With the EMISSION selector switch, S110, in the OFF position remove the cover plates from the right-hand end and bottom of the transmitter cabinet. The HF oscillator grid trimmer capacitors, C134 and C135, the HF oscillator grid inductor, L101, tuning slug adjustment and the frequency multiplier plate inductor, L105 and L106, tuning slug adjustments are exposed.

(b) Rotate the CHANNEL selector switch, S108, to the MANUAL position.

(c) Operate the EMISSION selector switch, S110, to the VOICE position.

(d) When the Autotune cycle has been completed, operate Control "A" to position 2.

(e) Set the indicator mark, over Control "B", to mid-scale using the CORRECTOR knob.

(f) Refer to TABLE 3-2. and obtain the dial setting for an output frequency of 2400 kc with Control "A" in position 2. (Oscillator output on 1200 kc.)

(g) Rotate Control "B" to the setting obtained from the table.

(h) Loosen the nut on the rear of the lead screw that holds the multiplier tuning slug yoke to the screw.

(i) Operate the power level switch, S106, to the CALIBRATE position. (Applies 1150 volts dc to plate of V104.)

(j) Measure the output frequency of the oscillator and adjust the position of the tuning slug in 101 until the oscillator frequency is exactly 1200 kc.

(k) When the correct position of the tuning slug has been found tighten the locking nut to prevent any further displacement of the slug.

(l) Refer to TABLE 3-2. and obtain the setting of Control "B" necessary to obtain an output frequency of 3000 kc with Control "A" in position 2. (Oscillator output on 1500 kc.)

(m) Rotate Control "B" to the setting obtained from the table.

(n) Measure the output frequency of the oscillator and adjust capacitor trimmer C134 (figure 5-7.) until the frequency of the oscillator output is exactly 1500 kc.

(o) Check several points within the band by obtaining dial settings from the calibration

tables, rotating Control "B" to these settings and measuring the frequencies.

**Note**

Always keep in mind that with Control "A" in positions 1 or 2 the frequencies given in the calibration tables are always twice the output frequency of the oscillator. With the power level switch in the CALIBRATE position only the oscillator is operating, therefore, the output frequency to be measured will always be one-half the frequency that is given in the calibration tables.

(p) If the dial settings of Control "B" necessary to obtain output on a selected frequency deviates more than 4 or 5 dial divisions from the dial setting given in the calibration tables repeat steps (f) through (o) until the actual dial setting of control "B" necessary to obtain a given output frequency corresponds very closely to the setting given in the table.

(q) When alignment has been completed with Control "A" in position 2, operate the control to position 1.

(r) Refer to TABLE 3-2. and obtain the dial setting of Control "B" to obtain an output frequency of 2000 kc with Control "A" in position 1. (Oscillator output on 1000 kc.)

(s) Adjust trimming capacitor C135 (figure 5-7.) until the oscillator output frequency is exactly 1200 kc.

**Note**

Do not make any adjustments of C134 or the core in inductor L101 with Control "A" in position 1.

(t) Check several points within the band by comparing the actual dial settings necessary to obtain a given frequency with the dial settings given in the calibration tables for the same frequency. The settings should check within 4 or 5 dial divisions.

(u) Return the EMISSION selector switch, S110, to the OFF position.

e. FREQUENCY MULTIPLIER ALIGNMENT. (Refer to figure 5-8. and figure 5-9.)

(1) Having completed the alignment of the high-frequency oscillator circuit complete the R-F circuit alignment by following the procedure outlined below for the adjustment of the frequency multiplier circuits:

(a) With the transmitter tipped up on the rear edge and the bottom cover removed, the frequency multiplier plate tank capacitors are exposed.

**Note**

The multiplier plate tank capacitors are located beneath the multiplier chassis. (Stacks of ceramic capacitor sections.) Capacitor section A of each capacitor, C111 and C115, is located nearest the right-hand side of the transmitter, as the transmitter is viewed from the bottom, with sections B, C, D, E, and F in order in the stack.

(b) Operate Control "A" to position 6.

(c) Rotate the metered circuit selector switch, S105, to the P.A. GRID position.

(d) Rotate Control "B" until the dial deading is 1100.

(e) Operate the power level switch to the TUNE position.

(f) Operate the EMISSION selector switch, S110 to the CW position. (Applies 1150 volts dc plate potential.)

**CAUTION**

Use an insulated tool to adjust the capacitors. When the key is operated the capacitor is at a potential of 400 volts above ground.

(g) Insert a shorted plug in KEY jack J103 and adjust section F (bottom of stack) of first multiplier padding capacitor C111 to the position that will give the maximum P.A. GRID meter reading on M102.

**Note**

To vary the capacity of sections of C111 or C115 rotate the metal lip that protrudes between capacitor sections.

(h) Using a portable frequency meter check the output frequency of the first frequency multiplier stage to be sure that the plate circuit is tuned to the correct harmonic. The output should be on approximately 5400 kc with Control "A" in position 6 and Control "B" tuned to a dial reading of 1100.

(i) When it has been ascertained that the multiplier output is on the correct harmonic rotate Control "B" over the entire range, and observe the grid reading on meter M102.

**CAUTION**

When the key is operated the inductors L105 and L106 are at a potential of 400 volts above ground.

(j) Take out dips in the meter reading by adjusting section F of first multiplier padding capacitor C111 for an average reading of the meter.

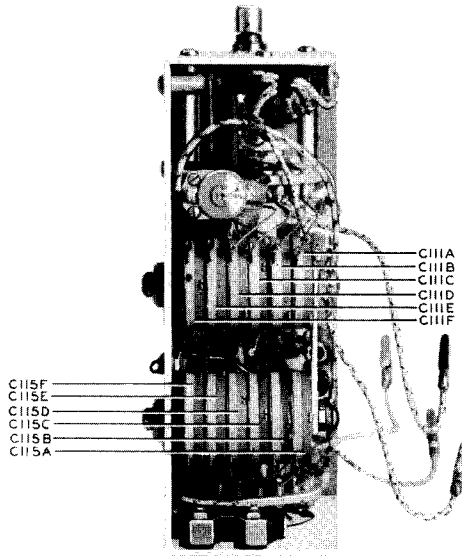

Figure 5-8. Frequency Multiplier

**CAUTION**

When the key is operated the inductors L105 and L106 are at a potential of 400 volts above ground.

(k) A drop at the extreme ends of the range is permissible but if the meter needle still dips sharply at any other point, rotate Control "B" to a dial reading of 1100, loosen the first multiplier inductance L105 tuning slug locking nut and change slightly the position of the tuning slug. Tighten the slug locking nut.

(l) Rotate Control "B" over the entire range and check the P.A. GRID current. Meter M102 should indicate a consistent value of grid current over the entire range. If the meter needle dips sharply at any point repeat steps (j) and (k).

(m) Having completed the adjustment of the inductor slug and section F of C111, remove the key shorting plug and rotate Control "A" to position 5.

(n) Rotate Control "B" to a dial reading of 1100.

(o) Replace the key shorting plug, adjust section E of capacitor C111 to give a maximum P.A. GRID meter reading and check with a frequency meter for the correct harmonic.

**Note**

Do not make any further adjustments of the position of the tuning slug in L105.

(p) Rotate Control "B" through the entire range and check the excitation. If dips occur in the meter reading readjust padding capacitor C111E.

(q) Remove the key shorting plug and operate Control "A" to position 4.

(r) Replace the key shorting plug and adjust section D of C111 for maximum P.A. GRID meter reading.

(s) Check the excitation over the band by operating Control "B" over the entire range. If dips in the meter reading occur repeat step (j).

(t) Repeat steps (r) and (s) for positions 4, 3, 2, and 1 of Control "A". Adjust capacitor sections D, C, B, and A for Control "A" positions 4, 3, 2, and 1 respectively.

(u) Having completed the alignment of the 1st frequency multiplier stage, remove the key shorting plug and operate Control "A" to position 12.

(v) Rotate Control "B" to a dial reading of 1100.

(w) Replace the key shorting plug and adjust section F of second multiplier padding capacitor C115 for maximum P.A. GRID meter reading.

(x) Using an insulated screwdriver to reduce body capacity adjust trimmer capacitor C136 for maximum P.A. GRID meter reading.

(y) Check the output frequency of the second multiplier with a frequency meter. With Control "A" in position 12 and Control "B" tuned to a dial reading of 1100 the frequency meter should indicate approximately 16,430 kc. A materially different reading indicates that a wrong harmonic has been chosen necessitating a readjustment of padding capacitor C115F and trimmer capacitor C136.

(z) Take out dips in the meter reading by adjusting section F of padding capacitor C115.

(aa) A drop at the extreme ends of the range is permissible but if the meter needle still dips sharply at any other point, rotate Control "B"

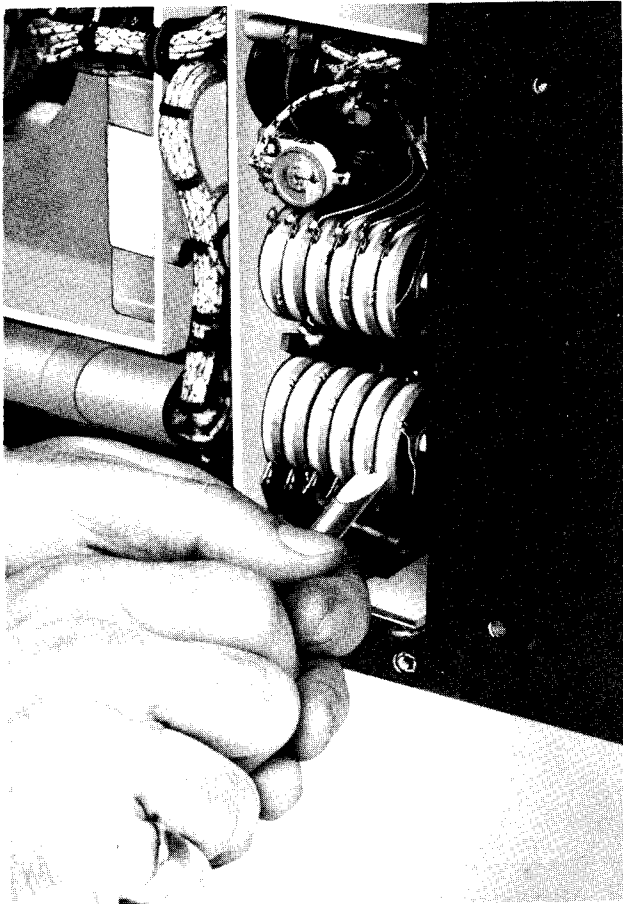

Figure 5-9. Frequency Multiplier Adjustment

to a dial reading of 1100, loosen the second multiplier inductance L106 tuning slug locking nut and change the position of the tuning slug slightly. Tighten the slug locking nut.

(bb) Again rotate Control "B" over the entire range and check the excitation. If the meter dips sharply at any point repeat steps (x) through (bb).

(cc) Having completed the adjustment of the inductor slug and section F of C115, remove the key shorting plug and rotate Control "A" to position 11.

(dd) Rotate Control "B" to a dial reading of 1100.

(ee) Replace the key shorting plug, adjust section E of capacitor C115 to the capacity which gives the maximum P.A. GRID meter reading and check with a frequency meter for the correct harmonic.

**Note**

Do not make any further adjustment of the tuning slug in L106 or trimmer capacitor C136.

(ff) Rotate Control "B" through the entire range and check the excitation. If dips occur in the meter reading readjust padding capacitor C115E.

(gg) Repeat steps (ee) and (ff) with Control "A" in positions 10, 9, 8, and 7. Adjust capacitor sections D, C, B, and A for Control "A" positions 10, 9, 8, and 7 respectively.

The above procedure completes the alignment of the high-frequency RF circuits of the transmitter.

**6. MCW-CFI ADJUSTMENT.**

**Note**

If at any time erratic or abnormal operation is observed, or the unit fails to function entirely, the tubes and crystal should be carefully checked. Tube failure is probably the most common cause of the failure of any electronic device. The most dependable method of checking and finding the defective tube or crystal is to replace each tube one at a time with tubes known to be in good condition and to insert another crystal known to be active and correct in frequency.

**IMPORTANT**

Realignment or servicing other than tube or crystal replacement should not be attempted until the tubes and crystal have been carefully checked and unless the alignment procedure of the unit is thoroughly understood.

**WARNING**

Because the inductor tuning adjustment screws are in a difficult position to reach when the unit is in place in the transmitter, and because of the proximity of exposed leads carrying potentials of more than 400 volts, a short extension cable allowing the MCW-CFI Unit to be on the bench beside the transmitter is recommended. A cable for this purpose is included in the bulk spares.

**Note**

Because of the small space, adjustment of the unit is most conveniently made with a very small "jewelers" type screwdriver having a shank at least 1¼ inches long. Such a screwdriver is included in the bulk spares.

**a. CFI ALIGNMENT USING TRANSMITTER SIDETONE CIRCUITS.**

(1) Make sure that EMISSION selector switch S110 is in the OFF position.

(2) Insert a coin or a screwdriver in the slot of the transmitter cover hold-down screws, rotate the screws one-half revolution counterclockwise and lift off the cover.

(3) Loosen the two large screws that hold the unit to the main transmitter chassis.

(4) Raise the unit until the connector plug is disengaged and lift the unit out.

(5) Connect an extension cable to MCW-CFI jack J111 in the transmitter and to unit plug P2201.

(6) Turn LOCAL-REMOTE switch S107 to the LOCAL position.

(7) Connect earphones to the sidetone circuits by inserting the earphones cord plug into SIDETONE jack J104.

(8) Rotate CHANNEL selector switch S108 to the MANUAL position.

(9) Turn EMISSION selector switch S110 to the VOICE position.

(10) When the Autotune cycle has been completed, rotate Control "C" to any dial reading, taking care to approach the chosen setting clockwise through at least one-eighth turn and to set the dial accurately.

(11) Rotate Control "A" to position 1.

(12) Turn power level switch S106 to the CALIBRATE position. (Applies 1150 volts dc to plate of V104.)

(13) Adjust SIDETONE gain control switch S202 to position 2 and search for calibration beat signals by rotating Control "B".

(14) If beat signals are not found, insert a small screwdriver in the slot of inductor Z2201A tuning adjustment screw, adjacent to which is stamped the number "200". Rotate this screw, while continuing to rotate Control "B", until a beat signal is heard, indicating operation of the crystal oscillator. Refer to figure 5-10.

(15) If a loud squeaking rush noise appears as soon as the crystal oscillator functions, adjust inductor Z2202A tuning adjustment screw, adjacent to which is stamped the number "150", until this noise disappears. Absence of such noises is one indication of correct unit operation.

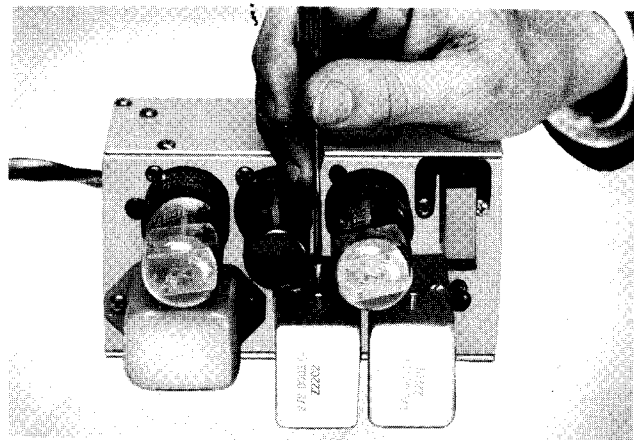

**Figure 5-10. MCW-CFI Unit Adjustment**

(16) Vary the pitch of the beat signal arrived at, by adjusting Control "B", to a pitch easy to listen to. Adjust SIDETONE gain control switch S202 to a position giving comfortable volume level.

(17) Adjust inductor Z2201A tuning adjustment screw for the mid-point of the maximum volume range.

(18) Tune the HF oscillator by rotating Control "B" until two loud signals of approximately equal volume are heard.

(19) Compare the zero beat signal dial settings of the two selected beat points with the calibration table check points to determine if the interval between the points is 100 kc (oscillator frequency is doubled on range 1 causing 50 kc interval with oscillator to be recorded as 100 kc).

(20) If the interval is correct and the dial readings correspond reasonably (within 25 dial divisions) with the calibration table tune Z2201B (farthest from crystal) marked "50", tune Z2202B (nearest crystal) marked "50", and tune Z2202A (marked "150") for maximum sidetone output. Recheck tuning in the same order.

(21) Turn the transmitter on and off several times, noting whether the crystal oscillates positively as soon as the transmitter is turned on. Detune Z2201A (marked "200") slightly to improve crystal starting if necessary.

(22) If less than a 50 kc interval (recorded 100 kc on Band 1) is obtained, rotate mixer tank Z2202B adjustment screw clockwise three turns, then rotate tripler tank Z2202A adjustment screw counterclockwise until harsh noises occur and disappear. Repeat Steps 18 to 20 inclusive.

(23) If more than a 50 kc interval (recorded 100 kc on Band 1) is obtained, rotate mixer tank Z2202B adjustment screw counterclockwise three turns, then rotate tripler tank Z2202A adjustment screw clockwise until harsh noises occur and disappear. Repeat Steps 18 to 20 inclusive.

(24) The unit can now be considered to be aligned and the calibration frequency accurate to within very close limits. Replacement in the transmitter completes the operation.

**Note**

It is possible for the unit to be adjusted in the transmitter by removing the multiplier tubes, since the 400 volt plate potential is removed from the multiplier tube plate cap leads by the operation of power level switch S106 to the CALIBRATE position. However, in the interests of safety, this procedure is not recommended, since the exposed plate cap lead of the HF oscillator and the exposed LF oscillator plate lead terminals are at a potential of more than 400 volts above ground.

b. MCW ADJUSTMENT. — The frequency of the audio tone oscillator is fixed at approximately 1000 cps but the output level may be varied by means of a variable resistor R2201. To adjust the audio tone oscillator output level follow the procedure outlined in Steps (1) to (5) inclusive in the section devoted to CFI adjustment preparations and then proceed as follows:

(1) Adjust the transmitter for MCW operation on any frequency and place it in operation.

(2) By means of an oscilloscope or other modulation level measuring device measure the percentage of modulation.

(3) Insert a screwdriver through the hole provided in the back side of the MCW-CFI Unit and engage the exposed slot. (See figure 6-28, page 6-43.)

(4) Rotate the screwdriver until the desired percentage of modulation is attained. An adjustment providing 70% modulation at full power will provide approximately 100% modulation at half power (power level relay K2105 operated).

c. CFI ALIGNMENT USING VACUUM TUBE VOLTMETERS.—If multi-scale reversible polarity DC vacuum tube voltmeters are available, the following alignment procedure should be followed. Although it is possible to follow this procedure using only one such meter, it is recommended that

wherever possible three meters be employed as described.

(1) Follow steps 1 to 8 inclusive in the preceding adjustment procedure.

(2) Connect the normally negative or grounded lead of meter No. 1 to a ground in the unit. Connect the normally positive or above ground lead through a 1 megohm resistor to terminal No. 4 of X2201 (V2201 oscillator control grid). Adjust meter to read 0 to -30 volts.

(3) Connect and adjust meter No. 2 in the same manner as in step (2) except to select terminal No. 1 of X2201 (V2201 tripler control grid).

(4) Connect meter No. 3 in the same manner as in step (2) except to select terminal number 8 of X2202 (V2202 mixer control grid). Adjust meter to read 0 to -10 volts.

(5) Follow steps (9) to (12) inclusive outlined in the preceding adjustment procedure.

(6) Insert a small screwdriver in the slot of inductor Z2201A tuning adjustment screw, adjacent to which is stamped the number "200". Rotate this screw for maximum voltage as indicated on meter No. 1 (step (2) ).

(7) Rotate inductor Z2202A, tuning adjustment screw, adjacent to which is stamped the number "150" until maximum negative voltage is indicated on meter number 2. (Several voltage peaks may be found, possibly even a positive one. The correct position of the adjustment screw is that which gives the highest negative meter reading.)

(8) Rotate inductor Z2202B tuning adjustment screw adjacent to which is stamped the number "50" (nearest crystal) until the maximum voltage peak is indicated on meter number 3.

(9) Repeat steps (7) and (8) until meter number 2 and meter number 3 indicates maximum reading simultaneously.

(10) Turn power level switch S106 to the TUNE position.

(11) Disconnect meters and reconnect a meter to terminal number 1 of X2203 (detector section of V2203 control grid).

(12) Adjust SIDETONE gain control switch S202 to position 2 and turn power level switch S106 to the CALIBRATE position. (Applies 1150 volts dc to plate of V104.)

(13) Using headphones, adjust Control "B" until a beat signal is heard on a HFO frequency ending in 50 (consult calibration tables in data section). Vary the pitch of the beat signal ar-



rived at, by adjusting Control "B", to a pitch easy to listen to. Adjust SIDETONE gain control switch S202 to a position giving comfortable volume level.

(14) Rotate inductor Z2201A tuning adjustment screw, adjacent to which is stamped the number "50" (farthest from crystal) until the meter indicates minimum voltage. The beat note heard in the headphones varies in volume as this point is approached. The adjustment screw should be adjusted in the vicinity of minimum voltage meter reading at the point which produces a maximum audio level beat note located between two weaker points.

### 7. PRECISION CALIBRATION OF MCW-CFI UNIT CRYSTAL OSCILLATOR.

a. The 200 kc crystal used in the MCW-CFI Unit is accurate to within  $\pm 0.01\%$  0-70°C (32-158°F). Variations in the tuning of the crystal tank circuit through the range in which the crystal will stay in oscillation averages about 25 cycles off crystal frequency. It can be seen therefore that the CFI can be considered accurate for all practical purposes.

b. The alignment procedure previously outlined presupposes a T-47/ART-13 transmitter oscillator in good working condition and reference to the oscillator calibration table for determining the 50 kc interval CFI output.

c. The remote possibility of obtaining other than a 50 kc interval during alignment can be checked by listening on a nearby calibrated receiver, especially if the receiver is provided with a beat frequency oscillator, and observing that a 50 kc interval exists between harmonics of the CFI output as the receiver is tuned over a range of about 300 kc. For this purpose, a well shielded receiver should be used. Proceed as follows in making this check:

(1) Obtain a length of stranded, insulated wire about 6 feet long. Connect one end of the wire to the antenna terminal on the receiver and the other end to the ground terminal on the receiver. Twist the two leads together and make a loop in the extreme end of the "twisted-pair."

(2) Place the loop over the detector and audio oscillator tube V2203 which is located farthest from the crystal unit in the MCW-CFI Unit.

(3) Place transmitter LOCAL - REMOTE switch S107 in the LOCAL position.

(4) Place EMISSION selector switch S110 in the VOICE position.

(5) Operate power level switch S106 to the CALIBRATE position. (Applies 1150 volts dc to plate of V104.)

(6) Place the receiver in operation and turn on the receiver beat frequency oscillator.

(7) Listen to the receiver as it is tuned over a range of about 300 kc and observe whether a 50 kc interval exists between the beat notes observed. If other than a 50 kc interval is observed, refer to the CFI alignment procedure outlined in paragraph 7.,c. step (1) to (8) inclusive and step (22) or (23).

(8) Again tune the receiver repeating the procedure outlined until the interval is correctly 50 kc.

d. Since a slight variation in the output frequency of the crystal oscillator is possible by detuning the crystal oscillator tank circuit, this factor can be used to adjust the CFI output frequency to exact zero beat with another highly accurate frequency standard by feeding the output of such a standard into the receiver while it is connected in the manner described in paragraph 9.,c. except that the receiver beat frequency oscillator must be turned off. Any such standard to be of value must be constantly checked against the U.S. Bureau of Standards or similar transmissions. If such a transmission can be received directly, the ultimate in accurate adjustment of CFI frequency can be obtained by attaching an antenna to the receiver, in addition to the "twisted-pair" connection to the receiver, and obtaining a zero beat between the standard transmission and the CFI output. Any standard used in the manner outlined must be a multiple of 50 kc.

### 8. MAINTENANCE OF AUTOTUNE MECHANISM.

#### a. LUBRICATION.

(1) The four types of lubricants required are: (1) Texaco Capella A lubricating oil manufactured by the Texas Company, 135 E. 42nd St., New York City, (2) Socony-Vacuum PD-535A lubricating grease manufactured by the Socony Vacuum Oil Co., 26 Broadway, NYC, and (3) Cities Service North Star 000 oil manufactured by The Cities Service Oil Co., 500 Roberts St., Saint Paul, Minn. Replaceable AUTOTUNE lubrication wicks (see Table of Replaceable Parts, Section VII) are obtainable from Collins Radio Co., Cedar Rapids, Iowa. In locations where severe dust is encountered, it may be necessary to thoroughly clean all parts before application of any lubricants. A soft brush and a jet of compressed air will be suitable for cleaning the Autotune mechanism.

AN 08-30ART13-5

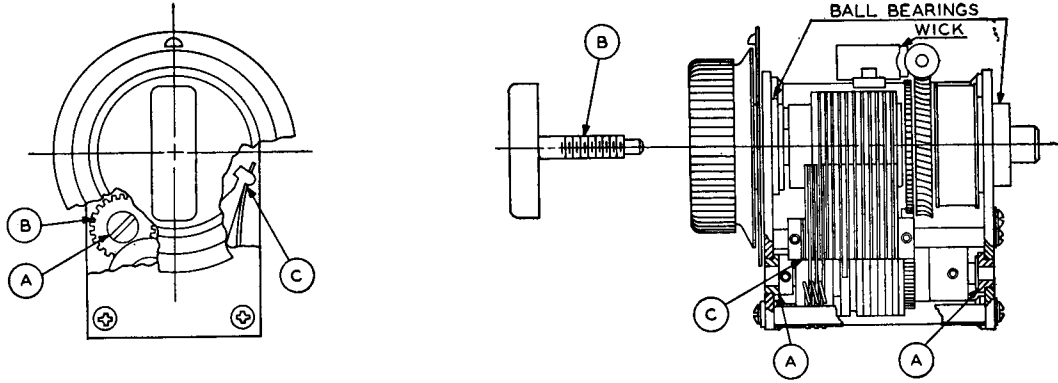

SINGLETURN UNIT

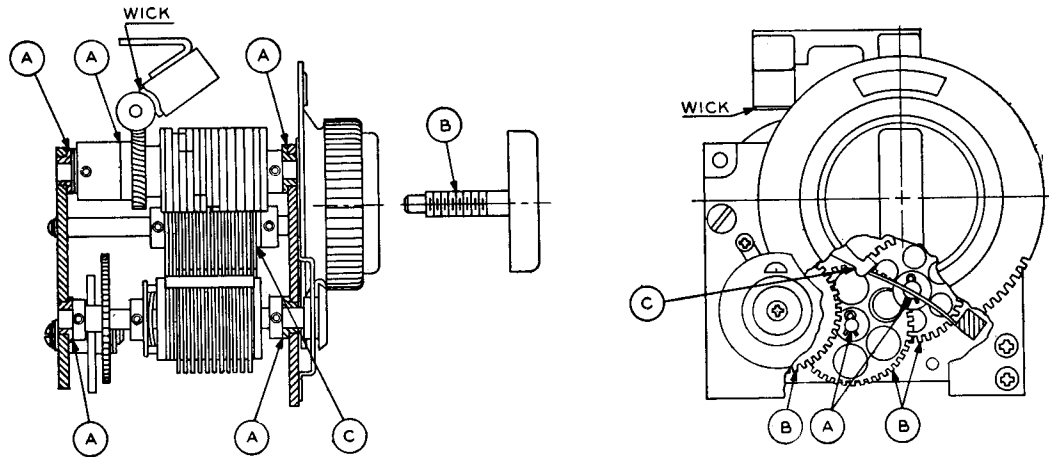

MULTITURN UNIT

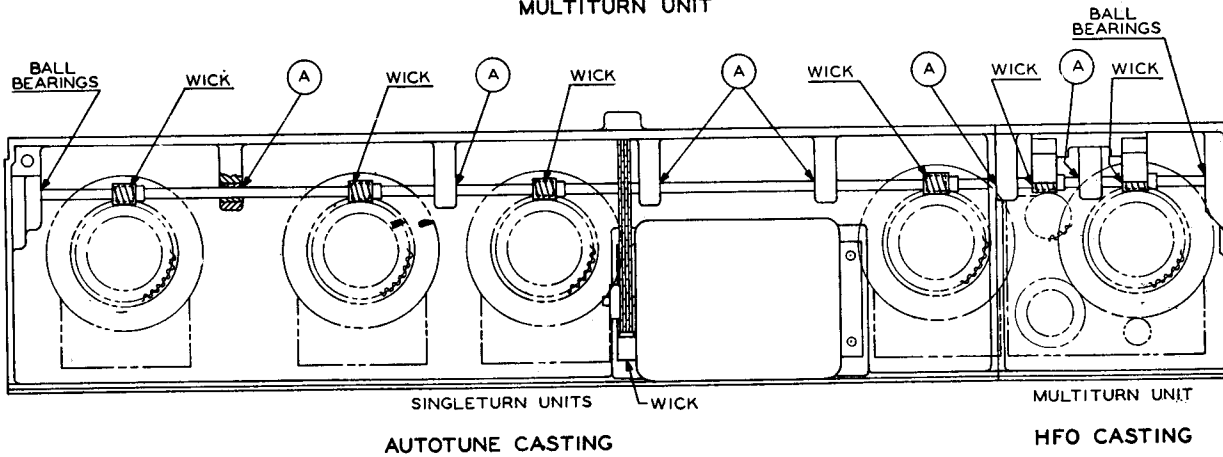

SINGLETURN UNITS  
AUTOTUNE CASTING

MULTITURN UNIT  
HFO CASTING

**SEMI-ANNUALLY**

EACH ARROW INDICATES A POINT OF LUBRICATION. LETTERS WITHIN BALLOONS CORRESPOND TO LUBRICANTS LISTED BELOW. APPLY SPARINGLY WITH CAMEL HAIR BRUSH. REMOVE EXCESS LUBRICANT.

- (A) TEXACO CAPELLA A OIL (OR EQUAL)
- (B) SOCONY VACUUM PD5 35A GREASE (OR EQUAL)
- (C) CITIES SERVICE NORTH STAR 000 (OR EQUAL)

BALL BEARINGS SHOWN ABOVE DO NOT REQUIRE LUBRICATION.

**ANNUALLY**

REPLACE 7 WICKS WITH A COMPLETE NEW SET. DO NOT RE-USE WICKS.

**Figure 5-11. Autotune System Lubrication Chart**

(2) The Texaco Capella A oil is to be used for all lubrication points except the open gears and pawls. The points to be lubricated with this oil include:

- (a) All line shaft bearings.
- (b) Autotune motor bearings.
- (c) Front and rear cam drum bearings on each of the Autotune units.
- (d) All idler gear bearings.
- (e) Counter drum bearings.
- (f) Limit switch driver shaft bearings.

(3) The Socony-Vacuum PD-535A grease should be used on all gears. These gears include:

- (a) Spur and idler gears on all Autotune units.
- (b) The screw on the limit switch drive shaft.

(4) Cities Service North Star 000 oil should be used for lubricating the pawl stacks on each of the Autotune units.

(5) Replaceable wick lubricators are used in the following positions:

- (a) All line shaft worms.
- (b) Autotune chain drive.

(6) The Autotune Lubrication Chart, figure 5-11., shows the proper points for the application of each type of lubricant. The letters inside the circles denote the type of lubricant to be used at each point. The letters A, B, and C, are identified with the lubricants they represent at the bottom of figure 5-11.

(7) Each of the three lubricants may be applied with a camel's hair brush to the various lubrications points. Only very small amounts of oil or grease are required at most points. Be sure to remove any excess oil or grease after lubricating the Autotune system.

(8) It will not be necessary to remove the individual Autotune units in order to lubricate the mechanism properly. The transmitter should be turned on the back and the Autotune front panel removed for maximum access to the lubrication points.

(9) The wick lubricator on the singleturn Autotune units can be most easily replaced by loosening the screws clamping the wick holder to the unit and sliding the holder forward. The wick lubrication holders on the multiturn Autotune unit and the Autotune chain drive must be removed in order to replace the wicks.

#### b. SYNCHRONIZATION CHECK.

(1) In order for the Autotune system to function properly, the five individual units must be carefully synchronized. If there is any reason to doubt the accuracy of the synchronization, it should be immediately checked. This may be done as follows:

(2) Turn the equipment on the back so as to have maximum access to the units and remove the Autotune front panel.

#### Note

If the counter drum rings in the multi-turn unit "B" have been moved for any reason so that a pawl cannot fall in the slot of a given ring within the range of the counter drum rotation, the ring must be moved manually a quarter turn in either direction.

(3) Place the crank (which is included in the spare parts) on the right end of the Autotune line shaft, orient the crank hub in the slot and fasten it with a 4-40 x 1/2" screw.

(4) By means of the crank turn the line shaft counterclockwise until all the cam drums are being driven. Continue to turn the crank counterclockwise until the stop-ring drum on the Multi-turn unit has reached home stop and has ceased to turn.

(5) After the stop-ring drum on the Multi-turn unit has ceased to turn and only the cam drums are turning, pull the fork of the anvil (*figure 5-14,*) in a counterclockwise direction away from under the tails of the pawls so that they are free to fall to the surface of the counter drum. If at any time the line shaft should be turned clockwise, it will first be necessary to turn the line shaft again in the counterclockwise direction far enough to reach home stop before pulling the anvil out from under the tails of the pawls; otherwise, as soon as the line shaft is turned counterclockwise, the anvil will be rotated up under the tails of the pawls.

(6) Continue to rotate the crank slowly until the number 5 pawl on one of the units, just drops into its cam slot.

#### Note

Count from the front of the Autotune unit to the back, omitting the first or manual pawl, to arrive at pawl number 5.

(7) Note the position of the crank arm by marking a line on the casting and then slowly turn the crank, noting the points at which the No. 5

pawls on all of the other units drop into the cam slots. All of the pawls should drop into place within a quarter turn ahead or behind the point where the No. 5 pawl or unit "A" engaged with its cam. All pawls should drop sharply with a "click."

(8) Continue to rotate the crank counterclockwise until the No. 6 pawl on one of the units, just drops into its cam slot.

(9) Note the position of the crank arm by marking a line on the casting and then slowly turn the crank, noting the points at which the No. 6 pawls on all of the other units drop into the cam slots and repeat the procedure outlined in Step (7).

(10) Repeat Steps (8) and (9) checking the operation in turn of pawls No. 7, 8, 9, 10, 11, 12 (Low Frequency), manual, 1, 2, 3, and 4.

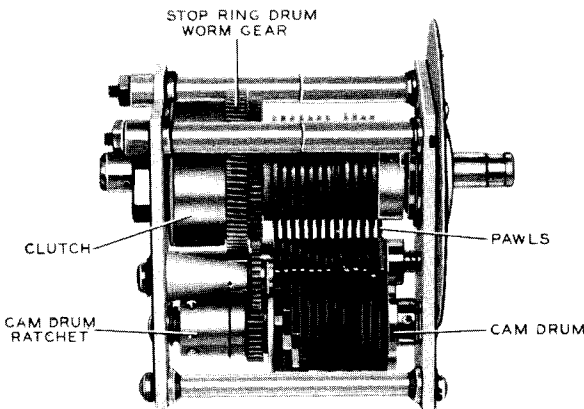

Figure 5-12. Autotune Singleturn Unit—Left Side

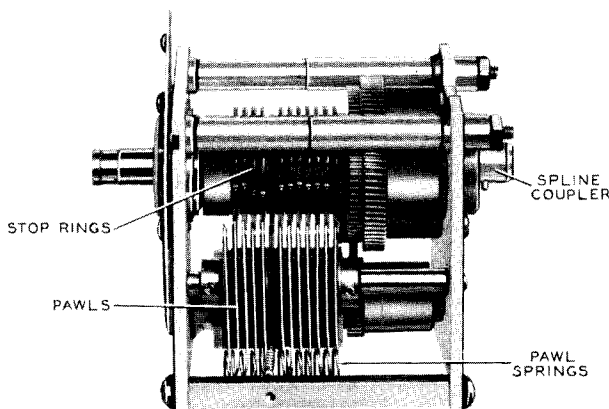

Figure 5-13. Autotune Singleturn Unit—Right Side

c. SYNCHRONIZATION.

(1) If the Autotune system is found to be out of synchronism, the following procedure should be used to restore it:

(2) Determine the units that are not in synchronism with the multiturn unit by use of the

foregoing procedure. No adjustment is possible on the multiturn unit, therefore all other units should be synchronized with this unit. Refer to figures 5-12., 5-13., 5-14. and 5-15.

(3) Repeat the procedure outlined in paragraph b.,(4) and (5).

(4) If it has been found by means of the Synchronization Check that Autotune unit "A" is not synchronized with Autotune unit "B", it may be synchronized as follows:

(a) Turn the line shaft counterclockwise until pawl No. 5 on unit "B" just drops into its slot in the cam drum. At this point the cam drum on unit "A" should be in a position so that the set screws on the collar below the gear are accessible. In case one of the set screws is inaccessible, tighten the accessible set screw with a number 6 Bristo wrench and continue to turn the line shaft counterclockwise until the inaccessible set screw can be reached and loosened with the number 6 Bristo wrench, after which it will be necessary to continue to turn the line shaft in a counterclockwise direction until pawl number 5 on unit "B" again just drops into its slot in the cam drum. When this point is reached the remaining set screw in the collar on the cam drum shaft in unit "A" should be loosened. In case the above conditions cannot be met, it will be necessary to choose some other pawl that will allow these conditions.

(b) The cam drum in unit "A" is now free to be turned with the fingers until No. 5 pawl just drops into its slot in the cam drum.

(c) Insert a 0.005 inch feeler gauge between the cam drum washer, which is adjacent to the cam drum and the gear on the cam drum shaft in unit "A". Now insert a number 6 wrench in the accessible set screw, force the collar tight against the gear and around clockwise so that all play is taken up before tightening the screw. Care must be used not to move the cam drum during this step.

(d) Turn the line shaft counterclockwise noting the sequence in which the pawls on unit "A" fall with respect to the corresponding pawls on unit "B". If all the corresponding pawls on the two units fall within one-quarter turn of the line shaft, the two units are synchronized. The second set screw in the collar on unit "A" cam drum shaft should now be tightened.

(5) It is entirely possible, due to slight irregularities in the structure of the cam drums, that one or more corresponding pairs of pawls on the two units will not fall within the prescribed one-

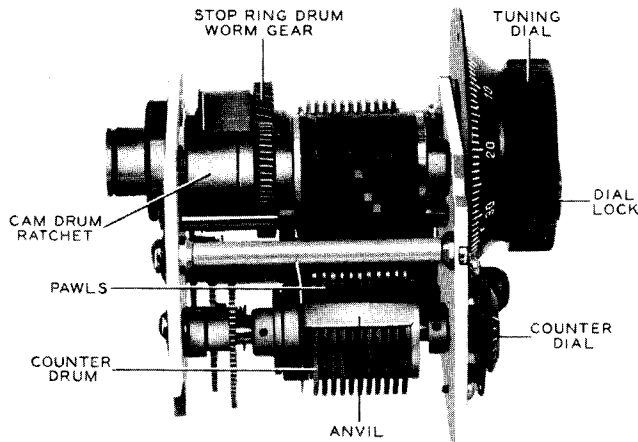

Figure 5-14. Autotune Multiturn Unit—Left Side

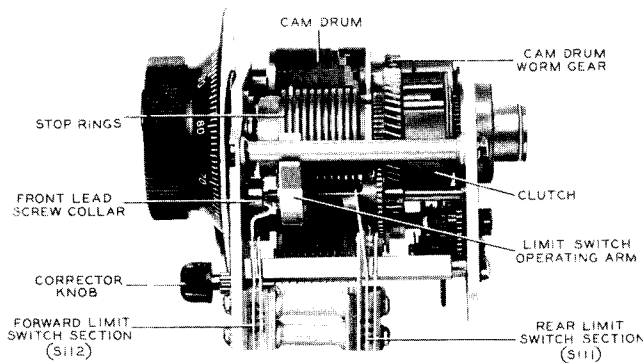

Figure 5-15. Autotune Multiturn Unit—Right Side

quarter turn tolerance or that the synchronizing was not done with sufficient care, causing even No. 5 pawl on unit "A" to drop ahead or behind No. 5 pawl on unit "B" by more than one-quarter turn.

(a) If it is found necessary to correct the synchronization, turn the line shaft counterclockwise noting the sequence in which the pawls fall. If some or all of the corresponding pawls fall farther apart from each other than the prescribed tolerance, pick out the pair that drops farthest apart and note which pawl drops first.

(b) If the pawl on unit "A" drops first, note what part of a revolution the line shaft must be turned through before the corresponding pawl on unit "B" falls. Continue to crank the line shaft counterclockwise until the two set screws on the collar below the cam drum on unit "A" are easily accessible. After loosening the set screws, turn the line shaft counterclockwise through the required part of a turn deemed necessary to correct the error and tighten the set screws. Repeat with more care if the pawls upon rechecking do not yet fall within the prescribed limits.

(c) If the pawl on unit "B" drops first, note what part of a revolution the line shaft must be turned through before the corresponding pawl on unit "A" falls. Continue to crank the line shaft counterclockwise until the two set screws on the collar below the cam drum on unit "A" are easily accessible. After loosening the set screws, rest the hand on the frame of unit "A" and, placing the thumb firmly on the cam drum, rotate the cam drum slightly counterclockwise by the amount judged necessary to correct the error, then tighten the set screws. Repeat with more care if the pawls upon rechecking do not yet fall within the prescribed limits.

(d) Check to make sure that both set screws in the collar on unit "A" cam drum shaft are tight.

(6) If it has been found by means of the Synchronization Check that Autotune unit "D", "C", or "E" is not synchronized with unit "A", causing corresponding pawls on units "A", "D", "C" and "E" to drop more than one-quarter turn of the line shaft apart, it will be necessary to re-synchronize the unit or units with unit "A" which are not within the one-quarter turn tolerance by the same procedure given for synchronizing unit "A" with unit "B" as outlined in Steps (4) and (5).

(7) It should be noted that when the Autotune System has been synchronized correctly, corresponding pawls on units "A", and "B" drop within one-quarter turn of each other and the corresponding pawls on units "C", "D" and "E" drop within one-quarter turn of those on unit "A".

#### d. AUTOTUNE POSITIONING MECHANISM.

(1) The Autotune positioning control mechanism consists of the Autotune seeking switch, S109, which is of the open segment type, driven by an arm attached to the shaft of the cam drum on the singleturn Autotune unit "A", and the CHANNEL selector switch, S108.

(2) The seeking switch driving arm must be so adjusted that when, for instance, position number 5 is selected by the CHANNEL selector switch S108, the number 5 pawl will drop on all Autotune units and be in this position at the end of the Autotune cycle. In addition, the driving arm pin must engage the driven arm completely, but the pin must not touch the frame of the seeking switch, S109, at any point of the 360 degree rotation. Finally, a "back-up" distance of roughly  $\frac{5}{64}$  inch  $\pm \frac{1}{64}$  must be maintained between the pin of the driving arm and its place of contact on

the driven arm after the cam drum, to which the driving arm is attached, is rotated by hand clockwise as far as it will go.

(3) If there is reason to believe that the seeking switch driving arm is out of adjustment, the following procedure should be followed to check it:

(a) Turn the CHANNEL selector switch, S108, to any position.

(b) Turn the EMISSION selector switch, S110, to the VOICE position. If the Autotune motor starts running allow it to run until the Autotune cycle is complete and the motor stops.

**Note**

If the motor continues to run more than 30 seconds without coming to a stop, observe whether, due to misalignment of the seeking switch driving arm, the seeking switch, S109, is not being driven before turning the EMISSION selector switch, S110, to the OFF position. If the adjustment of the seeking switch driving arm appears to be correct, the trouble is probably misalignment of or foreign matter in the motor control relay, K101 or limit switch, S111 and S112. A short in the seeking switch itself can cause this trouble as can a short in the wiring.

(c) Turn the EMISSION selector switch, S110, to the OFF position.

(d) Connect a continuity indicator from the number 1 contact of remote cable jack J106 to the GND connector on the transmitter. Operate the LOCAL-REMOTE switch, S107, to the REMOTE position.

(e) Repeat the procedure outlined in paragraphs 10.,b.,(2) to 10.,b.,(4) inclusive.

(f) Continue to rotate the crank slowly until the last pawl corresponding to the contact selected has just dropped into its cam slot.

(g) Note the position of the crank arm by marking a line on the casting and then slowly turn the crank until the continuity is broken.

(h) Observe the fraction of a revolution that the crank has turned. It should be within the limits of one-eighth to one full turn of the crank.

(i) If the continuity is not broken within the limits of one-eighth to one full turn of the crank, the seeking switch driving arm must be adjusted.

(j) Repeat Steps (f), (g), and (h) for

each contact of remote cable jack J106 up to and including No. 11.

(4) If it is determined in checking by the procedure outlined in paragraph 10.,c.,(3) that the driving arm of the seeking switch, S109, is out of adjustment, it may be readjusted as follows:

(a) If the switch shaft is not centered exactly with the cam drum shaft in front of it or if the mounting screws are loose, correct these conditions by recentering the switch shaft and tightening the screws.

(b) Select a position by turning the line shaft crank counterclockwise that will place the set screws in the hub of the seeking switch driving arm in an accessible position.

(c) Loosen the set screws with a number 6 Bristo wrench.

(d) Turn the seeking switch driving arm clockwise if the switch as checked in Step (3) opened early, and counterclockwise if it opened late. The amount to turn the arm must be determined by trial and error, but will be very slight unless it has become loose enough to cause an entirely different pawl number to drop on the Autotune units.

(e) Tighten the set screws, taking care that the pin completely engages the driven arm but does not come so close to the frame of the seeking switch as to permit it to touch at any point of the 360 degree rotation.

(f) Recheck as outlined in Steps (3), (f), (g), (h) and repeat procedure until the Autotune seeking switch, S109, is correctly adjusted.

**e. AUTOTUNE LIMIT SWITCH.**

(1) The limit switch is composed of a front section, S112, and a rear section, S111, and is located on the right side of the Multiturn or "B" Autotune unit. Refer to figure 5-15.

(2) The rear limit switch section, S111, should be adjusted so that it snaps between the limits of  $3\frac{1}{4}$  to  $9\frac{1}{4}$  turns of the line shaft crank counting clockwise from the time the switch snaps until the collar pin on the switch operating arm is engaged by the rear lead screw collar.

(3) Add or remove shims from the rear end of the front switch section, S112, insulator stack until the foregoing conditions can be met.

**Note**

Do not attempt to bend the arms of the rear switch sections as such a procedure may destroy the snap action of the switch.

(4) The front limit switch section should be adjusted so that it closes between the limits of  $3\frac{1}{4}$  to  $9\frac{1}{4}$  turns of the line shaft crank in a clockwise direction from the reference point. This reference point is arrived at by turning the line shaft crank counterclockwise until the collar pin on the switch operating arm is engaged by the front lead screw collar. A continuity indicator connected across the switch contacts will facilitate noting the exact moment the switch makes the contact.

(5) The main arm of the front switch section should follow the short arm for slightly less than  $\frac{1}{32}$  inch as the short arm is bent back until contact is broken. This assures adequate contact pressure necessary for reliable operation of the switch.

(6) Using an ordinary telephone relay spring bender, bend the head of the long switch contact arm and the heel end of the short contact leaf until the foregoing conditions [Steps (4) and (4)] are met.

(7) Make sure that the leaves of the front and rear switch sections are in the clear and are not in danger of shorting on any part of the mechanism.

#### 9. REPLACEMENT OF AUTOTUNE PARTS.

a. The following Autotune parts may be replaced in the field if adequate shop facilities are available. Since the Autotune mechanism is necessarily complicated, it is recommended that only skilled and experienced personnel be permitted to repair it.

#### REPLACEABLE AUTOTUNE PARTS

<u>Item</u>	<u>Quan.</u>	<u>Part Description</u>	<u>Used with Item*</u>	<u>Collins Part No.</u>
1	1	Multiturn Autotune Unit "B"		520 0361 40 or 96K-1
2	1	Includes wick Lubricator Singleturn Autotune Unit "A"		500 4644 001 571 0738 30 or 96J-4
3	1	Includes Wick Lubricator Singleturn Autotune Unit "C"		500 4630 001 572 0737 30 or 96J-2
4	1	Includes Wick Lubricator Singleturn Autotune Unit "D"		500 4630 001 571 0737 30 or 96J-1
5	1	Includes Wick Lubricator Singleturn Autotune Unit "E"		500 4630 001 573 0737 30 or 96J-3
6	1	Includes Wick Lubricator Dial for Unit A	2	500 4630 001 508 1069 20 or NY-1069B
7	1	Dial for Unit B	1	507 5524 00 or X-5524
8	1	Dial for Unit C	3	508 1072 20 or NY-1072B
9	1	Dial for Unit D	4	507 5586 00 or NX-5586
10	1	Dial for Unit E	5	507 5796 00 or NX-5796
11	5	Dial Locking Bar	6, 7, 8, 9, 10	507 5525 00 or NX-5525
12	5	Bar Stop Disc	11	507 5620 00 or X-5620
13	1	Main Line Shaft	17	507 5512 00 or NX-5512
14	4	Singleturn Worm	13	507 5513 00 or NX-5513

<u>Item</u>	<u>Quan.</u>	<u>Part Description</u>	<u>Used with Item*</u>	<u>Collins Part No.</u>
15	1	Small Multiturn Worm	17	Same as (14)
16	1	Large Multiturn Worm	17	507 5519 00 or NX-5519
17	1	Multiturn Line Shaft	13	507 5517 00 or NX-5517
18	1	Main Line Shaft Thrust Bearing	13	309 1320 00 or 309N132
19	1	Multiturn Line Shaft Thrust Bearing	17	309 1360 00 or 309N136
20	6	Line Shaft Bearing	13, 17	507 5724 00 or NX-5724
21	1	Line Shaft Crank	17	571 1149 10 or GA-1149A
22	1	Counter Drum Dial	1	507 5527 00 or X-5527
23	1	Positioning Switch Drive Arm	2	571 0881 10 or 881A
24	1	Chain Drive	13, 25, 26	507 5603 00 or NX-5603
		Includes Wick Lubricator		500 4635 001
25	1	Motor Sprocket	24	507 5602 00 or NX-5602
26	1	Line Shaft Sprocket	13, 25, 26	507 5514 00 or NX-5514

\* Numbers appearing in this column refer to the item numbers listed in the first column of this table.

**b. REMOVING COMPONENT PARTS.**

(1) Cover—remove 16 screws and lift off. (Cover must be removed before any other units or parts are removed.)

(2) Motor—remove 3 mounting screws and unsolder four wires to motor. Pivot motor as it is lifted out so as to free it from chain drive.

(3) Autotune unit "A"—turn dial locking bar to unlock position and loosen the two #10 Bristo set screws in the dial. Turn dial and locking bar counterclockwise together until bar comes free. Remove both dial and locking bar. Remove the dial back plate, loosen the two long screws on the top end of the unit and the short screw on the bottom end of the unit. Lift the unit out.

(4) Autotune unit "C", "D", or "E"—remove 4 screws, one on each of Autotune units "C", "D", and "E" and one on the end of the jack strip. Pull the strip out as far as the wires will permit. Turn locking screw on Autotune unit "C", "D", or "E" to unlock position and loosen the two #10 Bristo set screws in the dial. Remove dial, remove dial back plate, loosen the two long screws on the top

end of the unit and the short screw on the bottom of the rear plate. Lift the unit out.

**Note**

Autotune units "C", "D", and "E" differ only in that the clutches are designed to exert a different torque on each of these units. Each unit is stamped at the bottom of the front plate with the control letter "C", "D" or "E". Care must be exercised not to interchange these units. Note that the control dials are not interchangeable because of the dial engraving.

(5) Autotune unit "B"—remove the right end cover plate and the dial and back plate from unit "A". Next remove the #10 nut on the back end of the main tuning slug leadscrew which is attached to the multiplier slug coupling yoke. Then remove the two mounting screws along the upper edge of the backplate of the multiturn unit; also remove the single screw along the lower edge. Remove the two screws which hold the limit switch and carefully pull the switch away from the assembly. Pull the assembly out of the casting care-



fully so as not to damage the tuning slug on the leadscrew.

**Note**

If the leadscrew is turned even slightly the high frequency oscillator must be recalibrated and realigned.

(6) Line Shaft—remove all Autotune singleturn units and four screws of the thrust bearing on left end of shaft. Remove taper groove pins on worms for heads A, C, and D and on sprocket. Pull shaft assembly out of the left end of Autotune casting.

**CAUTION**

Be very careful not to spring the line shaft when driving out the taper groove pins. Support the shaft adjacent to the gears when removing or replacing the taper groove pins. Keep the gears separate and in order so each may be replaced in the same location from which it was removed.

(7) Replacing control dials "A", "B", "C", "D" and "E"—Care must be exercised to replace the dials exactly as they were before disassembly. Each dial must clear the dial back plate throughout the range of the Autotune unit to which it is attached.

(a) Dial "A" should indicate range No. 1 when the contact arm of range switch S102 is centered on contact No. 1. The setting must be approached clockwise from the counterclockwise rotation limit.

(b) Dial "B" should indicate "O" when the multiturn unit is at the counterclockwise home stop position when the reference marker is in a vertical position.

(c) Dial "C" should read between 1 and 13 when the unit is rotated against the counterclockwise rotation limit. Rotating the dial to position No. 1 should cause a tooth of the star cam to seat squarely on the roller of Autotune interlock switch S113D during the interval that the contact arm of S113C rests squarely on contact No. 1. Contact No. 1 is located farthest from the transmitter front panel.

(d) Dial "D" should indicate "O" when the crosswise half-turn in the rotor winding of variometer L112 is at the top of the unit and the windings of the unit are in alignment. This setting must be approached clockwise from the counterclockwise limit of rotation.

(e) Dial "E" should be adjusted so that switch S113A is completely closed when the dial reads 100 and completely open when the dial reads 200. The switch must operate in the blank space between the dial readings of 100 and 200.

**c. SERVICING THE MAIN LINE SHAFT ASSEMBLY.**

(1) The following replaceable parts are associated with the main line shaft assembly:

Item	Description
13	Main Line Shaft
14	Singleturn Worm (4)
18	Main Line Shaft Thrust Bearing
20	Line Shaft Bearing (4)
24	Chain Drive
25	Line Shaft Sprocket

(2) In order to replace these parts it will be necessary to remove the entire line shaft assembly. Care must be exercised to keep each gear in the proper order when disassembling the line shaft. None of the gears are interchangeable. Refer to figure 5-16.

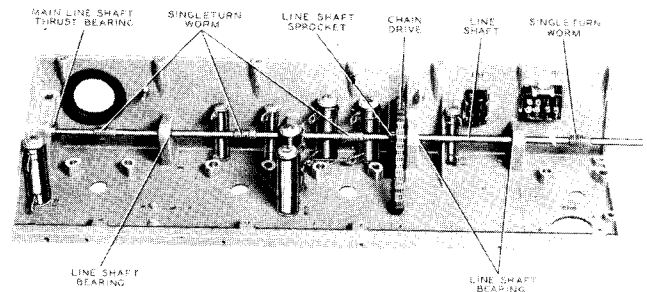

**Figure 5-16. Autotune Casting**

(3) The following procedure is recommended for removing the line shaft assembly.

**CAUTION**

When driving out the taper groove pins be very careful not to spring the line shaft.

(a) Remove all singleturn Autotune heads (heads A, C, D, and E).

(b) Remove the taper groove pin from each of the worms and the sprocket. Before driving out a taper groove pin, be sure that the line shaft is well supported adjacent to the taper groove pin.

(c) Remove the four screws from the thrust bearing retainer plate on the left end of the casting.

(d) Slowly work the shaft off the left end of the casting removing each worm or the sprocket as it nears the end of the shaft. Be sure each

gear is properly identified so as to be replaced in its original position. These gears are not interchangeable because each gear is drilled while on the line shaft.

*d. REPLACING A SINGLETURN WORM.*—The replacement singleturn worm is furnished undrilled. The following procedure is recommended for replacing a singleturn worm:

(1) Center-punch the sleeve of the worm in the spot corresponding to the center of the hole on the old worm.

(2) Using a  $\frac{1}{16}$  inch drill, drill through one side of the worm sleeve.

(3) Slide the worm on the shaft with the sleeve end away from the thrust bearing assembly.

(4) Drill through to the other side of the worm sleeve with the  $\frac{1}{16}$  inch drill.

(5) Proceed to reassemble the line shaft in the reverse order of the foregoing disassembling procedure using new  $\frac{1}{16} \times \frac{3}{8}$  inch taper groove pins on the worms and a new  $\frac{5}{64} \times \frac{1}{2}$  inch taper groove pin on the sprocket.

*e. REPLACING A LINE SHAFT SPROCKET.*—Follow the same procedure as used for replacing the singleturn worm except use a number 47 drill.

*f. REPLACING THE CHAIN DRIVE.*—As the line shaft is being pulled out the left end of the casting, slip off the old chain and sprocket. Put the new chain on the sprocket and push the line shaft back into place, slipping the shaft through the sprocket. Slip the singleturn worm on the end of the shaft and then replace with new taper groove pins.

*g. REPLACING A LINE SHAFT BEARING.*—The oilite type line shaft bearings are held in place by means of a press fit. A thin steel sleeve fits over these bearings. After removing the line shaft the defective bearing should be driven out gently by using a mallet and a rod or blunt end punch. The new bearing then should be gently driven into place. Be careful not to deform the bearing.

*h. REPLACING THE MAIN LINE SHAFT THRUST BEARING.*—In replacing this bearing, it will not be necessary to remove the entire line shaft assembly. The following procedure is recommended:

(1) Remove the four screws from the bearing retainer plate on the left end of the casting.

(2) Remove the taper groove pin from the line shaft sprocket.

(3) Work the shaft end bearing out about an inch or more from the end of the casting.

(4) Carefully block up the outside bearing collar and drive out the taper groove pin from the inside bearing collar.

**CAUTION**

Be careful not to spring the line shaft when driving the taper groove pin out.

(5) Replace the inside collar on the shaft, slide the new bearing on the shaft and then slide the outside collar through the bearing into the inside collar.

(6) Insert a taper groove pin and gently drive it home.

**CAUTION**

Be sure the outside collar is blocked up properly so that the line shaft will not be sprung.

(7) Slide the shaft back to its original position and replace the bearing plate. Use a new taper groove pin in the line shaft sprocket.

*i. REPLACING THE MAIN LINE SHAFT.*—The task of installing a new line shaft is difficult and lengthy and should only be attempted by an experienced mechanic who has adequate tools available. The following procedure is recommended for replacing the main line shaft:

(1) Remove the line shaft as previously prescribed.

(2) Reassemble the gears on the shaft and drive the taper groove pins in lightly.

(3) Carefully measure the distance from the milled end of the shaft to one end of each worm, the sprocket and the thrust bearing.

(4) Completely disassemble the line shaft.

(5) Centerpunch each gear and the sprocket at a point which is at a right angle to the previously used taper groove pin hole and the same distance from the end.

(6) Drill each gear with a  $\frac{1}{16}$  inch drill and the sprocket with a number 47 drill through on one side only.

(7) Put one of the worms on the shaft, in its predetermined position, block the shaft well, and, using a  $\frac{1}{16}$  inch drill, drill through the new hole in the gear into the line shaft through the other side of the gear.

(8) Suitably mark the new hole on the sleeve of the gear.

(9) Repeat steps (7) and (8) for the remain-

ing worms and sprocket. Use a number 47 drill for the sprocket.

(10) Assemble the bearing and slide it on the end of the shaft.

(11) Clamp the bearing, block the shaft and drill through the two sleeves and the shaft at a point at right angles to the old hole. Use a  $\frac{1}{16}$  inch drill.

(12) Suitably mark the new hole on both sleeves.

(13) Using new taper groove pins (five  $\frac{1}{16}$  x  $\frac{3}{8}$  inch and one  $\frac{5}{64}$  x  $\frac{1}{2}$  inch) assemble the shaft in the casting as previously described.

#### Note

Be sure to place the gears in their proper order on the shaft.

#### j. SERVICING THE MULTITURN LINE SHAFT ASSEMBLY.

(1) The following replaceable parts are associated with the Multiturn line shaft assembly:

<u>Item</u>	<u>Description</u>
15	Small Multiturn Worm
16	Large Multiturn Worm
17	Multiturn Line Shaft
19	Multiturn Line Shaft Thrust Bearing
20	Line Shaft Bearing

(2) This shaft assembly may be serviced in the same general way as the main line shaft. The multiturn head must be removed before any work may be done on the shaft. The large worm requires a  $\frac{5}{64}$  x  $\frac{1}{2}$  inch taper groove pin and the small worm and thrust bearing require  $\frac{1}{16}$  x  $\frac{3}{8}$  inch taper groove pins.

#### 10. THE ADJUSTMENT AND THE REPLACEMENT OF PARTS OF COMMERCIAL ASSEMBLIES.

##### a. GENERAL.

(1) The following drawings and parts lists cover standard commercial assemblies for which replacement parts are obtainable. Ordering information is given such as to permit identification of any part which is subject to failure as a result of normal wear in service.

(2) Because of special design the manufacturers of the pressure operated relay, K2106, and the Autotune motor control relay, K101, consider it impractical to replace parts of these assemblies. If any of these units fail, a complete assembly should be ordered.

(3) Adjustment data on the following assemblies is included:

<u>Part Number</u>	<u>Function</u>
405 0009 00 (K101) (Alternate 405 2201 10)	Autotune Motor Control Relay
410 0008 00 (K102) (Alternate 410 0011 00)	Keying Relay
410 1700 00 (K103)	CW Emission Control Relay
410 1600 00 (K104)	Voice Emission Control Relay
410 0010 00 (K105)	Output Circuit Selecting Relay
401 7900 00 (K2101)	Dynamotor Input Control Relay
405 2202 00 (K2102)	Primary Power Contactor
410 2000 00 (K2105)	Power Change Relay
260 4570 00 (K2106)	Pressure Operated Relay
274 1400 00 (S603)	Telegraph Key

##### b. GENERAL REQUIREMENTS FOR SATISFACTORY OPERATION.

(1) All screws and nuts should be tight.  
(2) All relay assemblies should be securely mounted.

(3) When replacing parts such as coils or contacts, the wires should have a little slack, but not enough to interfere with moving parts. All unnecessary solder should be removed and bare wire should be bent in such a manner that it will not touch adjacent metal parts.

(4) When replacing armatures or contacts, the bushings and springs should be carefully aligned and checked for free operation.

(5) When adjusting contact springs, the bends in the springs should be gradual rather than sharp bends or kinks.

(6) Contacts should be carefully aligned and under no condition should the contacts be more than one-fourth of the diameter of the contacts out of alignment with respect to each other as gauged by eye.

(7) The coils should measure within  $\pm 5\%$  of the specified dc resistance.

#### Note

The resistance values of the windings are based upon a normal temperature of 20 degrees C (68 degrees F). If the resistance is measured at a temperature other than 20 degrees C (68 degrees F) corrections should be made for the difference in temperature.

(8) It is important that the relay contacts be kept free from corrosion and pits. The relays should be inspected regularly and if the contacts have become corroded a burnishing tool should be used to remove the corrosion.

(9) The armature should not make contact with the core.

c. RELAY ADJUSTMENT.

(1) 405 2201 00 (Alternate) (K101)

The contact should be adjusted so that when the relay is in the unoperated position the spacing between the movable contact and the stationary contact is between .040 inch and .050 inch. The armature should be adjusted so that the spacing between the armature and the top edge of the field pole is .040 inch. The tension of the armature spring should be adjusted so that the armature back tension is 7 ounces. This relay should operate with a minimum of 18 volts dc and a maximum of 32 volts dc. The dc resistance of the coil, measured at 20°C (68 degrees F.), should be 150 ohms.

(2) 410 0008 00 (K102)

This relay has been provided with three adjusting screws. Refer to figure 5-18. The two adjusting screws located on the side of the relay opposite the multiterminal connector plug control the position and tension of the relay armature when the relay is unoperated. The lower adjusting screw, item 5, determines the position of the armature and the upper screw, item 4, determines the tension of the armature return spring. The tension of the armature return spring, as measured at the top of the bakelite strip should be between 23 ounces and 24 ounces.

To set the armature position, leave the relay in the unoperated condition and rotate the lower adjusting screw in a clockwise direction until the movable contacts just begin to lift from the fixed contacts. Then rotate the adjusting screw approximately one-half revolution in a counterclockwise direction. The movable contacts should rest firmly against the fixed contacts. The position of each fixed contact is adjustable and may be set by loosening the locking nut and rotating the contact. Contacts are numbered according to the terminal number of the plug to which they are connected. The contacts operate in the following sequence when the coil is energized: Group number one, 1 and 11 open, 2 and 12 open, 5 and 4 (or 3 and 5) open, and vacuum contact (S116) opens. Group number two, vacuum contact (S116) closes, 4 and 7 close, 6 and 8 close.

Group number three, 3 and 9 close. Group number four, 5 and 13 close. Refer to figure 5-17. The contacts operate in a reverse order when the coil is de-energized. This sequence can be best checked by removing the relay from the transmitter and using two or more continuity indicating devices. Connect continuity indicators so that the operation sequence of one group of contacts can be compared to the operation sequence of another group. The operation sequence of contacts within a group can be checked in like manner. If improper sequence is observed, loosen the stationary contact locking nuts, screw the contacts in or out as necessary, and tighten the locking nuts. Check the adjustment of the remaining fixed contacts by applying between 22 volts dc and 28 volts dc to the relay coil (terminals 14 and 15 on the multiterminal connector plug) and observing the position of the movable contacts. The movable contacts should rest firmly against the corresponding fixed contact.

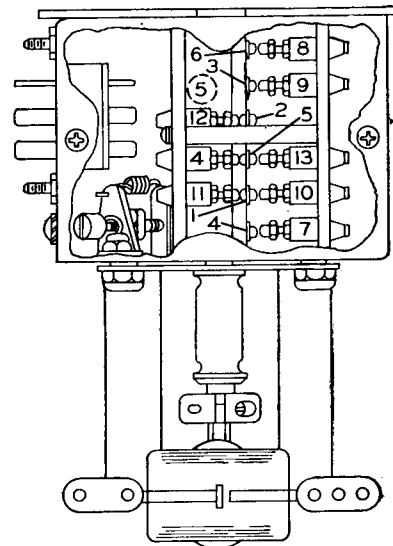

NOTE:  
ALTERNATE CONTACT ARRANGEMENT  
NORMALLY CLOSED STATIONARY CONTACT 4 MAY BE  
FOUND LOCATED IN POSITION (5) IN WHICH CASE  
IT WILL BE CONNECTED TO P102 TERMINAL NO. 5.

Figure 5-17. Keying Relay (K102) Contact Arrangement

The contacts of the relay should be adjusted so that the gap between the movable contacts and the fixed contacts, when the relay is unoperated, is .035 inch. The relay will operate with a minimum of 18 volts dc applied to the coil but will only follow keying of eight impulses per second with this voltage. With 24 volts dc applied to the relay coil the armature will follow keying at 16

impulses per second. With 28 volts dc applied to the relay coil, the armature will follow keying of 35 words-per-minute. The maximum voltage that should be applied to the relay coil is 28 volts dc.

(3) 260 6010 00 (S116)

This vacuum contact is mounted on the keying relay K102. The vacuum contact must be adjusted to operate properly when the relay is adjusted as described in the preceding paragraphs. The vacuum contact make and break action must occur between the operation of contact groups one and two of keying relay K102. Refer to figure 5-18. A single adjusting screw, Item 2, near the multiterminal connector plug permits the adjustment of the mounting yoke so that the movable contact operating arm will operate the arm to close the contact but will not apply enough pressure to damage the vacuum tube. To adjust the mounting yoke, loosen the two hexagon head screws, Item 1, and with the relay unoperated, rotate the adjusting screw, Item 2, in a direction that allows the movable contact within the vacuum tube to rest firmly against the fixed contact that is ordinarily connected to the RECEIVER terminal of the transmitter. When this adjustment has been completed, tighten the two hexagon head screws, Item 1, and apply voltage to the relay coil (Terminals 14 and 15 on the multiterminal connector plug) and, with the relay operated, check the position of the movable contact within the vacuum tube. The movable contact arm should rest firmly against the fixed contact that is ordinarily connected to the COND. terminal on the transmitter. The contact should be firm but the movable arm should not apply enough pressure to the fixed arm to endanger the vacuum seal. The contact pressure must not exceed 23.45 ounces measured at a point  $\frac{3}{4}$  inch from the diaphragm. If the movable contact is applying too much pressure to the fixed contact when the relay is operated, readjust the lower adjusting screw, Item 5, on the side of keying relay K102, opposite the connector plug, to reduce the pressure. If the movable contact is applying too much pressure to the fixed contact when the relay is unoperated, readjust (Item 4).

(4) 410 1700 00 (K103)

The contacts of this relay should be adjusted so that when the relay is unoperated the gap between the fixed contact and the movable contact, Item 17 figure 5-20, page 5-50, is between .045 inch and 0.50 inch. The gap between the

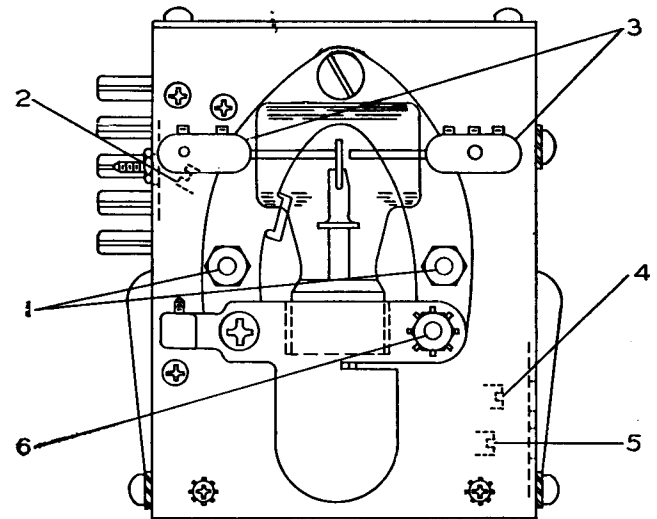

Figure 5-18. Keying Relay (K102) Adjustment

armature and the front edge of the field piece should be  $\frac{3}{32}$  inch.

The armature return spring, Item 8, should be adjusted so that the pressure against the top contacts when the relay is unoperated is between 75 and 80 grams. The pressure between the movable contacts and the fixed contacts when the relay is operated should be between 50 and 55 grams. The dc resistance of the coil is 125 ohms. The minimum voltage required for satisfactory operation is 18 volts dc. The voltage applied to the coil should never exceed 32 volts dc.

(5) 410 1600 00 (K104)

The contacts should be adjusted so that the air gap between the movable contacts, Item 3 figure 5-21, page 5-52, and the fixed contacts, Item 9, is .030 inch. The armature return spring, Item 6, should be adjusted so that the pressure between the movable contacts and the upper fixed contacts is 50 grams. When the relay is operated the pressure between the movable contacts and the lower fixed contacts should be 70 grams. The air gap between the field piece and the armature, as measured at the front edge of the field piece, should be .035 inch. The dc resistance of the coil measured at 20°C (68 degrees F.) is 150 ohms. The relay should operate with a minimum of 18 volts dc and the voltage applied to the coil should never exceed 32 volts dc.

(6) 410 0010 00 (K105)

The air gap between the armature contacts and the fixed contacts should be adjusted to .110 inch. The dc resistance of the coil is 60 ohms. The minimum voltage necessary for satisfactory operation is 22 volts dc. The maximum voltage

that should be applied to the relay coil is 30 volts dc continuous operation.

Adjust contact shaft to have .001 to .005 of an inch end play. Adjust number 6B (*figure 5-22, page 5-54*) normally open contact for .8116 to .9469 ounces minimum pressure in energized position. Set gap at .130 of an inch by adjusting stop nut. Adjust Miniac Switch to make contact just before armature hits core and to break before armature hits stop nut. Adjust armature back pressure to 8 ounces. Adjust number 5 and 7 normally closed contacts for .130 of an inch gap with armature held against core. Adjust number 4 and 6A of double contacts for .111 of an inch minimum gap and .744 ounces minimum pressure. Equalize number 8 contact to match number 4 and 6A contacts. The gap between stop nut and armature should be .003 of an inch minimum. The maximum permissible variation on adjustments is .005 of an inch. The dc resistance of each coil is 30 ohms and the total resistance of the two coils is 60 ohms. The minimum dc voltage necessary for satisfactory operation is 22 volts and maximum voltage is 30 volts.

(7) 401 7900 00 (K2101)

The dc resistance of the coil is 80 ohms. The relay will operate with a minimum of 14 volts ds but will not operate satisfactorily with less than 18 volts dc applied to the coil. A voltage higher than 32 volts dc should not be applied to the coil. The spring, Item 9 *figure 5-23, page 5-55*, should be adjusted so that the minimum armature back tension is not less than 12 ounces. The air gap between the fixed and the movable contacts when the relay is unoperated should be between .035 inch and .045 inch.

(8) 405 2202 00 (K2102)

The contacts should be adjusted so that the air gap between the fixed contacts, Item 1 and 2 *figure 5-24, page 5-56*, and the movable contacts, Item 3, is between .050 inch and .060 inch. The minimum contact pressure should be 135 grams. The relay should operate with 12 volts dc applied to the coil but requires 18 volts dc for satisfactory operation. The maximum voltage that should be applied to the coil is 32 volts dc.

(9) 410 2000 00 (K2105)

The dc resistance of the coil is 125 ohms. The maximum voltage that should be applied to the relay is 32 volts dc. The relay should operate with 18 volts dc applied to the coil. The contacts should be adjusted so that the gap between the movable contact, Item 8 *figure 5-25, page 5-58*, and the fixed contact when the relay is unoperated

is between .045 inch and .050 inch. When the relay is operated the pressure between the fixed contacts and the movable contacts should be between 75 and 80 grams. When the relay is unoperated the pressure between the lower fixed contacts and the movable contacts should be between 50 and 55 grams. The gap between the armature and the front edge of the field piece should be  $\frac{3}{32}$  inch.

(10) RELAY ADJUSTMENT FOR  
ANTENNA LOADING COIL  
CU-32/ART-13A.

The following procedure for repair and maintenance of Vacuum Relay K-2501 is recommended:

a. Inspect relay armature. Proper alignment is obtained when armature is parallel to pole pieces, when depressed to energized position by pushing with finger at center of armature. If not correctly aligned, loosen screws. (No. 1 in *Figure 5-18A*) and align armature parallel to pole pieces. After alignment is made, tighten screws securely.

b. The phenolic push rod, which is the actuating arm between the vacuum switch center contact and relay armature, shall be checked with the relay energized, to make sure that the phenolic push rod centrally clears the feed-through hole in relay case and slotted hole in the cover which is mounted over end of vacuum switch. If necessary, adjustment can be made by loosening the two screws (No. 2 in *Figure 5-18A*) on top of relay armature, then move armature until proper clearance is accomplished. While holding this setting, tighten the two screws on top of armature which had been loosened previously.

c. Check for end play at armature pivot. Armature bearings should be snug with no play. If end play is present, loosen locknut (No. 4 in *Figure 5-18A*) and adjust screw (No. 3 in *Figure 5-18A*) until snug. Tighten locknut (No. 3 in *Figure 5-13*) on ball bearing pivot arm adjusting screw.

**CAUTION**

Adjusting screw (No. 3 in *Figure 5-18A*) should not be tightened against ball bearing. Armature must move freely.

Positive making of vacuum switch contacts is accomplished by having a 0.015 inch over-travel when contacts are closed. The following subparagraphs (*d*) and (*e*) describe the complete adjustments to accomplish 0.015 inch over-travel between: upper stationary and center moveable contacts, and lower stationary and center moveable contacts.

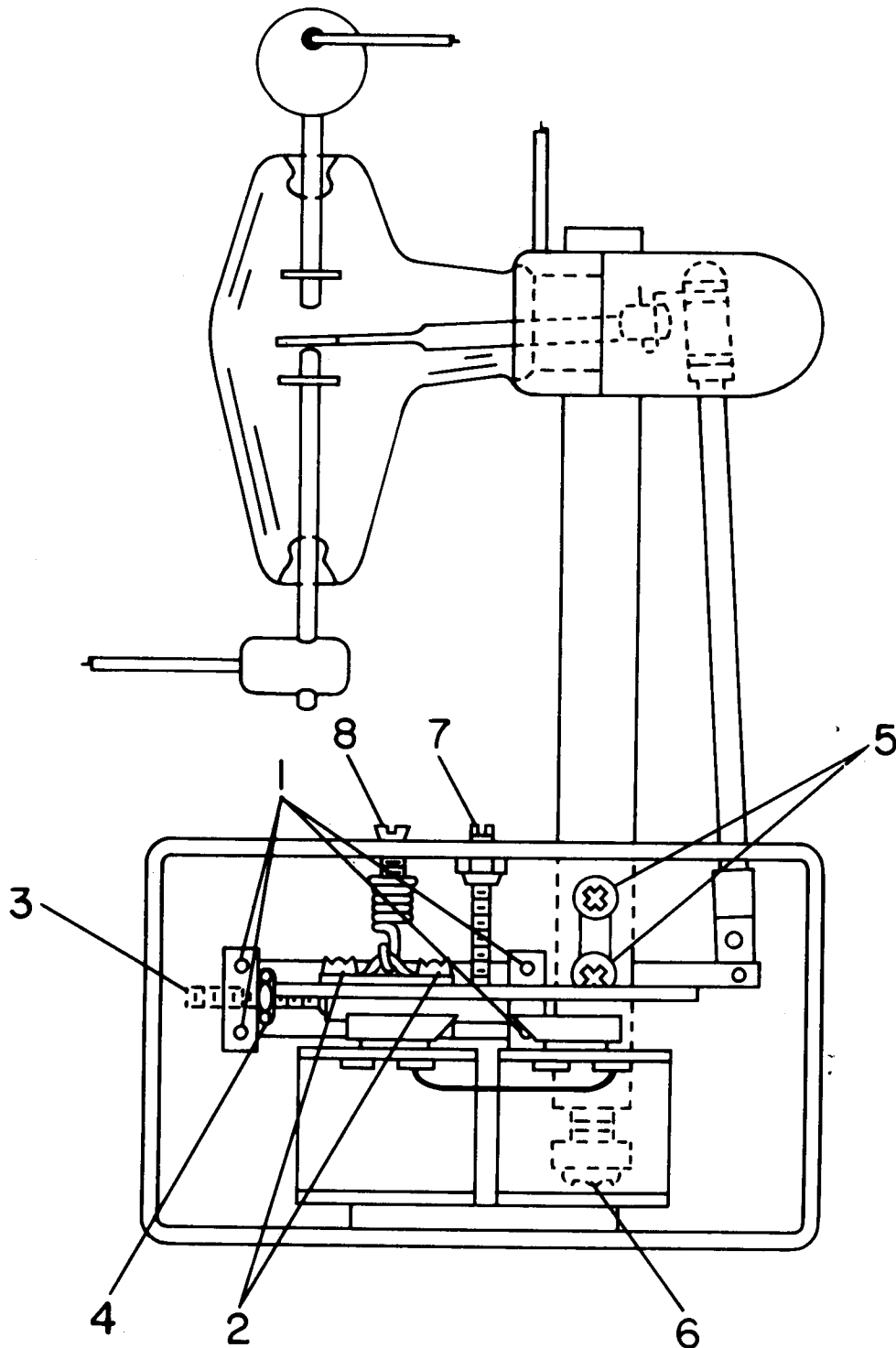

- |            |          |
|------------|----------|
| 1. Screws  | 5. Nuts  |
| 2. Screws  | 6. Screw |
| 3. Screw   | 7. Screw |
| 4. Locknut | 8. Screw |

Figure 5-18A. Relay K2501

**Section V**  
**Paragraph 10**

**AN 08-30ART13-5**

*d.* Energize relay coils with 28 volts DC and place a 0.015 inch shim between bottom of armature and pole piece. Loosen nuts (No. 5 in figure 5-18A) clamping vertical standoff insulator and hook up ohmmeter between the moveable center contact and upper contact stationary contact of vacuum switch. Then adjust standoff insulator adjusting screw (No. 6 in Figure 5-18A) until a closed circuit is made. After adjustment, tighten the two nuts previously loosened, and remove shim.

*e.* Place a 0.015 inch shim between top of arma-

ture and bottom of armature travel adjustment set screw. De-energize relay coils and hook up ohmmeter between the moveable center contact and the lower stationary contact of vacuum switch. Adjust armature travel set screw (No. 7 in Figure 5-18A) until a closed circuit is made. After adjustment remove .015 inch shim.

*f.* Armature return spring should have enough tension to lift armature quickly when relay is de-energized. If adjustment is necessary, adjust screw (No. 8 in Figure 5-18A) for proper armature spring tension.



d. PARTS LIST FOR 410 0008 00 KEYING RELAY (K102)  
(Guardian Type G-36427)

<u>Item</u>	<u>Quantity</u>	<u>Guardian Part No.</u>	<u>Description</u>
1	1	BR-599-A	Contact Mounting Bracket
2	1	2522-4	Solder Lug
3	1	SW-57-A	Adjustable Contact
4	2		Number 4 Split Lock Washers
5	2		4-40 x 3/8 Binder Head Machine Screw
6	1		4-48 x 3/16 Hexagon Nuts
7	2		4-40 x 3/16 Hexagon Nuts
8	1	BU-110	Vacuum Tube Terminal
9	1	BM-161	Mounting Plate
10	1	BU-102	Vacuum Tube Terminal
11	1	CS-142	Adjusting Bracket Spring
12	1	CV-81	Tube End Cover
13	1	CV-94	Cover (Top)
14	1	N-19	Hexagon Cap Nut
15	1	ST-157	Lever Bearing Stud
16	1	SW-54	Tube Adjusting Screw
17	2	SW-56	Adjustment Screw
18	2	SW-60	Insert Screw
19	1	X-380	Rubber Cushion
20	1	X-382	Contact Plug
21	1	X-399	Vacuum Switch
22	6		4-40 x 3/8 Flat Head Machine Screw
23	6		4-48 x 1/16 Bristo Head
24	1		Number 8 External Shakeproof Washer
25	1	CVA-20	Side Cover Assembly
26	1	CVA-21	Side Cover Assembly
27	1	X-386	Terminal Block Assembly
28	1	X-381	Collar & Arm Assembly
29	1	BRA-97	Stop Bracket Assembly
30	1	BRA-98	Tube Adjusting Bracket Assembly
31	1	FIA-85	Coil & Armature Assembly
32	2		6-32 x 1/4 Binder Head Machine Screw
33	1		8-32 x 5/8 Binder Head Machine Screw
34	6		4-40 x 5/16 Binder Head Machine Screw
35	6		4-40 x 3/16 Binder Head Machine Screw
36	2		4-40 x 3/16 Flat Head Machine Screw
37	1		2-56 x 3/8 Round Head Machine Screw

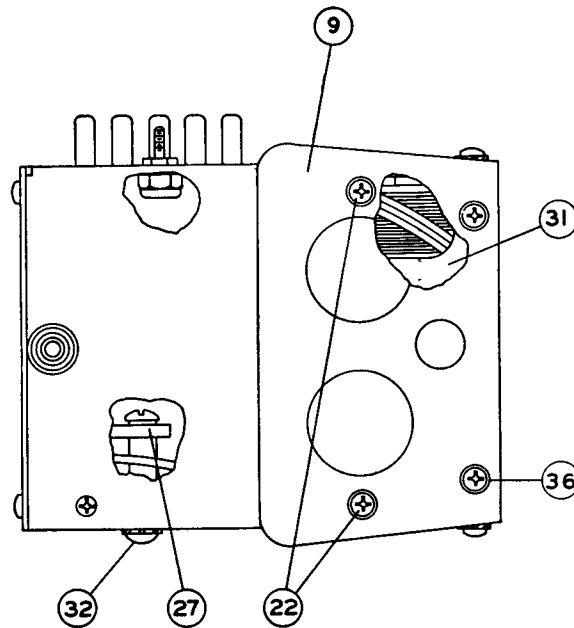
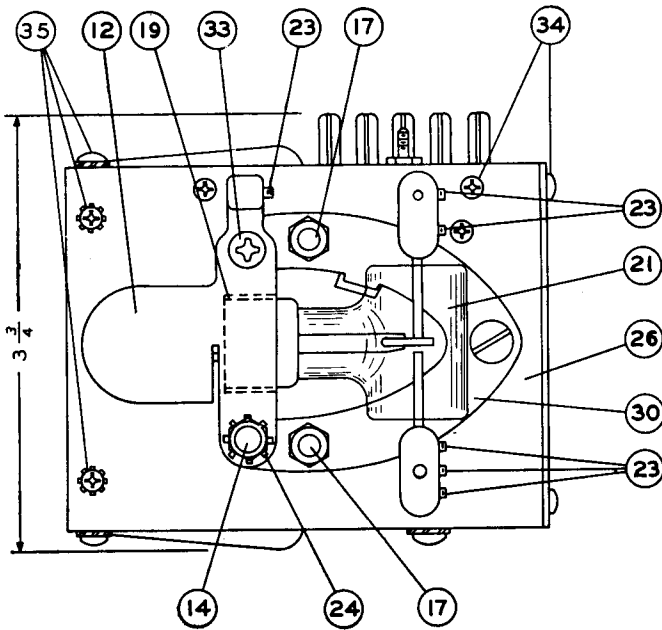
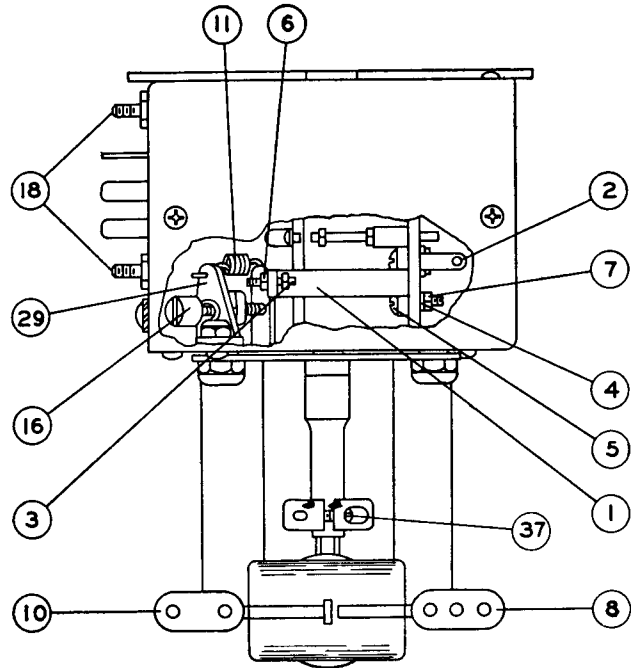
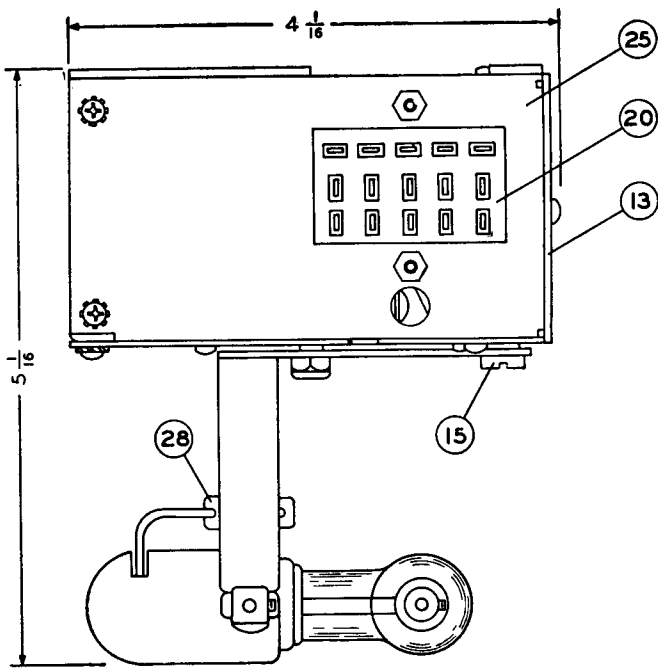

Figure 5-19. 410 0008 00 Keying Relay (K102)

e. PARTS LIST FOR 410 1700 00 CW EMISSION CONTROL RELAY (K103)  
(Guardian Type G-32811)

<u>Item</u>	<u>Quantity</u>	<u>Guardian Part Number</u>	<u>Description</u>
1	1	BRA-101	Mounting Bracket Assembly
2	1	FI-64	Field Piece
3	1	BR-487A	Armature Retainer Bracket
4	2	SPA-85	Spacers
5	1	CXA-829	A-2 Contact Assembly
6	1	B-179	Contact Spring Mounting Bar
7	1	X-389	Counterweight
8	1	CS-122	Armature Spring
9	1	BBA-76	Contact Bracket & Block Assembly
10	1	FW-16	Bakelite Washer
11	1	MW-47-D	Plain Brass Washer
12	2	FW-90	Cushion Washers
13	4	FW-91	Cushion Washers
14	1	CS-18-J	Separator Plate
15	1	CX-21	Lug Adapter
16	1	ARA-424	Armature Assembly
17	2	CX-350	Contact Spring Assembly
18	1	BRA-99-A	Armature Bracket Assembly
19	1	SP-222-W	Coil Assembly
20	1		8-32 x 1/2 Binder Head Screw
21	1		8-32 x 3/16 Binder Head Screw
22	2		Number 8 Shakeproof
23	2		5-40 x 5/8 Fillister Head Screw
24	2		Number 5 Split Lock Washers
25	2		2-56 x 7/8 Round Head Screw
26	2		2-56 x 3/8 Round Head Screw
27	2		2-56 x 7/16 Round Head Screw
28	6		Number 2 Split Lock Washers
29	4		2-56 x 3/16 Hexagon Nuts
30	2		2-56 x 1/4 Special Machine Screw
31	2		2-56 x 1/4 Round Head Screw

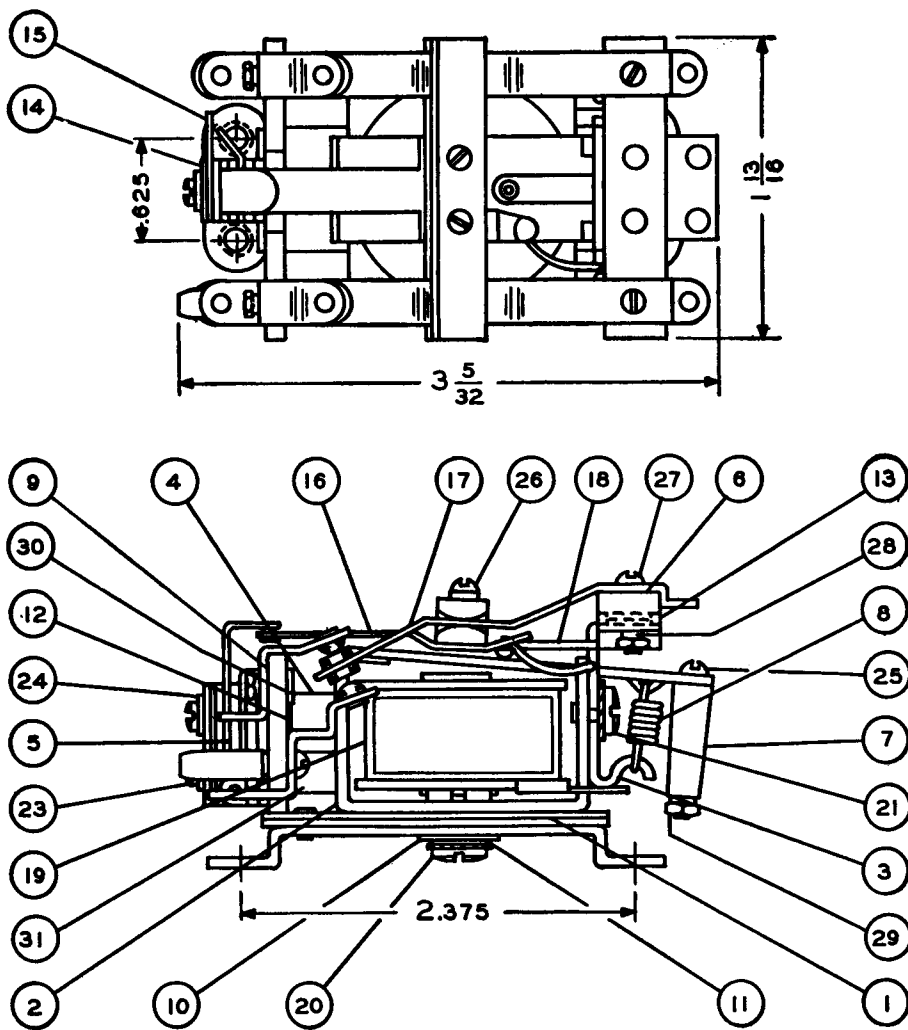

Figure 5-20. 410 1700 00 CW Relay (K103)

f. PARTS LIST FOR 410 1600 00 VOICE EMISSION CONTROL RELAY (K104)  
(Guardian Type G-32734)

<u>Item</u>	<u>Quantity</u>	<u>Guardian Part Number</u>	<u>Description</u>
1	1	BR-611-B	Relay Mounting Bracket
2	1	FI-48	Field Piece
3	1	ARA-319	Armature Assembly
4	1	X-241	Counterweight
5	1	BR-487	Armature Retainer Bracket
6	1	CS-120	Armature Spring
7	1	US-128-C	Armature Stop Bracket
8	1	BBA-74	Contact Block & Spring Assembly
9	1	BBA-61	Contact Bracket & Block Assembly
10	1	BB-141	Spacer Block
11	1	FP-23	Coil Insulator
12	1	SP-220-W	Coil Assembly
13	1		8-32 x 3/8 Binder Head Screw
14	1		8-32 x 3/16 Binder Head Screw
15	2		6-32 x 3/8 Binder Head Screw
16	2		6-32 x 7/16 Binder Head Screw
17	1		2-56 x 3/16 Round Head Screw
18	2		2-56 x 5/8 Round Head Screw
19	2		2-56 x 3/16 Hexagon Nuts

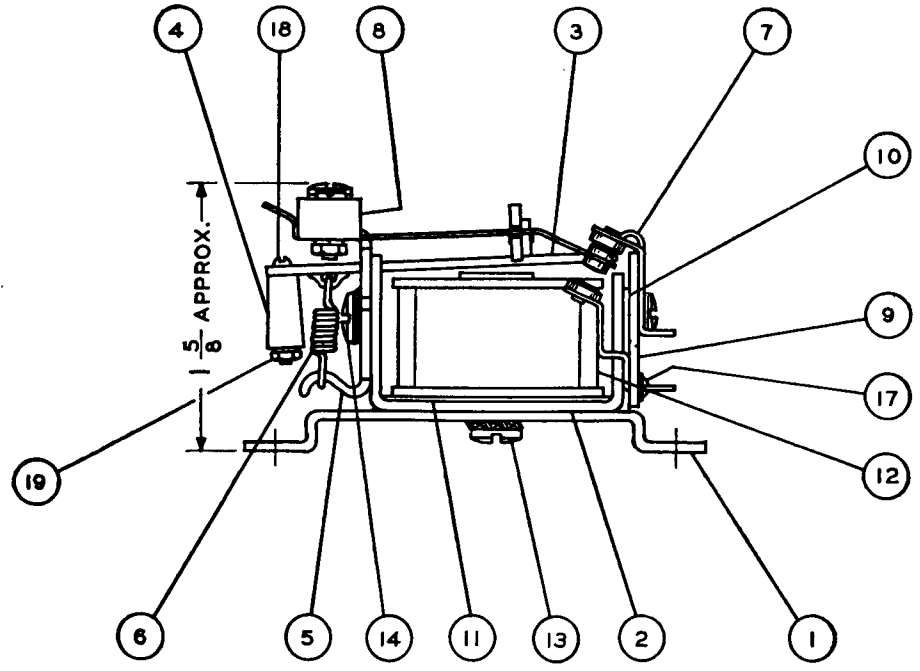
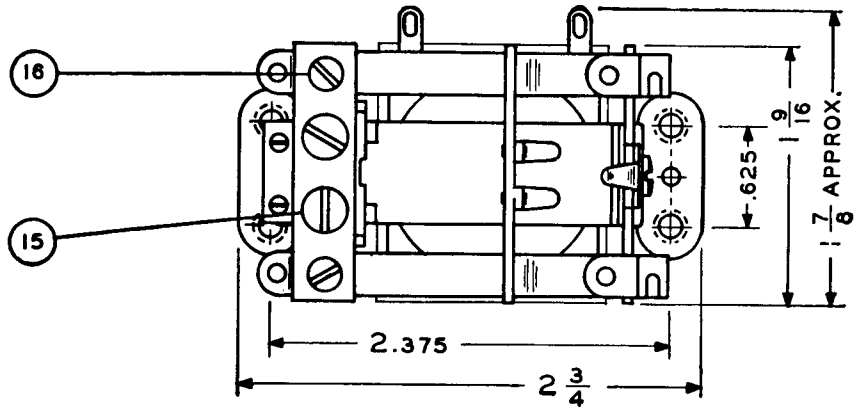
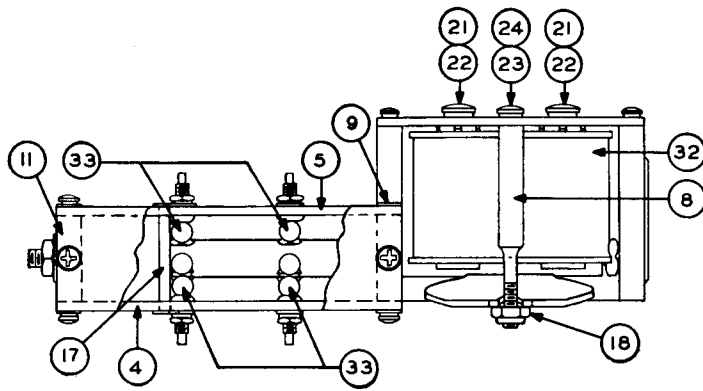
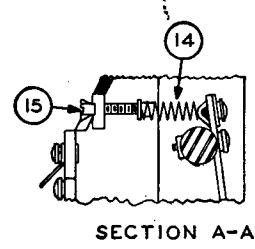
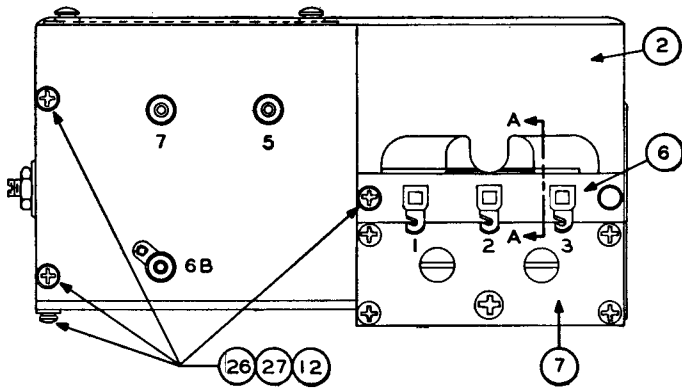

Figure 5-21. 410 1600 00 "Voice" Relay (K104)

g. PARTS LIST FOR 410 0010 00 CHOKE SHORTING RELAY (K105)  
(Guardian Type G-36427)

<u>Item</u>	<u>Quantity</u>	<u>Guardian Part Number</u>	<u>Description</u>
1	1	SFA-28	Shaft and Armature Assembly
2	1	F-98	Frame
3	1	X-572	Miniac Switch
4	1	CVA-49	Cover Assembly
5	1	CVA-50	Cover Assembly
6	1	TBA-43	Terminal Block Assembly
7	1	FI-110	Field Plate
8	1	ST-222	Armature Pilot's Stud
9	(as required)	SPA-140	Spacer
10	1	See Chart	Metal Side Cover
11	1	CV-157	Mykroy Side Cover
12	12	MW-47-M	Plain Washers
13	1	SW-88-A	Cone Point Set Screw
14	1	CS-36-5	Spring and Bushing Assembly
15	1	A-68	Adjusting Screw
16	1	SW-88	Cone Point Set Screw
17	1		Piece Tinned Copper Wire .081 Diam. x 1-3/16 Long
18	1	68M62	Elastic Stop Nut (Number 6)
19	1	20ANJC48	Lead 2-1/2 inches long
20	1	20ANJC48	Lead 2 inches long
21	2		8-32 x 3/8 Binder Head Machine Screw (National Coarse -2) (Steel)
22	2		Number 8 Splitlock Washers (Phosphorous Bronze)
23	1		6-32 x 5/16 Phillips Binder Head Machine Screw. (National Coarse-2)
24	1		Number 6 Splitlock Washer Phosphorous Bronze.
25	2		Number 10-32x5/16x3/32 Brass Hexagonal Machine Screw Nuts. (National Fine-2)
26	12		4-40x5/16 Phillips Binder Head Machine Screw. (National Coarse-2)
27	16		Number 4 Splitlock Washers Phosphorous Bronze
28	2		4-40x3/16 Phillips Binder Head Screw. (National Coarse-2)
29	2		4-40x1-5/16 Phillips Binder Head Machine Screw. (National Coarse-2)
30	2		2-56x7/16 Round Head Machine Screw. (National Coarse-2) (Brass)
31	2		Number 2 Splitlock Washers Phosphorous Bronze
32	2	SP-2/6-W	Coil Assemblies
33	6	ST-221	Threaded Contact Stud
34	2	CX-676	Contact Spring Assemblies



WIRING DIAGRAM

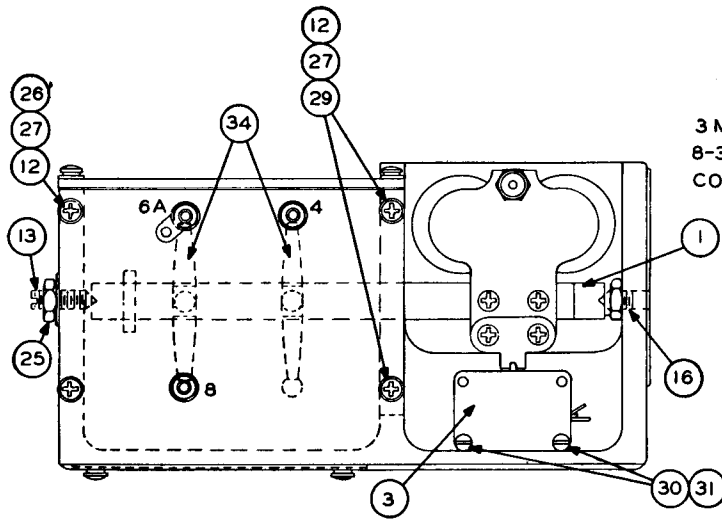
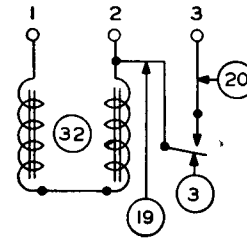

3 MOUNTING HOLES  
8-32 TAP (NATIONAL  
COARSE - 2)

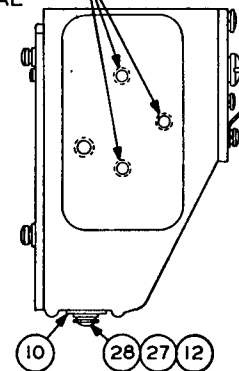

Figure 5-22. 410 0010 00 Choke Shorting Relay (K105)



AN 08-30ART13-5

k. PARTS LIST FOR 401 7900 00 DYNAMOTOR INPUT RELAY (K2101)  
(Guardian Type G-31199)

<u>Item</u>	<u>Quantity</u>	<u>Guardian Part Number</u>	<u>Description</u>
1	1	PLA-40	Plunger Assembly
2	1	BRA-62	Mounting Block Assembly
3	1	BRA-82-A	Contact Bracket Assembly
4	1	BRA-82-B	Contact Bracket Assembly
5	2	BA-222	Upturned Lugs
6	4	SPA-66	Main Spacer (Inner)
7	4	SPA-67	Main Spacer (Outer)
8	1	BB-97-A	Contact Bracket Mounting Base
9	1	CS-121	Plunger Spring
10	4	22M62	Number Six Elastic Stop Nuts
11	1	Z-198	Solenoid Assembly
12	2		10-32 x 5/16 Round Head Screw
13	2		8-32 x 1/4 Binder Head Screw
14	2		Number 10 Split Lock Washer

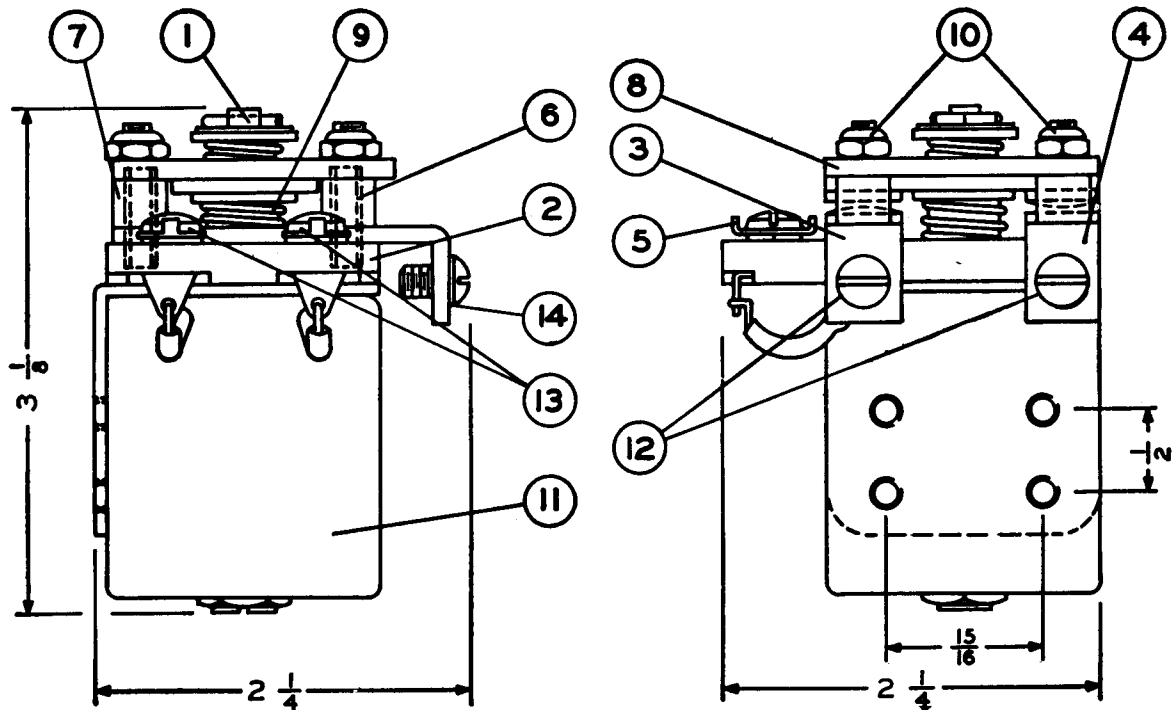

Figure 5-23. 401 7900 00 Dynamotor Input Relay (K2101)

i. PARTS LIST FOR 405 2202 00 PRIMARY POWER CONTACTOR (K2102)  
(Guardian Type G-32793)

<u>Item</u>	<u>Quantity</u>	<u>Guardian Part Number</u>	<u>Description</u>
1	1	CXA-831	Contact Assembly
2	1	CXA-832	Contact Assembly
3	1	ARA-427	Armature Assembly
4	1	AH-27-A	Armature Hinge
5	1	PI-35	Armature Pin
6	1	CS-160	Spring
7	1	X-241	Counterweight
8	1	BR-611-B	Relay Mounting Bracket
9	2	CX-18-I	Metal Separator
10	1	F1A-87	Field & Coil Assembly
11	4		5-40 x 13/32 Fillister Head Screw
12	1		8-32 x 1/4 Binder Head Screw
13	2		2-56 x 3/8 Round Head Screw
14	4		Number 5 Split Lock Washers
15	1		Number 8 Shakeproof Washer
16	2		Number 2 Shakeproof Washer

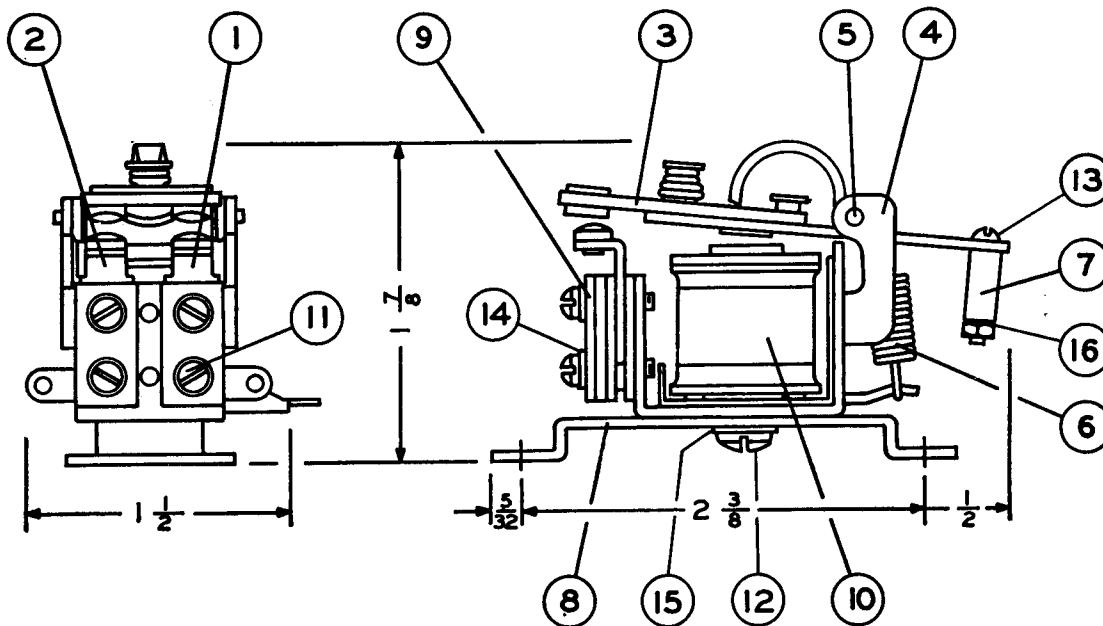

Figure 5-24. 405 2202 00 Primary Power Contactor (K2102)

j. PARTS LIST FOR 410 2000 00 POWER CHANGE RELAY (K2105)  
(Guardian Type G-33375)

<u>Item</u>	<u>Quantity</u>	<u>Guardian Part Number</u>	<u>Description</u>
1	1	ARA-425	Armature Assembly
2	1	B-179	Contact Spring Mounting Bar
3	1	BBA-76	Contact Bracket & Block Assembly
4	1	BR-487-A	Armature Retainer Bracket
5	1	BRA-99-A	Stop Bracket Assembly
6	1	BRA-101	Mounting Bracket Assembly
7	1	CS-122	Armature Spring
8	2	CX-350	Contact Spring Assembly
9	1	FI-64	Field Piece
10	1	FW-16	Bakelite Washer
11	2	FW-90	Washers
12	4	FW-91	Washers
13	2	SPA-85	Spacers
14	1	X-389	Counterweight
15	1	MW-47-D	Brass Washer
16	1	SP-221-W	Coil Assembly
17	1		8-32 x 1/2 Binder Head Screw
18	1		8-32 x 3/16 Binder Head Screw
19	2		Number 8 Shakeproof Washer
20	2		2-56 x 3/8 Round Head Screw
21	2		2-56 Round Head Screw
22	2		5-40 x 1/2 Fillister Head Screw
23	2		2-56 x 7/8 Round Head Screw
24	4		2-56 x 3/16 Hexagon Nuts
25	2		2-56 x 5/16 Special Machine Screw
26	2		2-56 x 5/16 Round Head Screw

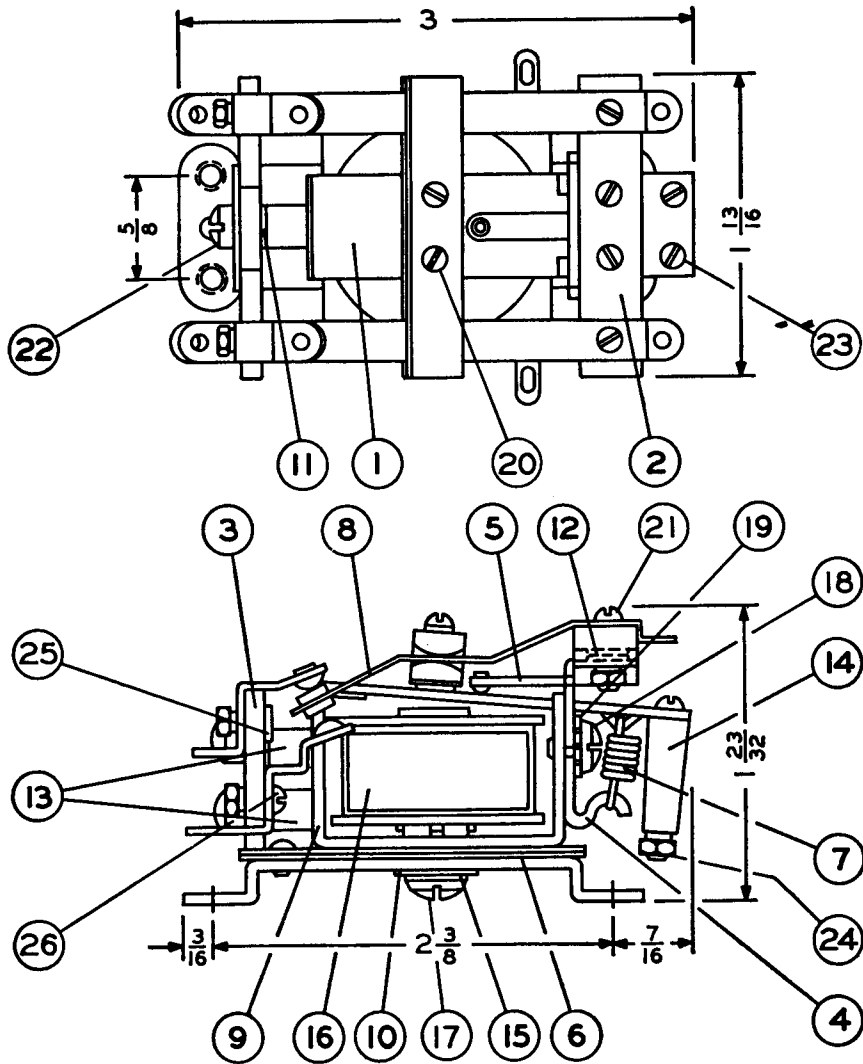

Figure 5-25. 410 2000 00 Power Change Relay (K2105)

AN 08-30ART13-5

k. PARTS LIST FOR 274 1400 00 TELEGRAPH KEY (S603)  
(Guardian Type G-33423)

<u>Item</u>	<u>Quantity</u>	<u>Guardian Part Number</u>	<u>Description</u>
1	1	I-203	Insulating Spacer
2	1	PI-46	Pin
3	1	SF-63	Key Shaft
4	1	X-385	Telegraph Key Knob
5	1	CS-147	Compression Spring
6	1	RG-34	Clincher Ring
7	1	CXA-833	Special Contact Assembly
8	1	BMA-96	Contact & Base Assembly
9	1	SW-57-A	Adjustable Contact
10	1		Soldering Lug
11	1		Number 12 Transflex Tubing

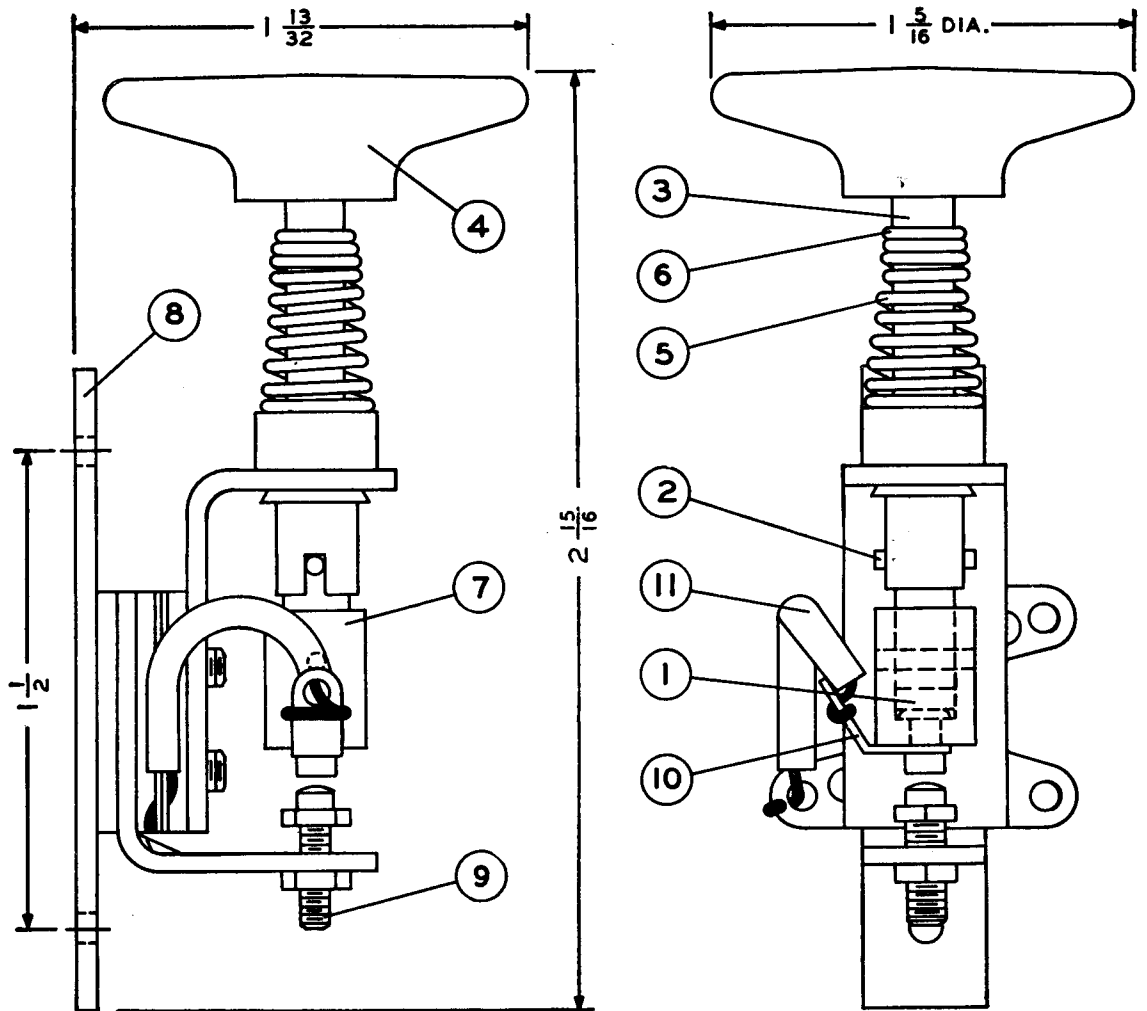

Figure 5-26. 274 1400 00 Telegraph Key (S603)

7. PARTS LIST FOR 508 0818 31 AUTOTUNE MOTOR (B2801)  
(Emerson Type NY-818C-A)

<u>Item</u>	<u>Quantity</u>	<u>Emerson Part Number</u>	<u>Description</u>
1	1	94716-D	Brush Holder End Bracket
2	2	96580-A	Capacitor
3	1	96953-A	Terminal Assembly
4	2	96030-A-15	Terminal Screws
5	2	96509-A	Capacitor Covers
6	3	96030-A-14	Brush Holder Mounting Screws
7	2	96254-A	Brush Holder Cap
8	2	94718-A	Brush
9	1	94717-B	Brush Holder
10	1	3520-14	Bearing Load Spring
11	1	S1DD7	Bearing
12	2	95320-A	Brush Spring
13	1	94713-B	Motor Yoke
14	1	94715-B	Armature Assembly (without bearing)
15	1		Field Coil
16	1	96065-A-17	Thrust Washer
17	1	37DD	Bearing
18	2	94719-A	Motor Stud
19	1	94714-D	End Bracket
20	2		Pole Piece Assembly
21	4		Pole Piece Screws

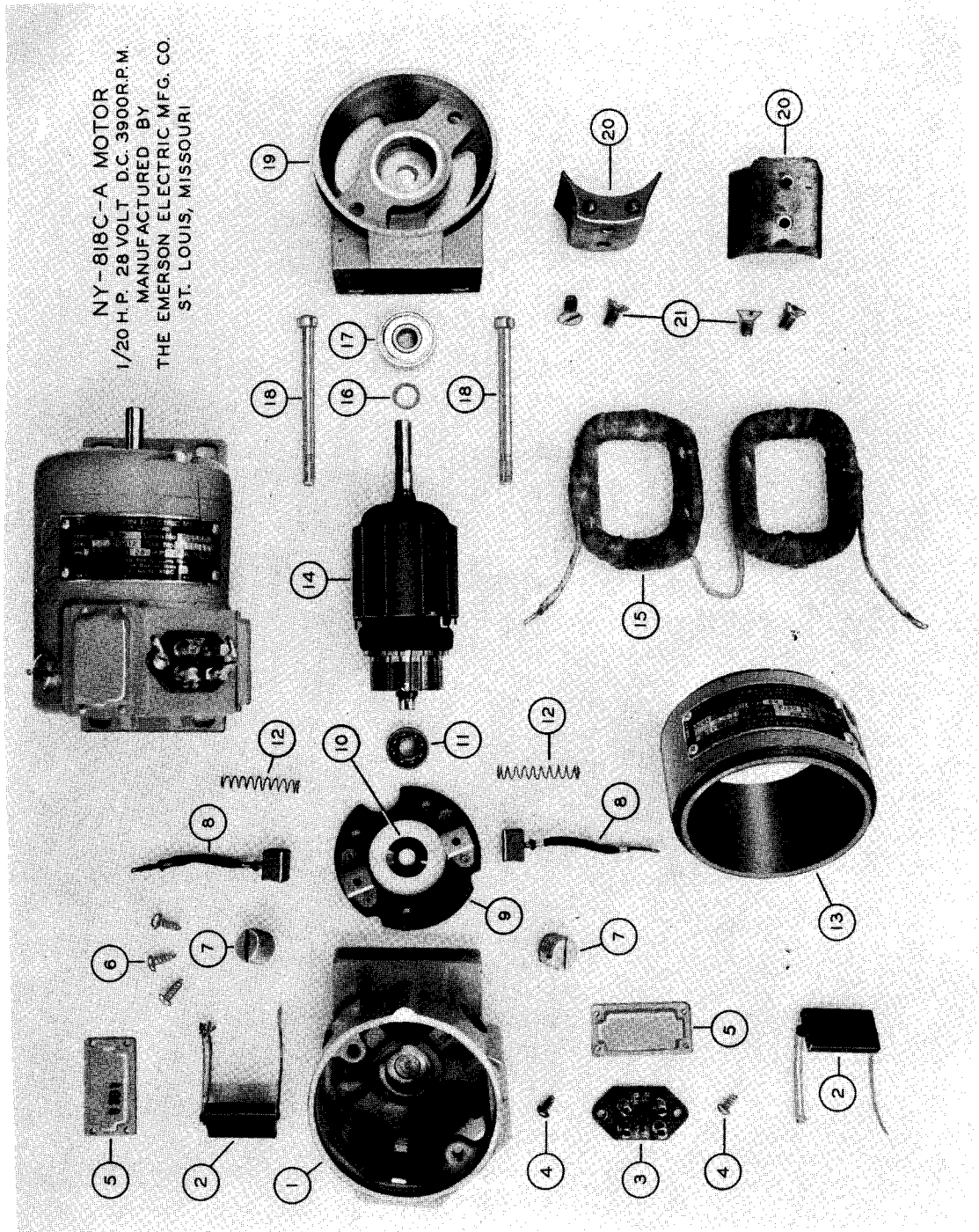

Figure 5-27. Emerson Type NY-818C-A Motor Parts

AN 08-30ART13-5

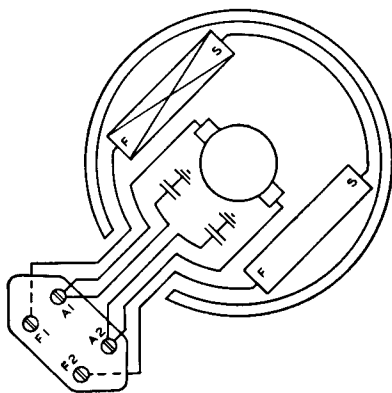
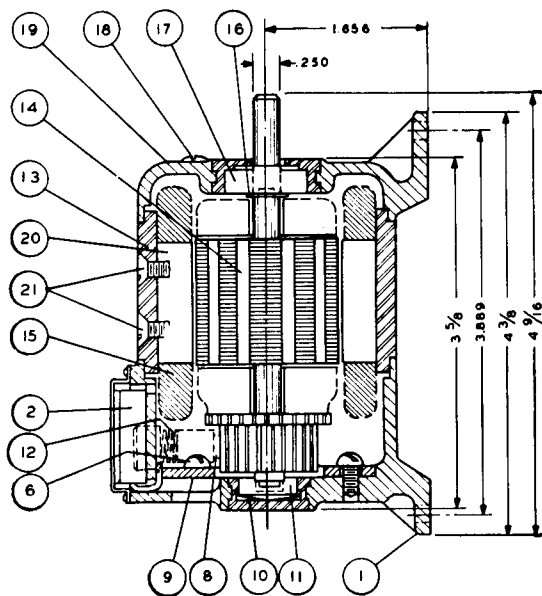
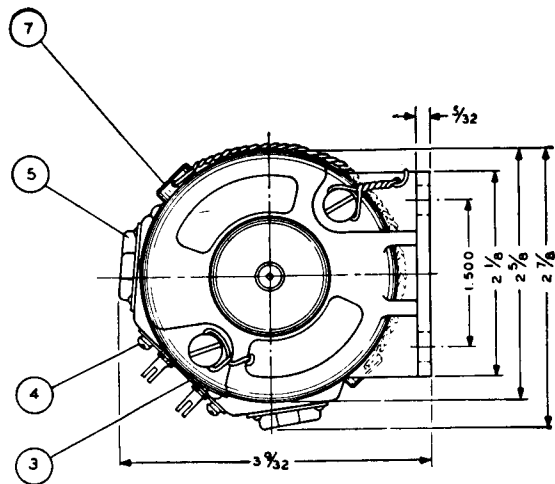

Figure 5-28. Emerson Type NY-818C-A Motor



AN 08-30ART13-5

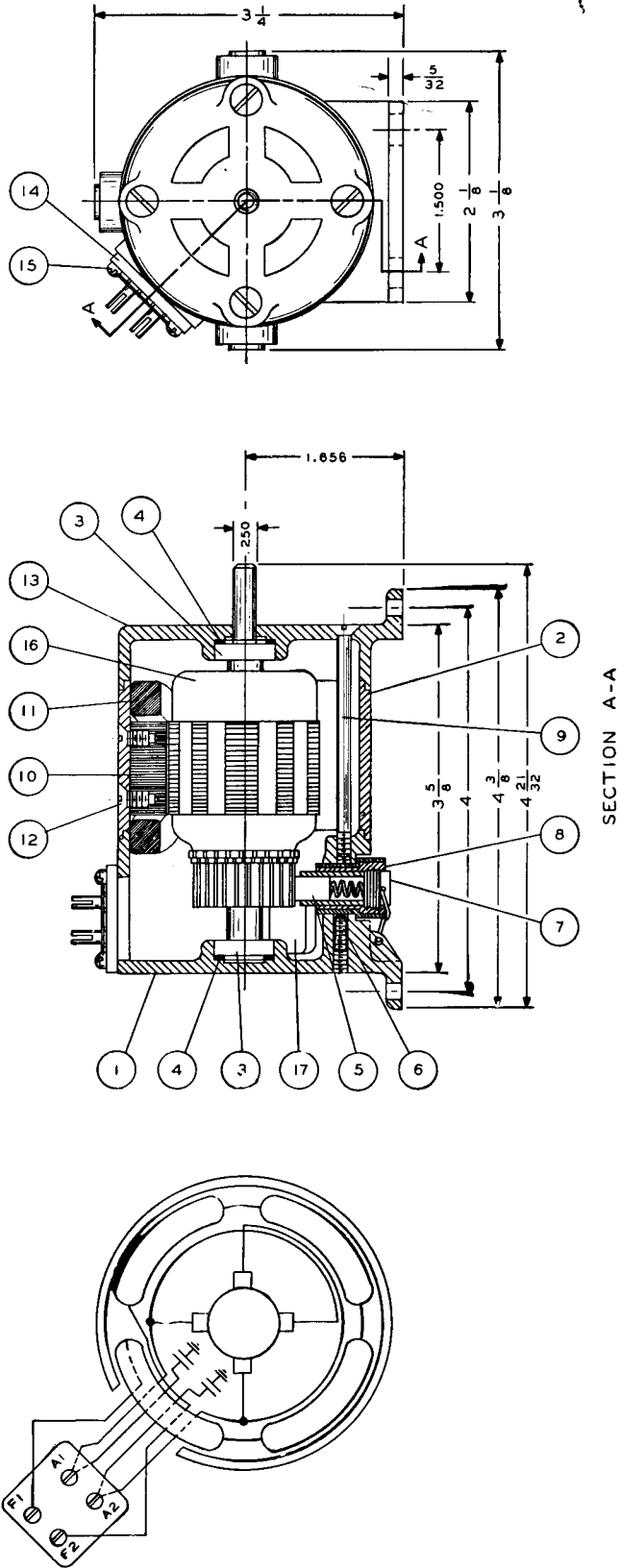

Figure 5-29. Ohio Type NY-818C-B Motor

m. PARTS LIST FOR 508 0818 32 AUTOTUNE MOTOR (B2901)  
(Ohio Type NY-818C-B)

Item	Quantity	Ohio Part Number	Description
1	1	B-22411	Commutator Cover
2	1	C-4678	Field Ring
3	2	77-R-4	Ball Bearing
4	2	D-10321	Spring Washer
5	4	D-5699	Brush
6	8		Allen Standard Set Screw 10-32 x 3/16
7	4	D-3689	Brush Box Cap
8	4	D-5726	Brush Box
9	4		Flat Head Standard Machine Cover Screw 8-32 x 2-7/16
10	4	D-5701	Field Pole
11	1	W-12692	Field Coil (Assembly)
12	8		Flat Head Standard Machine Field Pole Screw 8-32 x 5/16
13	1	B-22412	Pully Cover
14	1	W5730	Terminal Board
15	4	D-31053	Terminal Board Screw
16	1	D-65024	Armature
17	2	1WS	.0035 mf Dubilier Capacitor

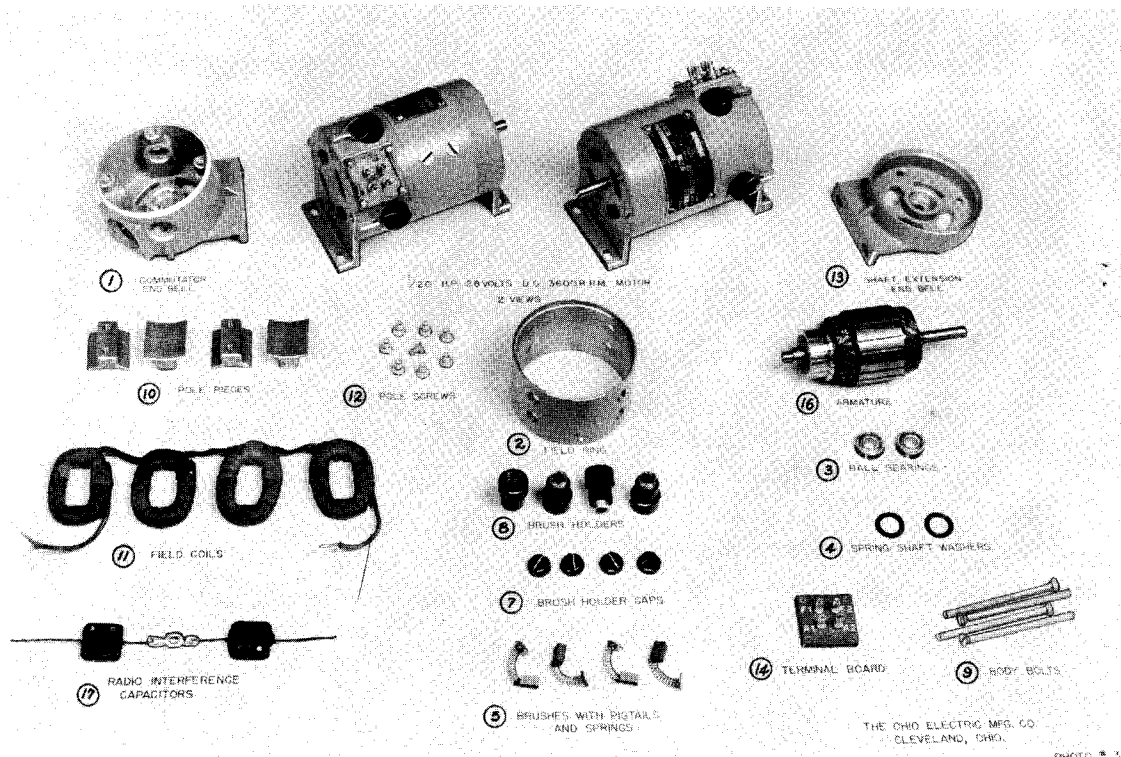

Figure 5-30. Ohio Type NY-818C-B Motor Parts

AN 08-30ART13-5

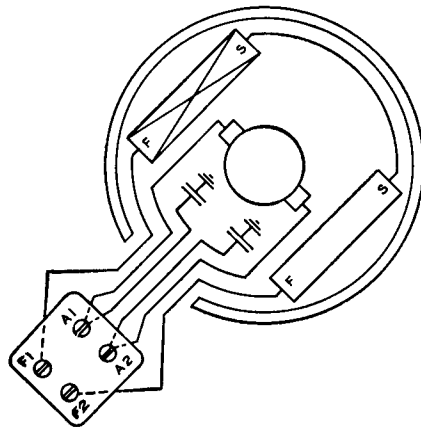
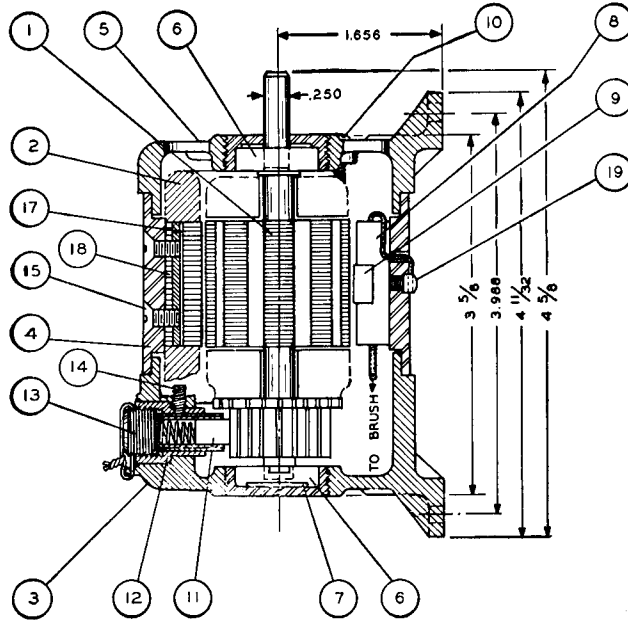
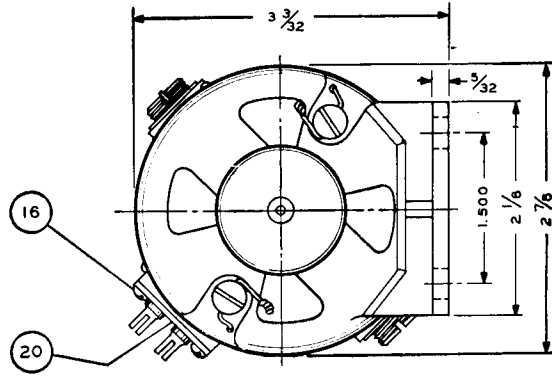
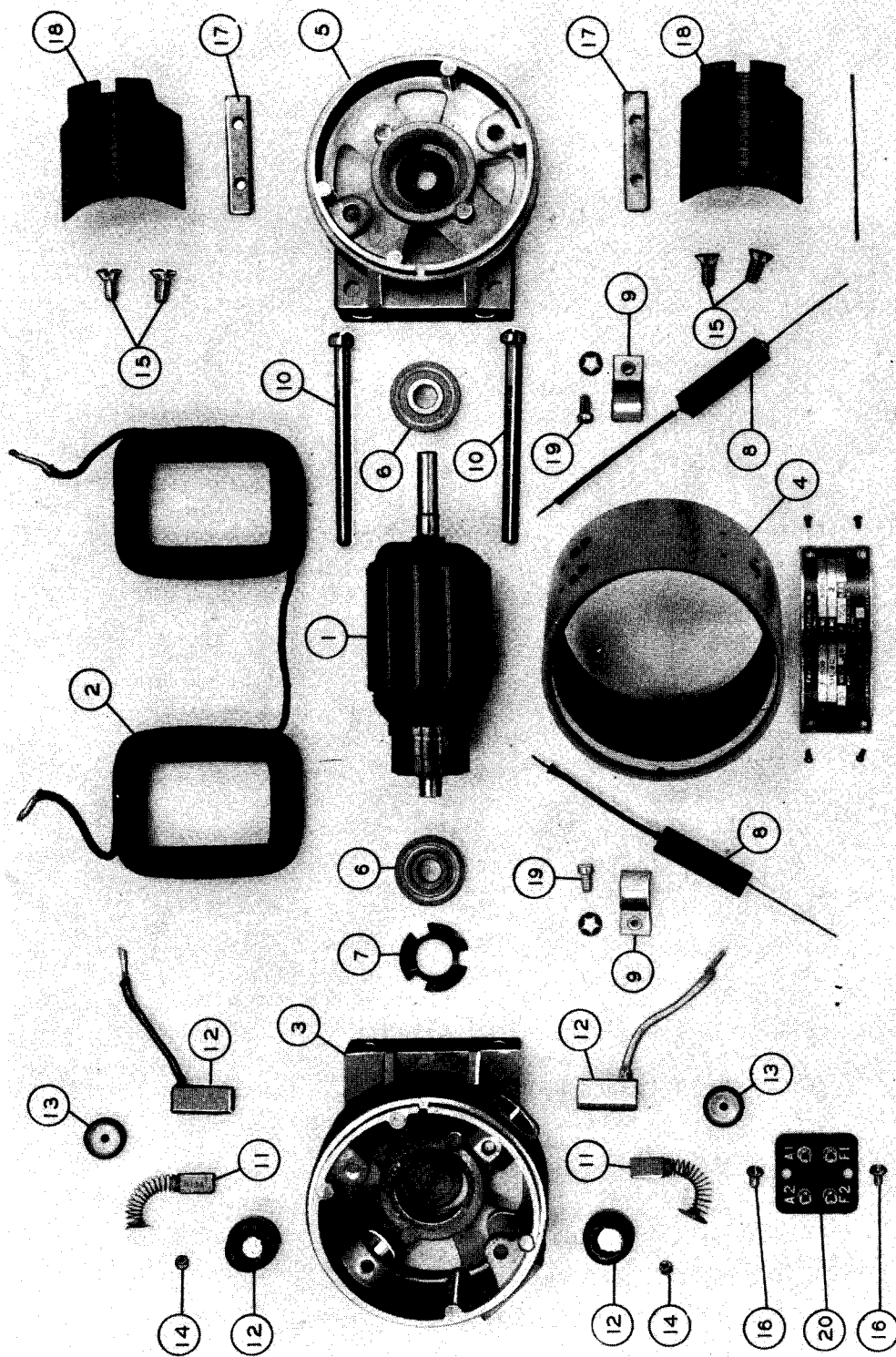

Figure 5-31. Fractional Type NY-818C-C Motor

n. PARTS LIST FOR 508 0818 32 AUTOTUNE MOTOR (B101)  
(Fractional Type NY-818C-C)

<u>Item</u>	<u>Quantity</u>	<u>Fractional Part Number</u>	<u>Description</u>
1	1	F-860	Armature Assembly (without bearing)
2	1	F-875	Field Coil
3	1	F-801	Brush Holder End Bracket
4	1	F-803	Motor Yoke
5	1	F-802	End Bracket
6	2	N.D.77037	Ball Bearing
7	1	S-102	Bearing Load Spring
8	2	F-840	Capacitor
9	2	F-812	Capacitor Bracket
10	2	F-815	Motor Stud
11	2	F-811	Brush Assembly
12	2	F-85	Brush Holder
13	2	F-825	Brush Holder Cap
14	2	SCR-209	Brush Holder Screw
15	4	SCR-206	Pole Screw
16	2	SCR-210	Terminal Screws
17	2	F-805	Pole Key
18	2	F-870	Pole Piece Assembly
19	2	SCR-208	Capacitor Bracket Screw
20	1	F-821	Terminal Base
	4	F-820	Terminals



NY-818 C-C MOTOR 1/20 H.P. 28 VOLT DC. 3500 RPM.  
 MANUFACTURED BY  
 THE FRACTIONAL MOTORS CO. CHICAGO, ILLINOIS

Figure 5-32. Fractional Type NY-818C-C Motor Parts

**Section V**  
**Paragraph 10**

**AN 08-30ART13-5**

**o. PARTS LIST FOR TYPE DY-11/ART-13 DYNAMOTOR POWER UNIT DYNAMOTOR**  
(Russell Type 502 D3 COA Part No. 231 0003 00)

<u>Item</u>	<u>Symbol Designation</u>	<u>Quantity</u>	<u>Russell Part Number</u>	<u>Description</u>
1		1	13608	End Shell Assembly (Input End)
2		1	13610	End Shell Assembly (Output End)
3		1	13605	Frame & Coils Assembly
4	C2606A, C2606B C2607A, C2607B	4	13647	Capacitor (.005 MF, 1000 TV 600 WV)
5		8	6826	Machine Screw Number 8-32 x 1/2 Long Round Head
6		(As required)	13422	Thrust Washer 49/64 x 1-1/4 x .005 Fibre
7		(As required)	13423	Thrust Washer 49/64 x 1-1/4 x .010 Fibre
8		18	6778	Lockwasher S.A.E. Standard for Number 8 Screw
9		1	13632	Bearing Cover (Input End)
10		1	13633	Bearing Cover (Fan End)
11		1	13881	Bearing Support (Long)
12		1	13604	Bearing Support (Short)
13	E2601A, E2601G	2	13836	Input Brush Positive
14	E2601B, E2601H	2	13836-A	Input Brush Negative
15		4	13092	Brush Holder Cap Input
16	E2601E	1	13741	HV Output Brush Positive
17	E2601F	1	13741-A	HV Output Brush Negative
18		4	12813	Brush Holder Cap HV & LV
19	E2601C	1	13742	LV Output Brush Positive
20	E2601D	1	13742-A	LV Output Brush Negative
21		1	13643	Fan Assembly (Includes Set Screws)
22		4	13686	Screw Round Head 5-3/8 Long Number 8-32
23		1	13650	Ground Strip
24		4	6741	Nut Number 8-32 11/32 Hexagon x 1/8 thick
25		1	13624	Armature & Bearing Assembly
26		2	6822	Screw Number 10-32 x 7/16 Long Round Head
27		4	13810	Pole Assembly
28		4	13685	Pole Retaining Bar
29		12	6827	Screws Number 1/4-20 x 1/2 Long Flat Head
30		1	13812-12813	Coil Assembly (1 each Number 13683-13684)
31		1	13884	Lead Restrainer 15/16 x 9/16 x .062
32		2	6829	Screw Number 8-32 x 1/4 Long Round Head
33		2	6820	Lockwasher S.A.E. Standard Light for Number 8 Screw
34		2	13401	Bearings
35		2	13420	Oil Shield
36		6	6760	Nut Number 10-32 x 1/2 Hexagon x 1/8 thick
37		6	6791	Lockwasher S.A.E. Standard for Number 10 Screw

PARTS LIST FOR TYPE DY-11/ART-13 DYNAMOTOR POWER UNIT DYNAMOTOR (Continued)  
(Russell Type 502 D3 COA Part No. 231 0003;00)

Item	Symbol Designation	Quantity	Russell Part Number	Description
38		4	6758	Screw Number 10-32 x $\frac{3}{8}$ Long Round Head
39		2	6839	Fan Set Screw Number 10-32 x $\frac{3}{8}$ Long
40		2	13834	Brush Holder & Insulator LV
41		2	13876	Brush Holder & Insulator HV
42		4	13616	Brush Holder & Insulator Input
43		16	6732	Brush Holder Set Screw Number 8-32 x $\frac{1}{4}$ Long
44		6	6840	Binding Head Screw Number 8-32 x $\frac{1}{4}$ Long
45	C2608, C2609, C2610	3		Capacitor .006 mf 5000 TV
46		2		Grounding Straps
47		1		Connector Bracket
48		3		Screw Number 6-32 x $\frac{3}{4}$ Long Flat Head
49		6		Lockwasher S.A.E. Standard for Number 6 Screw
50		2		Screw Number 6-32 x $\frac{1}{4}$ Long Flat Head
51		1		Screw Number 6-32 x $\frac{1}{2}$ Long Flat Head

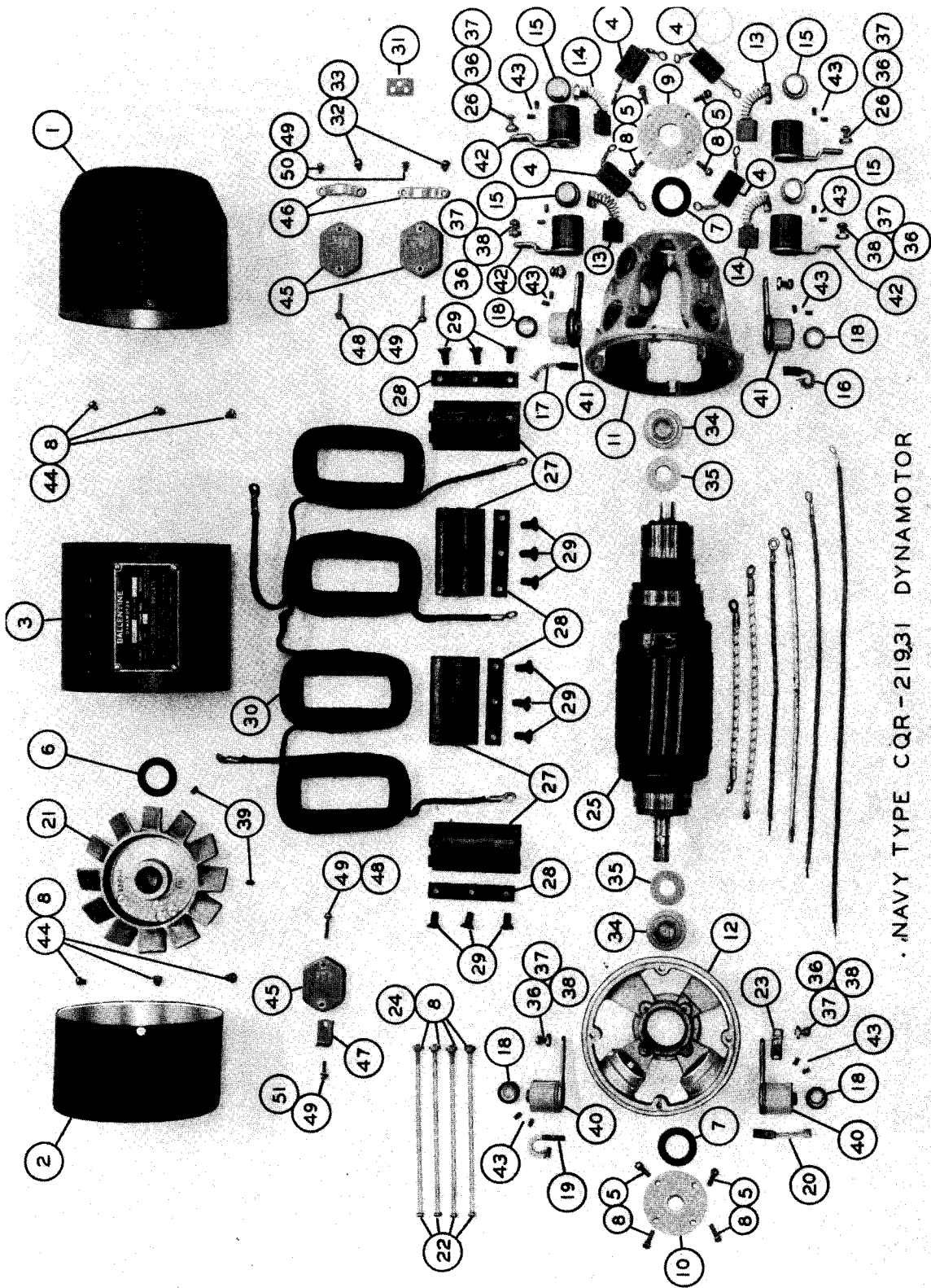

NAVY TYPE CQR-21931 DYNAMOTOR

Figure 5-33. Russell Type 502 D3 COA Dynamotor Parts



AN 08-30ART13-5

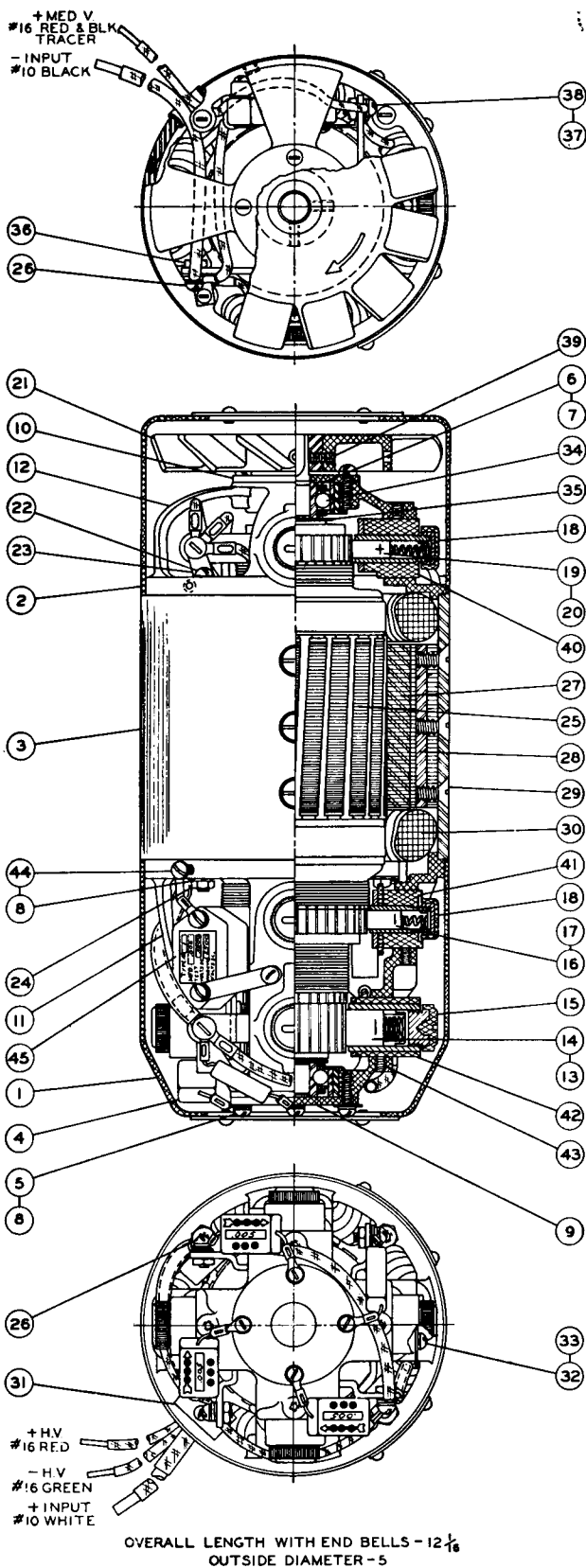
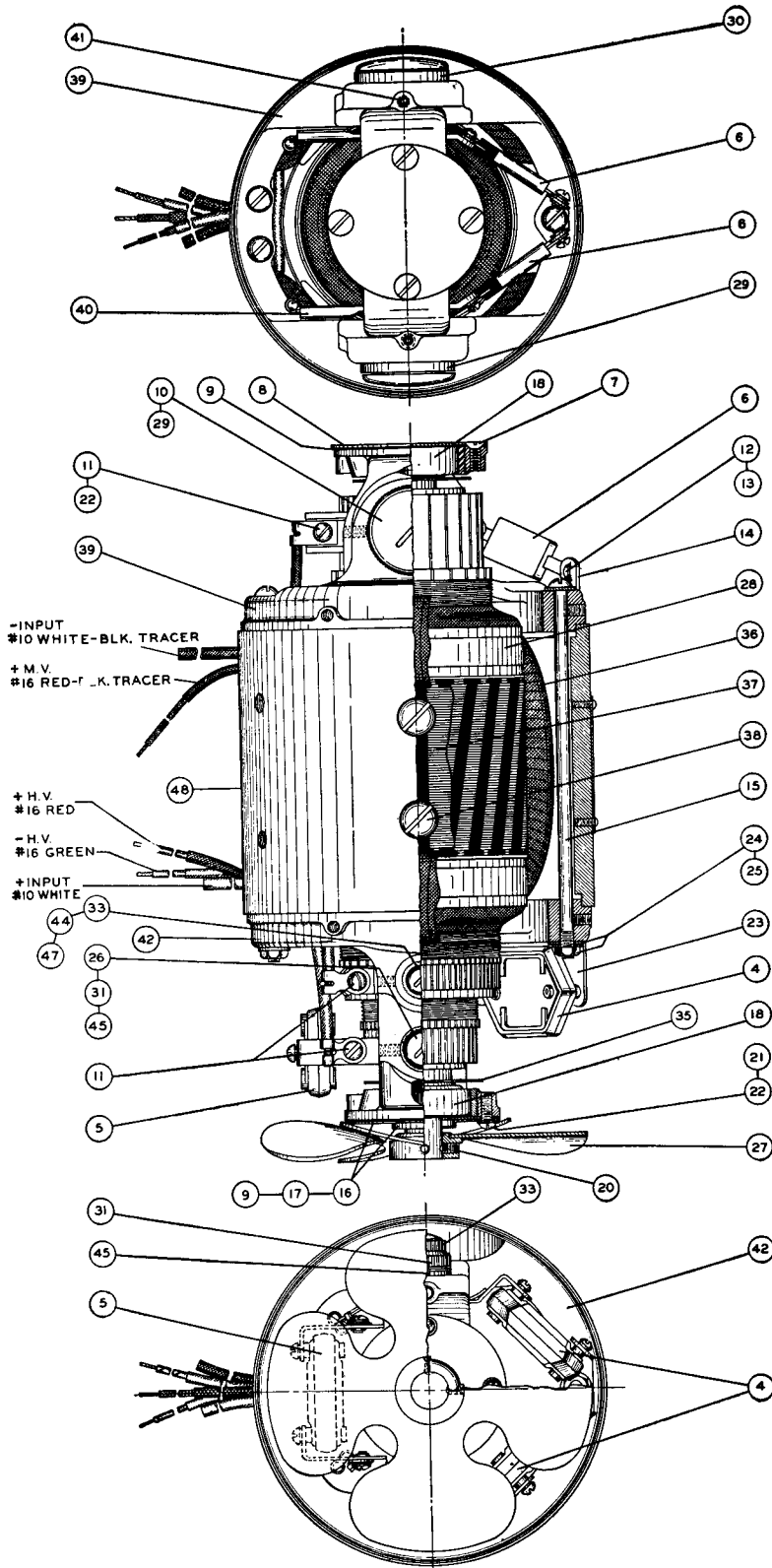

Figure 5-34. Russell Type 502 D3 COA Dynamotor

AN 08-30ART13-5



OVERALL LENGTH WITH END BELLS - 11.012  
OUTSIDE DIAMETER - 5.125

Figure 5-35. Wincharger Type 51S1 Dynamotor

p. PARTS LIST FOR TYPE DY-12/ART-13 DYNAMOTOR POWER UNIT DYNAMOTOR  
(Wincharger Type 51S1 Part No. 231 0004 00)

<u>Item</u>	<u>Symbol Designation</u>	<u>Quantity</u>	<u>Wincharger Part Number</u>	<u>Description</u>
1		1	B-6491	End Cover Assembly (Fan End)
2		6	6630	Number 8-32 x 1/2 Filister Head Machine Screw
3		6	6631	Number 8 Flat Washer 3/8 OD x .170 ID
4	C2109, C2110	2	A-6662	Capacitor .006 mf 5000 TV
5	C2108	1	A-6661	Capacitor .006 mf 2500 TV
6	C2106A, C2107A	2	A-6660	Capacitor .005 mf 1000 TV
7		4	5177	Number 8-32 x 3/8 Flat Head Machine Screw
8		1	A-6633	End Bracket Plate
9		2	A-6508	End Bracket Plate Gasket
10		2	A-6588	Brush Holder Cap
11		6	5992	Number 8-32 x 1/4 Binder Head Machine Screw
12		4	5124	Number 6-32 x 3/16 Binder Head Machine Screw
13		10	5357	Number 6 S. A. E. Standard Steel Lockwasher
14		1	A-6648	Clip for Capacitor (Input End)
15		3	A-6481	Through Bolt 10-32 x 5-7/16 Round Head
16		1	A-6635	End Bracket Plate
17		1	A-6636	Detainer Plate
18		2	6211	Armature Bearing
19		1	A-6818	3/32 Felt Washer
20		2	6414	Fan Set Screw Number 8-32 x 1/4 Hexagon Screw
21		4	6813	Number 8-32 x 3/8 Binder Head Steel Screw
22		10	5442	Number 8 S. A. E. Standard Steel Lock- washer
23		1	A-6648	Clip for Capacitor (HV End)
24		3	5415	Through Bolt Lockwasher Number 10 S. A. E. Standard
25		3	5722	Through Bolt Nut Number 10-32 Standard
26		2	A-5065	Brush Holder Cap
27		1	A-6788	Fan Assembly
28		1	B-6498	Armature & Bearing Assembly
29	E2101A	1	A-6555	Input Brush Assembly Positive
30	E2101B	1	A-6555-1	Input Brush Assembly Negative
31	E2101C	1	A-6556	LV Output Brush Assembly Positive
32	E2101D	1	A-6556-1	LV Output Brush Assembly Negative
33	E2101E	1	A-5742	HV Output Brush Assembly Positive
34	E2101F	1	A-5742-1	HV Output Brush Assembly Negative
35		2	A-6639	Oil Slings
36		1	B-6675	Field Coil Assembly
37		2	A-6479	Pole Shoe Assembly
38		4	5724	1/4-28 x 11/16 Flat Head Machine Screw
39		1	B-6468	Input End Bracket

Section V  
Paragraph 10

AN 08-30ART13-5

PARTS LIST FOR TYPE DY-12/ART-13 DYNAMOTOR POWER UNIT DYNAMOTOR (Continued)  
(Wincharger Type 51S1 Part No. 231 0004 00)

<u>Item</u>	<u>Symbol Designation</u>	<u>Quantity</u>	<u>Wincharger Part Number</u>	<u>Description</u>
40		2	A-6485	Brush Holder, Lug, and Insulation Assembly Input End
41		4	6616	Number 8-32 x 3/16 Bristo Set Screw
42		1	B-6469	HV End Bracket
43		1	A-6673	Brush Holder & Insulation Assembly Negative Input
44		2	A-6489	Brush Holder & Insulation Assembly HV
45		1	A-6487	Brush Holder & Lug Assembly Positive Input
46		1	B-6490	End Cover Assembly (Opposite Fan End)
47		2	A-5125	Brush Holder Cap
48		1	B-6492	Field Shell Assembly
—		6	6616	Number 8-32 x 3/16 Bristo Set Screw
—		2	6798	Number 8-32 x 1/8 Bristo Set Screw

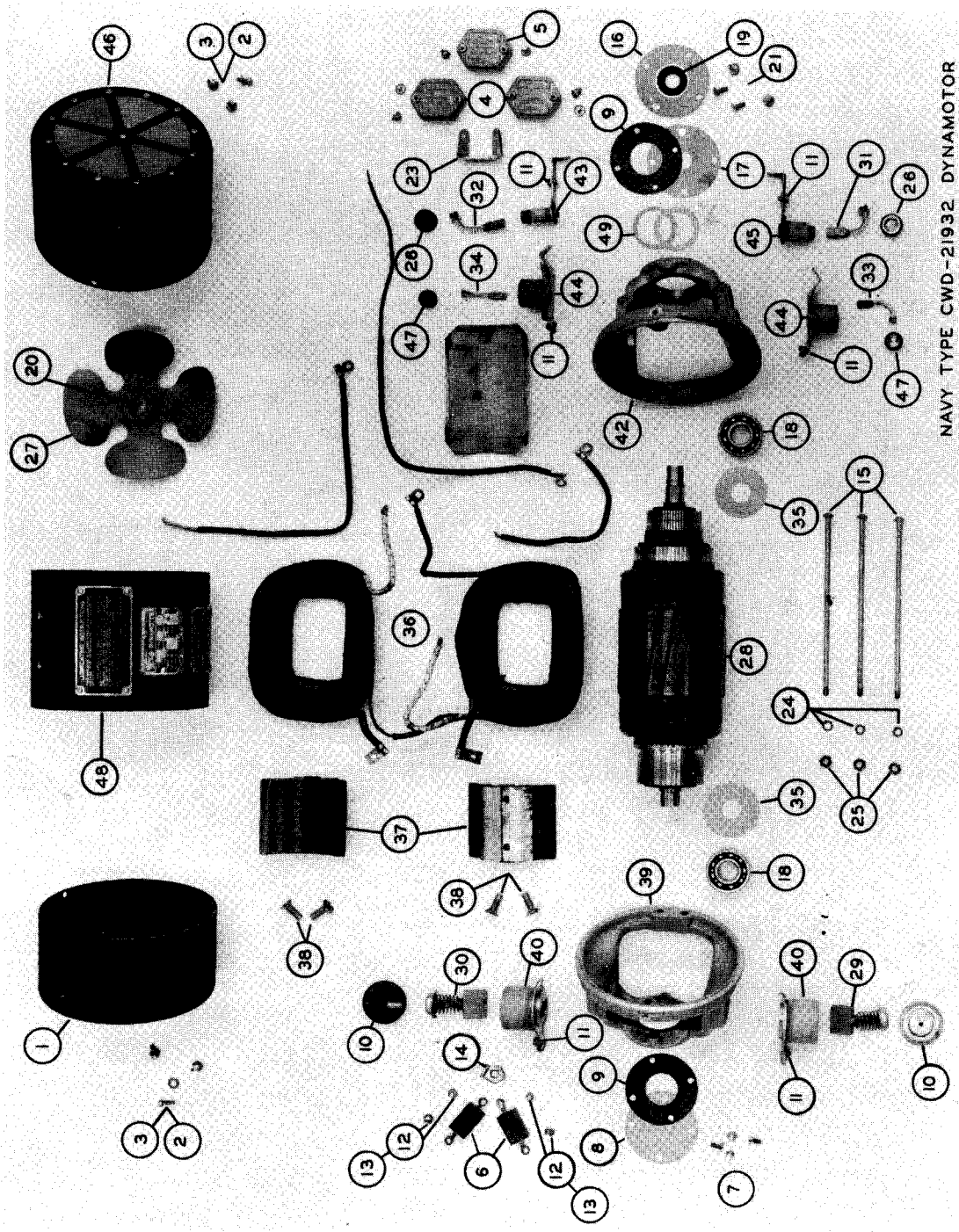

Figure 5-36. Wincharger Type 51S1 Dynamotor Parts

Section V  
Paragraph 10

AN 08-30ART13-5

g. PARTS LIST FOR TYPE DY- /ART-13 DYNAMOTOR POWER UNIT DYNAMOTOR  
(Fractional Type D-100 Part No. 231 0008 00)

Item	Symbol Designation	Quantity	Fractional Part Number	Description
1		1	ARP-101	Armature Assembly
2		2	BHC-102	Brush Holder Cap
3		4	BHC-103	Brush Holder Cap
4		2	BI-101	Brush Holder Insulator
5		2	BLT-101	Brush Holder Assembly
6		1	BLT-102L	Brush Holder Assembly
7		1	BLT-102R	Brush Holder Assembly
8		2	BLT-103	Brush Holder Assembly
9	E2701C, E2701D	2	BR-102	Brush
10	E2701E, E2701F	2	BR-103	Brush
11	E2701A, E2701B	2	BR-111	Brush
12		1	CB-101	Capacitor Bracket
13	C2708	1	CD-101	Capacitor
14	C2709, C2710	2	CD-102	Capacitor
15	C2706, C2707	1	CD-103S	Capacitor Assembly
16		1	COF-125	Coil Assembly
17		1	DB-101	End Bracket
18		1	DB-102	End Bracket
19		2	DPL-102S	Pole Piece Assembly
20		1	DY-101	Yoke
21		1	E-101	End Plate
22		1	E-102	End Plate
23		1	EC-101	End Cap
24		1	EC-102	End Cap
25		2	FG-101	Fibre Grommet
26		1	FN-101	Fan
27		2	HN-101	Hexagon Nut 10-32
28		4	HN-102	Hexagon Nut 6-32
29		(as required)	IWA-120	End Play Washer
30		(as required)	IWA-121	End Play Washer
31		(as required)	IWA-122	End Play Washer
32		2	LK-101	Lamination Key
33		1	LWR-101	Lead Wire Retainer
34		1	N-101	Nameplate
35		8	R-103	Rivet
36		2	SCN-101	Screen
37		12	SCR-101	Set Screw 10-32 x 1/4 Allen Head (Steel)
38		4	SCR-103	Screw 1/4-28 x 9/16 Flat Head (Steel)
39		6	SCR-104	Screw 8-36 x 1/4 Filister Head (Steel)
40		8	SCR-105	Screw 8-36 x 3/8 Flat Head (Steel)
41		8	SCR-106	Screw 8-36 x 3/4 Filister Head (Steel)
42		2	SCR-110	Screw 10-32 x 7/16 Binder Head (Brass)
43		2	SCR-111	Screw 6-32 x 1/2 Binder Head (Brass)
44		4	SCR-112	Screw 6-32 x 3/4 Round Head (Steel)
45		4	SCR-222	Screw Drive Screw Number 4 x 3/16 Type "U" (Steel)
46		2	WA-104	Lock Washer
47			WA-106	Takeup Washer
48		6	WA-201	Lockwasher
49		4	WA-202	Washer
50		10	WA-205	Lockwasher

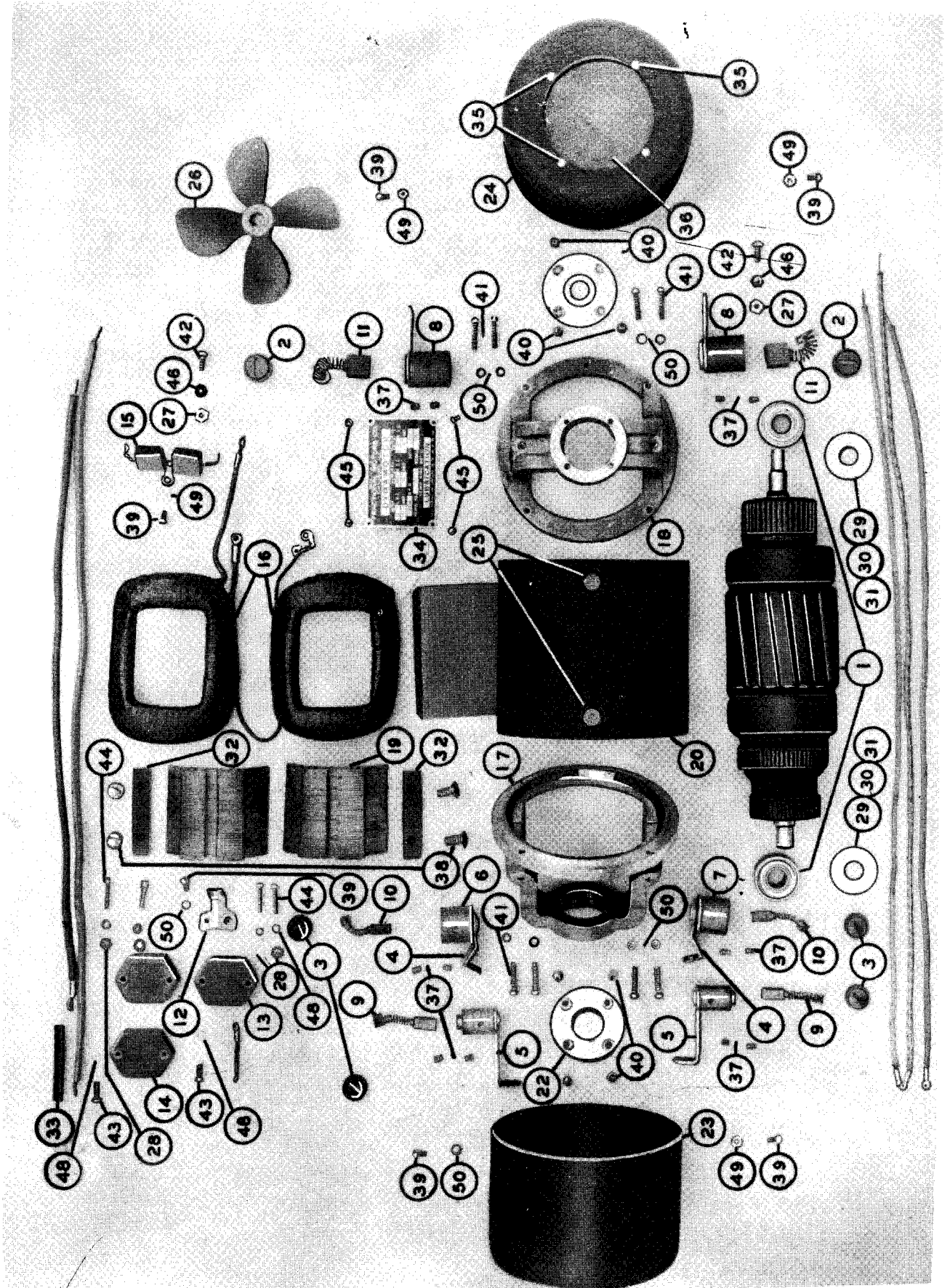

Figure 5-37. Fractional Type D-100 Dynamotor Parts

AN 08-30ART13-5

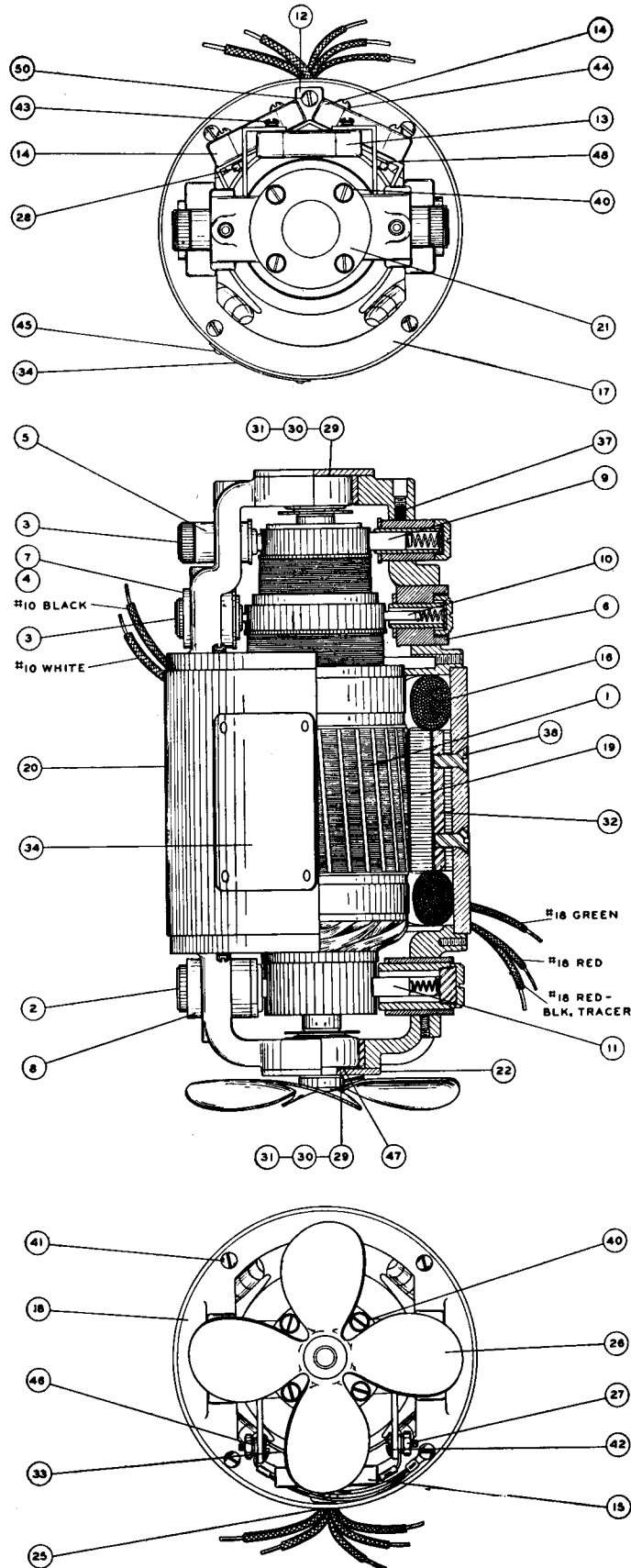

Figure 5-38. Fractional Type D-100 Dynamotor



SECTION VI  
SUPPLEMENTARY DATA

## 1. POWER INPUT REQUIREMENTS.

Type of Emission	Power Input	
	Full Power	Reduced Power
CW	770 watts	658 watts
CW (Stand-by)	505 watts	486 watts
MCW	855 watts	700 watts
MCW (Stand-by)	536 watts	510 watts
VOICE (No Modulation)	800 watts	672 watts
VOICE (90% Mod.)	896 watts	700 watts
VOICE (Stand-by)	235 watts	235 watts

**Note**

All of the above power input measurements were made with 28 volts dc input to the dynamotor and with power amplifier loaded to rated P.A. PLATE meter reading.

## 2. TYPICAL AUDIO-FREQUENCY DATA.

## a. OVERALL AUDIO-FREQUENCY RESPONSE (EITHER CARBON OR DYNAMIC INPUT).

Frequency	50% Mod.	90% Mod.
100 cps	-7.6 db	-7.0 db
200 cps	-3.4 db	-2.8 db
300 cps	-2.2 db	-1.7 db
500 cps	-0.7 db	-0.4 db
1000 cps	0.0 db	0.0 db
2000 cps	-0.2 db	-0.3 db
3000 cps	-0.7 db	-0.9 db
4000 cps	-1.6 db	-1.8 db
5000 cps	-2.7 db	-3.2 db

## b. AUDIO INPUT.

Input required for 90% Modulation at 1000 cps—

Reduced Power (750 v On Plates of PA and Modulator Tubes)—

CARBON Input: 1.13 v required

DYNAMIC Input: 11.7 mv required

Full Power (1160 v On Plates of PA and Modulator Tubes)—

CARBON Input: 1.52 v required

DYNAMIC Input: 16.0 mv required

## c. NOISE LEVEL.

Below 100% Modulation with input at 1000 cps—

Reduced Power (750 v On Plates of PA and Modulator Tubes)—

CARBON Input: -44 db

DYNAMIC Input: -43 db

Full Power (1160 v On Plates of PA and Modulator Tubes)—

CARBON Input: -44 db

DYNAMIC Input: -45 db

## d. AUDIO DISTORTION.

Distortion with 90% Modulation at 1000 cps—  
Reduced Power (750 v On Plates of PA and Modulator Tubes)—

CARBON Input: 3.8% Distortion

DYNAMIC Input: 3.8% Distortion

Full Power (1160 v On Plates of PA and Modulator Tubes)—

CARBON Input: 4.5% Distortion

DYNAMIC Input: 4.7% Distortion

## e. SIDETONE DISTORTION.

Distortion measured on output of SIDETONE at Position 5 with 90% Modulation at 1000 cps—  
Reduced Power (750 v On Plates of PA and Modulator Tubes)—

CARBON Input: 6.5% Distortion

DYNAMIC Input: 6.6% Distortion

Full Power (1160 v On Plates of PA and Modulator Tubes)—

CARBON Input: 8.8% Distortion

DYNAMIC Input: 8.9% Distortion

## f. SIDETONE OUTPUT:

Switch Position	Output		Load Impedance
	CW	MCW	
1	0.6 volt	0.75 volt	125 ohms
2	1.3 volt	1.6 volt	125 ohms
3	2.5 volts	3.0 volts	125 ohms
4	5.0 volts	6.0 volts	125 ohms
5	8.8 volts	10.5 volts	125 ohms
6	19.5 volts	23.5 volts	2000 ohms

**Note**

All of the above audio-frequency measurements were made with Control "A" in Position 2 at an RF output frequency of 3.0 MC, with 28 v dc input to the dynamotor and with power amplifier loaded to rated P.A. PLATE meter reading.

TABLE 6-1  
MCW-CFI UNIT OUTPUT LEVEL

DB at SIDETONE jack J104 of T-47/ART-13 Transmitter with MCW-CFI UNIT and Type O-16/ART-13 Low Frequency Oscillator installed.  
A 500 ohm 6 mw "Zero" Reference Type Meter across 125 ohms is employed.  
Sidetone OUTPUT Level switch on Position 5

Frequency	Dial "G"	db	Frequency	Dial "G"	db	Frequency	Dial "G"	db
200	Band 1		450	Band 3 (Continued)		850	Band 5 (Continued)	
225	393	9.5	466-2 3	1732	15	875	1079	9
250	936	Useable		1909	Useable	900	1199	6
	1159	Useable		Band 4		925	1316	
	1363	Useable				950	1433	4.5
	1729	14				975	1550	
	1959	Useable				1000	1670	7
	Band 2					1025	1797	
275	559	0	450	00	15		1939	
300	762	Useable	475	272.5	16		Band 6	
325	1114	15	500	522		1025	095	10-1/2
350	1418	Useable	525	742	13.5	1050	222	
	1557	1	550	942		1075	340	9
	1690	Useable	575	1127		1100	450	
	1941	16	600	1305	11	1125	555	9
	Band 3		625	1479		1150	654	
350	160	16	650	1656	11	1175	749	9
	532	Useable	675	1848	10	1200	841	9
375	688	3	700	2084		1225	929	8
400	832	Useable		Band 5		1250	1014	
	1091	15	675	00		1275	1097	6-1/2
	1322	Useable	700	199	15	1300	1179	6
433-1 3	1534	Useable	725	376		1325	1259	
			750	537	11	1350	1339	6
			775	685		1375	1417	6
			800	823	9	1400	1494	
			825	954		1450	1658	3-1/2
						1500	1832	

TABLE 6-1 (Continued)

Frequency	Dial "B"	db
kc 2000	100	+10
2023	223	Useable
2050	284	Useable
2066-2/3	346	+10.5
2100	469	Useable
2133-1/3	591	Useable
2150	655	Useable
2166-2/3	717	Useable
2200	841	+9
2233-1/3	965	Useable
2250	1026	Useable
2267	1087	Useable
2300	1209	+8.5
2333-1/3	1332	Useable
2350	1393	Useable

Frequency	Dial "B"	db
kc 2366-2/3	1455	Useable
2400	1578	+9
	1704	Useable
	1767	Useable
	1832	Useable
2500	1967	+8
2400	60	+10
2433-1/3	162	Useable
2450	213	Useable
2466-2/3	263	Useable
2500	365.5	+9.5
2533-1/3	468	Useable
2550	518	Useable
2566-2/3	570	Useable
2600	673	+7.0

Frequency	Dial "B"	db
kc 2633-1/3	775	Useable
2650	826	Useable
2666-2/3	878	Useable
2700	979	+6.5
2733-1/3	1081	Useable
2750	1132	Useable
2766-2/3	1183	Not Good
2800	1284	+6.5
2833-1/3	1385	Useable
2850	1436	Useable
2900	1589	+5.5
2933-1/3	1694	Useable
2950	1746	Useable
3000	1910	+4

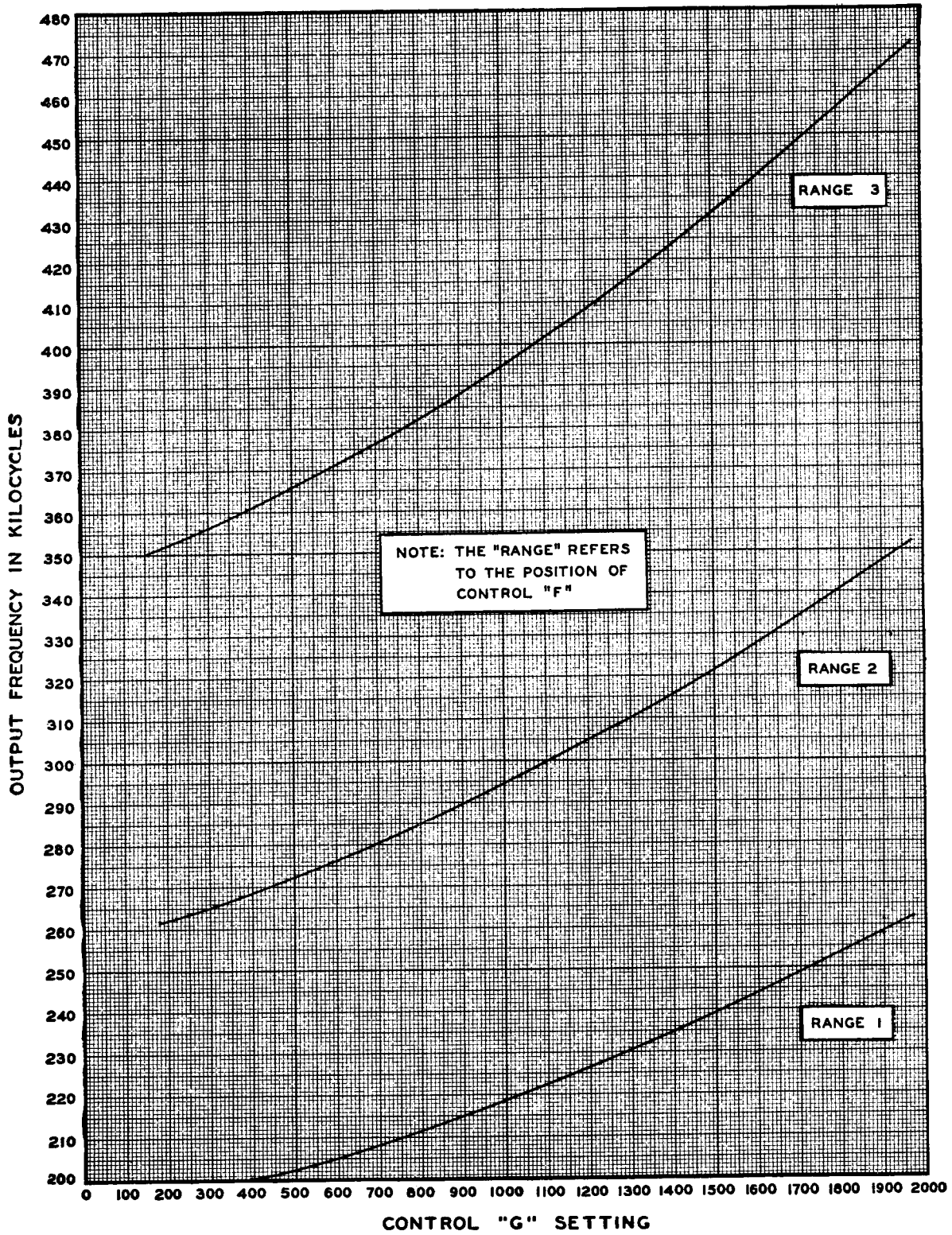

Figure 6-1. Low Frequency Tuning Chart (Sheet 1 of 2 Sheets)  
200 kc to 475 kc

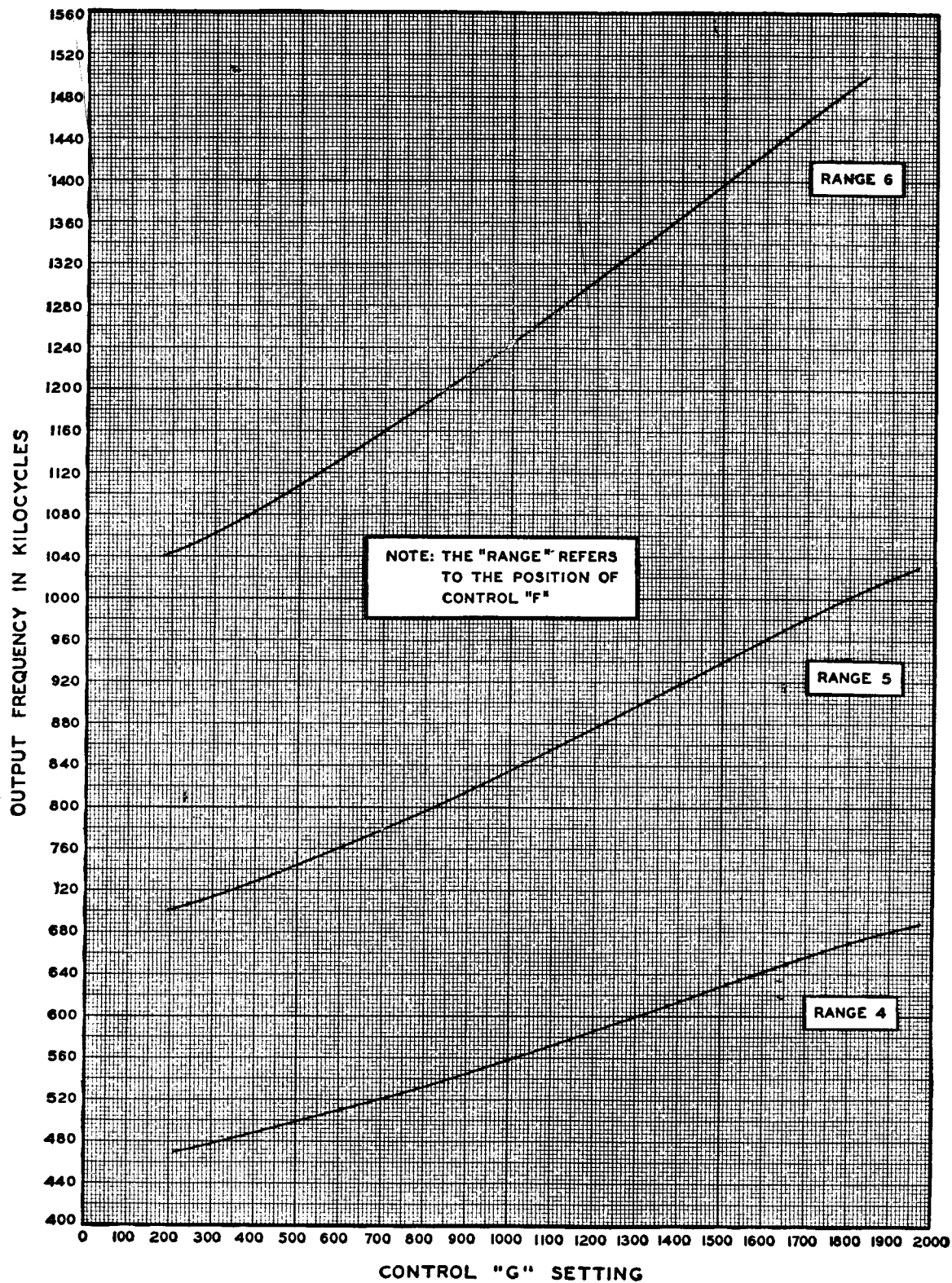

Figure 6-1. Low Frequency Tuning Chart (Sheet 2 of 2 Sheets)  
475 kc to 1500 kc

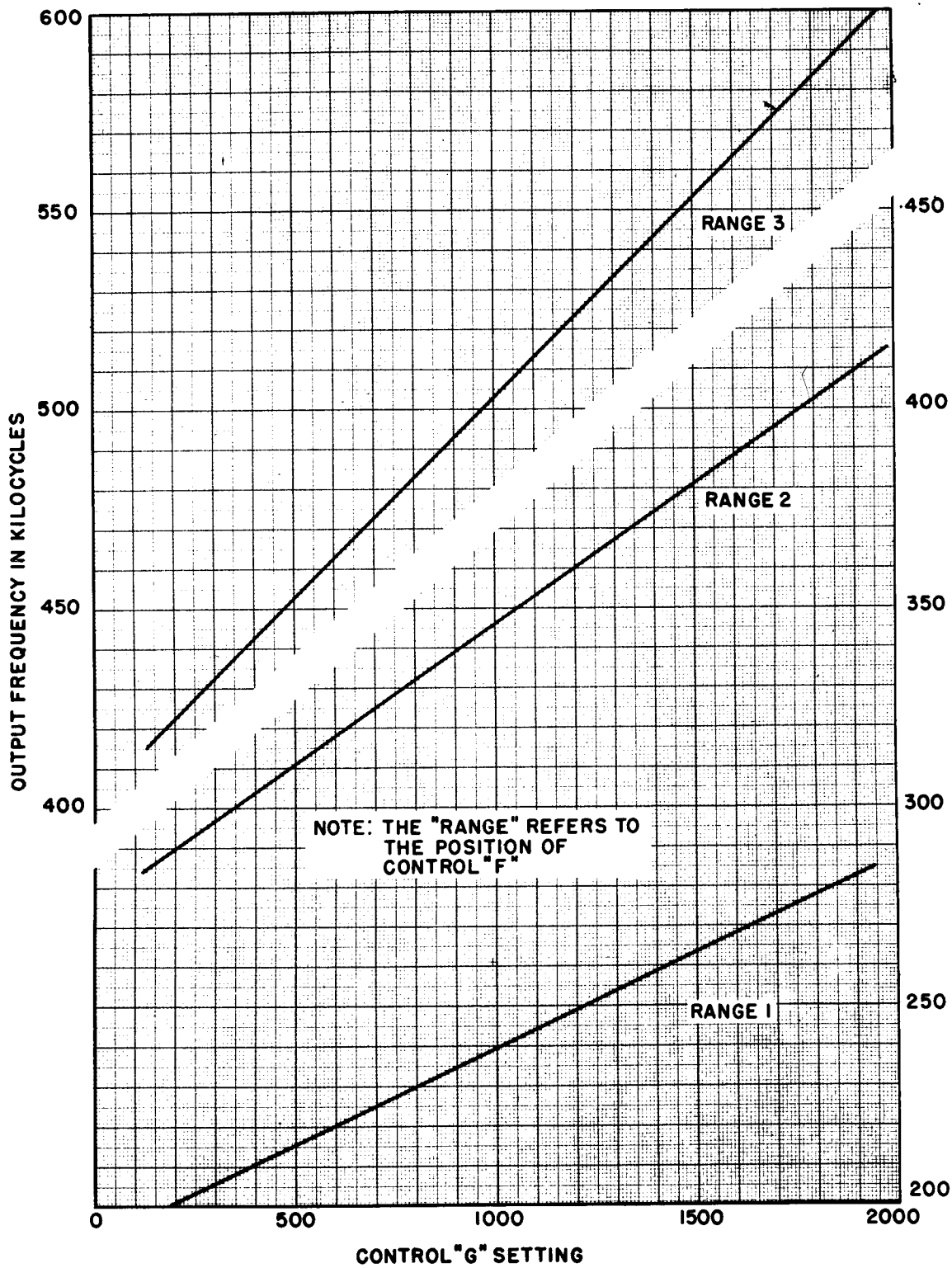

Figure 6-1A. Low Frequency Tuning Chart for O-17/ART-13A 200kc to 600kc

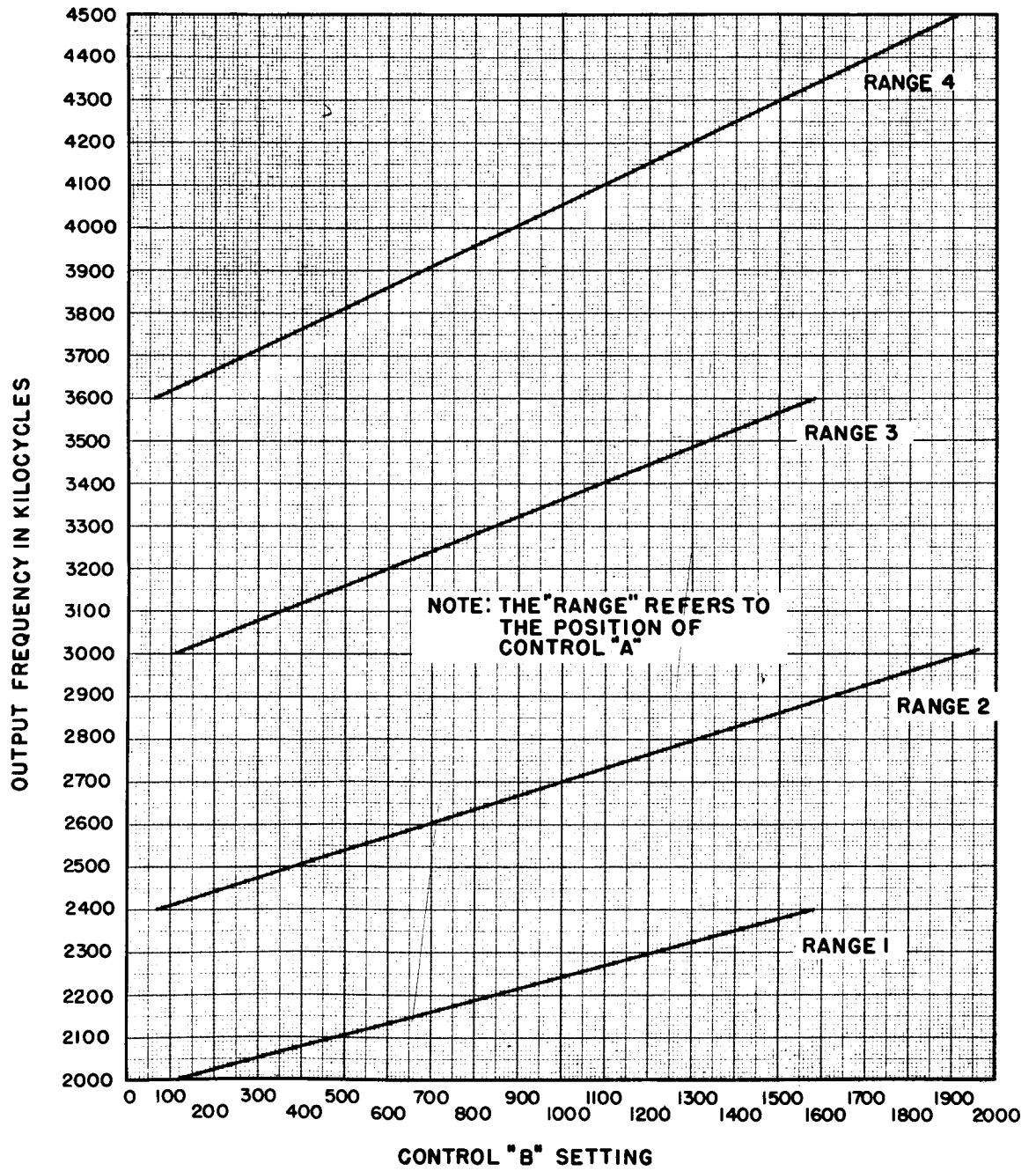

Figure 6-2. High Frequency Tuning Chart (Sheet 1 of 3 Sheets)  
2000kc to 4000kc

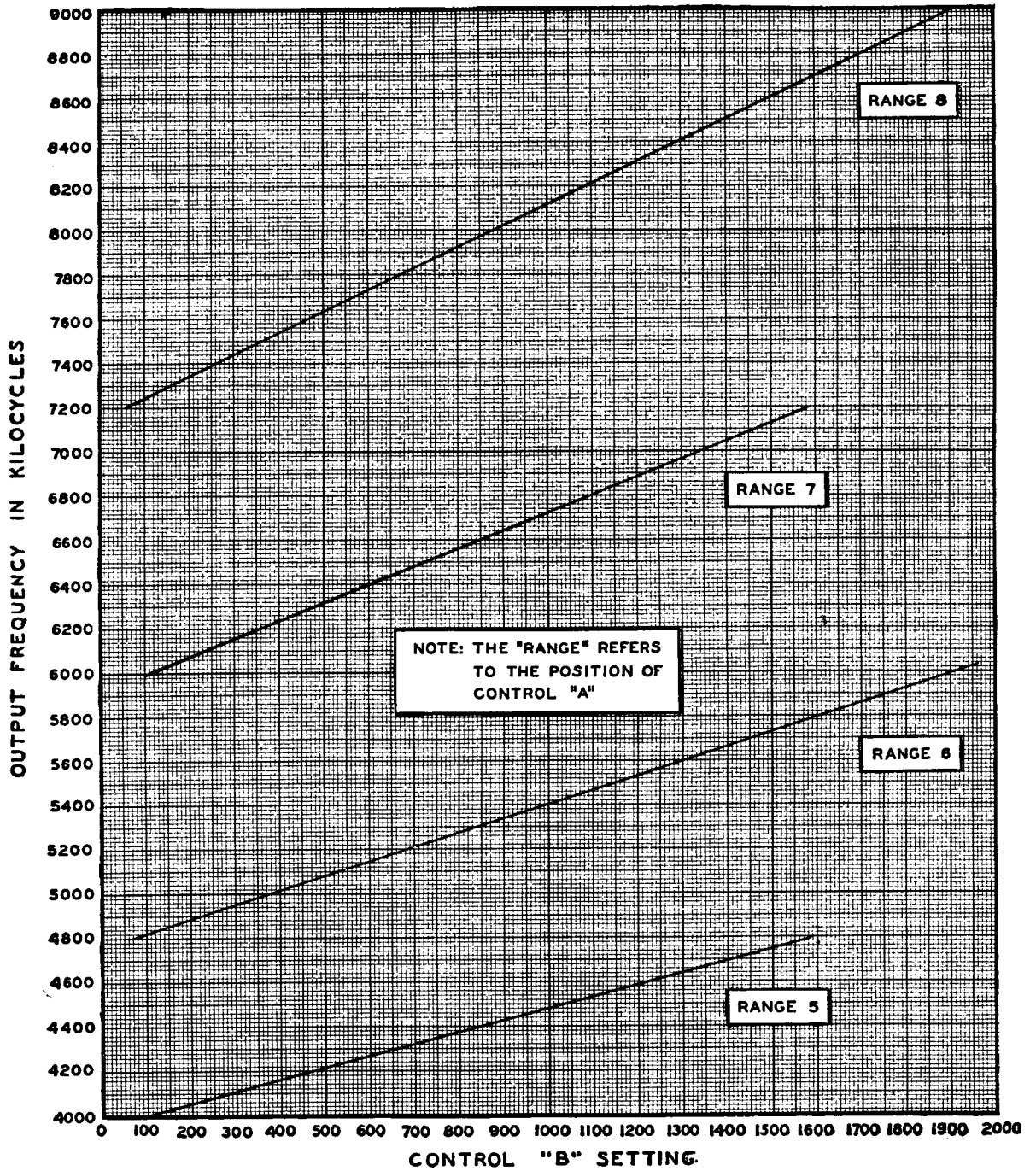

Figure 6-2. High Frequency Tuning Chart (Sheet 2 of 3 Sheets)  
4000 kc to 9000 kc



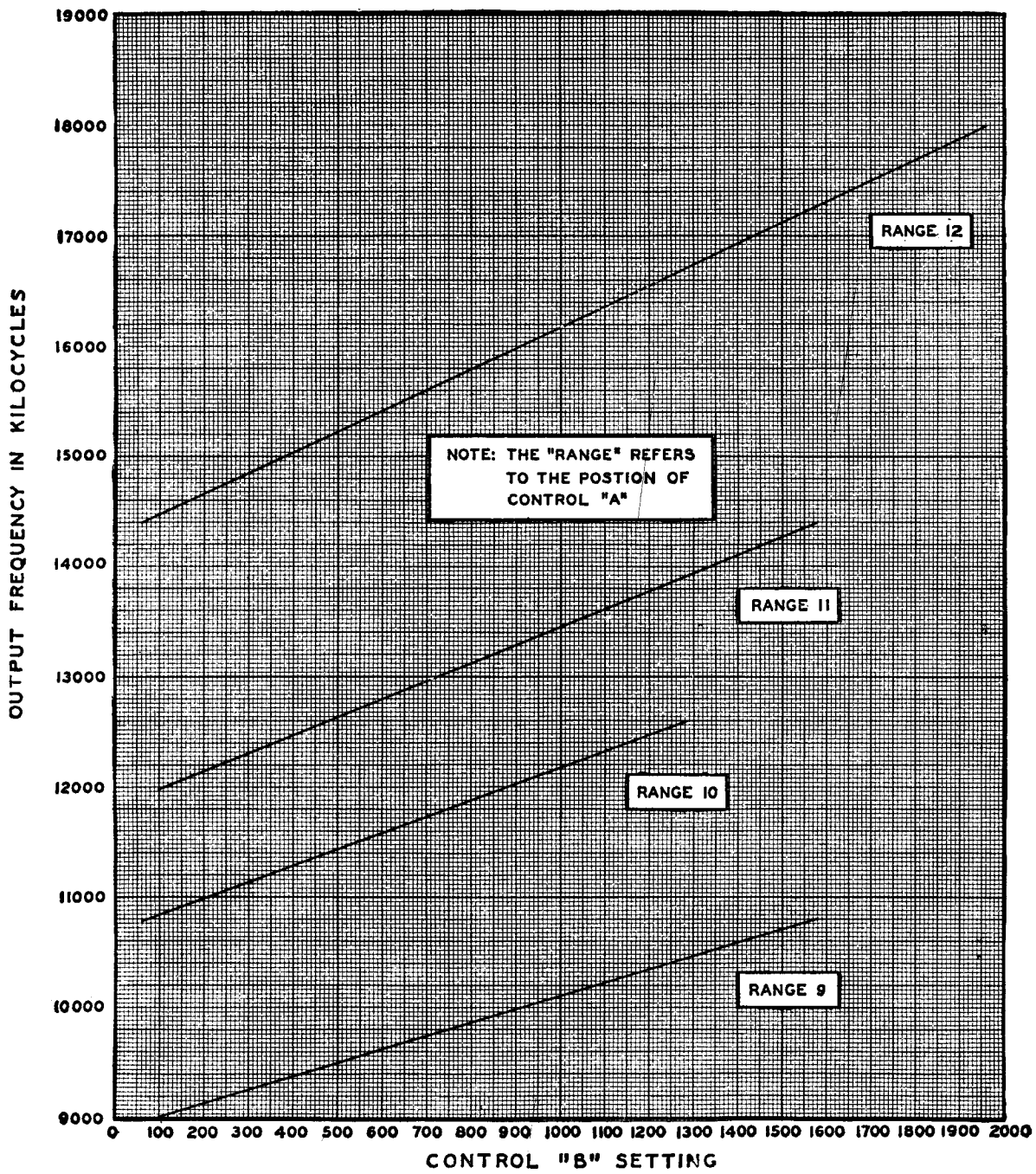

Figure 6-2. High Frequency Tuning Chart (Sheet 3 of 3 Sheets)  
9000 kc to 18,000 kc

### 3. RESISTANCE MEASUREMENTS ON ROTATING MACHINES.

All resistance readings were made with all brushes removed from the machines.

#### a. AUTOTUNE MOTOR.

(1) Emerson Type NY-818C-A direct current shunt wound motor 3.1 amps, 28 volts,  $\frac{1}{20}$  hp, 3900 rpm. Part No. 508 0818 31. Refer to figure 6-3.

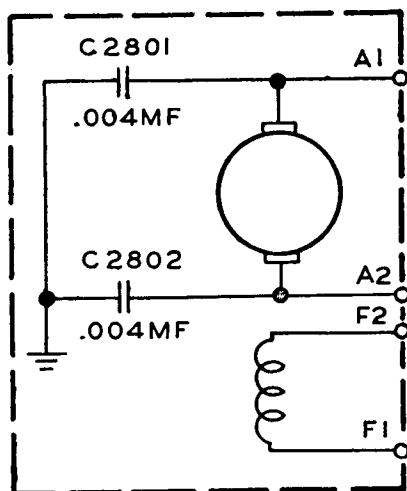

NY818C-A  
AUTOTUNE MOTOR

Figure 6-3. Emerson Type NY-818C-A  
Motor Schematic

(a) Resistance between commutator segments diametrically opposed = 1.26 ohms.

(b) Resistance between adjacent commutator segments = 0.3 ohms (22 commutator segments).

(c) Field resistance, F1 to F2 = 17.8 ohms.

(2) Ohio Type NY-818C-B direct current shunt wound motor 4.2 amps, 28 volts,  $\frac{1}{20}$  hp, 3600 rpm. Part No. 508 0818 32. Refer to figure 6-4.

(a) Resistance between commutator segments diametrically opposed = 4.5 ohms.

(b) Resistance between adjacent commutator segments = 1 ohm (21 commutator segments).

(c) Field resistance, F1 to F2 = 27.5 ohms.

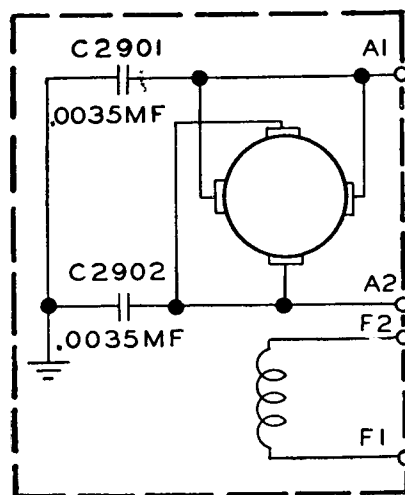

NY818C-B  
AUTOTUNE MOTOR

Figure 6-4. Ohio Type NY-818C-B  
Motor Schematic

(3) Fractional Type NY-818C-C direct current shunt wound motor 3.1 amps, 28 volts,  $\frac{1}{20}$  hp, 3900 rpm. Part No. 508,0818 33. Refer to figure 6-5.

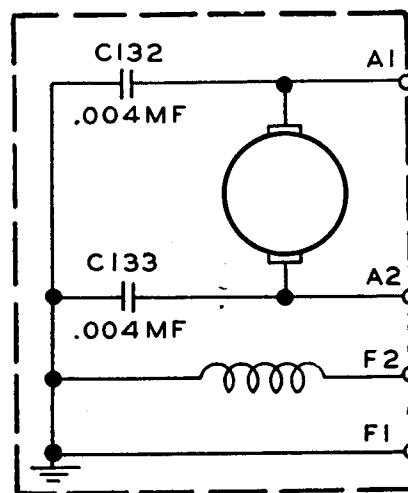

NY818C-C  
AUTOTUNE MOTOR

Figure 6-5. Fractional Type NY-818C-C  
Motor Schematic

(a) Resistance between commutator segments diametrically opposed = .83 ohms.

(b) Resistance between adjacent commu-

tator segments = .16 ohms (24 commutator segments).

(c) Field resistance, F1 to F2 = 27.0 ohms (F1 grounded to motor frame).

**Notes**

A short or low resistance to ground from either of terminal A1 or A2, with brushes removed and external wires disconnected, indicates a defective capacitor or brush holder.

A variation in resistance between adjacent commutator segments, with brushes removed indicates a defective armature.

A low resistance or short to ground from the commutator, indicates a defective armature.

A large discrepancy in field resistance or a short from F2 to ground indicates a defective field winding.

**b. HIGH VOLTAGE DYNAMOTOR.**

Input: 27 v dc at 32 amps; Output: 400 v dc at 0.75 amp, 750 v dc at 0.35 amp.

(1) Russell Type 502 D3 COA. Part No. 231 0003 00. Refer to figure 6-6.

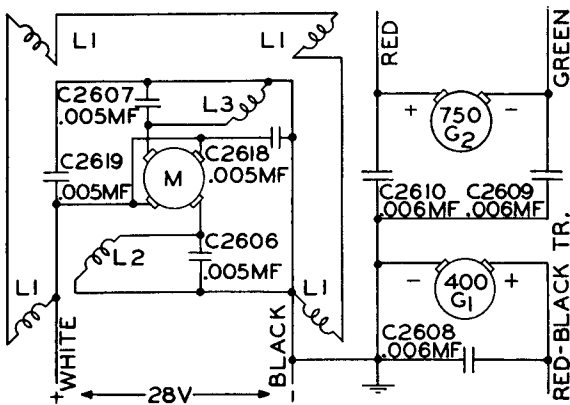

**Figure 6-6. Russell Type 502 D3 COA Dynamotor Schematic**

(a) Resistance from any one of the red, green or red-black wires to ground = infinity ohms.

(b) Average resistance between adjacent commutator segments on the 28 volt input with brushes removed = 0.019 ohm.

(c) Average resistance between adjacent commutator segments on the 400 volt output with brushes removed = 3.2 ohms.

(d) Average resistance between adjacent commutator segments on the 750 volt output with brushes removed = 5.95 ohms.

(e) The shunt field resistance (L1, four windings in series) measured between the White and Black wires = 36.0 ohms.

(f) The series field windings L2 and L3 = Approx. 0.002 ohm each.

(2) Wincharger Type 51S1.

Part No. 231 0004 00. Refer to figure 6-7.

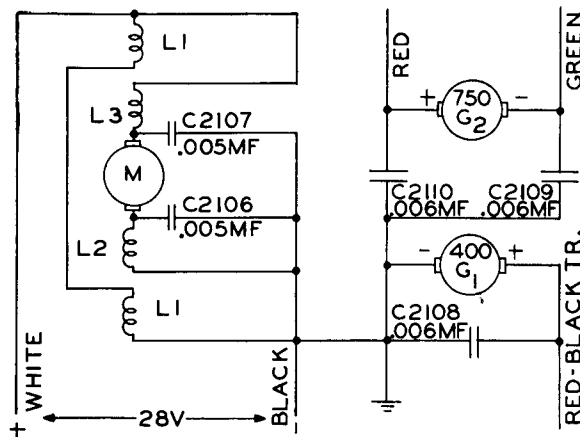

**Figure 6-7. Wincharger Type 51S1 Dynamotor Schematic**

(a) Resistance from any one of the red, green or red-black wires to ground = infinity ohms.

(b) Resistance between adjacent bars on 28 volt winding = .005 ohms.

(c) Resistance between diametrically opposed segments on 28 volt winding = .025 ohms.

(d) Resistance between adjacent commutator bars on 400 volt winding = 1.34 ohms.

(e) Resistance between adjacent commutator bars on 750 volt winding = 6.8 ohms.

(f) Shunt field resistance (L1, two windings in series) measured between White and Black wires = 30 ohms.

(g) Series field resistance (windings L2 and L3) = less than .001 ohm each.

- (3) Fractional Type D-100.  
Part No. 231 0008 00. Refer to figure 6-8.

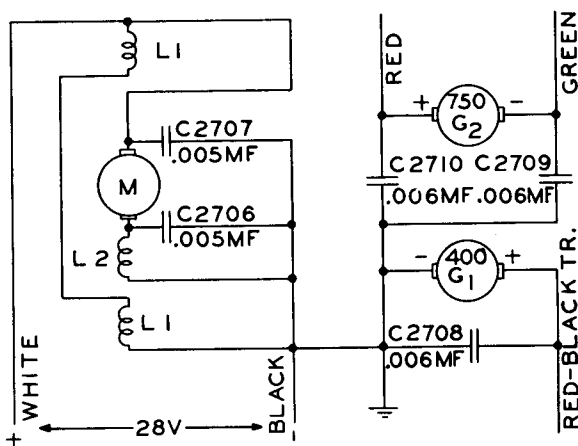

Figure 6-8. Fractional Type D-100  
Dynamotor Schematic

(a) Resistance from any one of the red, green or red-black wires to ground = infinity ohms.

(b) Average resistance between adjacent commutator segments on the 28 volt input with brushes removed = .02 ohms.

(c) Average resistance between adjacent commutator segments on the 400 volt output with brushes removed = 2.1 ohms.

(d) Average resistance between adjacent commutator segments on the 750 volt output with brushes removed = 4.4 ohms.

(e) The shunt field resistance (L1, two windings in series) measured between White and Black wires = 47.0 ohms.

(f) Series field resistance (winding L2) = Approximately .003 ohms each.

**Notes**

A low resistance or short to ground from the red, green or red-black wires, with brushes removed, indicates a defective capacitor or brush holder.

A variation in resistance between adjacent segments on any commutator, with brushes removed, indicates a defective armature.

A low resistance or short to ground from any commutator, with brushes removed, indicates a defective armature.

A large discrepancy in shunt field resist-

ance indicates a defective or shorted field winding.

**4. APPLICABLE COLOR CODES.**

a. RADIO MANUFACTURERS ASSOCIATION CODES.

(1) MOLDED CASE MICA DIELECTRIC CAPACITOR COLOR CODES.

(a) The most generally used in this equipment is one incorporating four dots of different colors corresponding to the Standard RMA color coding as listed below:

Capacity Code	Ciphers	
0—Black	Black	None
1—Brown	Brown	0
2—Red	Red	00
3—Orange	Orange	000
4—Yellow	Yellow	0000
5—Green	Green	00000
6—Blue	Blue	000000
7—Violet	Violet	0000000
8—Gray	Gray	00000000
9—White	White	000000000

(b) The capacity value is indicated in the micromicrofarads and is determined by the sequence of the dots. The first dot in the upper left-hand corner of the capacitor is the first number and the second dot is the second number. The third dot indicates the number of ciphers to be used with the first two numbers. The fourth dot located in the lower right-hand corner or on the edge of the capacitor indicates the capacity tolerance.

(c) The tolerance color code is as follows:

1% Brown	6% Blue
2% Red	7% Violet
3% Orange	8% Gray
4% Yellow	9% White
5% Gold or Green	10% Silver

(d) The capacitor shown in the following example has a capacity of 250 mmf (0.00025 mf). The color sequence is red (2), green (5), and

brown (1). The tolerance is  $\pm 5\%$ , as indicated by the green spot in the lower right-hand corner or on the edge.

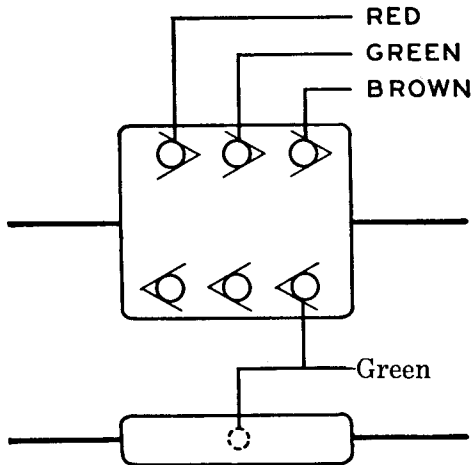

Figure 6-9. RMA Capacitor Color Code Example—  
Four Dot

(e) A second capacitor color coding system is the Standard RMA system. In operation it is similar to the first system except that it uses six dots to indicate three numbers, multiplier tolerance and voltage rating.

(f) An example of this system is illustrated below:

(g) This being a 1250 mmf (0.00125 mf)

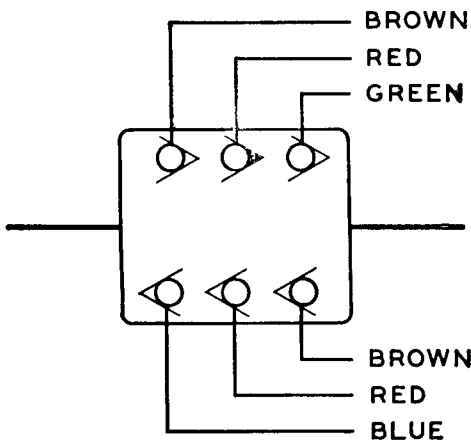

Figure 6-10. RMA Capacitor Color Code Example—  
Six Dot

600 volt capacitor with a  $\pm 2\%$  tolerance. The first three dots being the first three numbers and, continuing in a clockwise rotation, the fourth dot is the number of ciphers, the fifth tolerance, and the sixth the voltage rating.

The voltage ratings are:

Brown	— 100 volts
Red	— 200 volts
Orange	— 300 volts
Yellow	— 400 volts
Green or no color	— 500 volts
Blue	— 600 volts
Violet	— 700 volts
Gray	— 800 volts
White	— 900 volts
Gold	— 1000 volts
Silver	— 2000 volts

(2) CERAMIC CAPACITOR COLOR CODE.

—Characteristics of ceramic capacitors are determined from the following instructions and table:

(a) The temperature coefficient of capacitance is indicated by the color appearing on that end of the capacitor which provides termination for the inside plate or electrode. This color covers the entire end.

(b) The next three dots or bands of color indicate the capacity in micromicrofarads.

(c) The first dot or band immediately adjacent to the end color indicates the first significant figure of the capacity.

(d) The second and next adjacent color dot or band indicates the second significant figure of the capacity.

(e) The third and next adjacent color dot or band indicates the multiplier appropriate to the capacitor in mmf.

(f) The fourth and last adjacent color dot or band indicates the capacitance tolerance either in percent, in the case of capacitors of nominal capacitance in excess of 10 mmf, or in mmf, in case of capacitors of nominal capacitance of 10 mmf or less.

Tolerance Values

Color	Significant Figures	Multiplier	Capacitance More than 10 mmf	Capacitance 10 mmf or less	TEMPERATURE COEFFICIENT in mmf/mm <sup>2</sup> /C°
Black	0	1	±20%	±2.0 mmf	Zero ±.00003
Brown	1	10	±1%	±0.1 mmf	— .00003
Red	2	100	±2%	±0.2 mmf	— .00008
Orange	3	1000	±3%	±0.3 mmf	— .00015
Yellow	4	10,000	±4%	±0.4 mmf	— .00022
Green	5	—	±5%	±0.5 mmf	— .00033
Blue	6	—	±6%	±0.6 mmf	— .00047
Violet	7	0.001	±7%	±0.7 mmf	— .00075
Gray	8	0.01	±2.5%	±0.25 mmf	
White	9	0.1	±10%	±1.0 mmf	

(3) RESISTOR COLOR CODE.

(a) The standard RMA Color Code is used to indicate the resistance of the small resistors used in the equipment. The colors and corresponding numbers are listed as follows:

- 0.1—Gold    2—Red    5—Green    8—Gray  
 0—Black    3—Orange    6—Blue    9—White  
 1—Brown    4—Yellow    7—Violet

(b) The resistors are marked with three color "bands" near one end. All resistance values are in ohms. The color sequence begins with the color nearest the end of the resistor. The first "band" indicates the first number of the sequence, the second "band" the second number, and the third "band" the number of ciphers.

(c) Tolerance values for the resistors are designated by the fourth "band" on the resistor body using the following colors to indicate the percentage of tolerance:

- 1% Brown                      6% Blue  
 2% Red                         7% Violet  
 3% Orange                     8% Gray  
 4% Yellow                      9% White  
 5% Gold or Green          10% Silver

(d) For example, the resistor below has a resistance of 10,000 ohms and a tolerance of ±5%. Brown (1), black (0), orange (3), and gold (5).

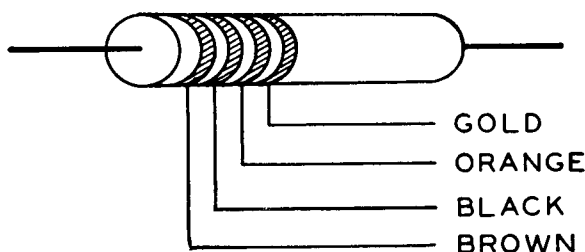
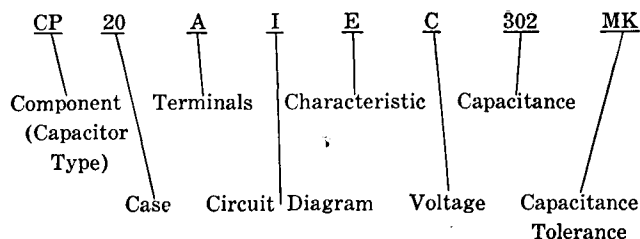

Figure 6-11. RMA Resistor Code Example

b. AMERICAN STANDARDS ASSOCIATION CODES.

(1) FIXED PAPER DIELECTRIC CAPACITORS.

(a) TYPE DESIGNATION.



(b) The nominal capacitance value is identified by three digits. The first two digits are the first two digits of the capacitance value in micro-microfarads. The third digit indicates the number of zeros which follow.

(c) The capacity tolerance in per cent is identified by two letters as indicated in the following table:

Designation Letters	Capacitance Tolerance in Per cent
KK	+10, —10
LL	+15, —15
MK	+20, —10
MM	+20, —20
NA	+25, — 0
PL	+40, —15
RN	+60, —25

(d) The nominal direct-voltage rating at

**Section VI**  
**Paragraph 4**

**AN 08-30ART13-5**

+40°C (+104°F) ambient temperature is identified by a single letter as indicated in the following table:

Designation Letter	Nominal Direct-Voltage Rating at +40°C (+104°F)
C	200
D	250
E	400
F	600
G	1000
H	1500
J	2000
K	2500
L	3000
M	4000
N	5000
P	6000
R	7500
S	10000
T	12500

**Note**

The significance of the letters denoting "Characteristic" will be found in the joint Army-Navy specification JAN-C-5. Information under the heading of "Characteristic" includes Q, dissipation factor, temperature coefficient and capacitance drift.

(2) **FIXED MICA-DIELECTRIC CAPACITORS.**

(a) **TYPE DESIGNATION.**

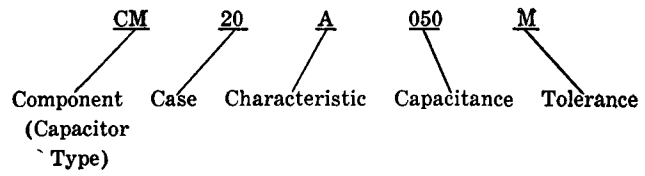

**ASA FIXED MICA-DIELECTRIC CAPACITOR**

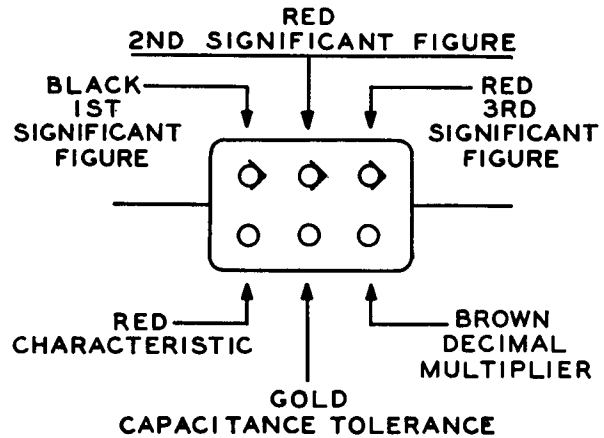

**EXAMPLE: 200 MMF ± 5% "C" CHARACTERISTIC**

**Figure 6-12. ASA Fixed Mica-Dielectric Capacitor Color Code**

(b) **COLOR CODING.** (Refer to figure 6-12.)

Color	Capacitance		Tolerance Percent	Characteristic
	Significant Figure	Decimal Multiplier		
Black	0	1	20 (M)	A
Brown	1	10		B
Red	2	100	2 (G)	C
Orange	3	1,000		D
Yellow	4			E
Green	5			F
Blue	6			G
Violet	7			
Gray	8			
White	9			
Gold		0.1	5 (J)	
Silver		.01	10 (K)	

AN 08-30ART13-5

(c) LETTER DESIGNATION FOR CHARACTERISTIC.

Characteristic	Temperature Coefficient Parts/Million	Capacitance Drift (max.)
	Degrees C.	
A	Not specified	Not specified
B	Not specified	Not specified
C	-200 to +200	±0.5 percent
D	-100 to +100	±0.3 percent
E	-20 to +100	±(0.1 percent +0.1 mmf)
F	0 to +70	±(0.05 percent +0.1 mmf)
G	0 to -50	±(0.05 percent +0.1 mmf)

(d) VOLTAGE RATING.

Cap MMF	WV	Case Size Overall
5 to 510 inc.	500	5 <sup>1</sup> / <sub>64</sub> " x 1 <sup>5</sup> / <sub>32</sub> " x 7 <sup>1</sup> / <sub>32</sub> " maximum
5 to 1000 inc.	500	1 <sup>1</sup> / <sub>6</sub> " x 1 <sup>5</sup> / <sub>32</sub> " x 7 <sup>1</sup> / <sub>32</sub> " maximum
470 to 3300 inc.	500	5 <sup>3</sup> / <sub>64</sub> " sq. x 1 <sup>1</sup> / <sub>32</sub> " maximum
470 to 5600 inc.	500	5 <sup>3</sup> / <sub>64</sub> " sq. x 1 <sup>1</sup> / <sub>32</sub> " maximum
6800 to 10000 inc.	300	300
3300 to 8200 inc.	500	1 <sup>1</sup> / <sub>32</sub> " x 4 <sup>1</sup> / <sub>64</sub> " x 1 <sup>1</sup> / <sub>32</sub> " maximum
9100 to 10000 inc.	300	300

ASA FIXED CERAMIC-DIELECTRIC CAPACITOR

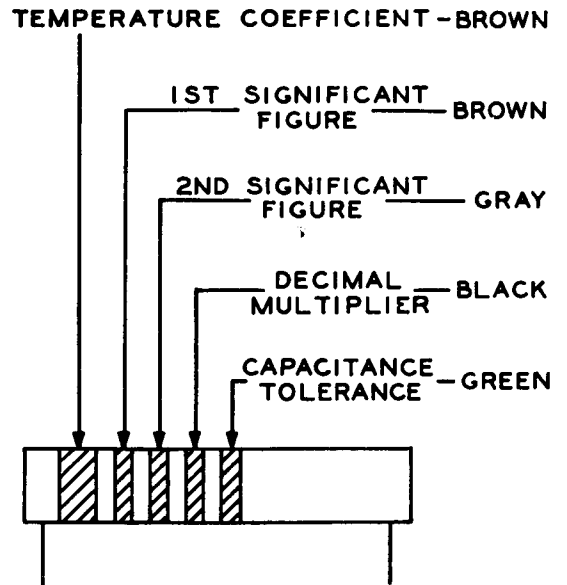

EXAMPLE: 18MMF ± 5% TEMPERATURE COEFFICIENT -30

Figure 6-13. ASA Fixed Ceramic-Dielectric Capacitor Color Code

(3) FIXED CERAMIC-DIELECTRIC CAPACITORS.

(a) TYPE DESIGNATION.

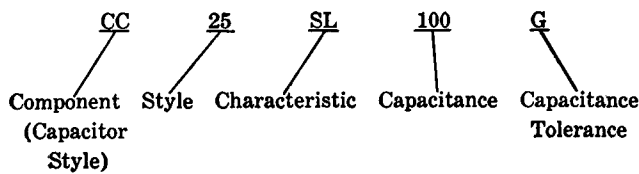



(b) COLOR CODE. (Refer to figure 6-13.)

Color	Significant Figure	Multiplier	± Tolerance of Capacitance*		
			Capacitors of Greater than 10 $\mu\mu\text{f}$ Tol. in Percent	Capacitors of 10 $\mu\mu\text{f}$ or Smaller Tol. in $\mu\mu\text{f}$	Temperature Coefficient of Capacitance Parts/Million/°C
Black	0	1	20 (M)	2.0 (G)	0
Brown	1	10	1 (F)	—	— 30
Red	2	100	2 (G)	—	— 80
Orange	3	1000	—	—	—150
Yellow	4	—	—	—	—220
Green	5	—	5 (J)	0.5 (D)	—330
Blue	6	—	—	—	—470
Violet	7	—	—	—	—750
Gray	8	0.01	—	0.25 (C)	+ 30
White	9	0.1	10 (K)	1.0 (F)	—330 ± 500

\* The letter symbol for each tolerance is given in parentheses after the tolerance value.

Capacitance Tolerance Designations		
Designation Letter	±Tolerance	
	Per cent	$\mu\mu\text{f}$
C	—	0.25
D	—	0.5
F	1	1.0
G	2	2.0
J	5	—
K	10	—
M	20	—

**Note**

All ASA ceramic-dielectric capacitors are rated at 500 WV.

(c) TEMPERATURE COEFFICIENT OF CAPACITANCE.

Letter Symbol	Temperature Coefficient of Capacitance Parts/Million/°C	Letter Symbol	Temperature Coefficient of Capacitance Parts/Million/°C
A	+100	K	— 68
B	+ 30	L	— 80
C	Zero	M	—100
D	— 5	N	—120
E	— 10	P	—150
F	— 15	R	—220
G	— 22	S	—330
H	— 30	T	—470
J	— 47	U	—750

AN 08-30ART13-5

(d) TOLERANCE ON TEMPERATURE COEFFICIENT OF CAPACITANCE.

Designation Letter	Tolerance on Temperature Coefficient in $\pm$ Parts per Million as given in preceding table.
F	15
G	30
H	60
J	120
K	250
L	500*

\* Available only in temperature coefficient S.

(4) FIXED MOLDED PAPER-DIELECTRIC CAPACITORS.

(a) TYPE DESIGNATION.

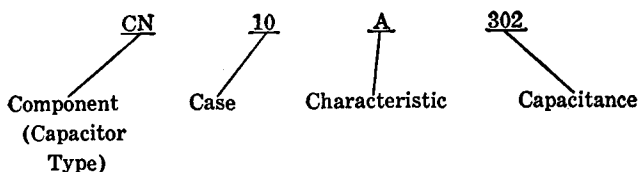

(b) COLOR CODE. (Refer to figure 6-14.)

Where marking of the type designation is not permitted by space or existing molds, the capacitance and characteristic may be indicated by color coding as given in the following table. A silver dot in the upper left-hand corner and in the lower center identifies a capacitor of this type.

ASA FIXED MOLDED PAPER-DIELECTRIC CAPACITOR

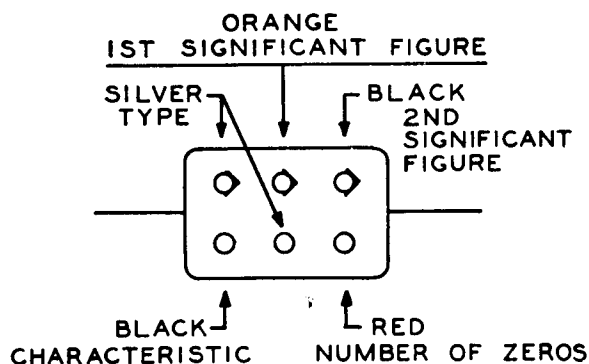

EXAMPLE: 3000 MMF "B" CHARACTERISTIC

Figure 6-14. ASA Fixed Molded Paper Dielectric Capacitor Color Code

Color No.	Color	Significant Figure	Decimal Multiplier	Characteristic or Grade
—	Black	0	1	A
70118	Brown	1	10	B
70179	Red	2	100	
70071	Orange	3	1000	
70067	Yellow	4		
70063	Green	5		
70209	Blue	6		
70058	Violet	7		
70170	Gray	8		
70001	White	9		
—	Gold			
—	Silver			

Note

The colors specified in the preceding table indicate the color shades as shown on

the Standard Color Card of America, 9th Edition.

(c) VOLTAGE RATING.

Type Designation	Dimensions in Inches			Capacitance in Micromicrofarads	WV
CN35A302	53/64	53/64	11/32	3000	800
CN35A602	53/64	53/64	11/32	6000	600
CN35A103	53/64	53/64	11/32	10000	400
CN36A302	53/64	53/64	9/32	3000	400
CN36A602	53/64	53/64	9/32	6000	400
CN36A103	53/64	53/64	9/32	10000	300
CN40B302	1-1/32	41/64	11/32	3000	400
CN40B602	1-1/32	41/64	11/32	6000	300
CN40B103	1-1/32	41/64	11/32	10000	300
CN41B302	1-5/32	5/8	1/4	3000	600
CN41B602	1-5/32	5/8	1/4	6000	600
CN41B103	1-5/32	5/8	1/4	10000	400

(d) CHARACTERISTICS OR GRADES.

	Characteristics or Grades	
	A	B
Operating Temperature Range		
Centigrade (degrees) . . . . .	-55 to + 85	-55 to + 75
Fahrenheit (degrees) . . . . .	-67 to +185	-67 to +167
Maximum Capacitance Reduction between +20°C and -40°C . . . . .	10 per cent	10 per cent
Capacitance Tolerance in per cent . . . . .	+60 -20	+60 -20

(5) FIXED COMPOSITION RESISTORS.

(a) TYPE DESIGNATION.

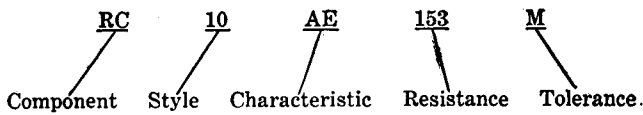

(b) COLOR CODE. (Refer to figure 6-15, and figure 6-16.)

Color	Numeral or Number of Zeros	Decimal Multiplier	Tolerance
Black	0		—
Brown	1		—
Red	2		—
Orange	3		—
Yellow	4		—
Green	5		—
Blue	6		—
Violet	7		—
Gray	8		—
White	9		—
Gold	—	0.1	± 5 per cent (J)
Silver	—	0.01	±10 per cent (K)
No Color	—	—	±20 per cent (M)

ASA FIXED COMPOSITION RESISTOR

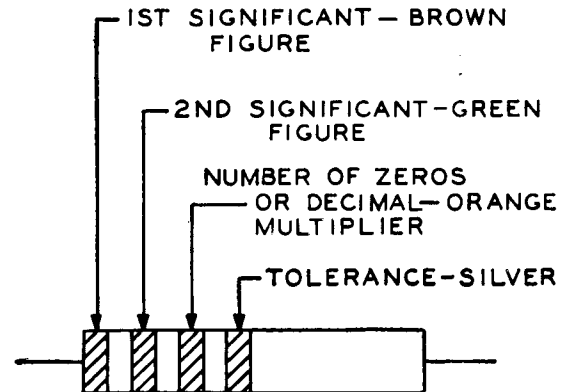

EXAMPLE: 15000Ω ± 10%

Figure 6-15. ASA Fixed Composition Resistor Color Code

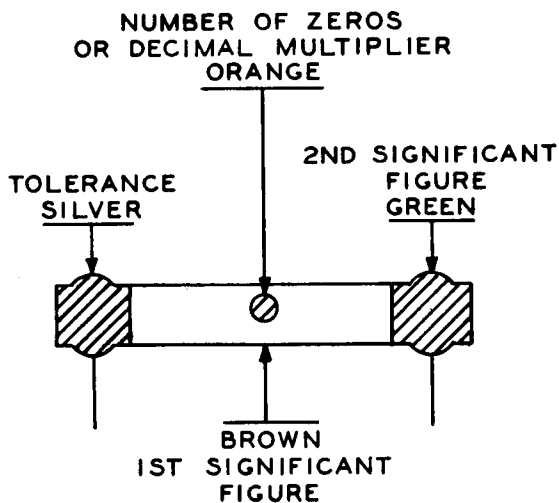
ASA ALTERNATE COLOR CODING  
FOR RADIAL-LEAD RESISTOR

EXAMPLE:  $15000\Omega \pm 10\%$

Figure 6-16. ASA Alternate Color Coding for Radial-Lead Resistor

c. HOOKUP WIRE CODE.—This wire code is the standard code for all unit wiring in connection with the Model AN/ART-13 Radio Transmitting Equipment.

(1) Two classes of wire are employed, consisting of flame resistant and bus-bar.

(2) Flame resistant wire is supplied in two degrees of insulation rated at 1000 volts and 3000 volts. The voltage rating of the wire is indicated by an identification thread in the strands of the conductor. A blue thread indicates 1000 volts insulation while a white thread indicates 3000 volts insulation. Two other threads of different colors serve to indicate the manufacturer of the wire and the year in which it was made.

(3) Standard RMA Color Code Numerals are used for designating the body color and the color of the tracers. This code is as follows:

0—Black	5—Green
1—Brown	6—Blue
2—Red	7—Violet
3—Orange	8—Gray
4—Yellow	9—White

(4) The wire color code is made up of a letter designating the wire size and voltage rating of insulation followed by numerals designating the body color and the colors of up to three tracers.

(5) A shielded flame resistant wire is indicated by inserting the letter S after the first letter of the code. Example: AS956 indicates a white wire with green and blue tracers in a tinned shielding braid.

(6) The wire code used in the AN/ART-13 Equipment is as follows:

**Note**

Wires employing code numbers 4, 7 and 8 are not used.

TABLE 6-2  
AN/ART-13 CABLE WIRE CODE

Color Code	Body Color	First Tracer Color	Second Tracer Color	Third Tracer Color	Wire Specifications
*A9	White				Number 22 AWG Stranded Tinned Copper Fire Resistant Insulation 1000 volt rating
*A90	White	Black			
*A92	White	Red			
*A93	White	Orange			
*A95	White	Green			
*A96	White	Blue			
A902	White	Black	Red		
A9020	White	Black	Red	Black	
A9023	White	Black	Red	Orange	
A9025	White	Black	Red	Green	
A9026	White	Black	Red	Blue	
A903	White	Black	Orange		
A9030	White	Black	Orange	Black	
A9035	White	Black	Orange	Green	
A9036	White	Black	Orange	Blue	
A905	White	Black	Green		
A9050	White	Black	Green	Black	
A906	White	Black	Blue		
A9060	White	Black	Blue	Black	
A9202	White	Red	Black	Red	
A923	White	Red	Orange		
A925	White	Red	Green		
A9252	White	Red	Green	Red	
A9256	White	Red	Green	Blue	
A926	White	Red	Blue		
A9262	White	Red	Blue	Red	
A9303	White	Orange	Black	Orange	
A935	White	Orange	Green		
A9353	White	Orange	Green	Orange	
A9356	White	Orange	Green	Blue	
A936	White	Orange	Blue		
A9363	White	Orange	Blue	Orange	
A9505	White	Green	Black	Green	
A9525	White	Green	Red	Green	
A9535	White	Green	Orange	Green	
A956	White	Green	Blue		
A9606	White	Blue	Black	Blue	
A9626	White	Blue	Red	Blue	
A9636	White	Blue	Orange	Blue	

\* Shielded wire using this code is also available. The letter "S" is added to the above code to indicate shielding. Example: AS93.

TABLE 6-2 (Continued)

Color Code	Body Color	First Tracer Color	Second Tracer Color	Third Tracer Color	Wire Specifications
B9 *B90 B91 B92 B93 B94 B95 B96 B902 B925	White White White White White White White White White	Black Brown Red Orange Yellow Green Blue Black Red		Red Green	Number 20 AWG Stranded Tinned Copper Fire Resistant Insulation 1000 volt rating
C9 C92 *C93 C902 C903 C925 C935	White White White White White White	Red Orange Black Black Red Orange		Red Orange Green Green	Number 18 AWG Stranded Tinned Copper Fire Resistant Insulation 1000 volt rating
D9 D90 D91 D92 D93 D95 D96 D902 D903 D925 D935 D936	White White White White White White White White White White White White	Black Brown Red Orange Green Blue Black Black Red Orange Orange		Red Orange Green Green Blue	Number 16 AWG Stranded Tinned Copper Fire Resistant Insulation 1000 volt rating
E9 E90 E92 E920 E925	White White White White White	Black Red Red Red		Black Green	Number 14 AWG Stranded Tinned Copper Fire Resistant Insulation 1000 volt rating
F9 F91	White White	Brown			Number 12 AWG Stranded Tinned Copper Fire Resistant Insulation 1000 volt rating
J9 J90	White White	Black			Number 6 AWG Stranded Tinned Copper Fire Resistant Insulation 1000 volt rating

\* Shielded wire using this code is also available. The letter "S" is added to the above code to indicate shielding. Example: AS93.

TABLE 6-2 (Continued)

Color Code	Body Color	First Tracer Color	Second Tracer Color	Third Tracer Color	Wire Specifications
L92	White	Red			Number 20 AWG Stranded Tinned Copper Fire Resistant Insulation 3000 volt rating
L96	White	Blue			
N90	White	Black			Number 16 AWG Stranded Tinned Copper Fire Resistant Insulation 3000 volt rating
N92	White	Red			
N95	White	Green			
N96	White	Blue			
N906	White	Black	Blue		

d. CODE FOR BUS-BAR.—The code for bus-bar is made up of the letter designation BB followed by the wire size as shown below:

Number 20—BB20      Number 14—BB14  
Number 18—BB18      Number 12—BB12  
Number 16—BB16

5. GENERAL SPECIFICATIONS OF EQUIPMENT.

a. FREQUENCY RANGE.—2000 kc to 18,100 kc

Note

The addition of the Type O-17/ART-13 Low Frequency Oscillator, the O-16/ART-13 Low Frequency Oscillator, the Type CU-25/ART-13, Type CU-26/ART-13 and the Type CU-32/ART-13A to the Type T-47/ART-13 Equipment extends the frequency range to include 200 kc to 600 kc with the O-17/ART-13 Oscillator or 200 kc to 1500 kc with the O-16/ART-13 Oscillator.

b. FREQUENCY BANDS.

(1) When the installation is equipped with the Type O-17/ART-13A LF oscillator, the range 200 kc to 600 kc is covered in three bands by Control "F".

Position of Control F	Frequency Range
1	200 kc to 285 kc
2	285 kc to 415 kc
3	415 kc to 600 kc

(2) When the installation is equipped with the Type O-16/ART-13 LF oscillator, the range 200 kc to 1500 kc is covered in six bands by Control "F".

Position of Control F	Frequency Range
1	200 kc to 262 kc
2	262 kc to 355 kc
3	355 kc to 475 kc
4	475 kc to 695 kc
5	695 kc to 1035 kc
6	1035 kc to 1500 kc

(3) The frequency range 2000 kc to 18,100 kc is covered by twelve bands. The twelve positions of Control A frequency range covered by each are listed below:

Position of Control A	Frequency Range
1	2.0 mc to 2.4 mc
2	2.4 mc to 3.0 mc
3	3.0 mc to 3.6 mc
4	3.6 mc to 4.0 mc
5	4.0 mc to 4.8 mc
6	4.8 mc to 6.0 mc
7	6.0 mc to 7.2 mc
8	7.2 mc to 9.0 mc
9	9.0 mc to 10.8 mc
10	10.8 mc to 12.0 mc
11	12.0 mc to 14.4 mc
12	14.4 mc to 18.1 mc

c. FREQUENCY STABILITY.

(1) FREQUENCY VARIATION WITH TEMPERATURE CHANGE.

Temp. Change	% Frequency Deviation			
	2.0 mc	2.4 mc	3.0 mc	6.0 mc
-10°C (14°F) to 0°C (32°F)	0.0006	0.0027	0.0011	0.0116
0°C (32°F) to 10°C (50°F)	0.0014	0.0027	0.0004	0.0147
10°C (50°F) to 20°C (68°F)	0.0009	0.0044	0.0008	0.0123
20°C (68°F) to 30°C (86°F)	0.0030	0.0018	0.0027	0.0124
30°C (86°F) to 40°C (104°F)	0.0000	0.0042	0.0015	0.0109
40°C (104°F) to 50°C (122°F)	0.0042	0.0040	0.0015	0.0126

(2) FREQUENCY VARIATION WITH CHANGE IN HUMIDITY.

Humidity Change	% Frequency Deviation			
	2.0 mc	2.4 mc	3.0 mc	6.0 mc
30% to 95%	0.0073	0.0058	0.0097	0.0153
95% to 30%	0.0046	0.0000	0.0050	0.0133

**d. ANTENNA REQUIREMENTS.**

Fre- quency	Antenna Reactance	Antenna Resistance	Fre- quency	Antenna Reactance	Antenna Resistance
200 kc	-2000 ohms	10 ohms	2.0 mc	-500 ohms	2.1 ohms
300	-1150	9.5	3.0	-200	3.1
400	- 750	7.0	4.0	0	6.1
500	- 580	7.0	5.5	+380	25.0
600	- 480	8.0	7.0	0	3500.0
700	- 380	8.0	9.0	-350	50.0
800	- 300	10.0	11.5	0	50.0
1.0 mc	- 210	18.0	13.5	+350	100.0
1.3	- 122	12.0	15.5	0	1500.0
1.5	- 106	12.0	18.1	-350	200.0

**e. POWER OUTPUT.**

Fre- quency	Power Output	Fre- quency	Power Output	Fre- quency	Power Output
0.2 mc	5.5 watts	1.0 mc	75.0 watts	7.0 mc	90.0 watts
0.3	14.0	1.3	80.0	9.0	90.0
0.4	18.0	1.5	65.0	11.5	90.0
0.5	24.0	2.0	31.0	13.5	90.0
0.6	24.0	3.0	60.0	15.5	75.0
0.7	27.0	4.0	80.0	18.1	65.0
0.8	45.0	5.5	90.0		

**Note**

All power output measurements were made with 28 volt dc input to the dynamotor.

**f. INPUT IMPEDANCE.**—The audio input circuit of the equipment is designed to match the output of either a carbon or dynamic microphone. A switch selects the proper input circuit to correspond to the type of microphone that is to be used. When the microphone circuit selector switch is in the CARBON position the input circuit will match a carbon microphone of approximately 40 ohms internal resistance. When the circuit selector switch is in the DYNAMIC position the input circuit will match a dynamic microphone of approximately 200 ohms internal resistance.

**g. POWER SOURCE.**

The equipment is designed to operate from any source of 28 volts direct current capable of supplying at least 36 amperes.

**h. POWER INPUT.**

Type of Emission	Full Power Operation	Reduced Power Operation
CW	770 watts	658 watts
CW (Stand-by)	505 watts	486 watts
MCW	855 watts	700 watts
MCW (Stand-by)	536 watts	510 watts
VOICE (No Modulation)	800 watts	672 watts
VOICE	800 watts	700 watts
VOICE (Stand-by)	235 watts	235 watts
(90% Modulation)		

**Note**

The above measurements show the total power drawn from the power source under the stated conditions with a normal supply voltage of 28 volts.

**i. DYNAMOTORS.****(1) TYPE DY-11/ART-13 DYNAMOTOR  
POWER UNIT DYNAMOTOR.**

Manufacturer:	Russell Electric Co. Chicago, Illinois
Russell Type:	502D3C04
Rated Input:	27 volts dc, 32 amps.
Rated Output:	400 v dc, 0.750 amp. 750 v dc, 0.350 amp.
Ambient Temperature:	-40° to +50°C
Humidity:	Up to 90%, moist sea atmosphere.
Altitude:	Up to 40,000 feet above sea level.
Vibration:	All frequencies between 10-57 cycles per second with an amplitude of .03 inch (.06 total excursion).
Position:	Any

**(2) TYPE DY-12/ART-13 DYNAMOTOR  
POWER UNIT DYNAMOTOR.**

Manufacturer:	Wincharger Corporation Sioux City, Iowa
Wincharger Type:	51S1
Rated Input:	27 volts dc, 32 amps.
Rated Output:	400 v dc., 0.750 amp. 750 v dc, 0.350 amp.
Ambient Temperature:	-40° to +50°C
Humidity:	Up to 90%, moist sea atmosphere.
Altitude:	Up to 40,000 feet above sea level.
Vibration:	All frequencies between 10-57 cycles per second with an amplitude of .03 inch (.06 total excursion).
Position:	Any

**(3) TYPE DY- /ART-13 DYNAMOTOR  
POWER UNIT DYNAMOTOR.**

Manufacturer:	Fractional Motors Co. Chicago, Illinois
Fractional Type:	D-100
Rated Input:	27 volts dc, 32 amps.
Rated Output:	400 v dc, 0.750 amp. 750 v dc, 0.350 amp.



**Section VI**  
**Paragraphs 5-7**

**AN 08-30ART13-5**

Ambient Temperature —40° to +50°C

Humidity: Up to 90%, moist sea atmosphere.

Altitude: Up to 40,000 feet above sea level.

Vibration: All frequencies between 10-57 cycles per second with an amplitude of .03 inch (.06 total excursion).

Position: Any

*j.* MODULATION.—Class B modulation is employed in the equipment. The push-pull modulators are capable of modulating the full-power rf carrier at least 90% with VOICE emission.

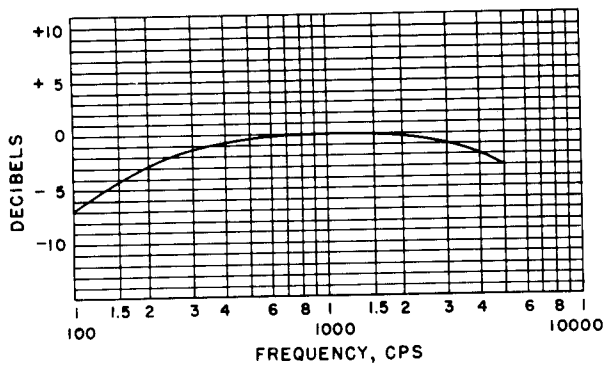

**Figure 6-17. Overall Frequency Response Curve at 90% Modulation**

**6. TUBE COMPLEMENT.**

<u>Tube Type</u>	<u>Quantity</u>	<u>Function</u>
837	1	HF Oscillator
1625	1	1st Frequency Multiplier
1625	1	2nd Frequency Multiplier
813	1	Power Amplifier
811	2	Modulators

<u>Tube Type</u>	<u>Quantity</u>	<u>Function</u>
12SJ7	1	Audio Amplifier
6V6GT	1	Audio Driver
6V6GT	1	Sidetone Amplifier
12SL7GT	1	Crystal Oscillator-Tripler
12SA7	1	Mixer
12SL7GT	1	Detector-Audio Oscillator

**Note**

All tubes are located in the Type AN/ART-13 Transmitter Unit. When a LF oscillator is included with the transmitter, an additional Type 1625 tube will be added to the Tube Complement.

**WARNING**

In order to obtain satisfactory tube life the following precautions must be taken: Operate all tube filaments within  $\pm 5\%$  of rated voltage.

Do not exceed rated plate current in any of the tubes during normal operation of the equipment.

When tuning, do not exceed rated plate current except for periods of short duration.

Failure to observe the above precautions may result in the destruction of the tubes.

All tubes supplied with the equipment or as spares on the equipment contract shall be used in the equipment prior to employment of tubes from general stock.

**7. CHARACTERISTICS OF VACUUM TUBES USED IN THE AN/ART-13 EQUIPMENT**

**Note**

The following tube data is reproduced by permission of the Radio Corporation of America.

12SJ7 - 12SJ7-GT

The 12SJ7 and 12SJ7-GT are same as the 6SJ7 and 6SJ7-GT respectively except for heater rating. The 12SJ7-12SJ7-GT heater rating is 12.6 volts, 0.15 amp.

6V6, 6V6-GT/G

BEAM POWER AMPLIFIER

Heater Voltage	6.3	a-c or d-c volts
Current	0.45	amp.
Direct Inter-electrode Capacities (Approx.):	0.3	0.7
Grid to Plate	10	0.7
Input	11	9.5
Output	11	9.5
Maximum Overall Length	2-1/4"	3-5/16"
Maximum Seated Height	1-5/16"	2-3/4"
Maximum Diameter	1-5/16"	1-5/16"
Bulb	Small Shell, MT-8	Intermed. Sh.
Base	{ Octal 7-Pin	{ Octal 7-Pin
Basing Designation	7AC	G-7AC
Pin 1	{ 6V6-GT/G, No Con.	Pin 4 - Screen
Pin 2	Heater	Pin 5 - Grid
Pin 3	Plate	Pin 7 - Heater
Mounting Position	Any	Pin 8 - Cathode

Maximum Ratings Are Design-Center Values

SINGLE-TUBE AMPLIFIER

Plate Voltage	315 max.	volts
Screen Voltage	285 max.	volts
Plate Dissipation	12 max.	watts
Screen Dissipation	2 max.	watts
Typical Operation and Characteristics - Class A <sub>1</sub> Amplifier:		
Plate Voltage	180	250
Screen Voltage	180	225
Grid Voltage	-8.5	-12.5
Peak A-F Grid Volt.	8.5	12.5
Zero-Sig. Plate Cur.	28	45
Max.-Sig. Plate Cur.	30	47
Zero-Sig. Screen Cur.	3	4.5
Max.-Sig. Screen Cur.	4	5.5
Plate Resistance	58000	52000
Transconductance	3700	4100
Load Resistance	5500	5000
Tot. Harmonic Dist.	8	8
Max.-Sig. Power Output	2	4.5

PUSH-PULL AMPLIFIER

Plate Voltage	315 max.	volts
Screen Voltage	285 max.	volts
Plate Dissipation	12 max.	watts
Screen Dissipation	2 max.	watts

In circuits where the cathode is not directly connected to the heater, the potential difference between heater and cathode should be kept as low as possible, with shell or external shield connected to cathode. With screen and suppressor connected to cathode. With screen and suppressor connected to plate. † Indicates a change. ‡ See next page.

6V6, 6V6-GT/G

BEAM POWER AMPLIFIER

(continued from preceding page)

Typical Operation and Characteristics - Class A<sub>1</sub> Amplifier: Unless otherwise specified, values are for 2 tubes

Plate Voltage	250	285	volts
Screen Voltage	250	285	volts
Grid Voltage	-15	-19	volts
Peak A-F Grid-to-Grid Volt.	30	38	volts
Zero-Sig. Plate Cur.	79	70	ma.
Max.-Sig. Plate Cur.	79	92	ma.
Zero-Sig. Screen Cur.	5	4 approx. ma.	
Max.-Sig. Screen Cur.	13	13.5 approx. ma.	
Plate Resistance	60000	65000 approx. ohms	
Transconductance	3750	3600	ohms
Effec. Load Res.	10000	8000	ohms
Total Harmonic Dist.	5	3.5	%
Max.-Sig. Power Output	10	14	watts

The type of input coupling used should not introduce too much resistance in the grid circuit. Transformer or impedance-coupling devices should be used where the grid-cathode bias is less than 0.1 megohm. For higher values, cathode bias is required. With cathode bias, the grid circuit may have a resistance not to exceed 0.5 megohm.

6SJ7, 6SJ7-GT

TRIPLE-GRID DETECTOR AMPLIFIER

Heater Voltage	6.3	a-c or d-c volts
Current	0.3	amp.
Direct Inter-electrode Capacities (Approx.):	0.005	0.005
Grid to Plate	6.0	6.3
Input	2.8	3.0
Output	3.8	3.8
Maximum Overall Length	2-5/16"	2-5/16"
Maximum Seated Height	1-5/16"	1-5/16"
Maximum Diameter	1-5/16"	1-5/16"
Bulb	Small Water Octal 8-Pin	Small Water Octal 8-Pin
Base	Small Water Octal 8-Pin	Small Water Octal 8-Pin
Basing Designation	8H	8H
Pin 1	{ 6SJ7-GT, No Con.	Pin 4 - Grid
Pin 2	Heater	Pin 5 - Grid
Pin 3	Plate	Pin 6 - Screen
Mounting Position	Any	Pin 8 - Plate

Maximum Ratings Are Design-Center Values

AMPLIFIER (Triode Connection)†

Plate Voltage	300 max.	volts
Screen Voltage	125 max.	volts
Screen Supply Voltage	300 max.	volts
Grid Voltage	0 min.	volts
Plate Dissipation	2.5 max.	watts
Screen Dissipation	0.5 max.	watt
Typical Operation and Characteristics - Class A <sub>1</sub> Amplifier:		
Plate Voltage	100	250
Screen Voltage	100	100
Grid Voltage	-3	-3
Peak A-F Grid Volt.	0.7	0.7
Zero-Sig. Plate Cur.	1575	1650
Max.-Sig. Plate Cur.	2.9	3
Zero-Sig. Screen Cur.	0.9	0.8
Max.-Sig. Screen Cur.	0.9	0.8

AMPLIFIER (Triode Connection)‡

Plate Voltage	250 max.	volts
Screen Voltage	0 min.	volts
Plate Dissipation	2.5 max.	watts
Screen Dissipation	0.5 max.	watt
Typical Operation and Characteristics - Class A <sub>1</sub> Amplifier:		
Plate Voltage	180	250
Screen Voltage	180	250
Grid Voltage	-6	-8.5
Peak A-F Grid Volt.	19	19
Zero-Sig. Plate Cur.	8250	7600
Max.-Sig. Plate Cur.	2300	2500
Zero-Sig. Screen Cur.	6	9.2
Max.-Sig. Screen Cur.	6	9.2

In circuits where the cathode is not directly connected to the heater, the potential difference between heater and cathode should be kept as low as possible, with shell or external shield connected to cathode. With screen and suppressor connected to cathode. With screen and suppressor connected to plate. † Indicates a change. ‡ See next page.

811

**TRANSMITTING TRIODE**

(Continued from preceding page)

	CCS	ICZS
Peak R-F Grid Voltage	180	225
D-C Plate Current	125	150
D-C Grid Current	35 approx.	35 approx. ma.
Driving Power**	7 approx.	8 approx. watts
Power Output	115 approx.	170 approx. watts

\*\* Subject to wide variations as explained on sheet TRANS. TUBE RATINGS.

† HIGH-FREQUENCY OPERATION

‡ Maximum Permissible Percentage of maximum rated plate voltage and plate input.

FREQUENCY (MC)	60	80	100
TELEPHONY (Class B, Plate Mod.)	100	90	83
TELEGRAPHY (Class C)	100	75	60

OUTLINE DIMENSIONS for the 811 are the same as those for the 809.

811

**TRANSMITTING TRIODE**

(Continued from preceding page)

	CCS	ICZS
D-C Grid Voltage	0	-5
Peak R-F Grid Voltage	26	35
D-C Plate Current	48	50
D-C Grid Current	6 approx.	6 approx. ma.
Driving Power**	1 approx.	1.5 approx. watts
Power Output	20 approx.	25 approx. watts

† At least of coils with modulation factor of 1.0.

‡ Grid voltages are given for either a-c or d-c filament operation. When a-c is used, the circuit returns are made to the midpoint of the filament circuit. When d-c is used, the returns are made to the negative filament terminal.

§ PLATE-MODULATED R-F POWER AMPLIFIER - Class C Telephony

Carrier conditions per tube for use with a max. modulation fact. of 1.0

	CCS	ICZS
D-C Plate Voltage	1000 max.	1250 max.
D-C Grid Voltage	-200 max.	-200 max.
D-C Plate Current	105 max.	125 max.
D-C Grid Current	50 max.	50 max.
Plate Input	105 max.	155 max.
Plate Dissipation	27 max.	40 max.

Typical Operation:

	CCS	ICZS
D-C Plate Voltage	1000	1250
D-C Grid Voltage	-100	-125
D-C Plate Current	2000	2500
D-C Grid Current	195	230
Peak R-F Grid Voltage	105	125
D-C Plate Current	50 approx.	50 approx. ma.
D-C Grid Current	9 approx.	11 approx. watts
Driving Power**	82 approx.	120 approx. watts
Power Output		

† Obtained preferably from grid leak of value shown, or combination of grid leak with either fixed supply or suitably bypassed cathode resistor.

‡ R-F POWER AMPLIFIER & OSCILLATOR - Class C Telephony

Key-down conditions per tube without modulation

	CCS	ICZS
D-C Plate Voltage	1250 max.	1500 max.
D-C Grid Voltage	-200 max.	-200 max.
D-C Plate Current	125 max.	150 max.
D-C Grid Current	50 max.	50 max.
Plate Input	155 max.	225 max.
Plate Dissipation	40 max.	55 max.

Typical Operation:

	CCS	ICZS
D-C Plate Voltage	1250	1250
D-C Grid Voltage	-87.5	-113
D-C Plate Current	2500	3200
D-C Grid Current	550	610

† Modulation essentially negative. ‡ Obtained from fixed supply. § Cathode resistor (550, 610). ¶ See next page.

811

**TRANSMITTING TRIODE**

Thoriated Tungsten

a-c or d-c volts amp.

6.2 4

Amplification Factor 160

Direct Inter-electrode Capacitances:

Grid to Plate puf

Grid to Filament puf

Plate to Filament puf

Maximum Overall Length 6-9/16"

Maximum Diameter 2-7/16"

Bulb ST-19

Cap Medium Metal

Base Medium 4-Pin, "Micanol"

RCA Socket UR-542-A

**MAXIMUM CCS and ICAS RATINGS**

with TYPICAL OPERATING CONDITIONS

CCS = Continuous Commercial Service

ICZS = Intermittent Commercial and Amateur Service

A-F POWER AMPLIFIER & MODULATOR - Class B

	CCS	ICZS
D-C Plate Voltage	1250 max.	1500 max.
Max.-Sig. D-C Plate Current*	125 max.	125 max.
Max.-Sig. Plate Input*	125 max.	150 max.
Plate Dissipation*	40 max.	50 max.

Typical Operation:

\* Unless otherwise specified, values are for 2 tubes

	CCS	ICZS
D-C Plate Voltage	1250	1500
D-C Grid Voltage	0	-9
Peak A-F Grid-to-Grid Volt.	140	160
Zero-Sig. D-C Plate Current	20	20
Max.-Sig. D-C Plate Current	200	238
Max.-Sig. D-C Grid Current	38	4500
Load Resistance (per tube)	3750	
Effective Load Resistance (plate to plate)	18000	
Max.-Sig. Driving Power	3.8 approx.	4.2 approx. watts
Max.-Sig. Power Output	175 approx.	225 approx. watts

\* Averaged over any audio-frequency cycle of sine-wave form.

† R-F POWER AMPLIFIER - Class B Telephony

Carrier conditions per tube for use with a max. modulation fact. of 1.0

	CCS	ICZS
D-C Plate Voltage	1250 max.	1500 max.
D-C Plate Current	60 max.	60 max.
Plate Input	60 max.	75 max.
Plate Dissipation	40 max.	50 max.

Typical Operation:

	CCS	ICZS
D-C Plate Voltage	1250	1500

† See next page.

1625

**TRANSMITTING BEAM POWER AMPLIFIER**

Heater<sup>0</sup> Coated Unipotential Cathode a-c or d-c volts  
 Voltage 12.6  
 Current 0.45 amp.  
 Maximum Overall Length 5-3/4"  
 Maximum Diameter 2-1/16"  
 Bulb ST-16  
 Base Small Metal  
 Cap Medium 7-Pin, MICANOL<sup>®</sup> Bayonet

<sup>0</sup> In circuits where the cathode is not directly connected to the heater, the potential difference between them should not exceed 100 volts. Use a resistor in series with the heater connections, the heater voltage should not fluctuate so that it exceeds 14 volts.  
 \* Registered trademark.

Except for the heater rating, the electrical characteristics of the 1625 are the same as those of the 807.

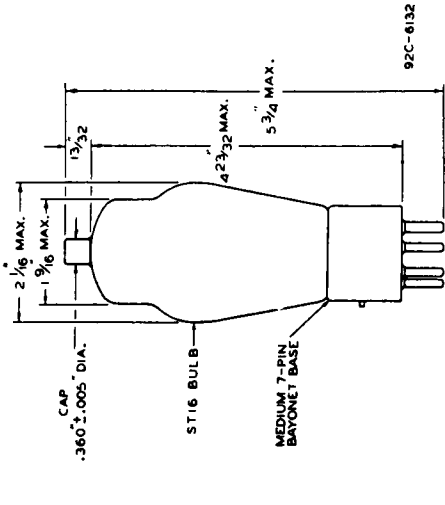

BOTTOM VIEW OF SOCKET CONNECTIONS.

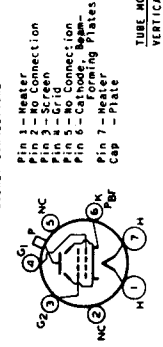

TUBE MOUNTING POSITION  
 VERTICAL or HORIZONTAL

Except for the heater rating, the electrical characteristics of the 1625 are the same as those of the 807 shown below. The heater rating of the 1625 is 12.6 volts, 0.45 amps.

807

TRANSMITTING BEAM POWER AMPLIFIER

Heater Voltage	Coated Unipotential Cathode	a-c or d-c volts
Current	6.3	amp.
Transconductance for plate cur. of 72 ma.	6000 approx.	μmhos
Grid-Screen Mu-Factor	8	
Direct Inter-electrode Capacitances:		
Grid to Plate (with external shielding)	0.2 max.	μpf
Input	11	μpf
Output	7	μpf
Maximum Overall Length	5-3/4"	
Maximum Diameter	2-1/16"	
Bulb	Small Metal	
Cap	Medium 5-Pin, MICANOL	
Base		

**MAXIMUM CCS and ICAS RATINGS**  
with TYPICAL OPERATING CONDITIONS  
CCS = Continuous Commercial Service  
ICAS = Intermittent Commercial and Instaur Service

A-F POWER AMPLIFIER & MODULATOR - Class AB <sub>2</sub>		
D-C Plate Voltage	750 max.	volts
D-C Screen Voltage (Grid #2)	300 max.	volts
Max.-Signal D-C Plate Cur.*	120 max.	ma.
Max.-Signal Plate Input*	90 max.	watts
Screen Input*	3.5 max.	watts
Plate Dissipation†	25 max.	watts
* Unless otherwise specified, values are for 2 tubes		
D-C Plate Voltage	400	volts
D-C Screen Voltage	300	volts
D-C Grid Voltage	-25	-30
Peak A-F Grid-to-Grid Voltage	78	volts
Zero-Sig. D-C Plate Cur.	100	ma.
Max.-Sig. D-C Plate Cur.	240	ma.
Zero-Sig. D-C Screen Cur.	5	ma.
Max.-Sig. D-C Screen Cur.	10	ma.
Load Resistance (Per tube)	800	ohms
Effective Load Resistance (Plate to plate)	3200	ohms
Peak Grid Input Power †	0.2	0.1
Max.-Sig. Power Output**	55	75
Max.-Sig. Power Output***	55	80

\* In circuits where the cathode is not directly connected to the heater, the maximum plate and screen dissipation conditions, the heater voltage should not fluctuate so that it exceeds 7.0 volts.  
\*\* Subscript 2 indicates that grid current flows during some part of input cycle.  
\*\*\* Subscript 1 indicates that grid current flows during some part of input cycle.  
† Registered trademark.  
‡ See next page.

807

TRANSMITTING BEAM POWER AMPLIFIER

R-F POWER AMPLIFIER - Class B Telephony		
Carrier conditions per tube for use with a max. modulation factor of 1.0		
D-C Plate Voltage	600 max.	volts
D-C Screen Voltage (Grid #2)	300 max.	volts
Plate Input	80 max.	ma.
Screen Input	37.5 max.	45 max.
Plate Dissipation	25 max.	30 max.
D-C Plate Voltage	400	500
D-C Screen Voltage	250	250
D-C Grid Voltage (Grid #1)†	-25	-25
Peak R-F Grid Voltage	50	50
D-C Plate Current	75	75
D-C Screen Current	4	4
D-C Grid Cur. (Approx.)	0	0
Driving Power (Approx.)	0.25	0.2
Power Output (Approx.)	9	12.5
† At crest of a-c cycle with modulation factor of 1.0.		
PLATE-MODULATED R-F POWER AMPLIFIER - Class C Telephony		
Carrier conditions per tube for use with a max. modulation factor of 1.0		
D-C Plate Voltage	475 max.	600 max.
D-C Screen Voltage (Grid #2)	300 max.	300 max.
D-C Grid Voltage (Grid #1)	-200 max.	-200 max.
D-C Plate Current	83 max.	100 max.
D-C Grid Current	5 max.	5 max.
Plate Input	40 max.	60 max.
Screen Input	2.5 max.	2.5 max.
Plate Dissipation	16.5 max.	25 max.
D-C Plate Voltage	325	400
D-C Screen Voltage †	225	225
D-C Grid Voltage †	-75	-80
Peak R-F Grid Voltage	90	95
D-C Plate Current	80	83
D-C Screen Current	5	5.75

† Driver stage should be capable of supplying the grids of the class A<sub>2</sub> stage with the specified peak values at low distortion. The effective resistance per grid to correct the class A<sub>2</sub> stage should be kept below 700 ohms per grid to correct the class A<sub>2</sub> stage should be kept below 700 ohms. The highest desired resonance frequency should not exceed 700 ohms.  
‡ Obtained preferably from modulated fixed supply, or from modulated supply.  
§ Max. obtained from grid resistor (25000, 22800, 21300, 22500) although combination of either grid resistor and cathode resistor or grid resistor and fixed supply is recommended.  
¶ Grid resistor and fixed supply is recommended.  
\*\* In circuits where the cathode is not directly connected to the heater, the maximum plate and screen dissipation conditions, the heater voltage should not fluctuate so that it exceeds 7.0 volts.  
\*\*\* Subscript 2 indicates that grid current flows during some part of input cycle.  
† Registered trademark.  
‡ See next page.

1625

TRANSMITTING BEAM POWER AMPLIFIER

R-F POWER AMPLIFIER & OSCILLATOR - Class C Telephony		
Key-down conditions per tube without modulation		
D-C Plate Voltage	750 max.	volts
D-C Screen Voltage (Grid #2)	300 max.	volts
D-C Grid Voltage (Grid #1)	-200 max.	volts
D-C Plate Current	100 max.	ma.
D-C Grid Current	5 max.	ma.
Plate Input	3.5 max.	watts
Screen Input	25 max.	watts
Plate Dissipation	60 max.	watts
D-C Plate Voltage	400	500
D-C Screen Voltage †	250	250
D-C Grid Voltage	-45	-45
D-C Grid Voltage †	12800	12800
Peak R-F Grid Voltage	65	65
D-C Plate Current	100	100
D-C Screen Current	7.5	6
D-C Grid Cur. (Approx.)	3.5	3.5
Driving Power (Approx.)	0.2	0.2
Power Output (Approx.)	25	30

† The total effective grid-circuit resistance should not exceed 25000 ohms.  
‡ Modulation essentially negative may be used if the positive peak of the audio-frequency envelope does not exceed 11% of the carrier component.  
§ Obtained from separate source, from a potentiometer, or from plate supply through a series resistor of value shown.  
¶ Obtained from fixed supply, by grid resistor (12800), by cathode resistor (410), or by combination methods.

Data on operating frequencies for the 807 are given on the sheet TRANS. TUBE RATINGS vs FREQUENCY.

807



837

R-F POWER AMPLIFIER PENTODE

Heater <sup>o</sup> Voltage	Coated Unipotential Cathode	a-c or d-c volts
Current		amp.
Transconductance for plate current of 24 ma.	3400	μhos
Direct Inter-electrode Capacitances:		pf
Grid to Plate (with external shielding)	0.20 max.	
Input	16	
Output	10	
Maximum Overall Length	2-1/16"	
Maximum Diameter	5-7/8"	
Bulb	Small Metal	
Cap	Medium 7-Pin Ceramic, Bayonet	
Base	Small Metal	
<b>MAXIMUM RATINGS and TYPICAL OPERATING CONDITIONS</b>		
R-F POWER AMPLIFIER - Class B Telephony		
Carrier conditions per tube for use with a max. modulation factor of 1.0		
D-C Plate Voltage	500 max.	volts
D-C Suppressor Voltage (Grid #3)	200 max.	volts
D-C Screen Voltage (Grid #2)	200 max.	volts
D-C Plate Current	40 max.	ma.
Plate Input	16 max.	watts
Suppressor Input	5 max.	watts
Screen Input	5 max.	watts
Plate Dissipation	12 max.	watts
Typical Operation:		
D-C Plate Voltage	400	volts
D-C Suppressor Voltage	0	volts
D-C Screen Voltage	200	volts
D-C Grid Voltage (Grid #1)	-25	volts
D-C Grid Voltage (Grid #2)	-25	volts
D-C Grid Voltage (Grid #3)	-25	volts
Peak R-F Grid Voltage	28	volts
Internal Shield	25	volts
D-C Plate Current	35	ma.
D-C Screen Current	30	ma.
D-C Grid Current	10	ma.
Driving Power	1	0 approx. ma.
Power Output	4	5 approx. watts
* At crest of a-f cycle with modulation factor of 1.0.		
SUPPRESSOR-MODULATED R-F POWER AMPLIFIER - Class C Telephony		
Carrier conditions per tube for use with a max. modulation factor of 1.0		
D-C Plate Voltage	500 max.	volts
D-C Screen Voltage (Grid #2)	200 max.	volts
D-C Grid Voltage (Grid #1)	-200 max.	volts
D-C Grid Current	40 max.	ma.
D-C Plate Current	8 max.	ma.
Plate Input	16 max.	watts
Screen Input	8 max.	watts
Plate Dissipation	12 max.	watts
* Should not deviate more than ±10% from rated value.		
o See NOTE on DATA 3 page.		
← indicates a change.		

837

R-F POWER AMPLIFIER PENTODE

(continued from preceding page)		
Typical Operation:		
D-C Plate Voltage	400	500 volts
D-C Suppressor Voltage (Grid #3)	-55	-85 volts
D-C Screen Voltage	6500	14000 ohms
D-C Grid Voltage of	-20	-20 volts
Peak A-F Suppressor Voltage	2500	5700 ohms
Peak R-F Grid Voltage	55	65 volts
Internal Shield	45	32 volts
D-C Plate Current	35	30 ma.
D-C Screen Current	37	23 ma.
D-C Grid Current	8	3.5 approx. ma.
Driving Power	0.4	0.1 approx. watt
Power Output	4	5 approx. watts
Δ voltage taken from unmodulated plate-voltage supply through resistor.		
□ from fixed supply or grid-leak resistor.		
GRID-MODULATED R-F POWER AMPLIFIER - Class C Telephony		
Carrier conditions per tube for use with a max. modulation factor of 1.0		
D-C Plate Voltage	500 max.	volts
D-C Suppressor Voltage (Grid #3)	200 max.	volts
D-C Screen Voltage (Grid #2)	200 max.	volts
D-C Plate Current	40 max.	ma.
Plate Input	16 max.	watts
Suppressor Input	5 max.	watts
Screen Input	5 max.	watts
Plate Dissipation	12 max.	watts
Typical Operation:		
D-C Plate Voltage	400	500 volts
D-C Suppressor Voltage	0	volts
D-C Screen Voltage	200	200 volts
D-C Grid Voltage	-50	-45 volts
Peak R-F Grid Voltage	58	48 volts
Internal Shield	25	20 volts
D-C Plate Current	35	30 ma.
D-C Screen Current	9	7 ma.
D-C Grid Current	1	0 approx. ma.
Driving Power	0.5	0.2 approx. watt
Power Output	4	5 approx. watts
* At crest of a-f cycle with modulation factor of 1.0		
Pentode Connection		
PLATE-MODULATED R-F POWER AMPLIFIER - Class C Telephony		
Carrier conditions per tube for use with a max. modulation factor of 1.0		
D-C Plate Voltage	400 max.	volts
D-C Suppressor Voltage (Grid #3)	200 max.	volts
D-C Screen Voltage (Grid #2)	200 max.	volts
D-C Grid Voltage (Grid #1)	-200 max.	volts
D-C Plate Current	50 max.	ma.
← indicates a change.		

837

R-F POWER AMPLIFIER PENTODE

(continued from preceding page)		
Typical Operation:		
D-C Grid Current	8 max.	ma.
Plate Input	20 max.	watts
Suppressor Input	5 max.	watts
Plate Dissipation	8 max.	watts
D-C Plate Voltage	400	volts
D-C Suppressor Voltage	13000	ohms
D-C Screen Voltage	40	volts
D-C Grid Voltage	140	volts
D-C Grid Voltage	-40	volts
D-C Screen Voltage	800	ohms
D-C Grid Voltage	60	volts
Peak R-F Grid Voltage	45	volts
Internal Shield	20	volts
D-C Plate Current	5 approx. ma.	ma.
D-C Screen Current	0.3 approx. ma.	ma.
D-C Grid Current	11 approx. ma.	ma.
Driving Power	0.7 approx. watt	watt
Power Output	11 approx. watts	watts
* From modulated fixed supply or modulated plate-voltage supply through resistor.		
PLATE-MODULATED R-F POWER AMPLIFIER - Class C Telephony		
Pentode Connection - Grids #2 & #3 tied together		
Carrier conditions per tube for use with a max. modulation factor of 1.0		
D-C Plate Voltage	400 max.	volts
D-C Screen Voltage (Grids #2 & #3)	200 max.	volts
D-C Grid Voltage (Grid #1)	-200 max.	volts
D-C Plate Current	50 max.	ma.
Plate Input	8 max.	watts
Screen Input	20 max.	watts
Plate Dissipation	7.5 max.	watts
Typical Operation:		
D-C Plate Voltage	400	volts
D-C Screen Voltage	10000	ohms
D-C Grid Voltage	100	volts
D-C Grid Voltage	-70	volts
D-C Screen Voltage	1000	ohms
D-C Grid Current	100	ma.
D-C Plate Current	30	ma.
Driving Power	0.7 approx. watt	watt
Power Output	11 approx. watts	watts
** Preferably from unmodulated plate-voltage supply through resistor.		
Δ obtained by grid-leak resistor or by partial self-bias methods.		
§ See end of tabulation.		
← indicates a change.		

813

TRANSMITTING BEAM POWER AMPLIFIER

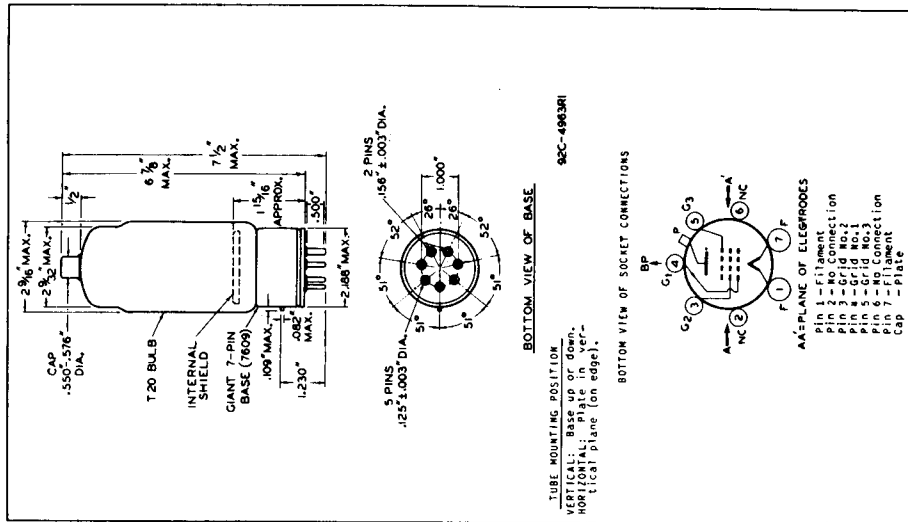



813 TRANSMITTING BEAM POWER AMPLIFIER

Filament Voltage	Thoriated Tungsten	a-c or d-c volts
Current	10, 0	amp.
Transconductance for plate current of 50 ma.	3750 approx.	μmhos
Direct Inter-electrode Capacitances:		
Grid to Plate (with external shielding)	0.2 max.	μf
Input	16, 3	μf
Output	14	μf
Maximum Overall Length	7-1/2"	
Maximum Diameter	2-9/16"	
Bulb	T-20	
Cap	Medium Metal	
Base	Giant 7-Pin, Bayonet	
RCA Socket	Type UT-104	
<b>MAXIMUM RATINGS and TYPICAL OPERATING CONDITIONS</b>		
R-F POWER AMPLIFIER - Class B Telephony		
Carrier conditions per tube for use with a max. modulation fact. of 1.0		
D-C Plate Voltage	2000 max.	volts
D-C Screen Voltage (Grid #2)	400 max.	volts
D-C Grid Voltage (Grid #1)	100 max.	volts
D-C Plate Current	150 max.	ma.
Plate Input	15 max.	watts
Screen Input	100 max.	watts
Plate Dissipation		
D-C Plate Voltage	1500	volts
D-C Screen Voltage (Grid #2)	400	volts
D-C Grid Voltage (Grid #1)	-60	volts
Peak R-F Grid Voltage	70	volts
Beam-Forming Plate Voltage	0	volts
D-C Plate Current	100	ma.
D-C Screen Current	4	ma.
D-C Grid Current	3	ma.
Driving Power	-	approx. watt
Power Output	50	approx. watts
* usually negligible. Fixed supply or by-passed cathode-resistor bias recommended.		
† usually negligible. Never more than 2 watts.		
GRID-MODULATED R-F POWER AMPLIFIER - Class C Telephony		
Carrier conditions per tube for use with a max. modulation fact. of 1.0		
D-C Plate Voltage	2060 max.	volts
D-C Screen Voltage (Grid #2)	400 max.	volts
D-C Grid Voltage (Grid #1)	-200 max.	volts
D-C Plate Current	150 max.	ma.
Plate Input	150 max.	watts
Screen Input	100 max.	watts
Plate Dissipation		
D-C Plate Voltage	1500	volts
D-C Screen Voltage (Grid #2)	400	volts
D-C Grid Voltage (Grid #1)	-200	volts
D-C Plate Current	150	ma.
Plate Input	150	watts
Screen Input	100	watts
Plate Dissipation		
D-C Plate Voltage	1500	volts
D-C Screen Voltage	400	volts
* , †, ‡: see end of tabulation.		

813 TRANSMITTING BEAM POWER AMPLIFIER

(continued from preceding page)		
D-C Grid Voltage	-140	volts
Peak R-F Grid Voltage	145	volts
Peak A-F Grid Voltage	60	volts
Beam-Forming Plate Voltage	0	volts
D-C Plate Current	70	ma.
D-C Screen Current	3	ma.
D-C Grid Current	-	approx. ma.
Driving Power	40	approx. watt
Power Output	50	approx. watts
* usually negligible. Fixed supply or unby-passed cathode-resistor bias recommended.		
† usually negligible. Never more than 2 watts.		
‡ usually negligible.		
PLATE-MODULATED R-F POWER AMPLIFIER - Class C Telephony		
Carrier conditions per tube for use with a max. modulation fact. of 1.0		
D-C Plate Voltage	1600 max.	volts
D-C Screen Voltage (Grid #2)	400 max.	volts
D-C Grid Voltage (Grid #1)	-300 max.	volts
D-C Plate Current	150 max.	ma.
D-C Screen Current	25 max.	ma.
D-C Grid Current	240 max.	ma.
Plate Input	15 max.	watts
Screen Input	67 max.	watts
Plate Dissipation		
D-C Plate Voltage	1250	volts
D-C Screen Voltage	400	volts
D-C Grid Voltage	-120	volts
Peak R-F Grid Voltage	30000	ohms
Beam-Forming Plate Voltage	195	volts
D-C Plate Current	0	volts
D-C Screen Current	150	ma.
D-C Grid Current	16	ma.
Driving Power	0.7	approx. ma.
Power Output	135	approx. watts
† total effective grid-circuit resistance that will give 30000 ohms. ‡ obtained from fixed supply, modulated simultaneously with plate voltage.		
R-F POWER AMPLIFIER & OSCILLATOR - Class C Telephony		
Key-down conditions per tube without modulation		
D-C Plate Voltage	2000 max.	volts
D-C Screen Voltage (Grid #2)	400 max.	volts
D-C Grid Voltage (Grid #1)	-300 max.	volts
D-C Plate Current	180 max.	ma.
D-C Screen Current	25 max.	ma.
D-C Grid Current	260 max.	ma.
Plate Input	22 max.	watts
Screen Input	100 max.	watts
Plate Dissipation		
D-C Plate Voltage	1250	volts
D-C Screen Voltage	1500	volts
* , †, ‡: see end of tabulation.		

813 TRANSMITTING BEAM POWER AMPLIFIER

(continued from preceding page)		
D-C Screen Voltage	300	volts
D-C Grid Voltage	42000	ohms
Peak R-F Grid Voltage	160	volts
Peak A-F Grid Voltage	8500	ohms
Beam-Forming Plate Voltage	0	volts
D-C Plate Current	145	ma.
D-C Screen Current	180	ma.
D-C Grid Current	23	ma.
Driving Power	1	approx. watt
Power Output	155	approx. watts
* Modulation essentially negative may be used if the positive peak of the audio-frequency envelope does not exceed 15% of the carrier component.		
† Obtained by grid leak or other self- or fixed-bias method.		
‡ Preferably obtained from separate source or potentiometer, although series resistor connected to the filament supply.		
* Circuit operated on a.c., or to the negative end of filament operated on d.c. filament supply. If d.c. is used, the stated voltages should be decreased by 7 volts.		
o At crest of audio-frequency cycle with modulation factor of 1.0.		
OPERATION AT HIGH FREQUENCIES		
Maximum permissible percentage of maximum rated plate voltage and plate input		
FREQUENCY (Mc)	30	45
TELEPHONY	100% Class B Grid Mod.	85
	100% Class C Grid Mod.	87
TELEGRAPHY	Class C	87
	Class C	75
	Class C	50
	Class C	50

12SL7-GT

Except for heater rating, the electrical characteristics of the 12SL7-GT are the same as the 6SL7-GT shown below. The heater rating of the 12SL7-GT is 12.6 volts 0.15 amp.

6SL7-GT

TWIN-TRIODE AMPLIFIER

Heater <sup>a</sup>	Coated Unipotential Cathodes	a-c or d-c volts
Voltage	6.3	
Current	0.3	amp.
Direct Interelectrode Capacitances (Approx.) <sup>b</sup>		
	$F_1$ triode unit $F_2$ triode unit $F_2$	
Grid to Plate	2.8	2.8 pF
Grid to Cathode	3.0	3.4 pF
Plate to Cathode	3.8	3.2 pF
Plate to Plate		
Grid to Grid	0.4	0.4 pF
Grid $T_2$ to Plate $T_1$	0.65	0.65 pF
Grid $T_2$ to Plate $T_1$	0.13	0.13 pF
Maximum Overall Length		3-5/16"
Maximum Seated Height		2-3/4"
Maximum Diameter		1-5/16"
Bulb		T-9
Base		Intermediate Shell Octal 8-Pin
Pin 1 - Grid $T_2$		Pin 5 - Plate $T_1$
Pin 2 - Plate $T_2$		Pin 6 - Cathode $T_1$
Pin 3 - Cathode $T_2$		Pin 7 - Heater
Pin 4 - Grid $T_1$		Pin 8 - Heater
Mounting Position		Any

BOTTOM VIEW (8BD)

For convenience, one triode unit is identified as  $F_1$ ; the other as  $F_2$

AMPLIFIER - Each Unit

Plate Voltage	250 max. volts
Grid Voltage	0 min. volts
Plate Dissipation	1 max. watt
Characteristics - Class $A_1$ Amplifier:	
Plate	250 volts
Grid	-2 volts
Amp. Fact.	70
Plate Res.	44000 ohms
Transcond.	1600 $\mu$ mhos
Plate Cur.	2.3 ma.

<sup>a</sup> In circuits where the cathode is not directly connected to the heater, the potential difference between heater and cathode should be kept as low as possible.

<sup>b</sup> With close-fitting shield connected to cathode.

12SA7, 12SA7-GT/G

Except for heater rating, the electrical characteristics of the 12SA7, 12SA7-GT/G are the same as the 6SA7, 6SA7-GT/G shown below. The heater rating of the 12SA7, 12SA7-GT/G is 12.6 volts 0.15 amp.

6SA7, 6SA7-GT/G  
PENTAGRID CONVERTER

(continued from preceding page)

Characteristics	Self-excitation	Separate Excitation
Plate Voltage	100	100
Grids #2 & #4 Volt.	100	100
Grid #3 (Control) Volt.	0	-2
Grid #1 Resistor	20000	20000
Plate Res. (Approx.)	0.5	1.0
Conversion Transcond.	425	450
(Approx.)	2	2
Plate Current	3.3	3.3
Grids #2 & #4 Current	8.5	8.5
Grid #1 Current	0.5	0.5
Total Cathode Current	12.3	12.3

Note: The transconductance between Grid #1 and Grids #2 & #4 connected to plate (not oscillating) is approximately 4500  $\mu$ hos under the following conditions: Grids #1, #3, and shell at 0 volts; Grids #2 & #4 and plate at 100 volts.

\* Characteristics are approximate only and are shown for a Hartley circuit with a feedback of approximately 2 volts peak in the cathode circuit.  $\dagger$  With Grid #3 bias of -35 volts.

**TYPICAL SELF-EXCITED CONVERTER CIRCUIT FOR TYPE 6SA7**

AVC  
B+ PASS COND.  
TUNING COND.  
OSC. COIL

$C_1 = 50 \mu\text{F}$   
 $C_2 = 50 \mu\text{F}$   
 $C_3 = 50 \mu\text{F}$   
 $C_4 = 50 \mu\text{F}$   
 $C_5 = 50 \mu\text{F}$   
 $C_6 = 50 \mu\text{F}$

$N_1 = \text{TOTAL TURNS IN OSC. COIL}$   
 $N_2 = \text{TURNS IN AUDIO COIL}$   
 $R_1 = 20000 \text{ OHMS}$   
 $R_2 = 20000 \text{ OHMS}$   
 $R_3 = 20000 \text{ OHMS}$   
 $R_4 = 20000 \text{ OHMS}$   
 $R_5 = 20000 \text{ OHMS}$   
 $R_6 = 20000 \text{ OHMS}$

The license extended to the purchaser of tubes appears in the License Notice accompanying the tubes. Information contained herein is furnished without assuming any obligations.

6SA7, 6SA7-GT/G  
PENTAGRID CONVERTER

Heater Voltage	Coated Unipotential Cathode	a-c or d-c volts
6.3		6.3
0.3		0.3
Direct Inter-electrode Capacitances:		6SA7-07/2
Grid #5 to All Other Electrodes (A-F Input)	9.5 $\mu$	11 $\mu$
Plate to All Other Electrodes (Mixer Output)	1.4 $\mu$	1.4 $\mu$
Grid #1 to All Other Electrodes (Osc. Input)	1.4 $\mu$	0.4
Grid #3 to Plate	0.15 max. $\mu$	0.5 max. $\mu$
Grid #5 to Grid #1	0.15 max. $\mu$	0.4 max. $\mu$
Grid #1 to Plate	0.06 max. $\mu$	0.2 max. $\mu$
Grid #1 to Shell, Grid #5, and All Other Electrodes except Cathode	4.4	-
Grid #1 to All Other Electrodes except Cathode & Grid #5	2.6	5
Grid #1 to Cathode	-	3
Cathode to Shell, Grid #5, and All Other Electrodes except Grid #1	5	14
Cathode and Grid #5 to All Other Electrodes except Grid #1	2-5/8"	3-5/16"
Maximum Overall Length	2-1/16"	2-3/4"
Maximum Seated Height	1-5/16"	1-5/16"
Maximum Diameter		T-9
Bulb		Intermed. Sh.
Base		Octal 8-Pin
Pin 1 - 6SA7, Shell, Grid #5		
Pin 2 - Heater		
Pin 3 - Plate		
Pin 4 - Grids #2 & #4		
Pin 5 - Grid #1		
Pin 6 - 6SA7, Cathode		
Pin 6 - 6SA7-GT/G, Cathode & Grid #5		
Pin 7 - Heater		
Pin 8 - Grid #3		
Mounting Position		Any

Maximum and Minimum Ratings Are Design-Center Values

**CONVERTER SERVICE**

Plate Voltage	300 max. volts
Grids #2 & #4 Voltage	100 max. volts
Grids #2 & #4 Supply Voltage	300 max. volts
Grid #3 Voltage	0 min. volts
Plate Dissipation	1.0 max. watt
Screen Dissipation	1.0 max. watt
Total Cathode Current	14 max. ma.

in circuits where the cathode is not directly connected to the heater, the potential difference between heater and cathode should be kept as low as possible.

▲ With shell connected to cathode.

▲ With external shield connected to cathode.

▲ For self-excited oscillator.

— Indicates a change.

**8. UNITED STATES - BRITISH GLOSSARY OF TERMS USED IN THIS HANDBOOK.**

UNITED STATES	BRITISH
Battery	Accumulator
Antenna	Aerial
Cap screw	Set screw
Fillister-head screw	Cheese-headed screw
Flat-head screw	Countersunk-head screw
Frequency Meter	Wavemeter
Ground	Earth
Radio	Wireless
Round-head screw	Cup-headed screw
Set-screw	Grub screw
Tube (vacuum)	Valve

**9. PHOTOGRAPHS.**

AN 08-30ART3-5

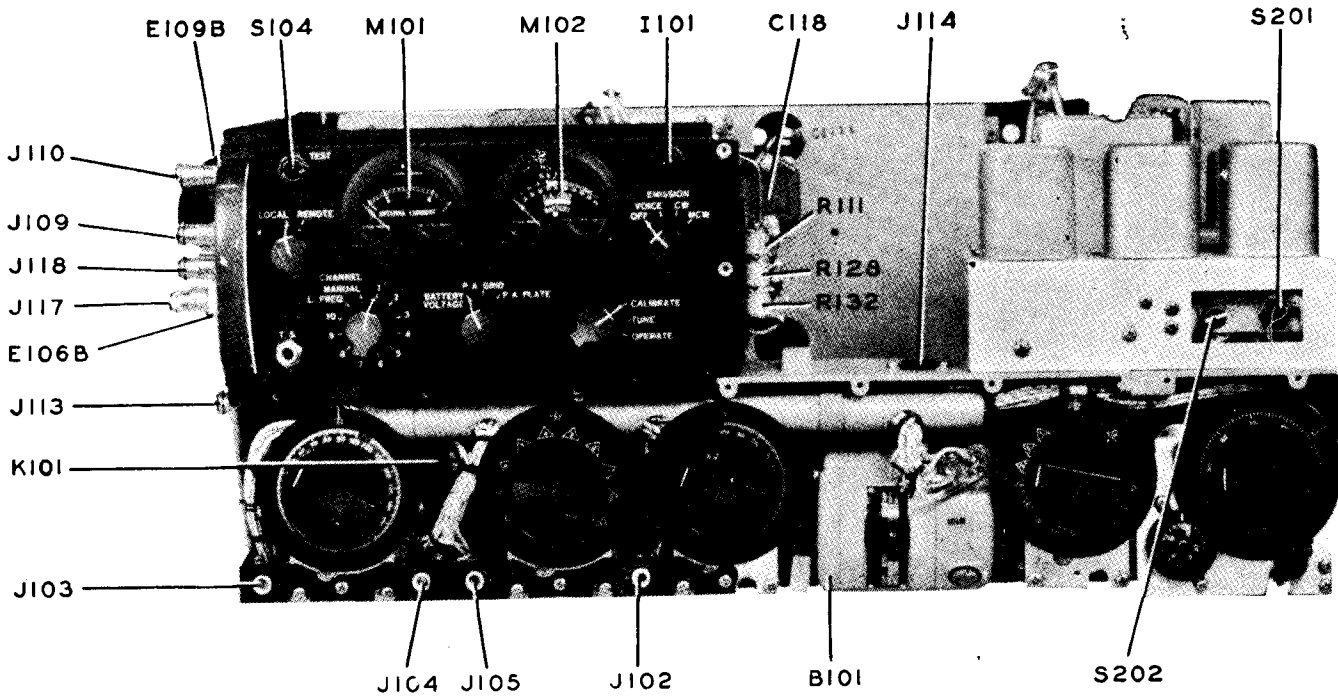

Figure 6-18. Type T-47/ART-13 Transmitter Unit—Front View Open

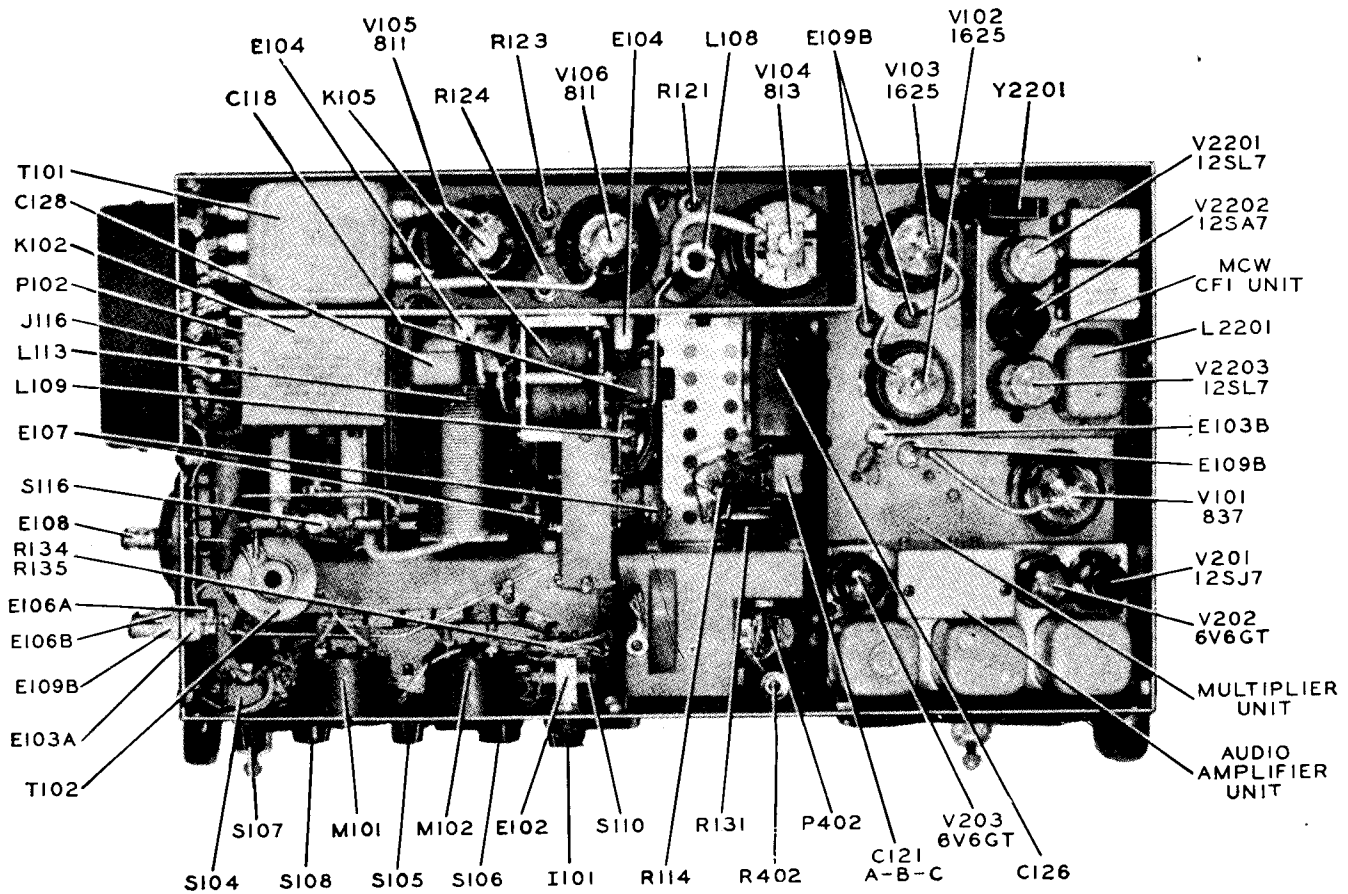

Figure 6-19. Type T-47/ART-13 Transmitter Unit—Top View Open

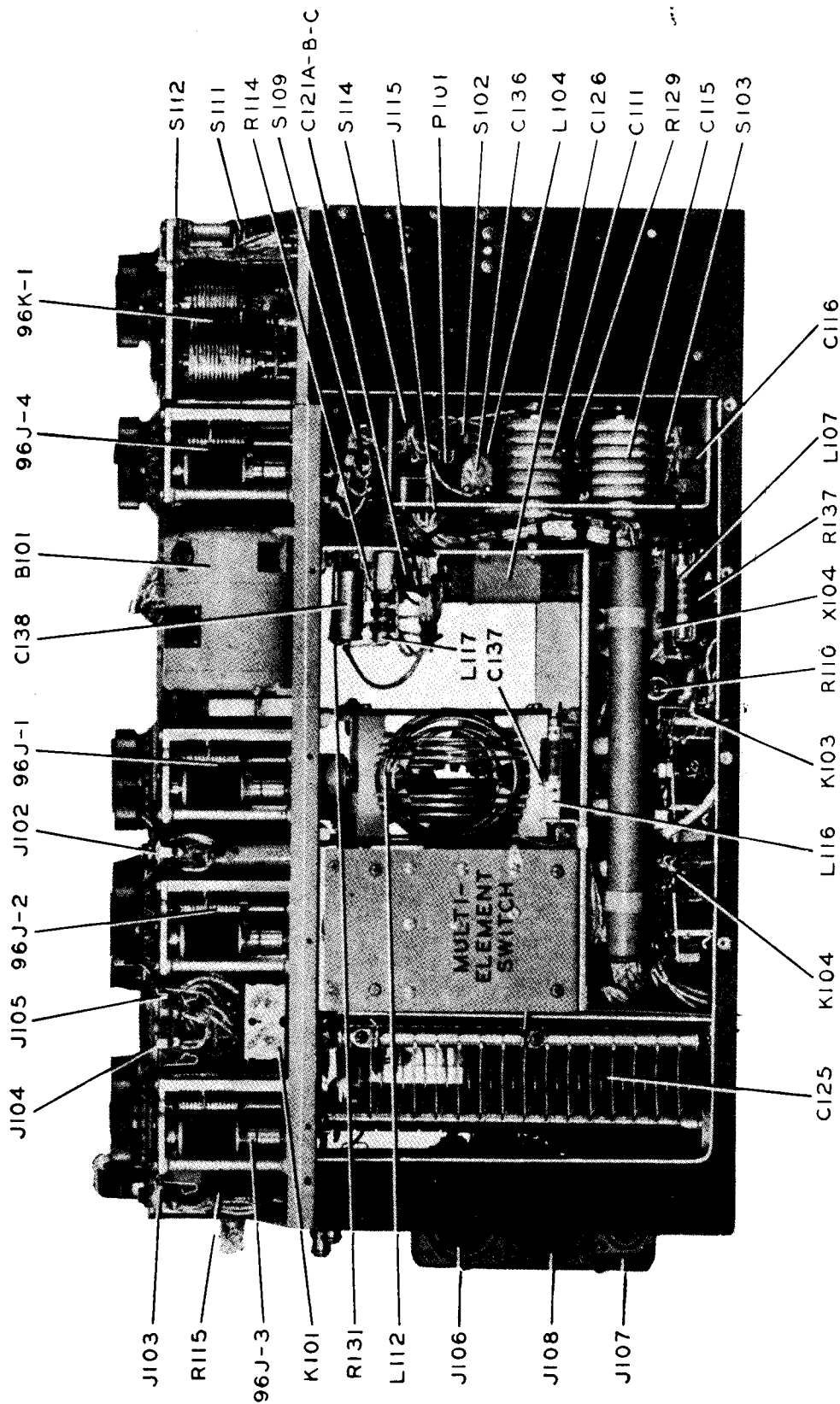

Figure 6-20. Type 7-47/ART-13 Transmitter Unit—Bottom View Open

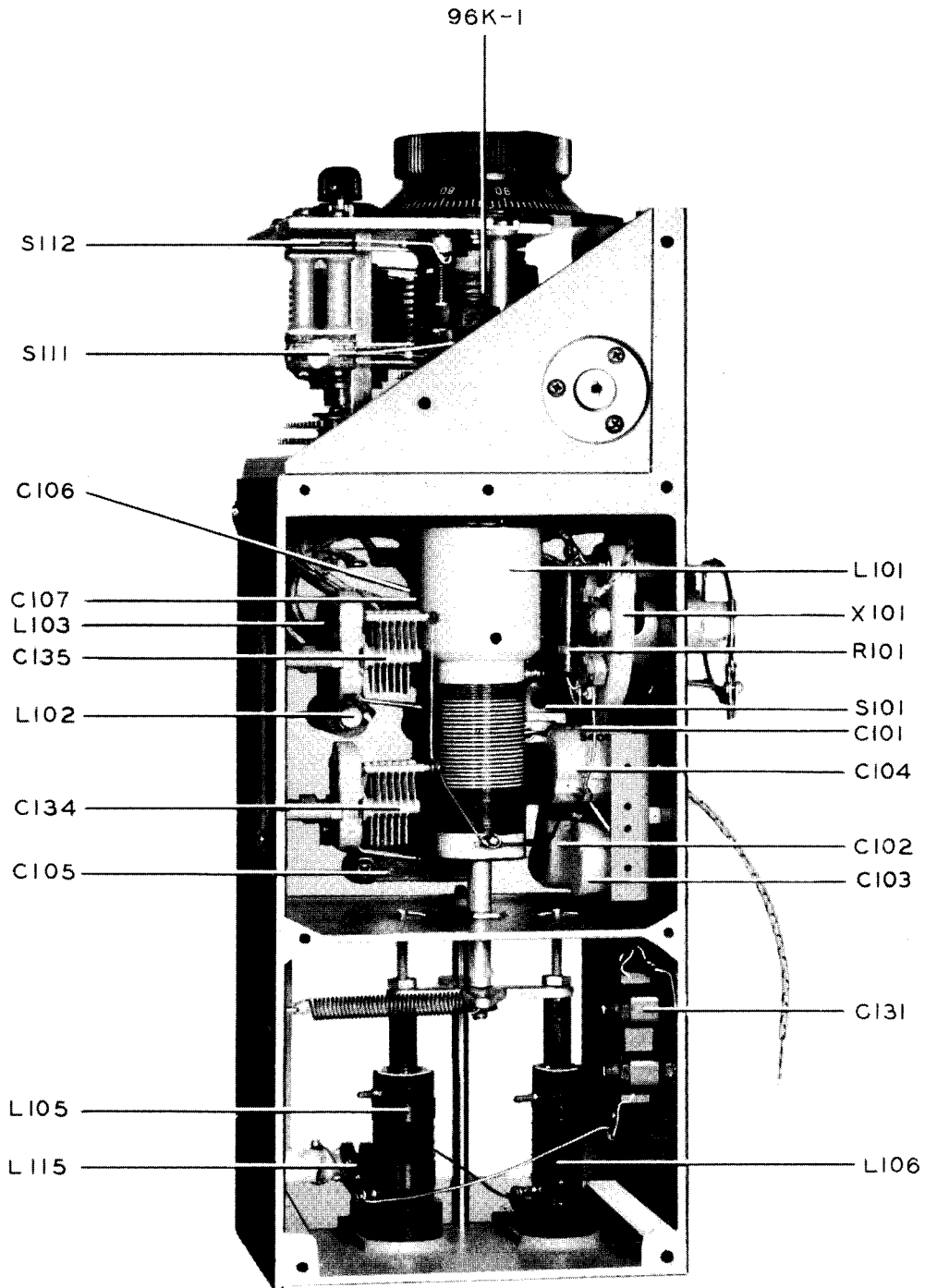

Figure 6-21. High Frequency Oscillator—Side View Open

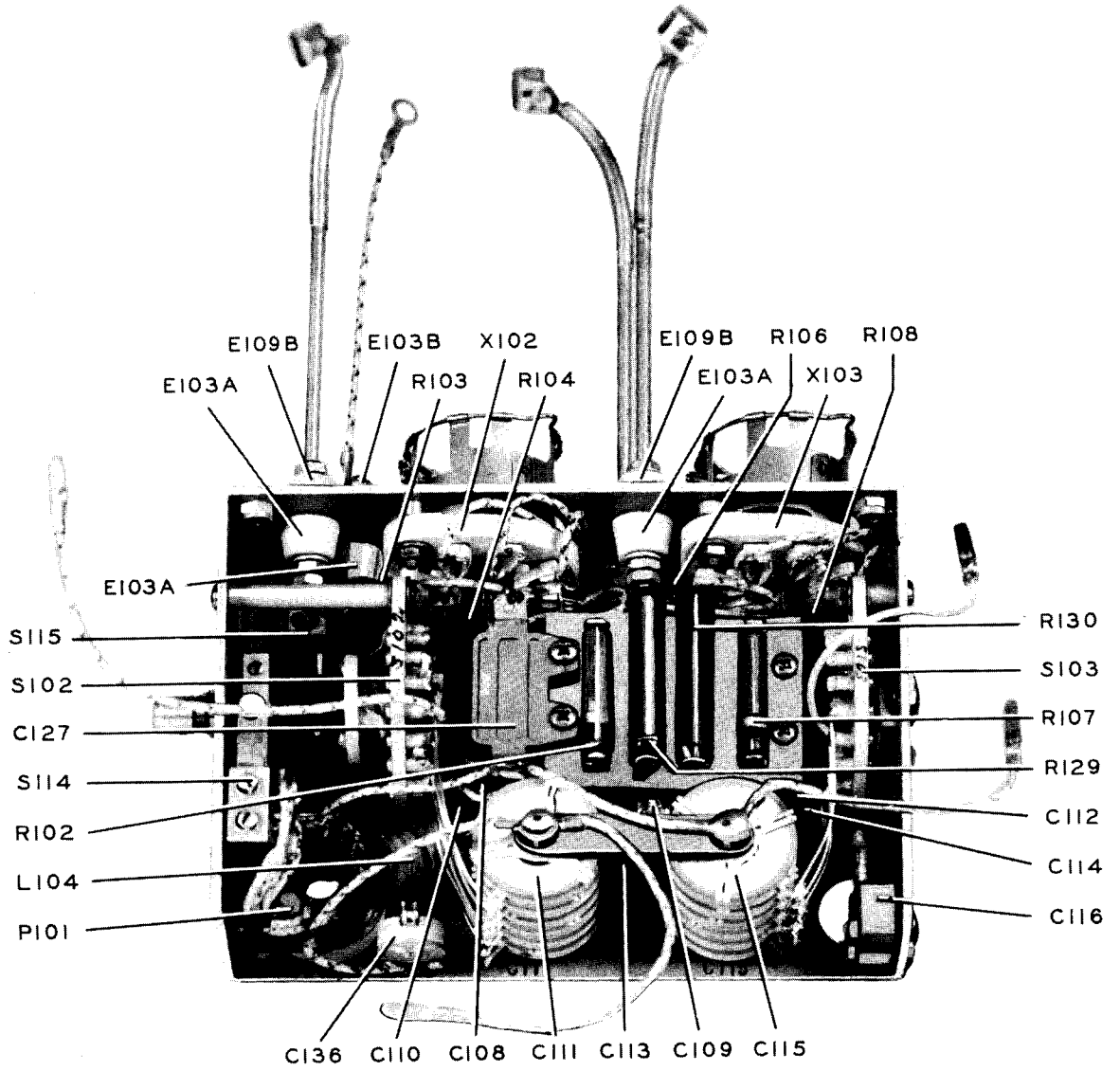

Figure 6-22. Frequency Multiplier—Side View Open



AN 08-30ART13-5

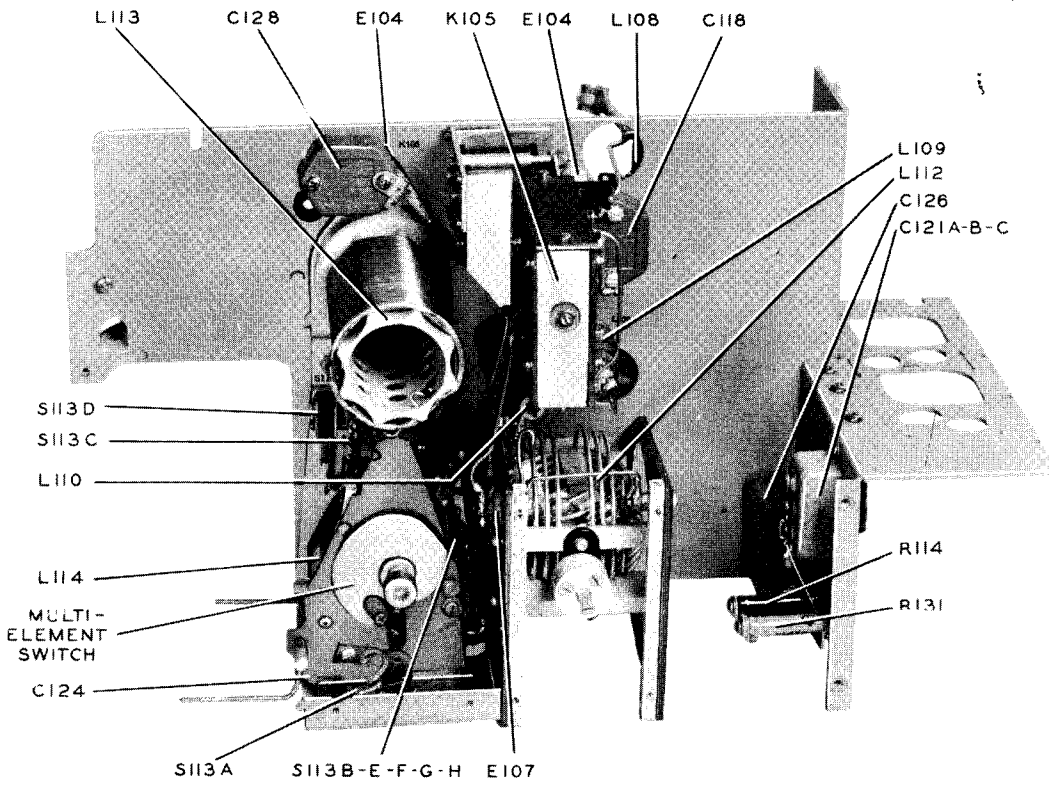

Figure 6-23. Fire Wall Assembly—Top View

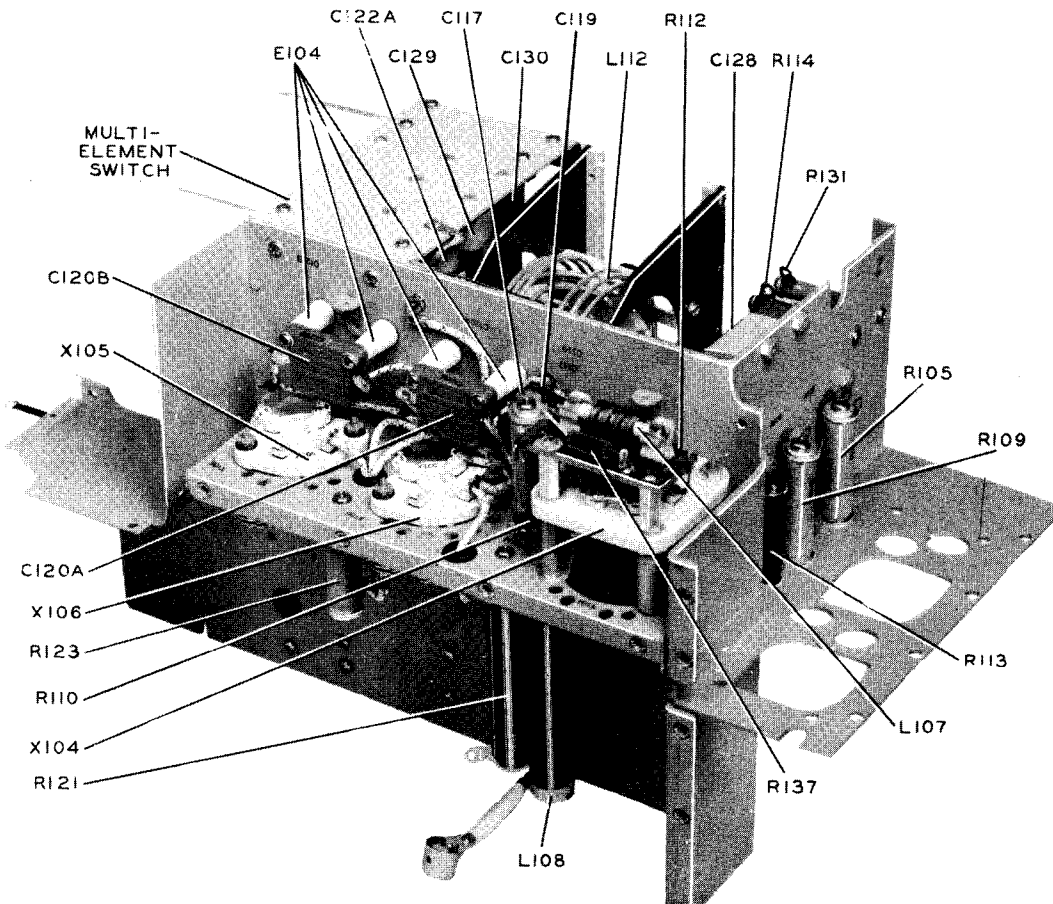

Figure 6-24. Fire Wall Assembly—Bottom View

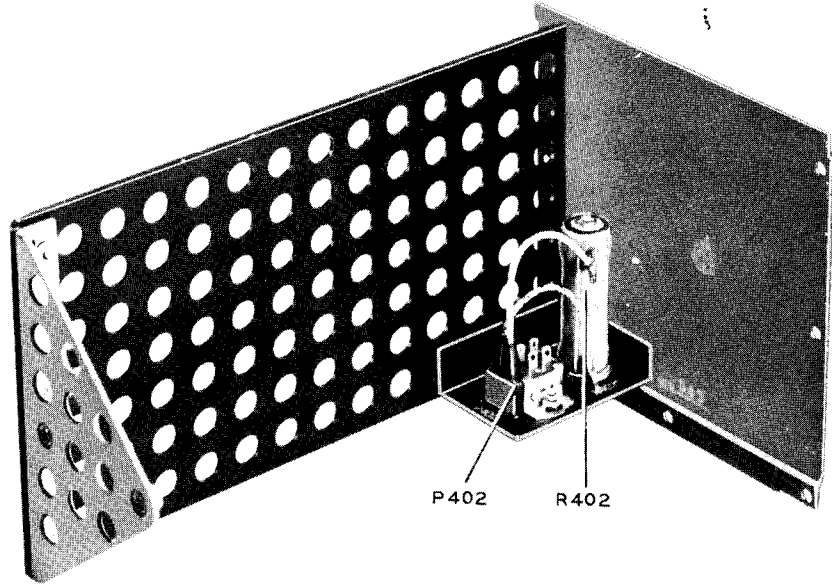

Figure 6-25. Type NX-128/ART-13 Dummy Low Frequency Oscillator Unit—  
Side View

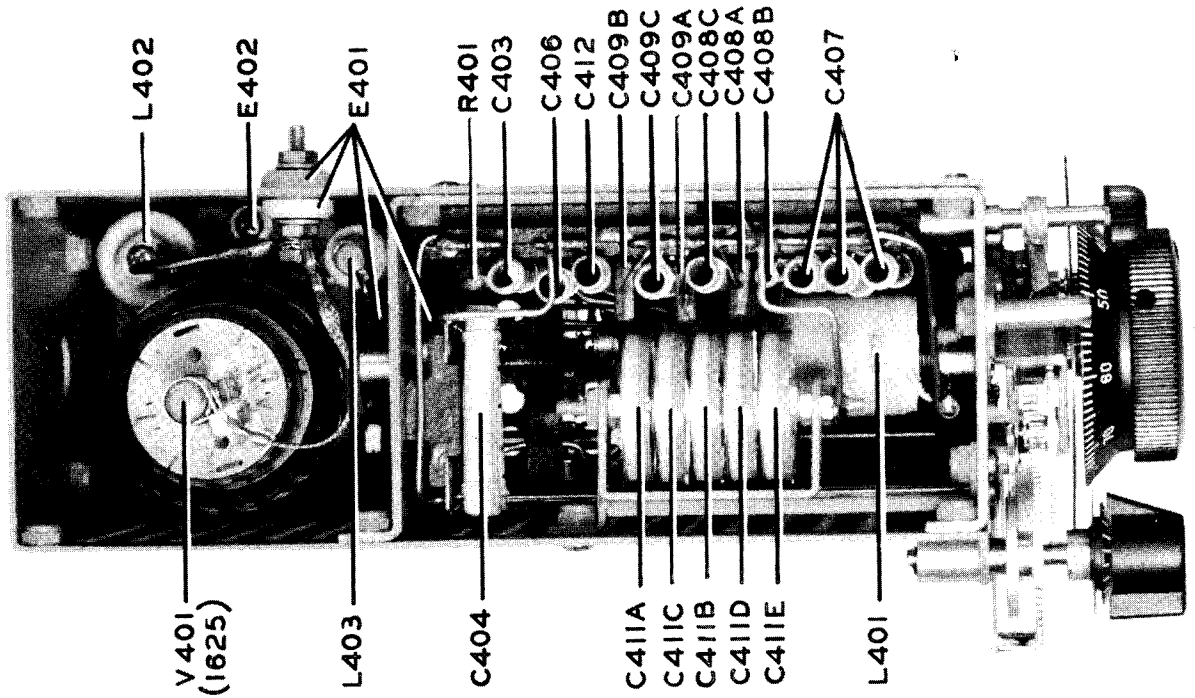

Figure 6-26. Type O-16/ART-13 Low Frequency Oscillator Unit—  
Top View Open

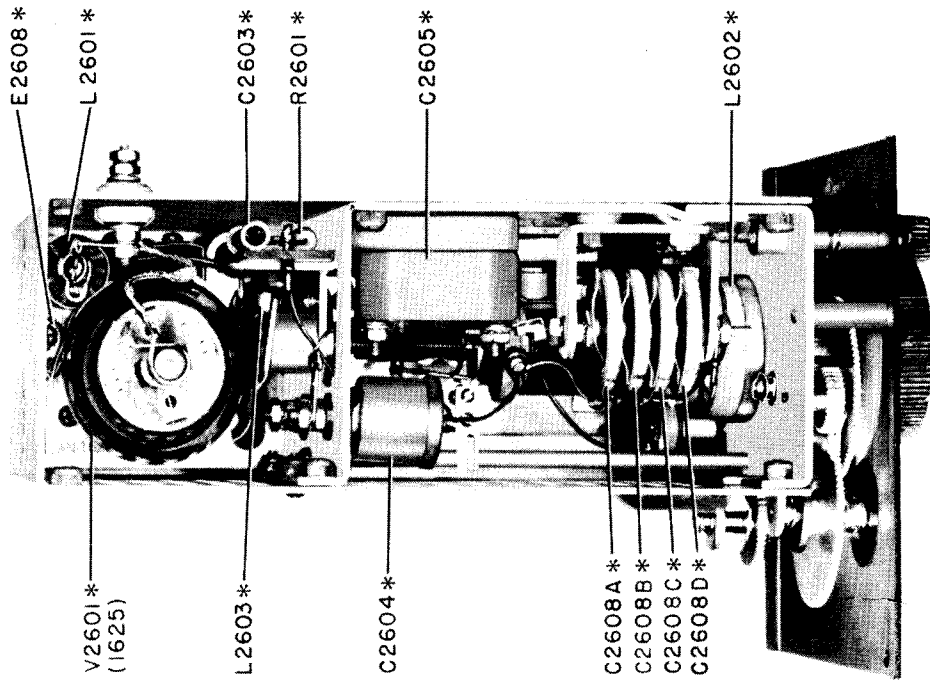

Figure 6-26A. Type O-17/ART-13A Low Frequency Oscillator Unit—  
Top View Open

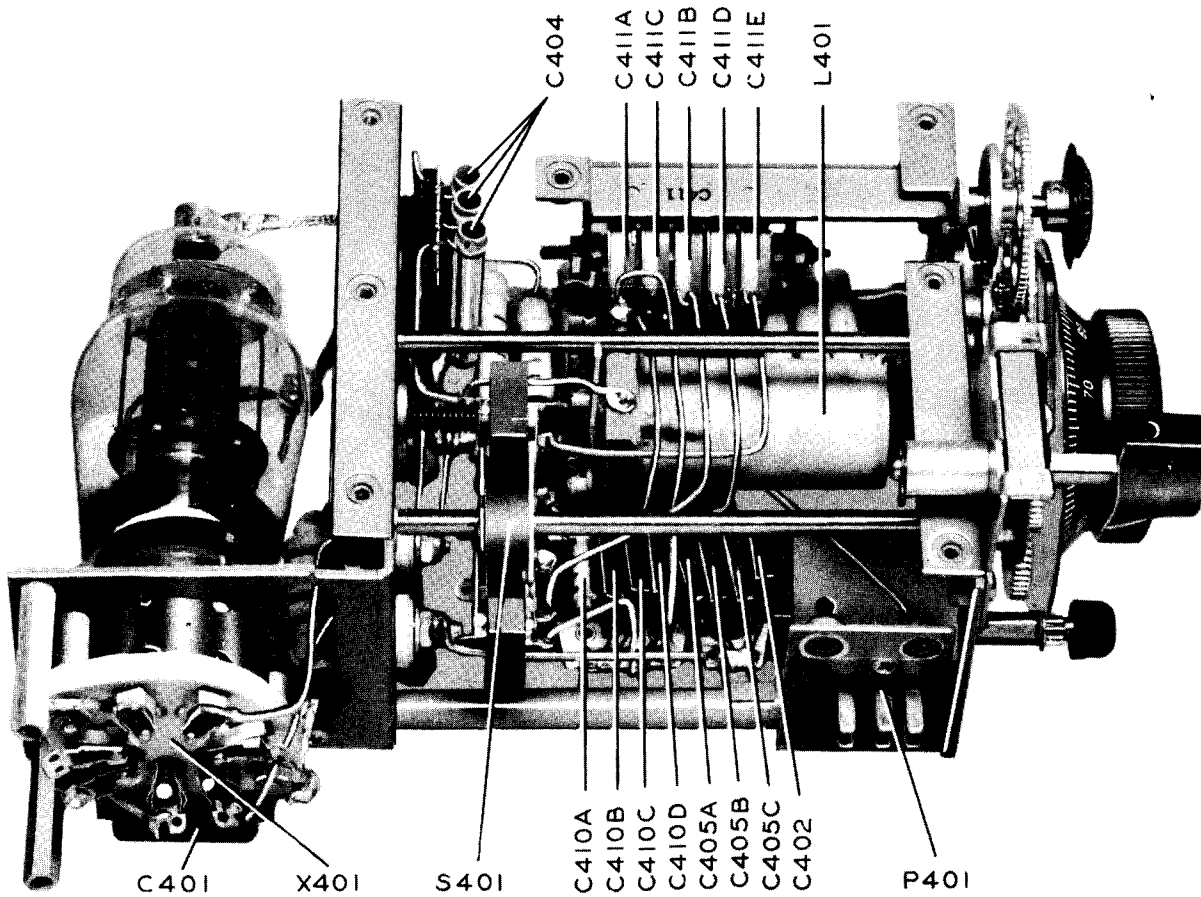

Figure 6-27. Type O-16/ART-13 Low Frequency Oscillator Unit—  
Bottom View Open

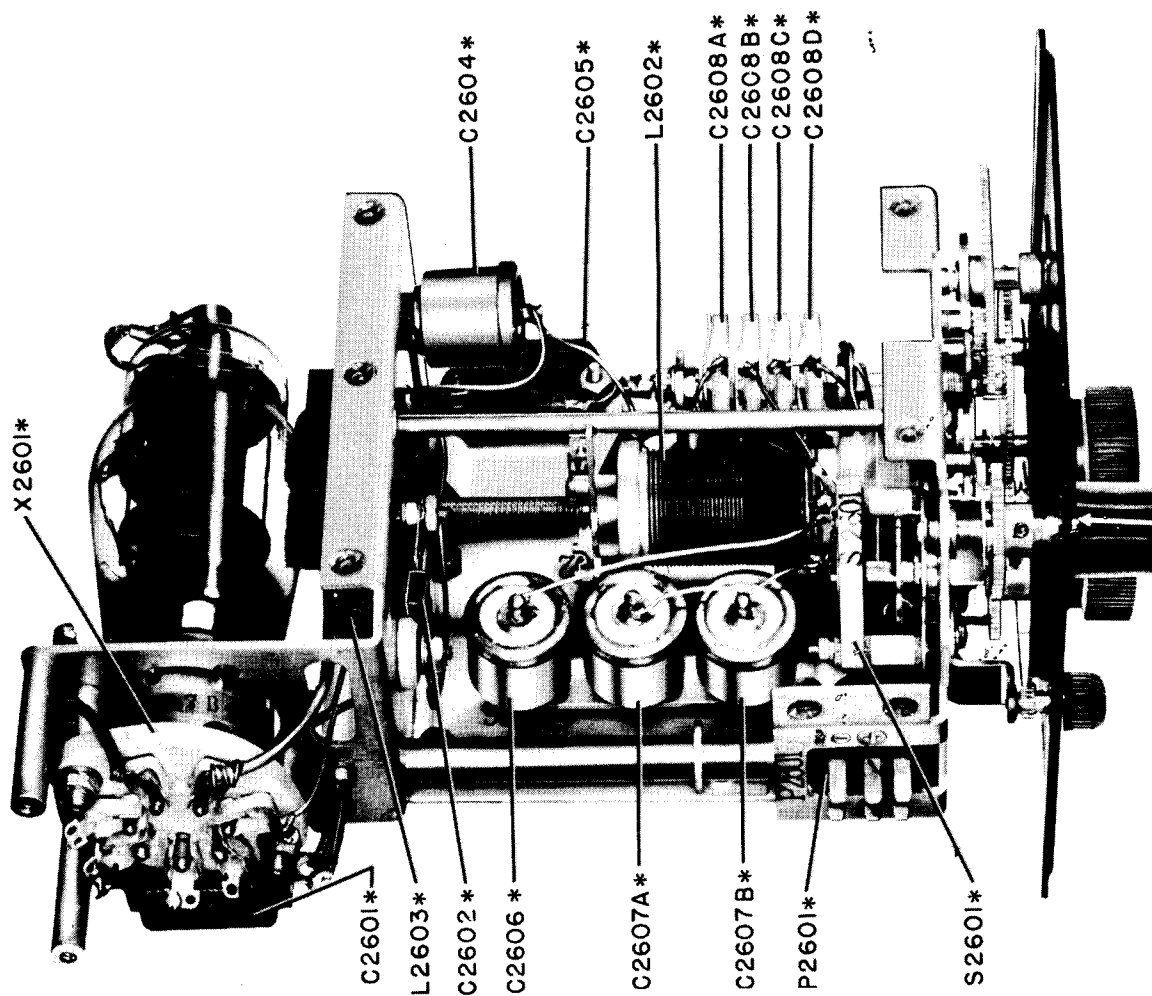

Figure 6-27A. Type O-17/ART-13A Low Frequency Oscillator Unit—  
Bottom View Open

AN 08-30ART13-5

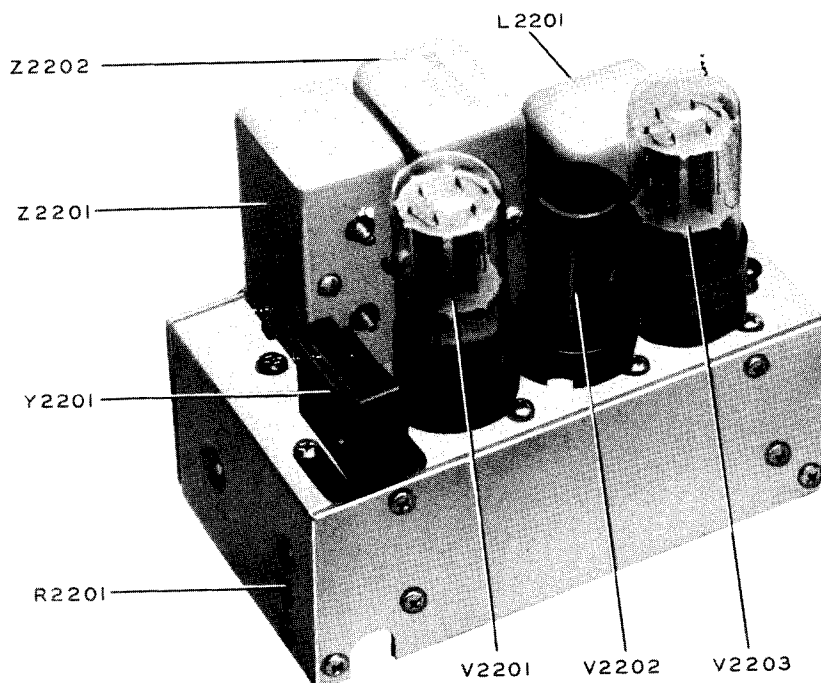

Figure 6-28. MCW-CFI Unit—Top View

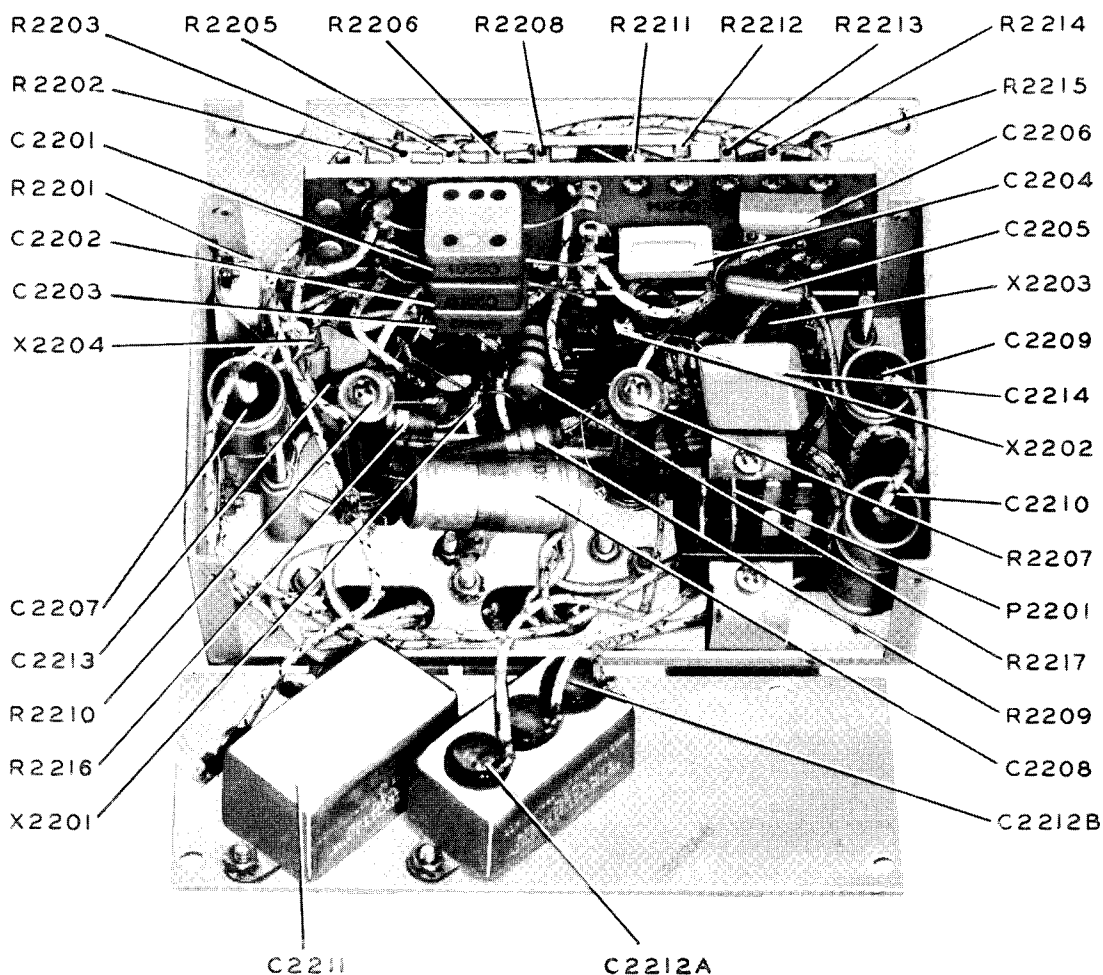

Figure 6-29. MCW-CFI Unit—Bottom View Open

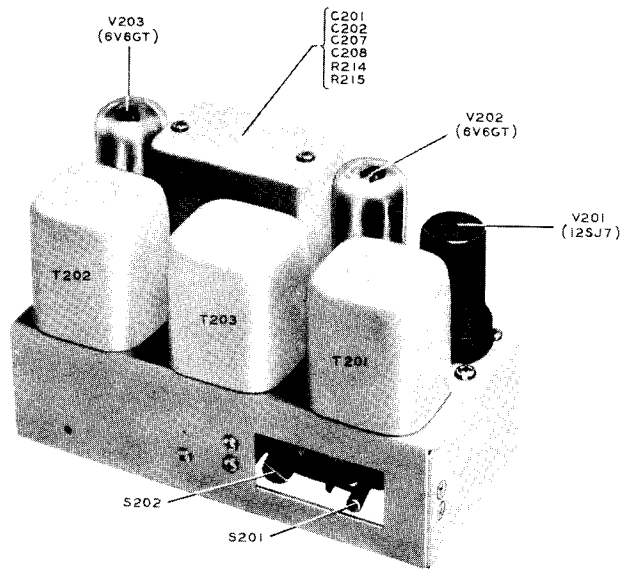

Figure 6-30. Audio Amplifier Unit—Top View

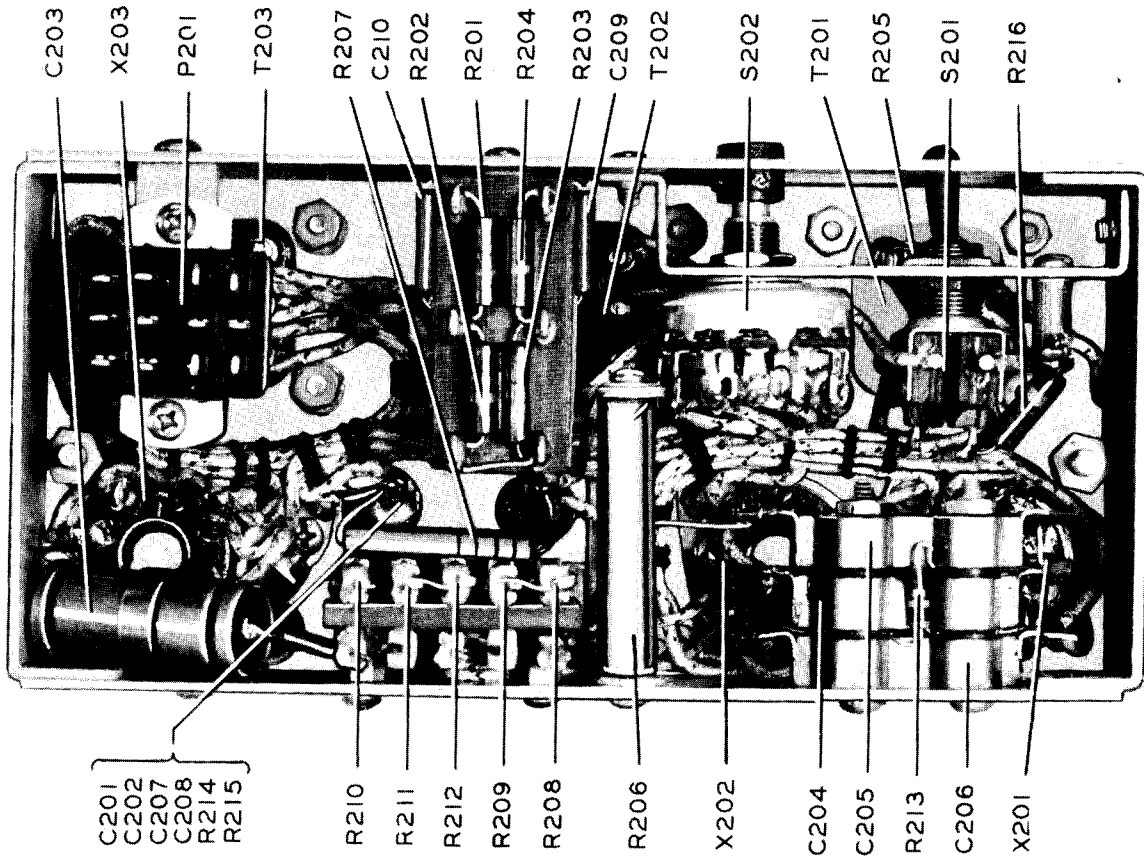

Figure 6-31. Audio Amplifier Unit—Bottom View

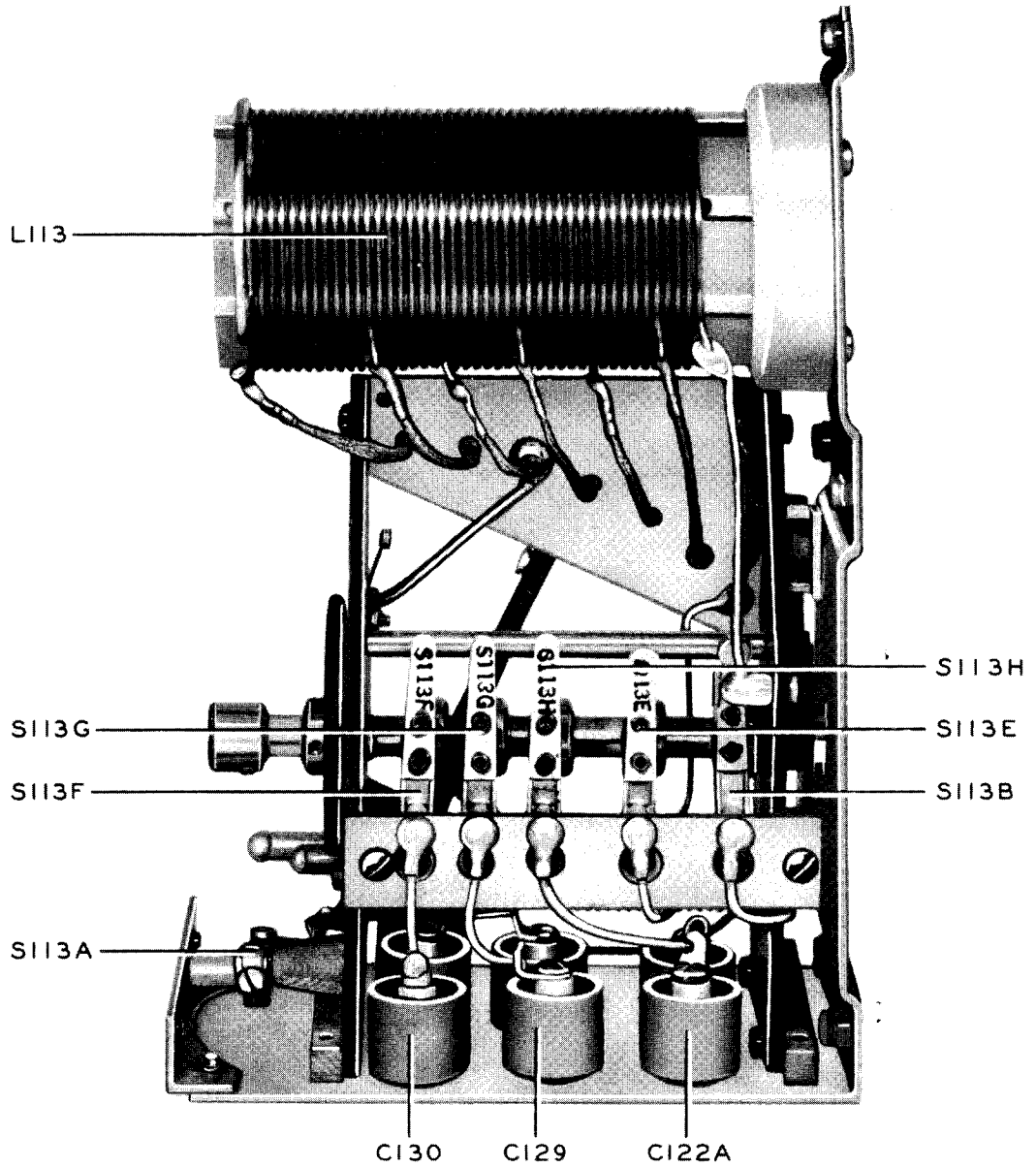

Figure 6-32. Multi-Element Switch—Right Side View

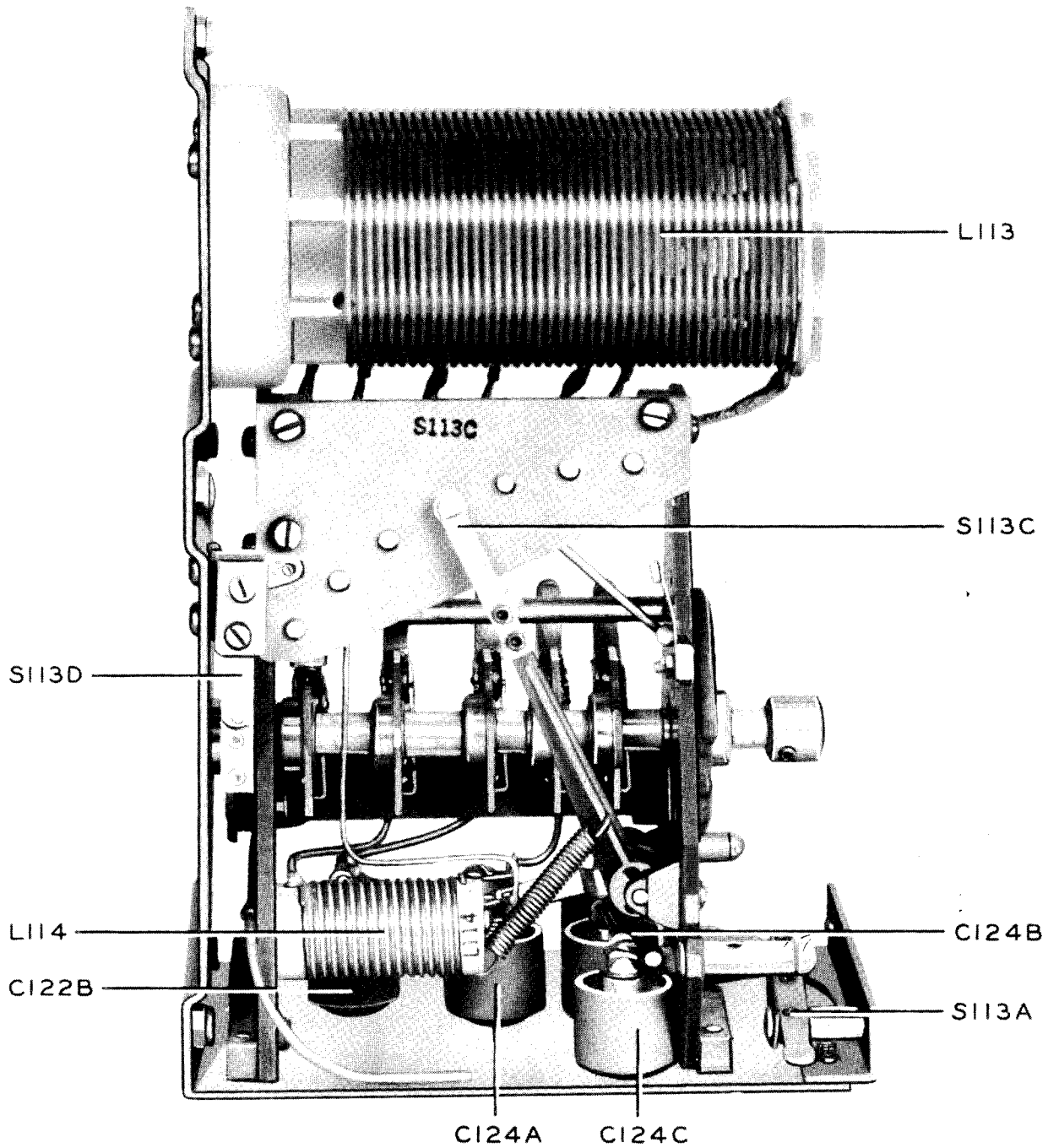

Figure 6-33. Multi-Element Switch—Left Side View



AN 08-30ART13-5

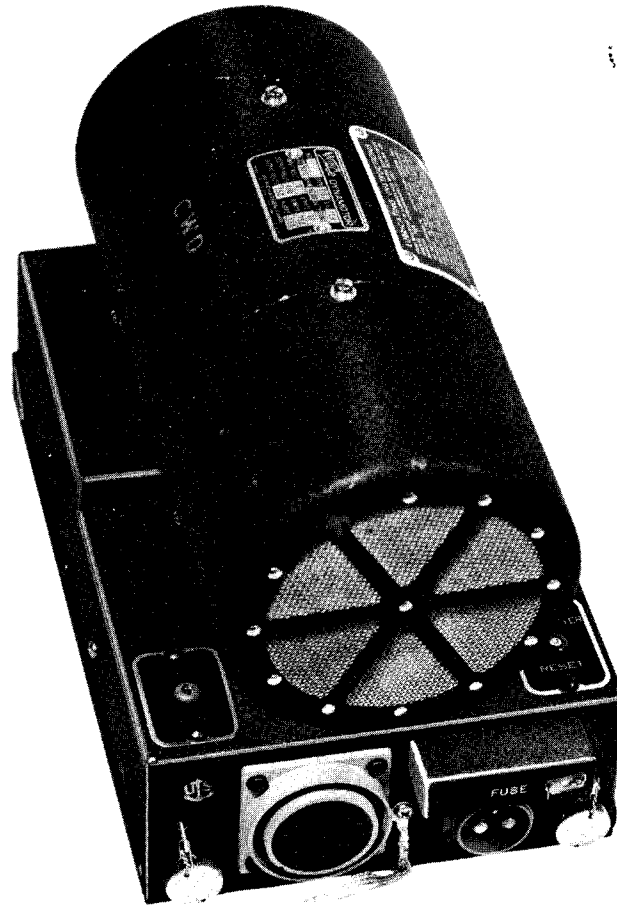

Figure 6-34. Type DY-12/ART-13 Dynamotor Power Unit—Top View

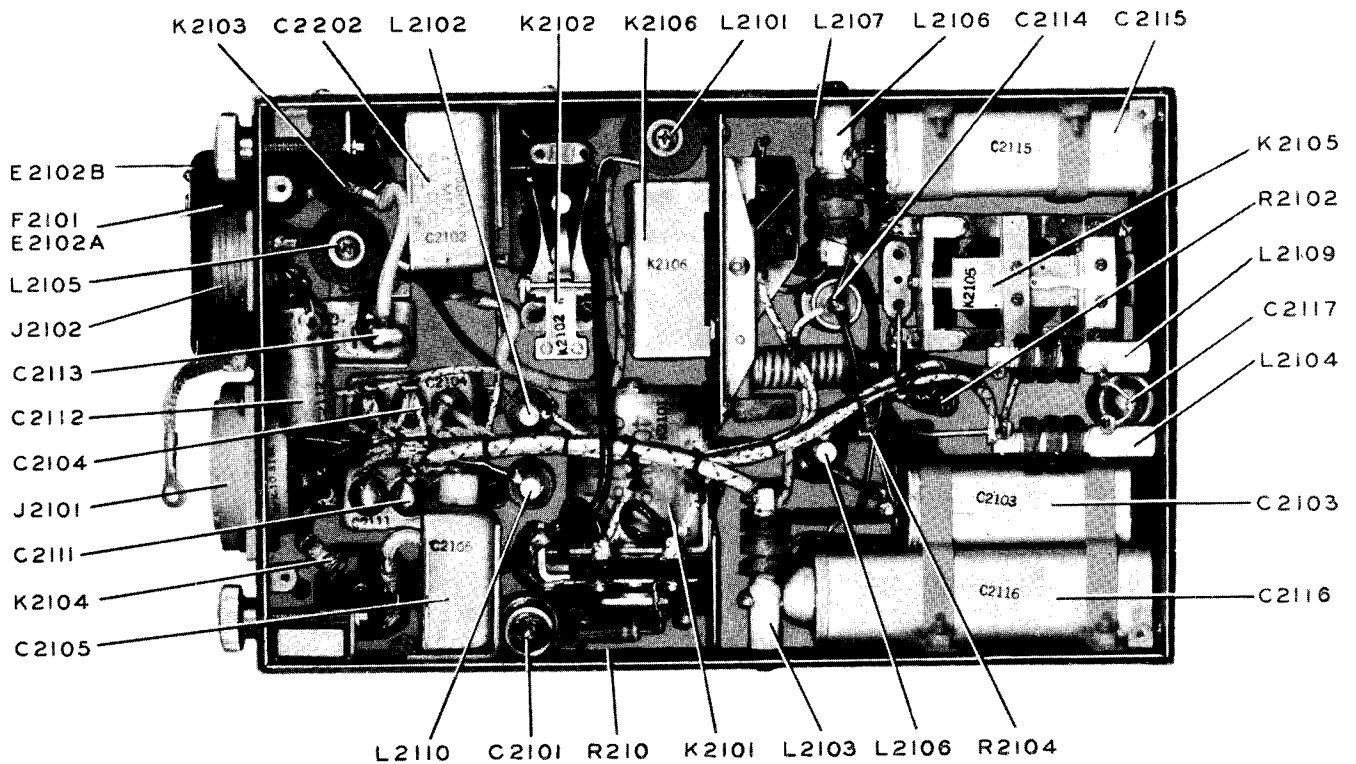

Figure 6-35. Type DY-12/ART-13 Dynamotor Power Unit—Bottom View Open

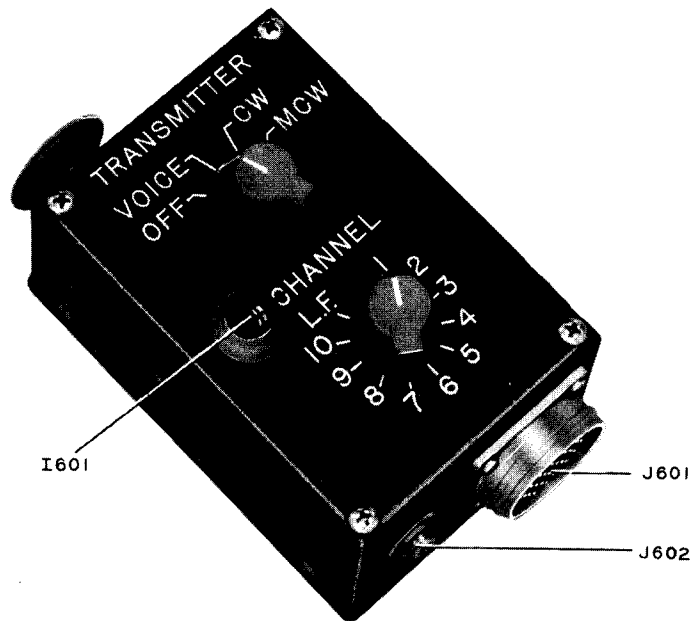

Figure 6-36. Type C-87/ART-13 Pilot's Control Unit—Front View

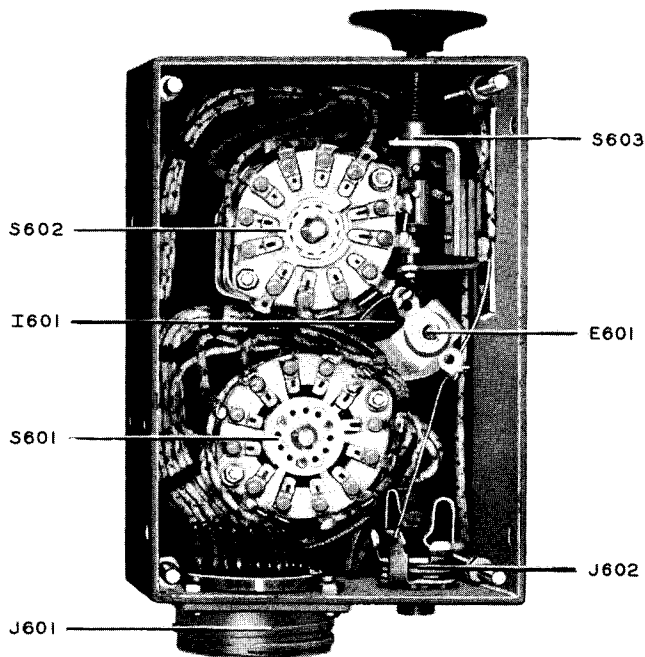

Figure 6-37. Type C-87/ART-13 Pilot's Control Unit—Rear View Open

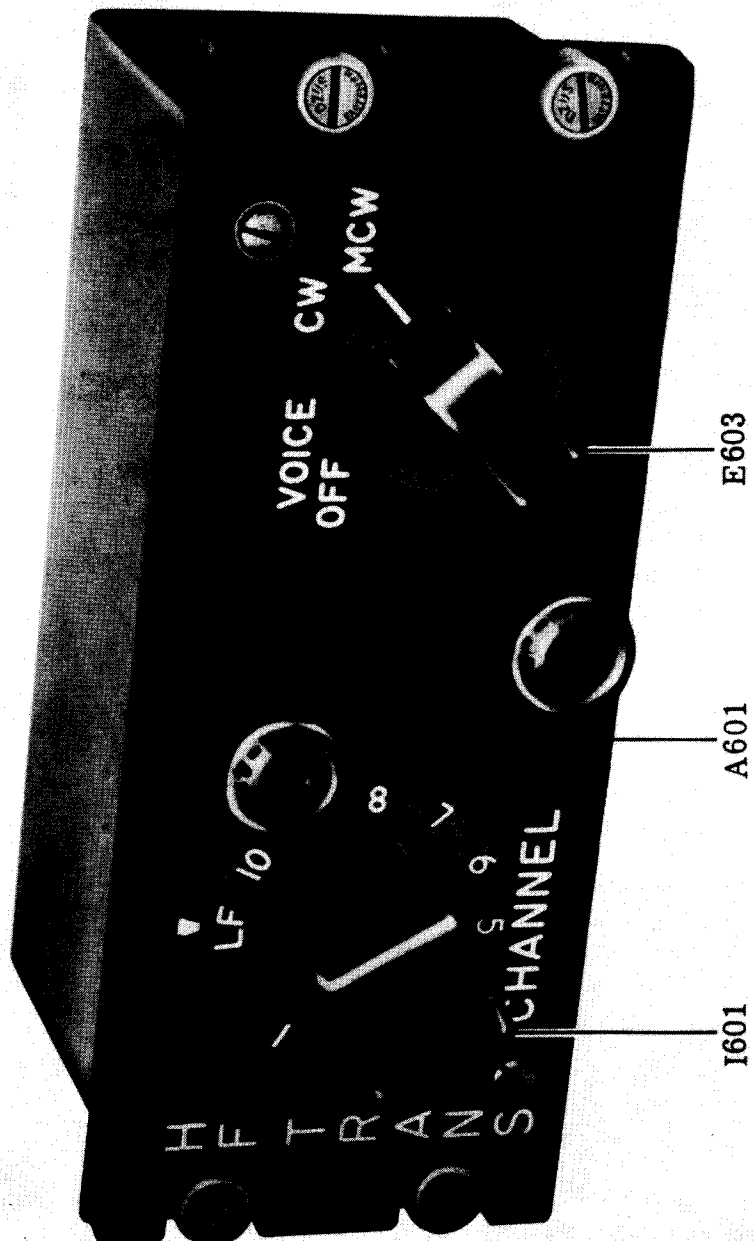

Figure 6-37A. Type C-740/ART-13 Pilot's Control Unit—Front View

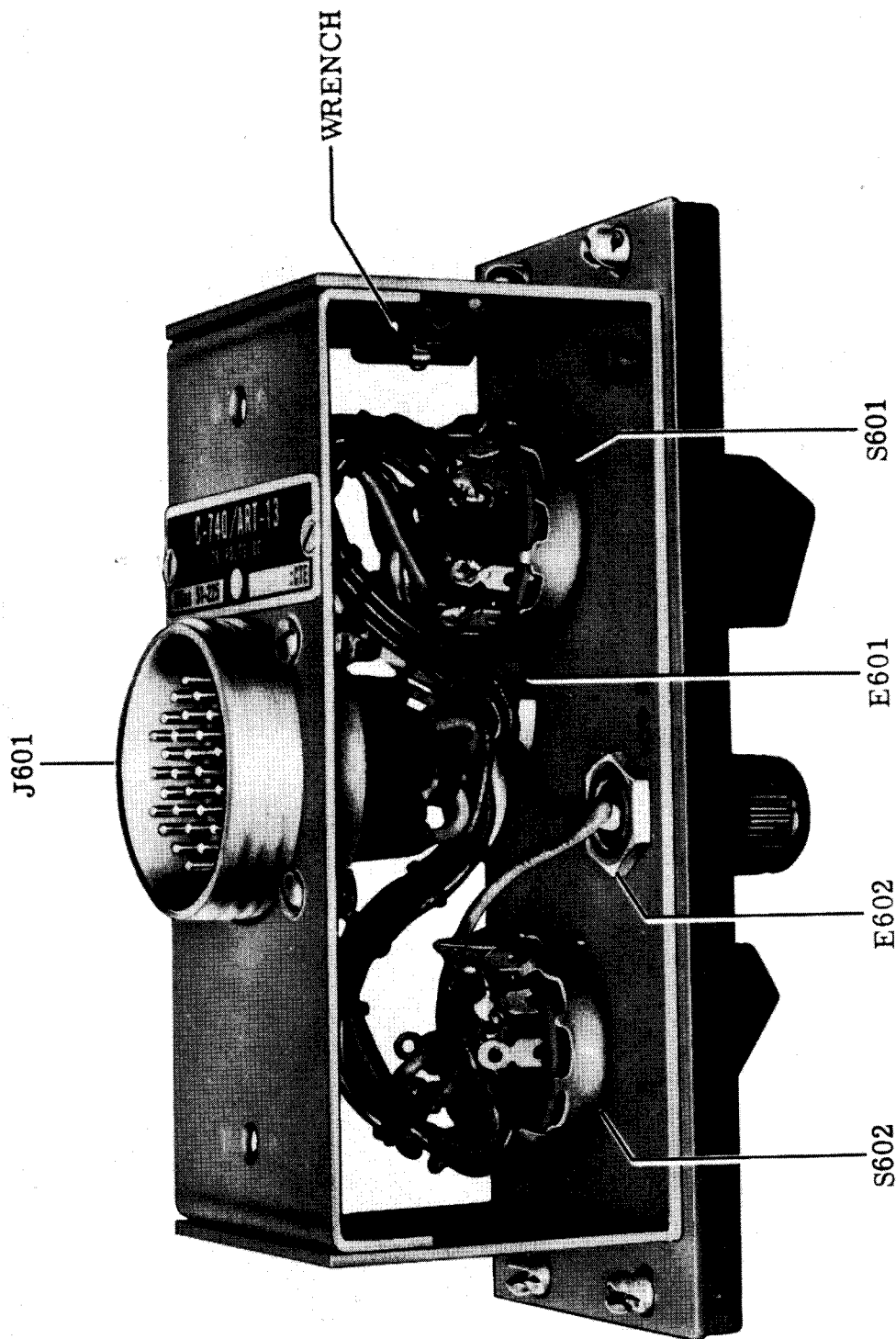

Figure 6-37B. Type C-740/ART-13 Pilot's Control Unit—Rear View

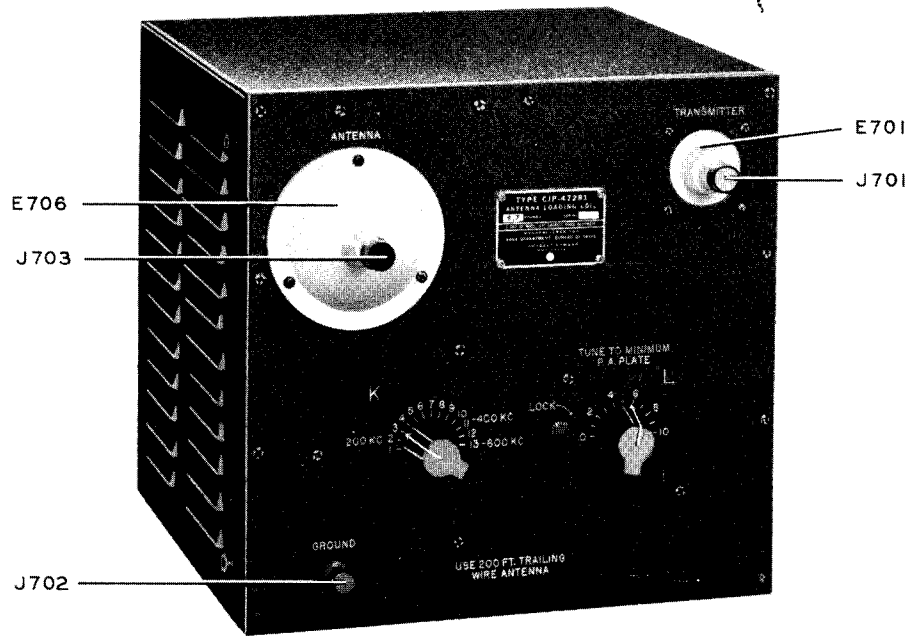

Figure 6-38. Type CU-25/ART-13 Antenna Loading Coil Unit—Front View

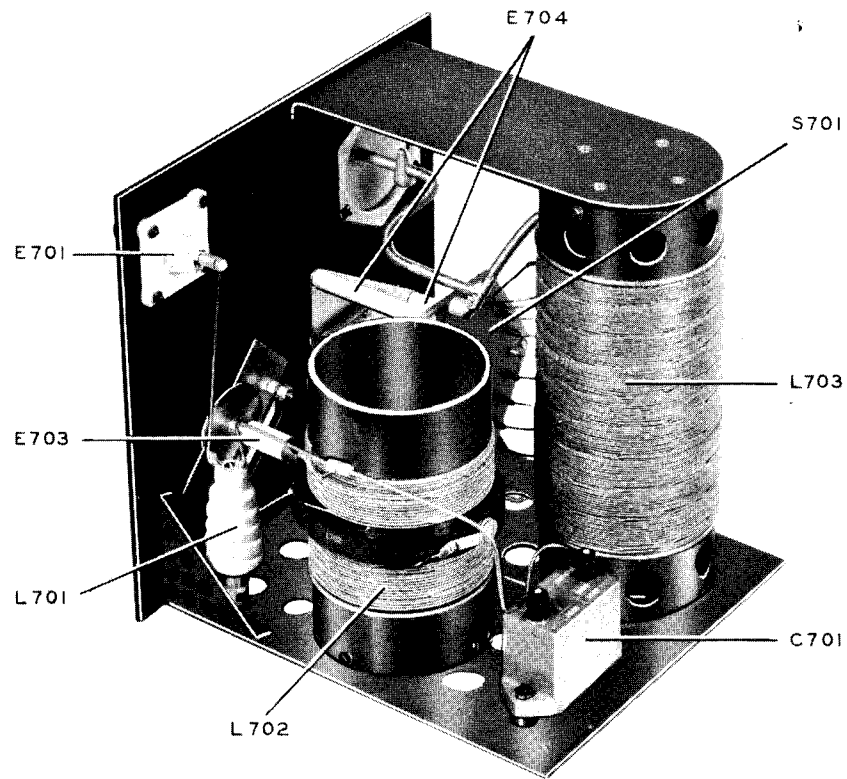

Figure 6-39. Type CU-25/ART-13 Antenna Loading Coil Unit—Open View

AN 08-30ART13-5



Figure 6-40. Type CU-26/ART-13 Antenna Loading Coil Unit—Front View

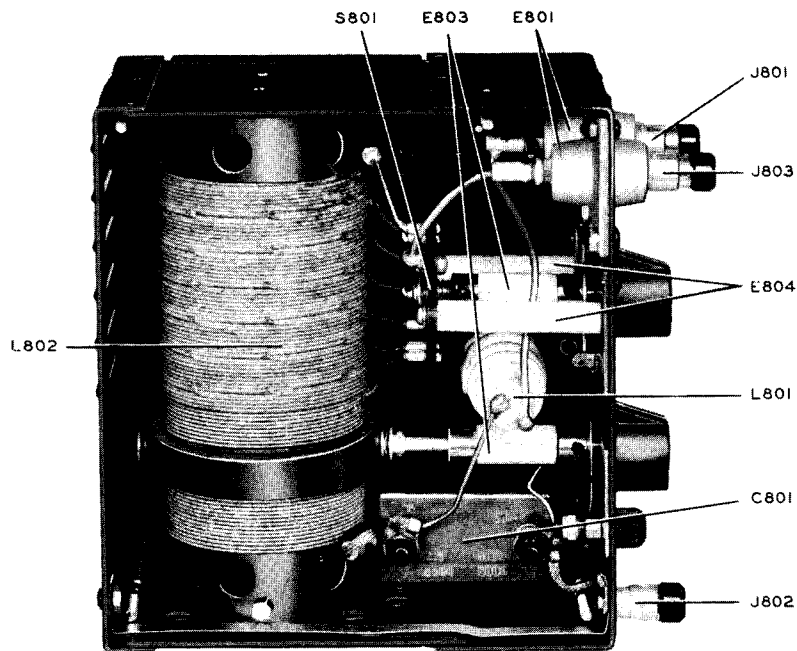

Figure 6-41. Type CU-26/ART-13 Antenna Loading Coil Unit—Inside View

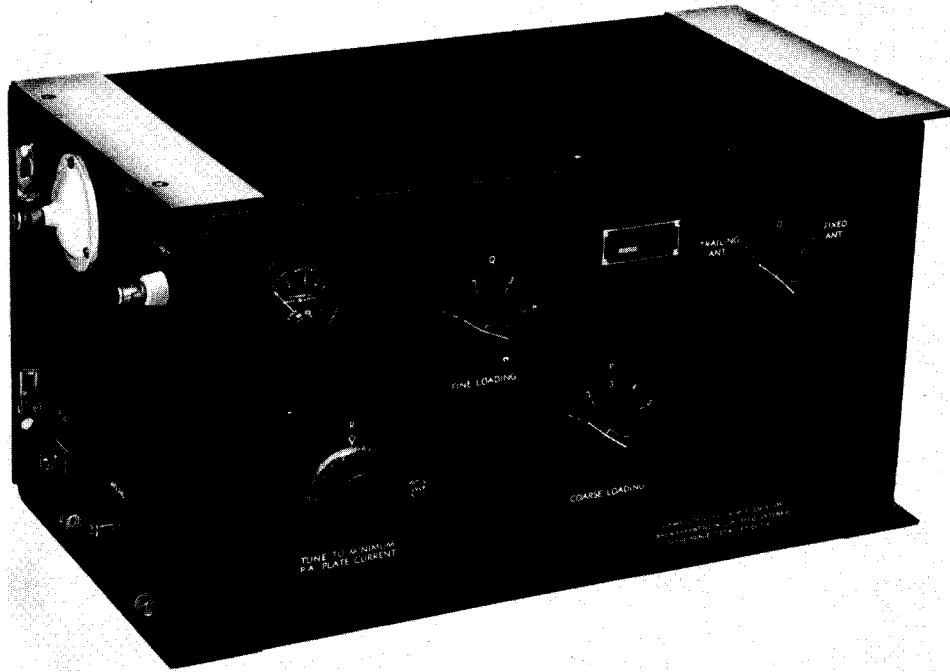

Figure 6-41A. Type CU-32/ART-13A Antenna Loading Coil—Front View

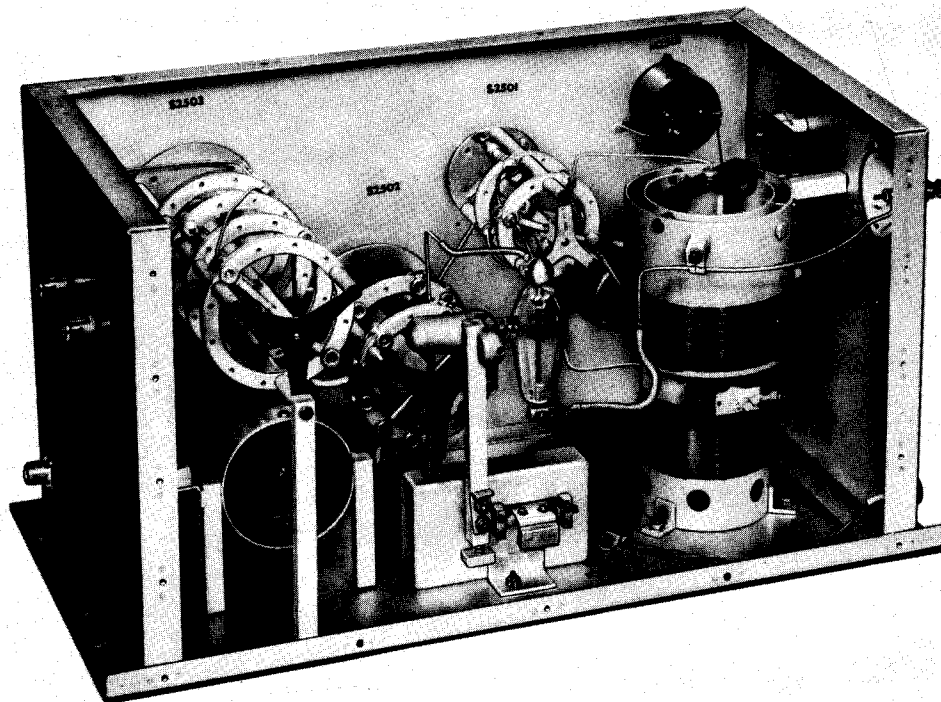
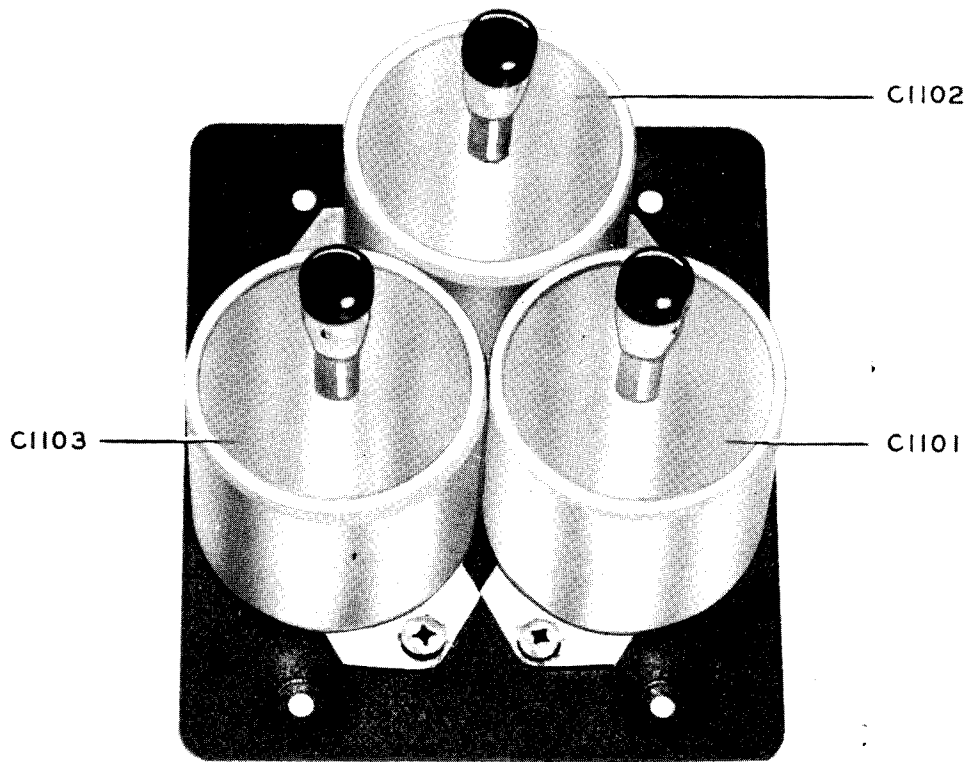

Figure 6-41B. Type CU-32/ART-13A Antenna Loading Coil—Inside

Revised 15 July 1954



**Figure 6-42. Type CU-24/ART-13 Antenna Shunt Capacitor—Top View**



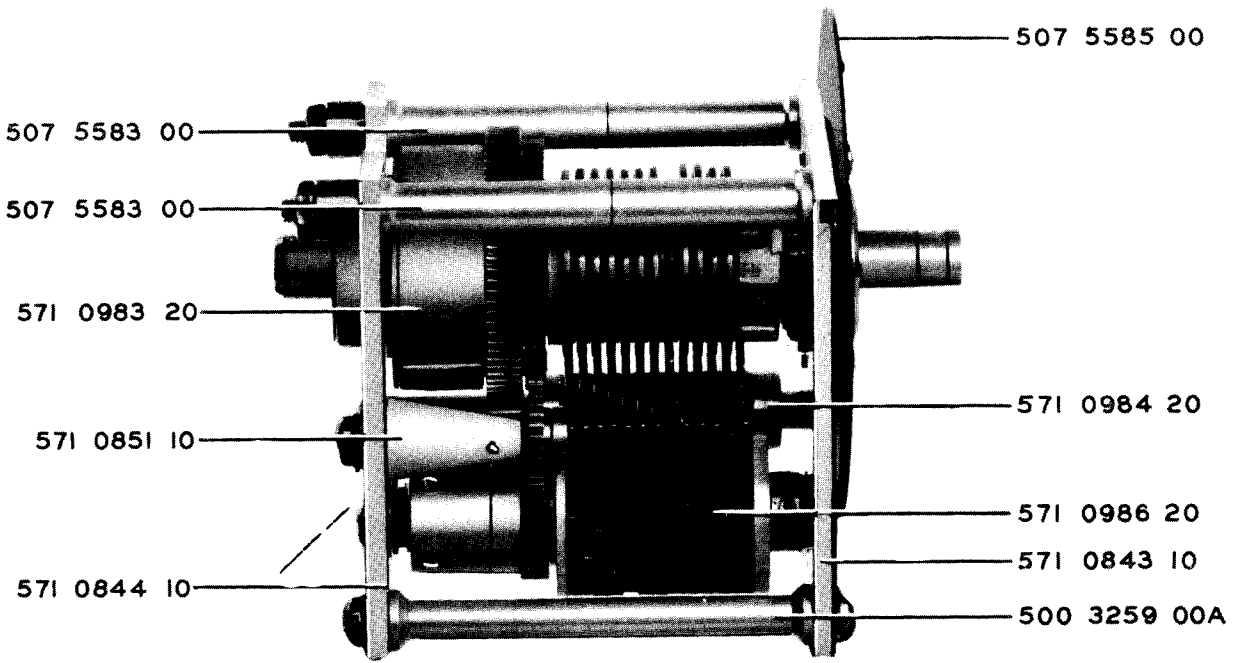

Figure 6-43. Autotune Singleturn Unit—Left Side View

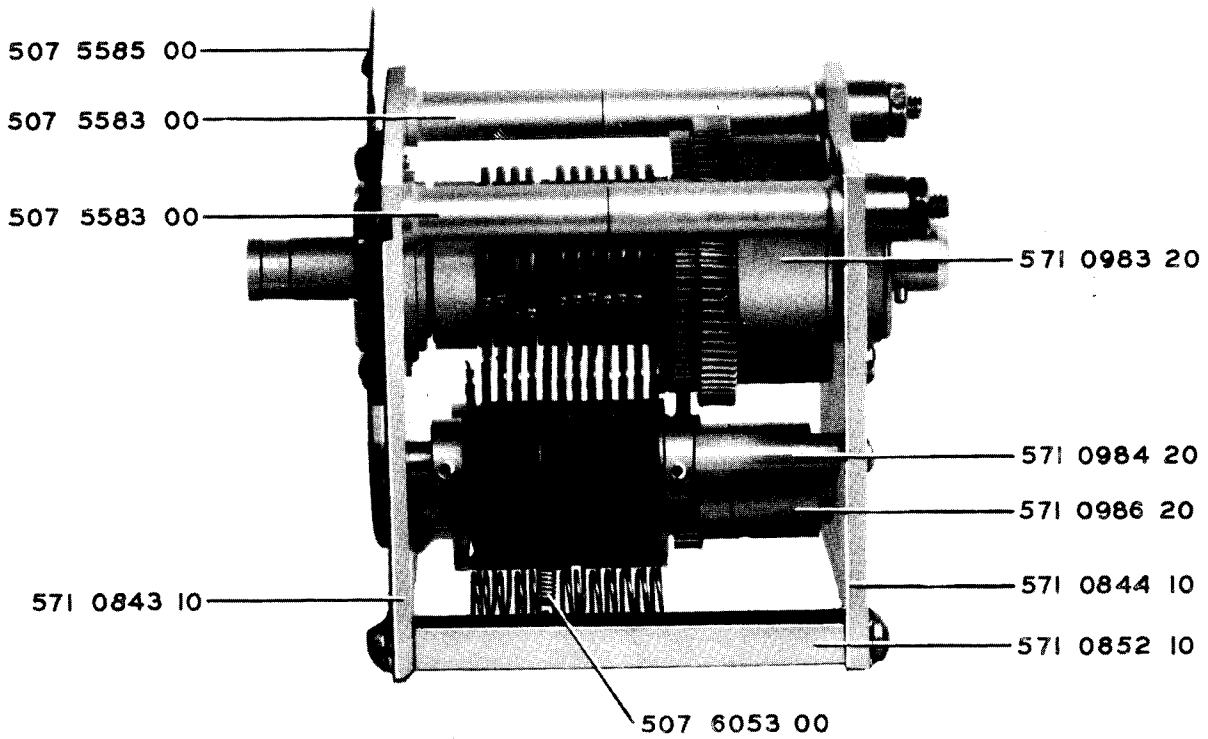

Figure 6-44. Autotune Singleturn Unit—Right Side View

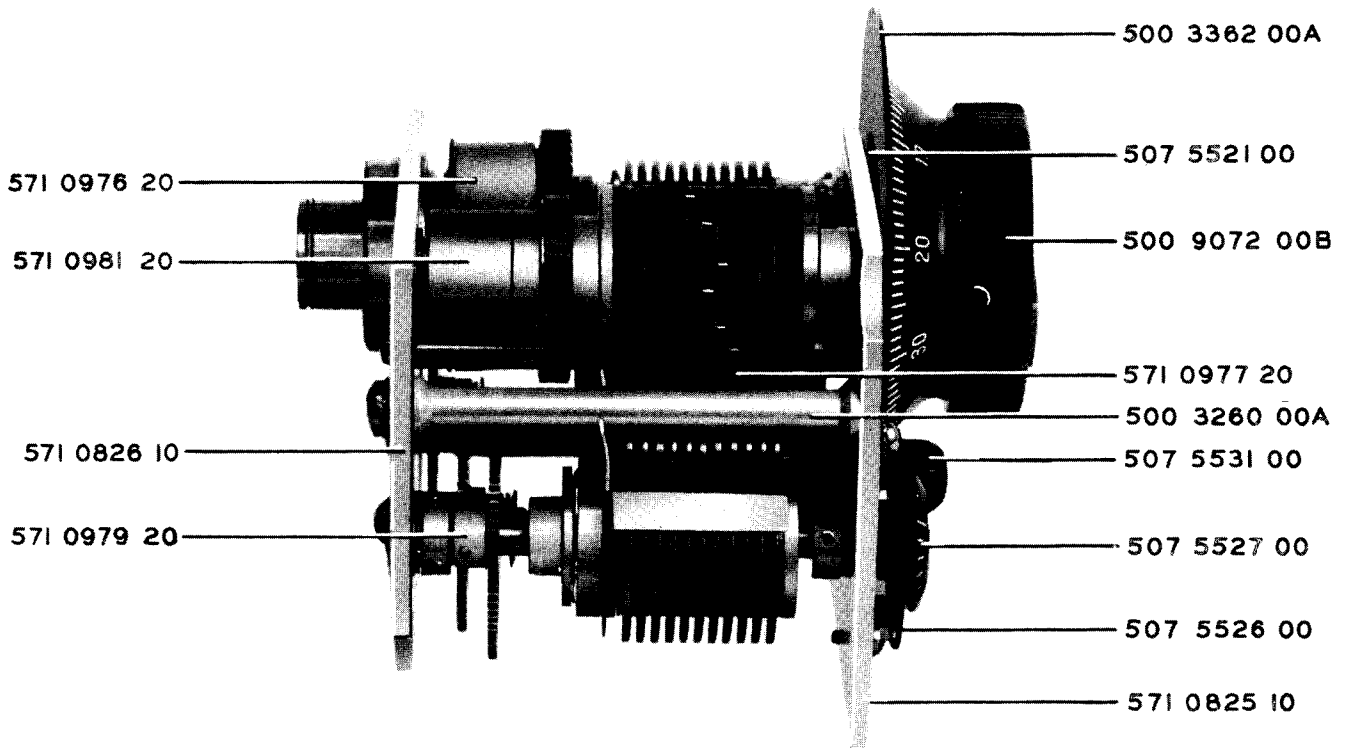

Figure 6-45. Autotune Multiturn Unit—Left Side View

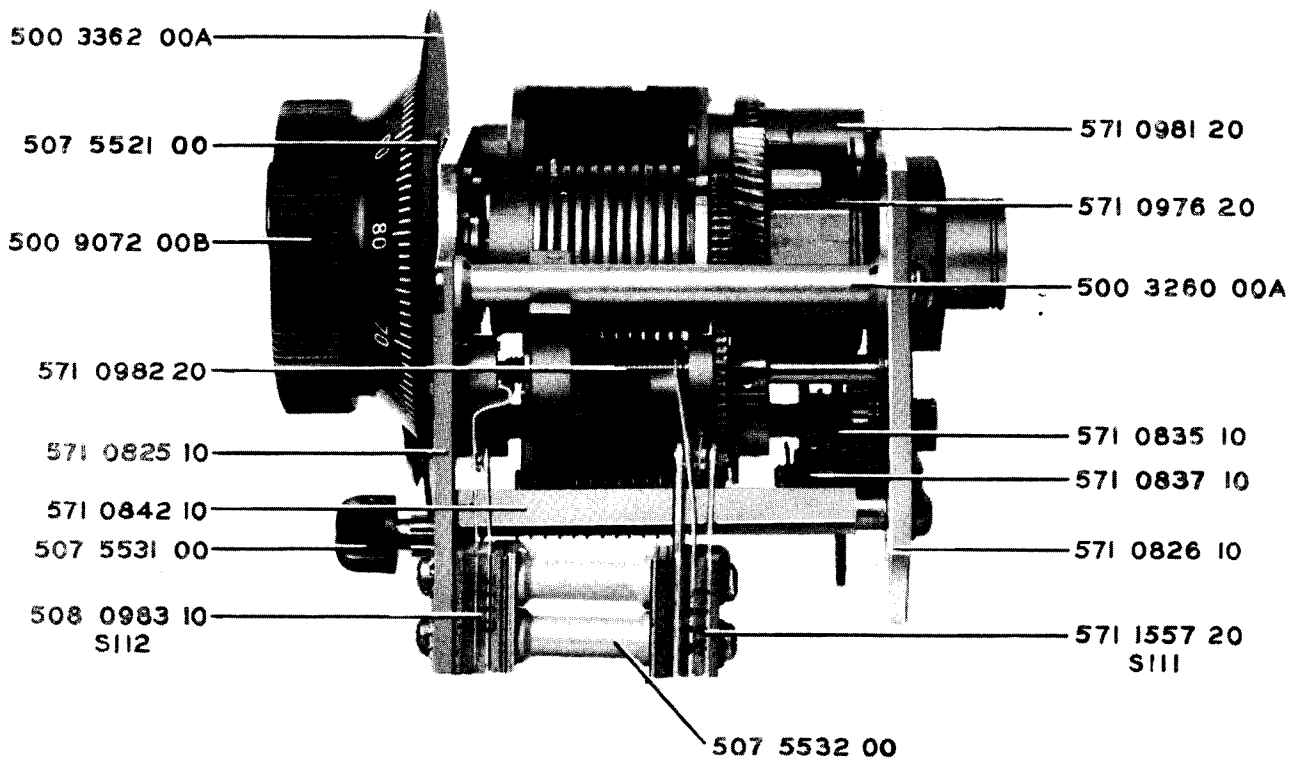

Figure 6-46. Autotune Multiturn Unit—Right Side View

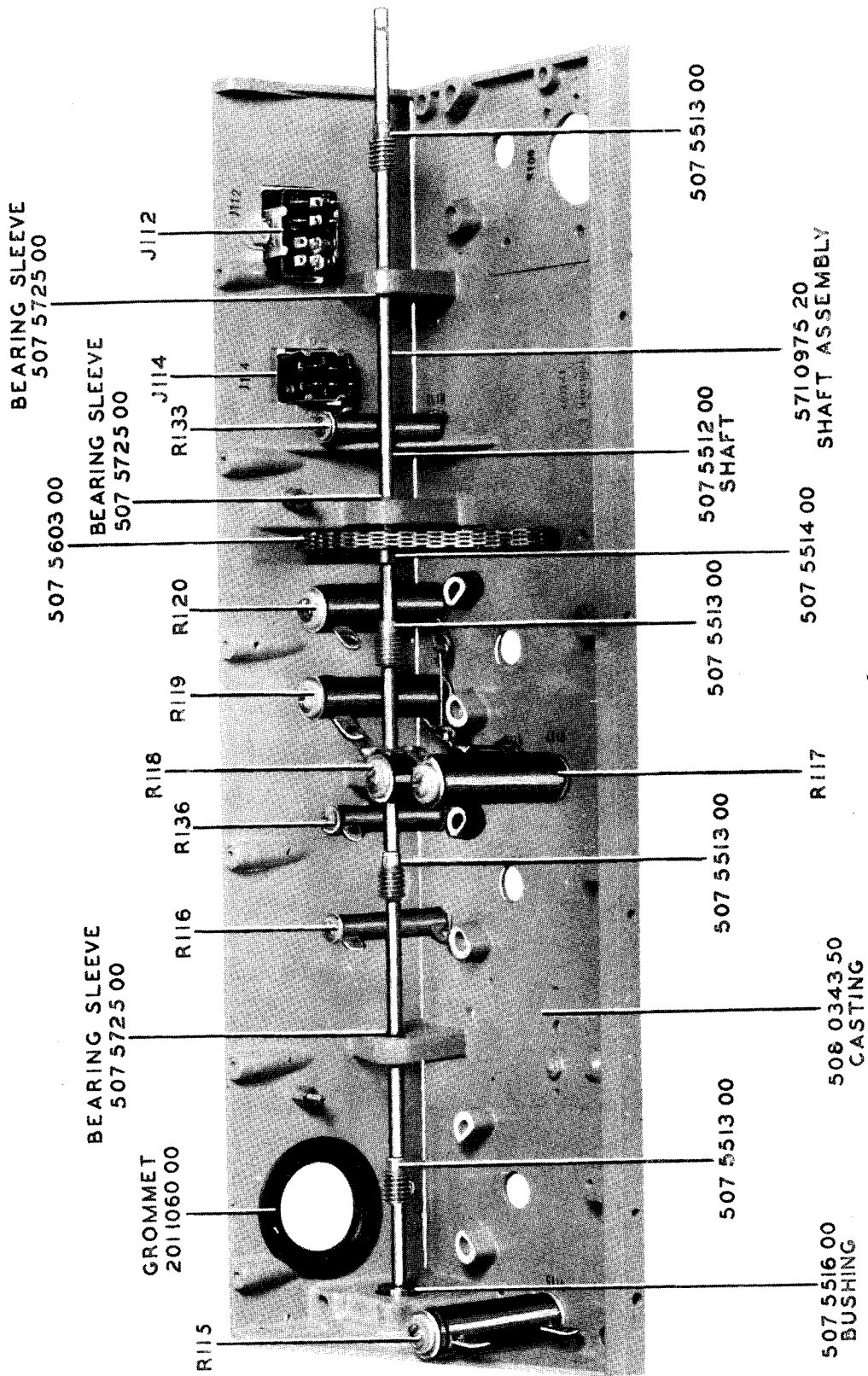

Figure 6-47. Autotune Casting—Inside View

## SECTION VII

### TABLE OF REPLACEABLE PARTS

#### 1. INTRODUCTION.

a. Component parts of the equipment are identified by means of symbol designations. Wherever it is required to reference a component, the same symbol designation is used. Thus, a part appearing on a simplified schematic, a complete circuit diagram, a wiring diagram, photograph or layout drawing, will always be identified by means of the same symbol designation. In addition, each component part is stamped with its corresponding symbol designation. These symbol designations identify the various component parts which appear in the following table.

b. Only one Symbol Designation is assigned to cover component parts with multiple electrical or mechanical characteristics. However, since at times it is desirable to identify certain electrical sections

of these component parts, suffix letters are added when necessary. Thus, C121A, C121B, and C121C identify each section of triple capacitor C121.

c. The numerical portion of the Symbol Designation has been assigned to identify the component part with a particular unit assembly. The numerical portion of symbol designations begin with 101 for the first component part in each class (i.e., component part in each alphabetical class as described above) and run consecutively for the remaining component parts in a particular class. A different numerical series of numbers is used for each unit of the equipment.

d. The following table gives a complete list of symbol designation numbers in correlation with the units.

Symbol Group	Army-Navy Type Description	Name of Unit
101- 199	T-47/ART-13	Transmitter
201- 299		**Audio
401- 499	O-16/ART-13	LFO
601- 699	C-87/ART-13 or C-740/ART-13	Pilot's Control
701- 799	CU-25/ART-13	Antenna Loading Coil
801- 899	CU-26/ART-13	Antenna Loading Coil
1101-1199	CU-24/ART-13	Antenna Shunt Capacitor
2100-2199	DY-12/ART-13	Dynamotor Power Unit (Wincharger Dynamotor)
2200-2299		**MCW-CFI
2501-2599	CU-32/ART-13A	Antenna Loading Coil
2600-2699	DY-11/ART-13	(Alternate) Dynamotor Power Unit (Russell Dynamotor)
*2600-*2699	O-17/ART-13A	LFO
2700-2799	DY- /ART-13	(Alternate) Dynamotor Power Unit (Fractional Dynamotor)
2800-2899		(Alternate) Emerson Autotune Motor
2900-2999		(Alternate) Ohio Autotune Motor

\* The reference symbols used for all parts of the Type O-17/ART-13A Low Frequency Oscillator will bear the nomenclature given above. The asterisk following such numbers will distinguish them from parts of another unit of the AN/ART-13 equipment.

\*\* Considered a part of Type T-47/ART-13 Transmitter.

TABLE OF REPLACEABLE PARTS  
 MODEL: AN/ART-13 RADIO TRANSMITTING EQUIPMENT  
 MAJOR ASSEMBLY: RADIO TRANSMITTER TYPE T-47/ART-13

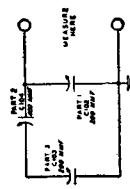
Reference Symbol	Army Stock Number Navy/Stock Number British Ref. Number	NAME OF PART and DESCRIPTION	FUNCTION	MFR. and DESIG. or AWS TYPE	CONT. or GOVT. DWG. or SPEC. No.
101-199 201-299 P402, R402 2201-2299		<b>AIRCRAFT RADIO TRANSMITTER:</b> Includes one complete set of tubes; the Type NX-128/ART-13 Dummy Low Frequency Oscillator, Audio Unit and MCW-CFI Unit		880, 17H-2	500 9358 00E
B101	(R) 16 M 4663	<b>MOTOR:</b> 1/20 hp 28 v dc nominal 20 v min 32 v max	AUTOTUNE motor	1740, NY-818C-C	508 0818 33 or 818C-C
C101		<b>CAPACITOR:</b> .000185 mf ±1% 1000 TV	HFO grid padding	700, 841-001	
C102 C103 C104	(R) 16 C 15078	<b>CAPACITOR:</b> Set of three matched ceramic capacitors packaged as a set. To be connected in equipment in accordance with the circuit at the left to provide 413 mmf ±1% 1000 TV, Temperature Coefficient minus 48 Parts per Million per °C ±5%.	Temperature compensating 	700, Type 841	571 1433 30 or GA-1433C
C105	(R) 16 C 10422	<b>CAPACITOR:</b> .005 mf ±5% 2500 TV	HFO cathode bypass	911, 4LST; 4030, HLST	925 2502 10 or 925N250K-J
C106	(R) 16 C 1044-200	<b>CAPACITOR:</b> .006 mf ±20% 1000 TV	HFO filament bypass	911, 4LS; 4030, HLS-10	910 2603 40 or 910N260C-M
C107	(R) 16 C 10240-90	<b>CAPACITOR:</b> .002 mf ±20% 1000 TV	HFO screen bypass	911, 4LS; 4030, HLS-10	910 2203 40 or 910N220C-M
C108	(R) 16 C 10019-5	<b>CAPACITOR:</b> .0005 mf ±10% 1500 TV	1st multiplier grid	4030, BE-15	915 3505 20 or 915N350E-K
C109	(R) 16 C 10241-18	<b>CAPACITOR:</b> .002 mf ±20% 1500 TV	1st multiplier cathode bypass	4030, BE-15	915 2205 40 or 915N220E-M
C110		<b>CAPACITOR:</b> See C109	1st multiplier screen supply filter		
C111	(R) 16 C 14795	<b>CAPACITOR:</b> 6 section variable ceramic	1st multiplier tuning	700, 823-003	917 6130 00 or 917N6A3

**TABLE OF REPLACEABLE PARTS**  
**MODEL: AN/ART-13 RADIO TRANSMITTING EQUIPMENT**      **MAJOR ASSEMBLY: RADIO TRANSMITTER TYPE T-47/ART-13**

Reference Symbol	Army Stock Number Navy Stock Number British Ref. Number	NAME OF PART and DESCRIPTION	FUNCTION	MFR. and DESIG. or AWS TYPE	CONT. or GOVT. DWG. or SPEC. No.
C112	(R) 16 C 9977-25	CAPACITOR: .00025 mf $\pm 10\%$ 1500 TV	2nd multiplier grid coupling	4030, BE-15	915 3255 20 or 915N325E-K
C113		CAPACITOR: See C109	2nd multiplier cathode bypass		
C114		CAPACITOR: See C109	2nd multiplier screen supply filter		
C115		CAPACITOR: See C111	2nd multiplier tuning		
C116		CAPACITOR: See C103	Power amplifier grid coupling		
C117		CAPACITOR: See C106	Power amplifier filament bypass		
C118	(R) 16 C 10250	CAPACITOR: .002 mf $\pm 20\%$ 7500 TV	Power amplifier blocking	911; 4030, A2LS	975 2201 40 or 975N220A-M
C119	(R) 16 C 10247-20	CAPACITOR: .002 mf $\pm 20\%$ 2500 TV	Power amplifier screen supply filter	911, 4LS; 4030, HLS-25	925 2203 40 or 925N220C-M
C120A	(R) 16 C 10247	CAPACITOR: .002 mf $\pm 20\%$ 5000 TV	Power amplifier supply filter	911, 4LS; 4030, HLS-50	950 2203 40 or 950N220C-M
C120B		CAPACITOR: See C120A	Power amplifier supply filter		
C121	(R) 16 C 11386-75	CAPACITOR: 3-0.1 mf $\pm 20\%$ 600 WV	C121A, C121B, C121C	911, DYRT-6111; 4210, 3XDRTW6-1	956 0001 00 or 956NT01WX1-M
C121A		CAPACITOR: Section of C121	Transient suppressing		
C121B		CAPACITOR: Section of C121	Transient suppressing		
C121C		CAPACITOR: Section of C121	Transient suppressing		
C122			C122A, C122B		

TABLE OF REPLACEABLE PARTS  
 MODEL: AN/ART-13 RADIO TRANSMITTING EQUIPMENT MAJOR ASSEMBLY: RADIO TRANSMITTER TYPE T-47/ART-13

Reference Symbol	Army Stock Number Navy Stock Number British Ref. Number	NAME OF PART and DESCRIPTION	FUNCTION	MFR. and DESIG. or AWS TYPE	CONT. or GOVT. DWG. or SPEC. No.
C122A		CAPACITOR: .00005 mf $\pm 10\%$ ceramic	Power amplifier tank padding	700, 850-002	913 4503 20 or 913N450C-K
C122B		CAPACITOR: See C122A	Power amplifier tank padding		
C124			C124A, C124B, C124C		
C124A	(R) 16 C 8301-75	CAPACITOR: .000067 mf $\pm 5\%$ ceramic	PA tank padding	700, 850-003	913 4673 10 or 913N467C-J
C124B		CAPACITOR: See C124A	PA tank padding		
C124C		CAPACITOR: See C124A	PA tank padding		
C125		CAPACITOR: Rotor assembly Stator assembly	PA tuning	830, GA-1342B 830, GA-1308A	571 1342 20 or 1342B 571 1308 10 or 1308A
C126		CAPACITOR: 2.0 mf $\pm 20\%$ 600 WV	Low voltage supply filter	911, KG-3020; 1640, A7649; 1881, 67X2	930 7824 00 or 930N78B-M
C127	(R) 16 C 10446-50	CAPACITOR: .006 mf $\pm 20\%$ 1500 TV	2nd multiplier supply filter	4030, BE-15	915 2605 40 or 915N260E-M
C128		CAPACITOR: See C118	Plate filter		
C129		CAPACITOR: See C122A	PA tank padding		
C130	(R) 16 C 7868-50	CAPACITOR: .000025 mf $\pm 10\%$ ceramic	PA tank padding	700, 850-001	913 4253 20 or 913N425C-K
C131	(R) 16 C 10063	CAPACITOR: .0008 mf $\pm 5\%$ 1000 TV	1st multiplier supply filter	4030, BE-10	910 3805 10 or 910N380E-J
C132		CAPACITOR: .004 mf $\pm 20\%$ 1200 TV	Motor B101 spark suppressor	911, BT6D4	909 0009 00

**TABLE OF REPLACEABLE PARTS**  
**MODEL: AN/ART-13 RADIO TRANSMITTING EQUIPMENT**      **MAJOR ASSEMBLY: RADIO TRANSMITTER TYPE T-47/ART-13**

Reference Symbol	Army Stock Number Navy Stock Number British Ref. Number	NAME OF PART and DESCRIPTION	FUNCTION	MFR. and DESIG. or AWS TYPE	CONT. or GOVT. DWG. or SPEC. No.
C133		CAPACITOR: See C132	Motor B101 spark suppressor		
C134	(R) 16 C 11908	CAPACITOR: Midget variable	HFO grid trimming	3410	922 5100 00 or 922N51
C135		CAPACITOR: See C134	HFO grid trimming		
C136	(R) 16 C 12192-10	CAPACITOR: 13 mmf variable ceramic	PA grid trimming	700, 822-009	917 1010 00 or 917N101
C137		CAPACITOR: .0015 mf $\pm 10\%$ 900 TV	HF noise filter	830; 4030; 911	909 2156 20 or 909N215F-K
C138	(R) 16 C 11312	CAPACITOR: 0.1 mf $\pm 10\%$ 600 WV	Low voltage filter	1640; 3030	930 0006 00
E101A	(R) 16 B 1232-50	BRUSH: + & — brush	For Autotune motor B101	1740, F-811	234 1302 00 or 234N130B
E101B		BRUSH: See E101A	For Autotune motor B101		
E102		RECEPTACLE: Mounting bracket for bayonet base lamp, type 80	For I101	1200, 80	262 1270 00 or 262N127
E103A	(R) 16 B 14906-10	RECEPTACLE: $\frac{3}{8}$ x $\frac{5}{8}$ ceramic bushing	Insulating feedthru receptacle	2410, 979A	190 2919 00 or 190NB119
E103B	(R) 16 I 509B	PLUG: $\frac{3}{8}$ x $\frac{5}{8}$ ceramic bushing	Insulating feedthru plug	2410	190 2925 00 or 190NB125
E104		STANDOFF: $\frac{3}{4}$ inch conical	Insulating standoff	2410, GS-10	190 2570 00 or 190NSN7
E105		STANDOFF: $\frac{1}{2}$ x 1 cyl	Insulating standoff	2410, 397-L1	190 2327 00 or 190NSL3



TABLE OF REPLACEABLE PARTS  
 MODEL: AN/ART-13 RADIO TRANSMITTING EQUIPMENT  
 MAJOR ASSEMBLY: RADIO TRANSMITTER TYPE T-47//ART-13

Reference Symbol	Army Stock Number Navy Stock Number British Ref. Number	NAME OF PART and DESCRIPTION	FUNCTION	MFR. and DESIG. or AWS TYPE	CONT. or GOVT. DWG. or SPEC. No.
E106A	(R) 16 B 14906-20	RECEPTACLE: $\frac{1}{2}$ x $\frac{7}{8}$ ceramic bushing	LOAD COIL terminal feedthru	2410	190 2921 00 or 190NB121
E106B	(R) 16 I 50099	PLUG: $\frac{1}{2}$ x $\frac{7}{8}$ ceramic bushing	LOAD COIL terminal feedthru	2410	190 2926 00 or 190NB126
E107		INSERT: $\frac{3}{16}$ x $\frac{5}{8}$ bushing	Insulating feedthru	2410	190 2917 00 or 190NB117
E108	(R) 16 I CR 17	BOWL: $2\frac{1}{2}$ x $3\frac{1}{8}$	Antenna feedthru	2410, GA-1741B	571 1741 20 or 1741B
E109B		PLUG: $\frac{3}{8}$ x $\frac{5}{8}$ ceramic bushing	Insulating feedthru	2410	190 2920 00 or 190NB120
I101	(R) 17 L 6682	INDICATOR: 28 v clear bulb miniature bayonet base	Transmitter power pilot lamp	1881, T3- $\frac{1}{4}$	262 3270 00 or 262N327
J101	(R) 16 J 3125	RECEPTACLE: 1 circuit jack for plugs with $\frac{1}{4}$ inch barrel	THROTTLE SWITCH cord plug receptacle	3080, SC1A; 3240	358 1040 00 or 358N104
J102	(R) 16 J 3258	RECEPTACLE: 3 circuit jack	MICROPHONE cord plug receptacle	3080, SCA2B; 3240	358 1050 00 or 358N105
J103		RECEPTACLE: See J101	KEY cord plug receptacle		
J104		RECEPTACLE: See J101	Sidetone number 1 receiver cord plug receptacle		
J105		RECEPTACLE: See J101	Sidetone number 2 receiver cord plug receptacle		
J106	(R) 17 R 1980-15	RECEPTACLE: 27 terminal wall mtg receptacle female connector	Control box cable connector plug receptacle	630, RNK-27-31SL	371 4089 00 or 371N408R
J107	(R) 17 R 1980-25	RECEPTACLE: 3 terminal wall mtg receptacle female connector	Relay supply connector plug receptacle	630, RWK-C3-31SL	371 1059 00 or 371N105R

CONTRACT or ORDER No. NXsa-44558

PAGE 5 of 52 PAGES

AN 08-30ART13-5

**TABLE OF REPLACEABLE PARTS**  
**MODEL: AN/ART-13 RADIO TRANSMITTING EQUIPMENT**      **MAJOR ASSEMBLY: RADIO TRANSMITTER TYPE T-47/ART-13**

Reference Symbol	Army Stock Number Navy Stock Number British Ref. Number	NAME OF PART and DESCRIPTION	FUNCTION	MFR. and DESIG. or AWS TYPE	CONT. or GOVT. DWG. or SPEC. No.
J108	(R) 17 R 1959-100	RECEPTACLE: 10 terminal wall mtg receptacle male connector	Dynamotor connector plug receptacle	680, FK-10-32S	371 5130 00 or 371N513
J109		RECEPTACLE: 5/8 inch push type binding post	ANTENNA connector	1320	372 2210 00 or 372N22A
J110	(R) 16 R 5319	RECEPTACLE: 5/8 inch push type binding post	RECEIVER connector	1320	372 2410 00 or 372N24A
J111	#	RECEPTACLE: 8 terminal connector socket	CFI Unit connector plug receptacle	2580, 300	366 2080 00 or 366N208
J112	#	RECEPTACLE: 12 terminal socket chassis mtg	Audio Unit connector plug receptacle	2580, 300	366 2120 00 or 366N212
J113		RECEPTACLE: 5/8 inch push type	GROUND connector	1320	372 1410 00 or 372N14A
J114		RECEPTACLE: 6 terminal socket chassis mtg	LFO connector plug receptacle	2580, 300	366 2060 00 or 366N206
J115	#	RECEPTACLE: 12 terminal octal style cable plug connector	Multiplier Unit connector plug receptacle	200, 70-12	369 1700 00 or 369N17
J116	#	RECEPTACLE: 15 terminal chassis mtg connector	K102 & S116 connector strip	2580, 300	366 2150 00 or 366N215
J117	(R) 16 P 5317	RECEPTACLE: 1/2 inch push type	LOAD COIL connector	1320	372 2110 00 or 372N21A
J118		RECEPTACLE: See J109	ANTENNA CAPACITOR connector		
K101		RELAY: 3 PDT circuit control relay	Relay, AUTOTUNE motor control Alternate Alternate	1820 257, R30F 2050, G-33177	405 0009 00 405 0012 00 405 2201 10 or 405N201A

TABLE OF REPLACEABLE PARTS  
 MODEL: AN/ART-13 RADIO TRANSMITTING EQUIPMENT  
 MAJOR ASSEMBLY: RADIO TRANSMITTER TYPE T-47/ART-13

Reference Symbol	Army Stock Number Navy Stock Number British Ref. Number	NAME OF PART and DESCRIPTION	FUNCTION	MFR. and DESIG. or AWS TYPE	CONT. or GOVT. DWG. or SPEC. No.
K102		RELAY: DT multi-contact	Relay, keying Alternate	2050 4310	410 0008 00 410 0011 00
K103	(R) 16 R 5069-10	RELAY: 2 PDT 1 PST circuit control relay	Relay, CW emission	2050, G-32811	410 1700 00 or 410N17
K104	(R) 16 R 5069-5	RELAY: 2 PDT circuit Control relay	Relay, VOICE emis- sion Alternate Alternate	257, R-22B 2050 2050, G-32734	410 0013 00 410 0014 00 410 1600 00 or 410N16
K105		RELAY: 1 PDT, 1 pole normally open & 1 pole normally closed with mycalex insulation 18-32 v dc	Relay, output circuit selecting	2050, G-36427	410 0010 00
L101	(R) 16 C 27595	INDUCTOR: Special precision wound inductor	HFO tuning inductor	830, GA-671D	571 0671 40 or 671D
L102		CHOKE: Multi-section. 2.5 uh. 0.125 amp 50 ohm	HFO cathode RF choke	3220, R100-U 3090	240 5300 00 or 240N53
L103		CHOKE: See L102	HFO screen RF choke	4335	240 6000 00 or 240N60
L104	(R) 16 C 17184-20	CHOKE: 2 section 208 mh $\pm 1\%$ 2 ohms duo-lateral wound	HFO feed choke	830, GA-1687B	571 1687 20 or 1687B
L105	(R) 16 C 27595-55	INDUCTOR: Special precision wound inductor	1st multiplier tuning inductor	830, GA-1686B	571 1686 20 or 1686B
L106	(R) 16 C 27595-50	INDUCTOR: Special precision wound inductor	2nd multiplier tuning inductor	3220, R100	240 2100 00 or 240N2A
L107	(R) 16 C 17500	CHOKE: Multi-section duo-lateral wound 2.5 mh 0.125 amp 35 to 50 ohm	PA grid feed choke	830, GA-1404C	571 1404 30 or 1404C
L108	(R) 16 C 27595-40	CHOKE: 175 turns, close wound, single layer	PA feed choke	950	240 5900 00 or 240N59
L109	(R) 16 C CR-240N59	CHOKE: Multi-section 6 mh 21 ohms	PA feed choke		

CONTRACT or ORDER No. NXsa-44558

PAGE 7 of 52 PAGES

**TABLE OF REPLACEABLE PARTS**  
**MODEL: AN/ART-13 RADIO TRANSMITTING EQUIPMENT**      **MAJOR ASSEMBLY: RADIO TRANSMITTER TYPE T-47/ART-13**

Reference Symbol	Army Stock Number Navy Stock Number British Ref. Number	NAME OF PART and DESCRIPTION	FUNCTION	MFR. and DESIG. or AWS TYPE	CONT. or GOVT. DWG. or SPEC. No.
L110	(R) 16 C 17181	CHOKE: Close wound, single layer type	Output network static drain choke	880, GA-1395C	571 1395 30 or 1395C
L112	(R) 16-V-1200	INDUCTOR: Variometer	PA tank inductor	880, GA-479D	571 0479 40 or 479D
L113	(R) 16 C 21393	INDUCTOR: 43 turns, space wound, number 14 tinned	Antenna loading inductor	880, GA-1258C	571 1258 30 or 1258C
L114	(R) 16 C 27595-20	INDUCTOR: 16 turns, space wound, number 16 tinned	PA tank padding inductor	880, GA-1114A	571 1114 10 or 1114A
L115		CHOKE: See L102	1st multiplier feed choke		
L116	(R) 16 C 17184-15	CHOKE: Multi-section duo-lateral wound 1.0 mh, 0.3 amp 10 ohms	HF noise filter choke	3220, R-300U; 3090	240 5800 00 or 240N58
L117		CHOKE: See L116	Multiplier filter choke		
M101		METER: 0-0.25 amp RF meter	Antenna current ammeter	1881, DW44; 4900, NT-33	451 0001 00 or 451ND0.25SN
M102	(R) 16 M 3322	METER: 0-1 ma dc meter 2% accuracy	Voltage-current indicating meter	1881, DW41; 4900, NX-33	450 4125 00 or 450ND1SN
P101	#	PLUG: 12 term octal style female connector chassis	Multiplier unit connector plug mtg	200, MIP	369 1600 00 or 369N16
P102	#	PLUG: Part of K102	K102 & S116 connector plug		
R101	(R) 16 R 17310-177	RESISTOR: 22,000 ohm $\pm 10\%$ 1 w	HFO grid	2360, BT1-Navy	729 7224 20 or 729NG22M-K
R102	(R) 16 R 17347-15	RESISTOR: 100,000 ohm $\pm 10\%$ 1 w	1st multiplier grid	2360, BT1-Navy	729 7100 42 or 729NG100M-K
R103	(R) 16 R 172558-58-2	RESISTOR: 47 ohm $\pm 20\%$ 1 w	1st multiplier grid parasitic suppressor	4230	729 7474 00 or 729NG47-M

MODEL: AN/ART-13 RADIO TRANSMITTING EQUIPMENT  
 TABLE OF REPLACEABLE PARTS  
 MAJOR ASSEMBLY: RADIO TRANSMITTER TYPE T-47/ART-13

Reference Symbol	Army Stock Number Navy Stock Number British Ref. Number	NAME OF PART and DESCRIPTION	FUNCTION	MFR. and DESIG. or AWS TYPE	CONT. or GOVT. DWG. or SPEC. No.
R104		RESISTOR: See R103	1st multiplier screen parasitic suppressor	3450, 0218	710 0078 00 or 710NC20MA-K
R105		RESISTOR: 20,000 ohm $\pm 10\%$ 25 w	1st multiplier screen		
R106		RESISTOR: See R103	2nd multiplier grid parasitic suppressor		
R107		RESISTOR: See R102	2nd multiplier grid		
R108		RESISTOR: See R103	2nd multiplier screen parasitic suppressor		
R109		RESISTOR: See R105	2nd multiplier screen		
R110		RESISTOR: See R105	PA grid		
R111	(R) 16 R 21006-180	RESISTOR: 235 ohm $\pm 2\%$ 1 w	PA grid metering	2360, WW3	721 3235 70 or 721NL235-G
R112		RESISTOR: See R103	PA screen parasitic suppresser		
R113	(R) 16 R 21006-90	RESISTOR: 150 ohm $\pm 20\%$ 10 w	Transient suppressor	3450, BD	710 0019 00 or 710NA150B-M
R114		RESISTOR: See R113	Transient suppressor		
R115	(R) 16 R 21006-35	RESISTOR: 100 ohm $\pm 10\%$ 25 w	Motor torque retainer resistor	3450	710 0048 00 or 710NC100A-K
R116	(R) 16 R 21000-250	RESISTOR: 1 ohm $\pm 10\%$ 10 w	Filament voltage dropping	3450, BD	710 1112 00 or 710NA1A-K
R117	(R) 16 R 21018-15	RESISTOR: 5000 ohm $\pm 10\%$ 25 w	LV supply bleeder	3450, 0212	710 3541 40 or 710NC5MA-K
R118		RESISTOR: See R117	LV supply bleeder		

CONTRACT or ORDER No. NXsa-44558

PAGE 9 of 52 PAGES

## TABLE OF REPLACEABLE PARTS

## MAJOR ASSEMBLY: RADIO TRANSMITTER TYPE T-47/ART-13

## MODEL: AN/ART-13 RADIO TRANSMITTING EQUIPMENT

Reference Symbol	Army Stock Number Navy Stock Number British Ref. Number	NAME OF PART and DESCRIPTION	FUNCTION	MFR. and DESIG. or AWS TYPE	CONT. or GOVT. DWG. or SPEC. No.
R119		RESISTOR: See R117	LV supply bleeder		
R120		RESISTOR: See R117	LV supply bleeder		
R121	(R) 16 R 21000-110	RESISTOR: 0.8 ohm $\pm 10\%$ 50 w	Filament voltage dropping	3450	710 0013 00 or 710ND0.8A-K
R123	(R) 16 R 21004-20	RESISTOR: 12.6 ohm $\pm 10\%$ 25 w	Filament dropping	3450	710 0045 00 or 710NC12.6A-K
R124	(R) 16 R 21019-90	RESISTOR: 25,000 ohm $\pm 10\%$ 25 w	TUNE-PA screen voltage dropping	3450, 0219	710 0081 00 or 710NC25MA-K
R128	(R) 16 R 21015-100	RESISTOR: 4000 ohm $\pm 2\%$ 1 w	M102 meter multiplier	2360, WW3	721 3447 00 or 721NL4M-G
R129	(R) 16 R 21007-150	RESISTOR: 1000 ohm $\pm 10\%$ 10 w	2nd multiplier cathode	3450, BD	710 1141 20 or 710NA1MA-K
R130		RESISTOR: See R129	1st multiplier cathode		
R131	(R) 16 R 21006-325	RESISTOR: 350 ohm $\pm 10\%$ 10 w	HFO cathode	3450, BD	710 0021 00 or 710NA350A-K
R132	(R) 16 R 21011-25	RESISTOR: 50,000 ohm $\pm 2\%$ 1 w	M102 meter multiplier	2360, WW3	721 3504 70 or 721NL50M-G
R133	(R) 16 R 21005-75	RESISTOR: 50 ohm $\pm 10\%$ 10 w	Filament voltage dropping	3450, BD	710 1501 20 or 710NA60A-K
R134	(R) 16 R 17260-40-3	RESISTOR: 75 ohm $\pm 10\%$ 1/2 w	Audio amplifier input terminating	2360, BW1/2	707 7552 00 or 707N75N-K
R135	(R) 16 R 17256-60	RESISTOR: 10 ohm $\pm 10\%$ 1/2 w	MCW oscillator cathode	2360, BW1/2	707 1052 00 or 707N10N-K
R136	(R) 16 R 17256-60	RESISTOR: See R113	I101 voltage dropping	2360, BW1/2	707 1052 00 or 707N10N-K
R137	#	RESISTOR: 22,000 ohm $\pm 20\%$ 1 w	Oscillation suppressor	2360, BT1-Navy	729 7224 40

TABLE OF REPLACEABLE PARTS  
 MODEL: AN/ART-13 RADIO TRANSMITTING EQUIPMENT  
 MAJOR ASSEMBLY: RADIO TRANSMITTER TYPE T-47/ART-13

Reference Symbol	Army Stock Number Navy Stock Number British Ref. Number	NAME OF PART and DESCRIPTION	FUNCTION	MFR. and DESIG. or AWS TYPE	CONT. or GOVT. DWG. or SPEC. No.
S101		SWITCH: Moving switch arm	HFO grid tank padding	830, GA-1445A;	571 1445 10 or 1445A
S102		Stationary switch arm	cap connector	830, GA-2002A	571 2002 10 or 2002A
S103		SWITCH: 18 contact single pie	1st multiplier tank cap selector	830	500 0085 00
S104	(R) 17 S 28256-80	SWITCH: 7 contact single pie	2nd multiplier tank cap selector	830	500 0206 00
S105		SWITCH: Single pole normally open 20 amp 24 v dc	TEST	1010, 8817	260 1100 00 or 260N110
S106		SWITCH: 2 circuit 3 position non-shorting	Metered circuit selector	3410	259 1391 00 or 259N139A
S107		SWITCH: 5 circuit 3 position shorting	Power level selector	3410	259 0004 00
S108		SWITCH: 4 circuit 2 position shorting	LOCAL-REMOTE	3410	259 1411 00 or 259N141A
S109		SWITCH: 1 circuit 12 position non-shorting	Autotune CHANNEL selecting	3410	259 1401 00 or 259N140A
S110		SWITCH: 1 circuit 12 position shorting	Autotune circuit seeking	3410, 25851-DH-1	259 1371 00 or 259N137A
S111		SWITCH: 3 circuit 4 position shorting	EMISSION selector	3410	259 1361 20 or 259N136B
S112		SWITCH: Single pole 1 normally closed 1 normally open contact leaf	Rear limit section	830, GA-1557B	571 1557 20 or 1557B
S113		SWITCH: Single pole normally closed contact leaf	Forward limit section	830, Y-983A	508 0983 10 or 983A
S114		SWITCH: Multiplier section switch assembly	S113A, S113B, S113C, S113D, S113E, S113F, S113G, S113H	830, 186P-1	571 0885 30 or 885C

AN 08-30ART13-5

TABLE OF REPLACEABLE PARTS  
 MODEL: AN/ART-13 RADIO TRANSMITTING EQUIPMENT  
 MAJOR ASSEMBLY: RADIO TRANSMITTER TYPE T-47/ART-13

Reference Symbol	Army Stock Number Navy Stock Number British Ref. Number	NAME OF PART and DESCRIPTION	FUNCTION	MFR. and DESIG. or AWS TYPE	CONT. or GOVT. DWG. or SPEC. No.
S113A		SWITCH: Single contact switch arm assembly	PA tank padding cap connector	830, GA-1105A	571 1105 10 or 1105A
S113B		SWITCH: Double contact switch arm assembly	PA tuning cap connector	830, GA-1083A	571 1083 10 or 1083A
S113C		SWITCH: Single contact switch arm assembly	PA tank inductor tap selecting	830, GA-1109A	571 1074 10 or 1074A
S113D		SWITCH: Single pole, 1 normally open contact leaf	Keying interlock	830, Y-1048A	508 1048 10 or 1048A
S113E		SWITCH: Single contact switch arm assembly	Padding inductor connector	830, GA-1082A	571 1082 10 or 1082A
S113F		SWITCH: Single contact arm assembly	Padding cap connector	830, GA-1079A	571 1079 10 or 1079A
S113G		SWITCH: See S113F	Padding cap connector		
S113H		SWITCH: See S113F	Padding cap connector		
S114		SWITCH: 1 SPST 1 normally open 1 normally closed contact leaf	Oscillator circuit selecting	830, Y-1196B	508 1136 20 or 1136B
S115		SWITCH: Single pole normally open contact leaf	2nd multiplier cathode grounding	830, Y-981A	508 0981 10 or 981A
S116	(CG24163)	SWITCH: 8 amp 250 v AC SPDT vacuum contact	Antenna changeover	1881, GL-1S21; 4240, GL34	260 6010 00 or 260N601
T101		TRANSFORMER: Primary 15,000 ohm CT, 150 ma Secondary number 1: 7300 ohm 4000 TV Secondary number 2: 970 ohm 2500 TV 300-4000 cps $\pm 2$ db	Modulation	780, 7950	677 0002 00
T102	(R) 16 T CR GA 1716B	TRANSFORMER: Variable RF coupling	Antenna ammeter coupling	830, GA-1716B	571 1716 20 or 1716B



TABLE OF REPLACEABLE PARTS  
 MODEL: AN/ART-13 RADIO TRANSMITTING EQUIPMENT  
 MAJOR ASSEMBLY: RADIO TRANSMITTER TYPE T-47/ART-13

Reference Symbol	Army Stock Number Navy Stock Number British Ref. Number	NAME OF PART and DESCRIPTION	FUNCTION	MFR. and DESIG. or AWS TYPE	CONT. or GOVT. DWG. or SPEC. No.
V101	16 T 12337	TUBE: Type 837, beam pentode	HFO	* * 837	254 0406 00
V102	16 T 12905	TUBE: Type 1625 beam pentode	1st freq multiplier	* * 1625	254 0458 00
V103		TUBE: See V102	2nd freq multiplier		
V104	16 T 12261	TUBE: Type 813, beam pentode	Power amplifier	* * 813	254 0397 00
V105	16 T 12242	TUBE: Transmitting tube, type 811	Modulator	* * 811	254 0395 00
V106		TUBE: See V105	Modulator		
X101	(R) 16S 6182-83	SOCKET: 7 terminal base Isolantite	For V101	2570, 227	220 5730 00 or 220N573
X102		SOCKET: See X101	Alternate	2570, 227	220 1006 00
X103		SOCKET: See X101	For V102		
X104	(R) 16 S 6184	SOCKET: 7 terminal "Jumbo" wafer	For V103		
X105	(R) 16 S 4950	SOCKET: 4 prong low loss ceramic	For V104	2570, 237	220 5711 00 or 220N571A
X106		SOCKET: See X105	Alternate	2570, 237	220 5710 00
			For V105	2570, 224	220 5450 00 or 220N545
			For V106		

AN 08-30ART13-5

## TABLE OF REPLACEABLE PARTS

RADIO TRANSMITTER TYPE T-47/ART-13  
MAJOR ASSEMBLY: AUDIO AMPLIFIER

## MODEL: AN/ART-13 RADIO TRANSMITTING EQUIPMENT

Reference Symbol	Army Stock Number Navy Stock Number British Ref. Number	NAME OF PART and DESCRIPTION	FUNCTION	MFR. and DESIG. or AWS TYPE	CONT. or GOVT. DWG. or SPEC. No.
C201	(R) 16 C 9677	CAPACITOR: 20 mf $\pm 100\%$ —10% 100 WV	Microphone supply filter	911, RVL-10051-1 3030, SPO-38482	188 3310 00 or 188N38A
C202		CAPACITOR: See C201	Audio amplifier cathode bypass	1640; 3030	930 0010 00
C203		CAPACITOR: .05 mf $\pm 20\%$ —10% 600 WV	Audio amplifier screen bypass	4030, BE-15	915 2605 20 or 915N260E-K
C204	(R) 16 C 10446	CAPACITOR: .006 mf $\pm 10\%$ 1500 TV	Audio driver grid coupling	4030, BE-15	915 2105 20 or 915N210E-K
C205	(R) 16 C 10087-50	CAPACITOR: .001 mf $\pm 10\%$ 1500 TV	Audio amplifier de-coupling	4030, BE-15	915 2305 20 or 915N230E-K
C206	(R) 16 C 10827-7	CAPACITOR: .003 mf $\pm 10\%$ 1500 TV	Audio driver output coupling	4030, BE-15	915 2305 20 or 915N230E-K
C207		CAPACITOR: See C201	Audio driver cathode bypass		
C208		CAPACITOR: See C201	Sidetone amplifier cathode coupling		
C209	(R) 16 C 11701-25	CAPACITOR: .01 mf $\pm 60\%$ —20% 400 WV	Modulator grid R.F. bypass Alternate	ASA: CN35A103 911, 1WL	934 0003 00 909 0002 00
C210		CAPACITOR: See C209	Modulator grid R.F. bypass		
P201		PLUG: 12 terminal connector chassis mtg	Audio amplifier unit connector	2580, P-312-AB	365 2120 00 or 365N212
R201		RESISTOR: 220 ohm $\pm 5\%$ 1 w	Microphone current limiting	90	703 1220 10 or 703NA220-J
R202		RESISTOR: 100 ohm $\pm 5\%$ 1 w	Microphone current limiting	90	703 1100 10 or 703NA100-J

**TABLE OF REPLACEABLE PARTS**  
**MODEL: AN/ART-13 RADIO TRANSMITTING EQUIPMENT**  
**MAJOR ASSEMBLY: AUDIO AMPLIFIER**  
**RADIO TRANSMITTER TYPE T-47/ART-13**

Reference Symbol	Army Stock Number Navy Stock Number British Ref. Number	NAME OF PART and DESCRIPTION	FUNCTION	MFR. and DESIG. or AWS TYPE	CONT. or GOV'T. DWG. or SPEC. No.
R203	(R) 16 R 17310-59	RESISTOR: 15,000 ohm $\pm 5\%$ $\frac{1}{2}$ w	Microphone output coupling	2360, BT $\frac{1}{2}$ -Navy	729 5154 10 or 729NE15M-J
R204		RESISTOR: See R201	T201 pri terminating		
R205	(R) 16 R 17354-14-200	RESISTOR: 470,000 ohm $\pm 10\%$ $\frac{1}{2}$ w	Audio amplifier grid	2360, BT $\frac{1}{2}$ -Navy	729 5470 42 or 729NE470M-K
R206	(R) 16 R 21005-25	RESISTOR: 42 ohm $\pm 10\%$ 10 w	Audio amplifier filament current dividing	3450, BD	710 1422 20 or 710NA42B-K
R207	(R) 16 R 17274-28	RESISTOR: 2200 ohm $\pm 10\%$ 1 w	Audio amplifier cathode	2360, BW1-Navy	708 0002 00 or 708N2200NA-K
R208	(R) 16 R 17375	RESISTOR: 1 meg $\pm 10\%$ $\frac{1}{2}$ w	Audio amplifier screen decoupling	2360, BT $\frac{1}{2}$ -Navy	729 0008 00 or 729NE1Meg-K
R209	(R) 16 R 17352-2	RESISTOR: 220,000 ohm $\pm 10\%$ $\frac{1}{2}$ w	Audio amplifier decoupling	2360, BT $\frac{1}{2}$ -Navy	729 5220 42 or 729NE220M-K
R210		RESISTOR: See R205	Audio driver grid		
R211		RESISTOR: 100,000 ohm $\pm 5\%$ $\frac{1}{2}$ w	Sidetone amplifier grid	2360, BT $\frac{1}{2}$ -Navy	729 5100 41 or 729NE100M-J
R212	(R) 16 R 17354-14-150	RESISTOR: 470,000 ohm $\pm 5\%$ $\frac{1}{2}$ w	Sidetone amplifier grid coupling	2360, BT $\frac{1}{2}$ -Navy	729 5470 41 or 729NE470M-J
R213	(R) 16 R 17367-150	RESISTOR: 750,000 ohm $\pm 5\%$ $\frac{1}{2}$ w	Audio driver decoupling	2360, BT $\frac{1}{2}$ -Navy	729 5750 41 or 729NE750M-J
R214		RESISTOR: 250 ohm $\pm 10\%$ 1 w	Audio driver cathode	2360, BW1-Navy	708 2505 12 or 708N250NA-K
R215		RESISTOR: See R214	Sidetone amplifier cathode		

CONTRACT or ORDER No. NXsa-44558

PAGE 15 of 52 PAGES

**TABLE OF REPLACEABLE PARTS**  
**MODEL: AN/ART-13 RADIO TRANSMITTING EQUIPMENT**  
**MAJOR ASSEMBLY: AUDIO AMPLIFIER**  
**RADIO TRANSMITTER TYPE T-47/ART-13**

Reference Symbol	Army Stock Number Navy Stock Number British Ref. Number	NAME OF PART and DESCRIPTION	FUNCTION	MFR. and DESIG. or AWS TYPE	CONT. or GOVT. DWG. or SPEC. No.
R216		RESISTOR: 220 ohm $\pm 10\%$ $\frac{1}{2}$ w	T201 primary terminal	2360, BW $\frac{1}{2}$	707 2205 20 or 707N220N-K
S201		SWITCH: DPDT toggle 1 amp 250 v dc or 3 amp 125 v dc	Microphone circuit selector switch	2160, 24003	266 0004 00
S202		SWITCH: 1 pole 6 position 1 section shorting	Sidetone amplifier output control switch	3030	259 1490 00 or 259N149
T201	(R) 16 T 6282-20	TRANSFORMER: Primary: 75 ohm secondary: 125,000 ohm 100-5000 cps 1000 TV	Audio amplifier input coupling	780, 7823	677 2590 00 or 677N259
T202	(R) 16 P CR 677N253	TRANSFORMER: Primary: 5000 ohm 30 ma secondary: 2000 ohm 1500 TV	Audio driver output coupling	780, 7821	677 2530 00 or 677N253
T203	(R) 16 T CR 677N254	TRANSFORMER: Primary: 4000 ohm 30 ma secondary: tapped 200 ohm 50 ohm 12.5 ohm 8.12 ohm 0.78 ohm 0.195 ohm 1500 TV	Sidetone amplifier output coupling	780, 10082	677 2540 00 or 677N254
V201	16 T 13600	TUBE: Triple-grid amplifier	Audio amplifier	* * 12SJ7	254 0254 00
V202	16 T 11451	TUBE: Beam pentode	Audio driver	* * 6V6GT	254 0200 00
V203		TUBE: See V202	Sidetone amplifier		
X201	(R) 16 S 4671-5	SOCKET: 8 terminal Octal tube	For V201	200, 88-8	220 1850 00 or 220N185
X202		SOCKET: See X201	For V202		
X203		SOCKET: See X201	For V203		

TABLE OF REPLACEABLE PARTS  
 MODEL: AN/ART-13 RADIO TRANSMITTING EQUIPMENT  
 MAJOR ASSEMBLY: LF OSCILLATOR TYPE 0-16/ART-13

Reference Symbol	Army Stock Number Navy Stock Number British Ref. Number	NAME OF PART and DESCRIPTION	FUNCTION	MFR. and DESIG. or AWS TYPE	CONT. or GOVT. DWG. or SPEC. No.
401-499		LOW FREQUENCY OSCILLATOR: Includes tube. Frequency range 200 kc to 1500 kc. Interchangeable with dummy LFO Oscillator Type NX-128/ART-13		880, 33W-1	520 0219 00
C401	# (R) 16 C 10241-18	CAPACITOR: .002 mf $\pm 20\%$ 1500 TV	LFO screen bypass	4080, BE-15	915 2205 40 or 915N220E-M
C402	# (R) 16 C 9848-53-42	CAPACITOR: .00005 mf $\pm 20\%$ 900 TV	LFO cathode coupling	4080, Type "C"; 911, 1 WL	909 4508 40 or 909N450C-M
C403	# (R) 16 C 8364	CAPACITOR: .0003 mf $\pm 2\%$ 1000 TV	LFO feedback coupling	700, 816-085	913 8807 00 or 913N880-G
C404	# (R) 16 C 8377	CAPACITOR: Set of three matched ceramic capacitors packaged as a set. To be connected in parallel to provide 0.00083 mf $\pm 1/2\%$ temp coef neg, 150 parts per million per degree C $+15 -87$ ppm/ $^{\circ}$ C 500 WV	LFO feedback coupling	700, 816-044	913 1100 00 or 913NA1
C405A	# (R) 16 C 10240-30	CAPACITOR: .002 mf $\pm 1\%$ 500 TV	LFO cathode bypass	4170	912 2208 60 or 912N220H-F
C405B	#	CAPACITOR: See C405A	LFO cathode bypass		
C405C	# (R) 16 C 10078	CAPACITOR: .01 mf $\pm 1\%$ 500 TV	LFO cathode bypass	4170	912 2108 60 or 912N210H-F
C406	# (R) 16 C	CAPACITOR: .000125 mf $\pm 2\%$ 1000 TV	LFO cathode coupling	700, 814-106	913 0001 00
C407	# (R) 16 C 8379	CAPACITOR: Set of three matched ceramic capacitors packaged as a set. To be connected in parallel to provide 0.00088 mf $\pm 10\%$ temp coef neg, 32 parts per million per degrees C $+15 -61$ ppm/ $^{\circ}$ C 500 WV	LFO grid padding	700, 816-043	913 1200 00 or 913NA2
C408A	# (R) 16 C 10207-118	CAPACITOR: .0015 mf $\pm 1\%$ 1000 TV	LFO grid padding	4170	912 2158 60 or 912N215H-F

CONTRACT or ORDER No. NX5a-44558

PAGE 17 of 52 PAGES

AN 08-30ART13-5

TABLE OF REPLACEABLE PARTS  
 MAJOR ASSEMBLY: LF OSCILLATOR TYPE 0-16/ART-13

Reference Symbol	Army Stock Number Navy Stock Number British Ref. Number	NAME OF PART and DESCRIPTION	FUNCTION	MFR. and DESIG. or AWS TYPE	CONT. or GOVT. DWG. or SPEC. No.
C408B	# (R) 16 C 8849	CAPACITOR: .00015 mf $\pm 2\%$ 1000 TV	LFO grid padding	700, 810-250	913 0017 00 or 913N315N6.6-G
C408C	#	CAPACITOR: See C408	LFO grid padding		
C409A	# (R) 16 C 10005-20	CAPACITOR: See C405A	LFO grid padding		
C409B	#	CAPACITOR: .0004 mf $\pm 1\%$ 500 TV	LFO grid padding	4170	912 3408 60 or 912N34H-F
C409C	# (R) 16 C 8866-30	CAPACITOR: .00085 mf $\pm 2\%$ 1000 TV	LFO grid padding	700, 816-041	913 0014 00 or 913N335N3.3-G
C410A	# (R) 16 C 8859	CAPACITOR: .00025 mf $\pm 2\%$ 1000 TV	LFO grid padding	700, 810-290	913 0024 00 or 913N325N7-G
C410B	#	CAPACITOR: See C405A	LFO grid padding		
C410C	#	CAPACITOR: See C405A	LFO grid padding		
C410D	#	CAPACITOR: See C408A	LFO grid padding		
C411	# 16 C 12196	CAPACITOR: 5 section variable ceramic	C411A, C411B, C411C, C411D, C411E	700, 826-003	917 5110 00 or 917N5A1
C411A	#	CAPACITOR: Section of C411	C410 trimmer		
C411B	#	CAPACITOR: Section of C411	C406 trimmer		
C411C	#	CAPACITOR: Section of C411	C409 trimmer		
C411D	#	CAPACITOR: Section of C411	C408 trimmer		
C411E	#	CAPACITOR: Section of C411	C407 trimmer		
C412	#	CAPACITOR: See C403	LFO grid coupling		
E401	#	BUSHING INSERT: 3/16 x 5/8	LFO HV feedthru	2410, Type BI	190 2932 00 or 190NBI7

TABLE OF REPLACEABLE PARTS  
 MODEL: AN/ART-13 RADIO TRANSMITTING EQUIPMENT MAJOR ASSEMBLY: LF OSCILLATOR TYPE 0-16/ART-13

Reference Symbol	Army Stock Number Navy Stock Number British Ref. Number	NAME OF PART and DESCRIPTION	FUNCTION	MFR. and DESIG. or AWS TYPE	CONT. or GOVT. DWG. or SPEC. No.
E402	#	CYL. STANDOFF: $\frac{3}{8} \times \frac{1}{2}$	LFO lead standoff	2410, 395-L- $\frac{1}{2}$	190 2329 00 or 190NSL5
L401	# (R) 16 C 27595-30	INDUCTOR: 45 turns close wound 48-38 litz wire	LFO grid tuning inductor	830, GA-1259C	571 1259 30 or 1259C
L402	# (R) 16 C CR 240N4A	CHOKE: 8 mh 0.125 amp 70 ohm	LFO feed choke	2140, CH-8; 3090	240 4100 00 or 240N4A
L403	#	CHOKE: Multi-section 2.5 uh 0.125 amp 50 ohm	LFO cathode choke	8220, R100-U; 3090	240 5300 00 or 240N53
P401	#	PLUG: 6 terminal connector chassis mtg	LFO connector plug	2580, Type 300	365 2060 00 or 365N206
R401	# (R) 16 R 17310-62	RESISTOR: 15,000 ohm $\pm 10\%$ 1 w	LFO grid	2360, BT1-Navy	729 7154 20 or 729NG15M-K
S401	#	SWITCH: Rotor assembly stator assembly	LFO frequency range sw	830, GA-1021A 830, GA-1544B	571 1021 10 or 1021A 571 1544 20 or 1544B
V401	16-T-12905	TUBE: Type 1625 beam pentode	LFO	* * 1625	254 0458 00
X401	# (R) 16 S 6182-33	SOCKET: 7 terminal base Isolantite	For V401	2570, 227	220 5730 00 or 220N573

TABLE OF REPLACEABLE PARTS

DUMMY LFO UNIT TYPE NX-128/ART-13  
 MAJOR ASSEMBLY: (Included in Transmitter Unit Type T-47/ART-13)

MODEL: AN/ART-13 RADIO TRANSMITTING EQUIPMENT

Reference Symbol	Army Stock Number Navy Stock Number British Ref. Number	NAME OF PART and DESCRIPTION	FUNCTION	MFR. and DESIG. or AWS TYPE	CONT. or GOVT. DWG. or SPEC. No.
P402, R402		DUMMY LOW FREQUENCY OSCILLATOR: A substitution for Type 0-16/ART-13 Low Frequency Oscillator		830	571 1300 30
P402		PLUG: 6 terminal connector chassis mtg	Dummy LFO connector plug	2580, Type 300	365 2060 00 or 365N206
R402		RESISTOR: 28 ohm $\pm 20\%$ 20 w	Filament substitute Alternate	2360, DG 3450	710 0001 00 710 1281 20 or 710NA28A-K

CONTRACT or ORDER No. NXsa-44558

MODEL: AN/ART-13 RADIO TRANSMITTING EQUIPMENT

MAJOR ASSEMBLY: PILOT'S CONTROL UNIT C-740/ART-13

Reference Symbol	NAME OF PART and DESCRIPTION	FUNCTION	MFR. and DESIG. or AWS TYPE	CONT. or GOVT. DWG. or SPEC. No.
601-699	PILOT'S CONTROL UNIT: A remote control unit containing an emission switch, a CHANNEL selector switch and an internally lighted plastic panel.		CTE	34267
I601	DIAL: Metal knob; plastic skirt; internally lighted.	Operates S601	CTE	34248
E603	KNOB: Rect metal; plastic skirt; internally lighted.	Operates S602	CTE	34247
E601	LIGHT, PANEL: 1 lamp; midjet flange base; 28v; brass shell, bakelite cap; shell nickel plated, cap dull black finish; mounted in 15/32" dia hole in 1/16" thick panel; 5/8" dia x 1-3/16" lg; 1 tubular solder terminal in center of base.	Illuminates A601	CCG A-4295 AN3502-1A	36263
E602	LIGHT, PANEL: Same as E601.			
A601	PANEL, PLASTIC: Internally lighted; black background, white markings; 5-3/4" wide x 2-1/4" long x 3/16" thick.	Covers mounting plate	Plasteck	34237
J601	RECEPTACLE: 27 male contacts; wall mounting.	Terminates wiring	630 Type K	371N401
S601	SWITCH, ROTARY: 1 circuit, non-shorting, 11 position.	Selects channel	3030	36271
S602	SWITCH, ROTARY: 2 circuit, shorting 4 position.	Selects channel	3030	36272

CONTRACT or ORDER No. NXsa-44558, NOcs 51-225

PAGE 20 of 52 PAGES



TABLE OF REPLACEABLE PARTS  
 MODEL: AN/ART-13 RADIO TRANSMITTING EQUIPMENT  
 MAJOR ASSEMBLY: PILOT'S CONTROL UNIT TYPE C-87/ART-13

Reference Symbol	Army Stock Number Navy Stock Number British Ref. Number	NAME OF PART and DESCRIPTION	FUNCTION	MFR. and DESIG. or AWS TYPE	CONT. or GOVT. DWG. or SPEC. No.
601-699		PILOT'S CONTROL UNIT: A remote Control Unit containing an EMISSION selector switch, a CHANNEL selector switch, a telegraph Key and a PILOT lamp		880, 314N-1	500 4414 00D
I601	(R) 17 L 6682	INDICATOR: 28 v clear bulb miniature bayonet base	Pilot's control unit pilot lamp	1881, T3-1/4	262 3270 00 or 262N327
E601		RECEPTACLE: Mounting bracket for bayonet base lamp, type 80	For I601	1200, 80	262 1270 00 or 262N127
J601		RECEPTACLE: 27 terminal wall mtg plug connector	Pilot's control unit connector plug receptacle	680, Type K	371 4010 00 or 371N401
J602	(R) 16 J 3258	RECEPTACLE: 3 circuit jack	Pilot's microphone cord plug receptacle	3080, SCA2B; 3240	358 1050 00 or 358N105
S601		SWITCH: 1 circuit non-shorting 11 position	Pilot's CHANNEL selector sw	3410	259 1421 00 or 259N142A
S602		SWITCH: 3 circuit, shorting 4 position	Pilot's Emission selector sw	3410	259 1362 00 or 259N136B
S603		SWITCH: Chassis mtg	Telegraph key	2050	274 1400 00 or 274N14

TABLE OF REPLACEABLE PARTS  
 MODEL: AN/ART-13 RADIO TRANSMITTING EQUIPMENT MAJOR ASSEMBLY: ANTENNA LOADING COIL TYPE CU-25/ART-13

Reference Symbol	Army Stock Number Navy Stock Number British Ref. Number	NAME OF PART and DESCRIPTION	FUNCTION	MFR. and DESIG or AWS TYPE	CONT. or GOVT. DWG. or SPEC. No.
701-799		ANTENNA LOADING COIL: An external loading coil used in connection with the Type 0-16/ART-13 LFO to extend the frequency range of the Type T-47/ART-13 Transmitter from 200 kc to 600 kc		830, 180H-1	520 1915 00
C701	# (R) 16 C 10071	CAPACITOR: .0008 mf $\pm 5\%$ 6000 TV	Loading coil input	911, 6LS	906 3801 10 or 906N380A-J
E701	#	PLUG: $\frac{7}{8} \times \frac{1}{8}$ ceramic bushing	"TRANSMITTER" terminal feedthru	830, X7007	507 7007 00 or X7007
E703	#	COUPLER: $\frac{1}{2} \times 1$ Isolantite	Variometer shaft coupler	830, X6146	507 6146 00 or X6146
E704	#	STANDOFF: $\frac{3}{8} \times 2-\frac{3}{4}$ Isolantite	S701 standoffs	830, X6193	507 6193 00 or X6193
E706	#	BOWL: Ceramic	Antenna feedthru bowl	830, X7009	507 7009 00 or X7009
J701	#	RECEPTACLE: Connector	"TRANSMITTER" terminal	1320	372 2900 00 or 372N29
J702	# (R) 16 P 5316	RECEPTACLE: Connector	"GROUND" terminal	1320	372 1410 00 or 372N14A
J703	# (R) 16 P 5321	RECEPTACLE: Connector	"ANTENNA" terminal	1320	372 2510 00 or 372N25A
L701	# (R) 16 C CR 240N59	CHOKE: Multi-section 6 mh 21 ohms	Static drain choke	950	240 5900 00 or 240N59
L702	# (R) 16 V CR-GA-1312-B	INDUCTOR: Variometer	PA tuning inductor	830, GA-1312B	571 1312 20 or 1312B
L703	# (R) 16 C 21394	INDUCTOR: Tapped	Antenna loading inductor	830, GA-1304B	571 1304 20 or 1304B
S701	#	SWITCH: 13 position tap	Frequency range sw	830, GA-1303B	571 1303 20 or 1303B

TABLE OF REPLACEABLE PARTS  
 MODEL: AN/ART-13 RADIO TRANSMITTING EQUIPMENT MAJOR ASSEMBLY: ANTENNA LOADING COIL TYPE CU-26/ART-13

Reference Symbol	Army Stock Number Navy Stock Number British Ref. Number	NAME OF PART and DESCRIPTION	FUNCTION	MFR. and DESIG. or AWS TYPE	CONT. or GOVT. DWG. or SPEC. No.
801-899		ANTENNA LOADING COIL: An external loading coil used in connection with the Type 0-16/ART-13 LFO to extend the frequency range of the Type T-47/ART-13 Transmitter from 500 kc to 1500 kc		830, 180H-2	520 1906 00
C801	# (R) 16 C 10013	CAPACITOR: .0004 mf $\pm$ 5% 5000 TV	Loading coil input	911, 6LS	906 3401 10 or 906N340A-J
E801	#	PLUG: Ceramic bushing	"ANTENNA" & "TRANSMITTER" terminal feedthrus	830, X7008	507 7008 00 or X7008
E803	#	COUPLER: $\frac{1}{2}$ x 1 Isolantite	L802 & S801 insulating shaft	830, X6146	507 6146 00 or X6146
E804	#	STANDOFF: $\frac{3}{8}$ x 2 Isolantite	S801 stator support	830, X6158	507 6158 00 or X6158
J801	#	CONNECTOR	"TRANSMITTER" terminal	1320	372 2900 00 or 372N29
J802	# (R) 16 P 5316	CONNECTOR	"GROUND" terminal	1320	372 1410 00 or 372N14A
J803	#	CONNECTOR: See J801	"ANTENNA" terminal		
L801	# (R) 16 C CR-240N59	CHOKER: Multi-section 6 mh 21 ohms	Static drain choke	950	240 5900 00 or 240N59
L802	# (R) 16 V CR-GA-1265-B	INDUCTOR: Variometer & tapped	PA plate tuning & antenna loading in- ductor	830, GA-1265B	571 1265 20 or 1265B
S801	#	SWITCH: 7 position tap	Frequency range switch	830 GA-940C	571 0940 30 or 940C

**TABLE OF REPLACEABLE PARTS**  
**MODEL: AN/ART-13 RADIO TRANSMITTING EQUIPMENT**      **MAJOR ASSEMBLY: ANTENNA SHUNT CAPACITOR TYPE CU-24/ART-13**

Reference Symbol	Army Stock Number Navy Stock Number British Ref. Number	NAME OF PART and DESCRIPTION	FUNCTION	MFR. and DESIG. or AWS TYPE	CONT. or GOVT. DWG. or SPEC. No.
C1101-C1199		ANTENNA SHUNT CAPACITOR: Three capacitors mounted on a plate to be used as required in increasing the Transmitter Antenna tuning network capacity		830, 195D-1	500 4232 00B
C1101		CAPACITOR: 25 mmf ±10% 10,000 TV RMS	Antenna shunt	30, 1860-201	914 1762 00 or 914N1X6-K
C1102		CAPACITOR: See C1101	Antenna shunt		
C1103		CAPACITOR: See C1101	Antenna shunt		
<b>TRANSMITTER CONTROL PLUGS</b>					
P1201	(R) 17 P 4436-516-75	PLUG: 27 terminal straight male	Connector	630, RNK-27-22C-11/16	371 4049 00 or 371N404R
P1202	(R) 17 P 4436-468-100	PLUG: 27 terminal straight female	Connector	630, NK-27-21C-11/16	371 4020 00 or 371N402
<b>POWER PLUGS</b>					
P1301	(R) 17 P 4436-200	PLUG: 10 terminal straight female	Connector	630, FK-10-21C-9/16	371 5140 00 or 371N514
P1302	(R) 17 P 14436-516-25	PLUG: 10 terminal right angle male	Connector	630, RFK-10-24C-9 16	371 5129 00 or 371N512R
<b>DYNAMOTOR POWER UNIT INPUT PLUG</b>					
P1401	(R) 17 P 4436-413	PLUG: 3 terminal right angle female	Connector	630, GK-C3-23C-1/2	371 2170 00 or 371N217

**TABLE OF REPLACEABLE PARTS**  
**MODEL: AN/ART-13 RADIO TRANSMITTING EQUIPMENT**      **MAJOR ASSEMBLY: CONTROL UNIT**  
**DYNAMOTOR POWER UNIT TYPE DY-12/ART-13**

Reference Symbol	Army Stock Number Navy Stock Number British Ref. Number	NAME OF PART and DESCRIPTION	FUNCTION	MFR. and DESIG. or AWS TYPE	CONT. or GOVT. DWG. or SPEC. No.
2101-2199		DYNAMOTOR POWER UNIT: Power control unit including Wincharger dynamotor to furnish all voltages necessary for the operation of the Type T-47/ART-13 Transmitter		830, 416U-2	500 6627 00E
C2101	(R) 16 C 11312-2	CAPACITOR: 0.1 mf $\pm 20\%$ 600 WV	Transient suppressor	1640; 3030	930 0007 00
C2102	(R) 16 C 11567	CAPACITOR: 4.0 mf $\pm 20\%$ 50 WV	Supply voltage filter	1640; 3030	930 0005 00
C2103	(R) 16 C 11712-310	CAPACITOR: 2.0 mf $\pm 20\%$ 600 WV	Spark suppressor	911, KG-3020; 1640, A7649; 1881, 67X2	930 7824 00 or 930N78B-M
C2104	(R) 16 C 11239	CAPACITOR: 3-0.1 mf $\pm 20\%$ 600 WV	C2104A, C2104B, C2104C	911; 4210; 4250	956 0002 00
C2104A		CAPACITOR: Section of C2104	RF bypass		
C2104B		CAPACITOR: Section of C2104	Low voltage filter		
C2104C		CAPACITOR: Section of C2104	RF bypass		
C2105	(R) 16 C 11325-60	CAPACITOR: 0.1 mf $\pm 20\%$ 1500 WV	High voltage filter	3030; 1640	930 0003 00
C2111		CAPACITOR: See C2104	C2111A, C2111B, C2111C		
C2111A		CAPACITOR: Section of C2111	RF bypass		
C2111B		CAPACITOR: Section of C2111	RF bypass		
C2111C		CAPACITOR: Section of C2111	RF bypass		
C2112	(R) 16 C 11312-5	CAPACITOR: 0.1 mf $\pm 20\%$ 600 WV	Supply voltage filter	1640; 3030	930 0011 00

CONTRACT or ORDER No. NXsa-44558

PAGE 25 of 52 PAGES

**TABLE OF REPLACEABLE PARTS**  
**MODEL: AN/ART-13 RADIO TRANSMITTING EQUIPMENT**      **MAJOR ASSEMBLY: CONTROL UNIT**      **DYNAMOTOR POWER UNIT TYPE DY-12/ART-13**

Reference Symbol	Army Stock Number Navy Stock Number British Ref. Number	NAME OF PART and DESCRIPTION	FUNCTION	MFR. and DESIG. or AWS TYPE	CONT. or GOVT. DWG. or SPEC. No.
C2113	(R) 16 C 11443	CAPACITOR: 1.3 mf $\pm 20\%$ 50 WV	Supply voltage filter	3030; 1640	930 0004 00
C2114	(R) 16 C 11312	CAPACITOR: 0.1 mf $\pm 10\%$ 600 WV	Low voltage filter	1640; 3030	930 0006 00
C2115		CAPACITOR: 4.0 mf $\pm 20\%$ 600 WV	Low voltage filter	911, KG-3040; 1640, A7650; 1881, 67X5	930 0001 00
C2116	(R) 16 C 11289	CAPACITOR: 2.0 mf $\pm 20\%$ 1500 WV	High voltage filter	911 1881, T-15020	930 0002 00
C2117		CAPACITOR: See C2114	High voltage filter		
E2102A		RECEPTACLE: Type 1605B fuse mtg block	For F2101	830, 1605B	571 1605 20 or 1605B
E2102B		RECEPTACLE: Type 1606B fuse cover	Cover for receptacle E2102A	830, 1606B	571 1606 20 or 1606B
F2101	(R) 17 F 14245	FUSE: 250 v 1 amp cartridge fuse 1- $\frac{1}{4}$ x 9/32 inch	LV secondary	2920 4AG	264 5010 00 or 264N501
J2101	(R) 17 R 1977-10	RECEPTACLE: 10 terminal wall mtg	Dynamotor supply connector plug re- ceptacle	630, RPK-10-31SL	371 5119 00 or 371N511R
J2102	(R) 17 R 1965-48	RECEPTACLE: 3 terminal connector wall mounting	Dynamotor input plug receptacle	630, GK-C3-32S	371 2010 00 or 371N201
K2101	(R) 16 R 5685-115	RELAY: Single pole normally open contacts	Dynamotor input control	2050, G-31199	401 7900 00 or 401N79
K2102	(R) 16 R 5685-125	RELAY: 1 pole normally open double break circuit control	Primary power contactor	2050, G-32793	405 2202 00 or 405NB202

**TABLE OF REPLACEABLE PARTS**  
**DYNAMOTOR POWER UNIT TYPE DY-12/ART-13**  
**MODEL: AN/ART-13 RADIO TRANSMITTING EQUIPMENT MAJOR ASSEMBLY: CONTROL UNIT**

Reference Symbol	Army Stock Number Navy Stock Number British Ref. Number	NAME OF PART and DESCRIPTION	FUNCTION	MFR. and DESIG. or AWS TYPE	CONT. or GOVT. DWG. or SPEC. No.
K2103		RELAY: 10 amp 28 v dc single circuit	Transmitter power overload	4234, PM10	260 4560 00 or 260N456
K2104		RELAY: 40 amp 28 v dc single circuit	Dynamotor primary power overload	4234, PM40	260 4550 00 or 260N455
K2105	(R) 16 R 5069-20	RELAY: 2 PDT circuit control	Power change Alternate	257, R-22B 2050 2050, G-33375	410 3013 00 410 0014 00 410 2000 00 or 410N20
K2106	(R) 17 S 25171	RELAY: SPDT barometric circuit control switch	Voltage control	1884, CR2927	260 4570 00 or 260N457
L2101	(R) 16 C 17183-5	CHOKE: 5.5 uh spiral wound low resistance	Supply voltage filter choke	1640	240 0003 00
L2102	(R) 16 C 17184-15	CHOKE: Multi-section duo-lateral wound 1.0 mh, 0.3 amp 10 ohms	Low voltage filter choke	3220, R-300U; 3090	240 5800 00 or 240N58
L2103		CHOKE: See L2102	High voltage filter choke		
L2104		CHOKE: See L2102	High voltage filter choke		
L2105	(R) 16 C 17183	CHOKE: 5.5 uh spiral wound low resistance	Supply voltage filter choke	1640	240 0002 00
L2106	(R) 16 C 17184	CHOKE: 0.5 mh 0.75 amp 3 section duo-lateral	Low voltage filter choke	3090	240 0004 00
L2107		CHOKE: See L2106	Low voltage filter choke		
L2108		CHOKE: See L2102	High voltage filter choke		

**TABLE OF REPLACEABLE PARTS**  
**DYNAMOTOR POWER UNIT TYPE DY-12/ART-13**  
**MODEL: AN/ART-13 RADIO TRANSMITTING EQUIPMENT**      **MAJOR ASSEMBLY: CONTROL UNIT**

Reference Symbol	Army Stock Number Navy Stock Number British Ref. Number	NAME OF PART and DESCRIPTION	FUNCTION	MFR. and DESIG. or AWS TYPE	CONT. or GOVT. DWG. or SPEC. No.
L2109		CHOKE: See L2102	High voltage filter choke		
L2110		CHOKE: See L2102	High voltage filter choke		
R2101	(R) 16 R 17258-58-2	RESISTOR: 47 ohm $\pm 20\%$ 1 w	Spark suppressor	4230	729 7474 00 or 729NG47-M
R2102		RESISTOR: 20.1 ohm, tapped at 13.4 ohm $\pm 5\%$ 0.5 amp	Voltmeter multiplier	3450	717 4100 00 or 717ND1
R2104	(R) 16 R 17263-18-3	RESISTOR: 330 ohm $\pm 20\%$ 1 w	Spark suppressor	2360, BW1-Navy	708 3305 24 or 708N330NB-M

**CONTRACT or ORDER No. NXsa-44558**

**PAGE 28 of 52 PAGES**



**TABLE OF REPLACEABLE PARTS**  
**DYNAMOTOR POWER UNIT TYPE DY-12/ART-13**  
**MAJOR ASSEMBLY: DYNAMOTOR**

Reference Symbol	Army Stock Number Navy Stock Number British Ref. Number	NAME OF PART and DESCRIPTION	FUNCTION	MFR. and DESIG. or AWS TYPE	CONT. or GOVT. DWG. or SPEC. No.
D2101	(R) 16 D 5560-325	DYNAMOTOR: Input: 27 v 32 amp dc Output number 1: 400 v 0.75 amp dc Output number 2: 750 v 0.35 amp dc	Dynamotor	4960, 51S1	231 0004 00 or 231N47A
C2106	(R) 16 C 10401-15	CAPACITOR: .005 mf $\pm 20\%$ 1000 TV	Motor brush spark suppressor	911, 3WLS; 4030, JLS; 4210, MKBW	909 2506 40 or 909N250F-M
C2107		CAPACITOR: See C2106	Motor brush spark suppressor		
C2108	(R) 16 C 10451	CAPACITOR: .006 mf $\pm 20\%$ 5000 TV	Low voltage filter	911, 9LS; 4030, A2LS	950 2601 14 or 950N260A1-M
C2109		CAPACITOR: See C2108	High voltage filter		
C2110		CAPACITOR: See C2108	High voltage filter		
E2101A	(R) 16 B 12226-20	BRUSH: For dynamotor for 231 0004 00 or 231N47A	+ Input brush	4960	234 1281 00 or 234N128A
E2101B	(R) 16 B 12226-26	BRUSH: For dynamotor for 231 0004 00 or 231N47A	- Input brush	4960	234 1291 00 or 234N129A
E2101C	(R) 16 B 12226-17	BRUSH: For dynamotor for 231 0004 00 or 231N47A	+ LV brush	4960	234 1261 00 or 234N126A
E2101D	(R) 16 B 12226-18	BRUSH: For dynamotor for 231 0004 00 or 231N47A	- LV brush	4960	234 1271 00 or 234N127A
E2101E	(R) 16 B 12226-12	BRUSH: For dynamotor for 231 0004 00 or 231N47A	+ HV brush	4960	234 1241 00 or 234N124A
E2101F	(R) 16 B 12226-16	BRUSH: For dynamotor for 231 0004 00 or 231N47A	- HV brush	4960	234 1251 00 or 234N125A

**TABLE OF REPLACEABLE PARTS**

**RADIO TRANSMITTER TYPE T-47/ART-13**

**MAJOR ASSEMBLY: MCW-C.1 UNIT**

Reference Symbol	Army Stock Number Navy Stock Number British Ref. Number	NAME OF PART and DESCRIPTION	FUNCTION	MFR. and DESIG. or AWS TYPE	CONT. or GOVT. DWG. or SPEC. No.
C2201	(R) 16 C 11239	CAPACITOR: .006 mf $\pm 60\%$ —20% 600 WV	Calibration oscillator tripler coupling	911, ASA; CN35A602	934 0002 00
C2202		CAPACITOR: See C2201	Calibration oscillator tripler grid coupling		
C2203		CAPACITOR: See C2201	Calibration oscillator mixer grid coupling		
C2204		CAPACITOR: 200 mmf $\pm 5\%$ 1000 TV	Calibration oscillator detector grid coupling	4170, ASA; CM20B201-J	935 0118 00
C2205	(R) 16 C 9807-25	CAPACITOR: 10 mmf $\pm 10\%$ 1000 TV	Calibration oscillator input HFO	911, 5WS; 4080, KS; 4210, MO; 30, 1468	909 4107 52 or 909N410GN-K
C2206		CAPACITOR: See C2205	Calibration oscillator input LFO		
C2207		CAPACITOR: .05 mf $\pm 10\%$ —10% 600 WV	Calibration oscillator decoupling	1640	930 0010 00
C2208		CAPACITOR: See C2207	Calibration oscillator mixer screen decoupling		
C2209		CAPACITOR: See C2207	Calibration oscillator output coupling		
C2210		CAPACITOR: See C2207	Audio oscillator grid tank		
C2211	(R) 16 C 11709-310	CAPACITOR: .5 mf $\pm 20\%$ 600 WV	HV supply filter	911, DYR-6050; 4210, XDMR6-.5; 1640, A7178	956 0006 00 or 956NS08YX1-M

**TABLE OF REPLACEABLE PARTS**  
**RADIO TRANSMITTER TYPE T-47//ART-13**  
**MAJOR ASSEMBLY: MCW-CFI UNIT**

Reference Symbol	Army Stock Number Navy Stock Number British Ret. Number	NAME OF PART and DESCRIPTION	FUNCTION	MFR. and DESIG. or AWS TYPE	CONT. or GOVT. DWG. or SPEC. No.
C2212	(R) 16 C 11333-98	CAPACITOR: 2-.1 mf $\pm 20\%$ 600 WV	C2212A, C2212B	911, DYRT-6011; 4210, 2XDRTMW6 -1 4250, 2527-9	956 0008 00 or 956ND01WX1-M
C2212A		CAPACITOR: Section of C2212	Audio oscillator blocking		
C2212B		CAPACITOR: Section of C2212	Audio oscillator tank tuning		
C2213		CAPACITOR: 30 mmf $\pm 5\%$ 500 WV	Oscillator feedback Alternate	ASA: CM20C300 911, 5R	935 0144 00 912 4803 10 or 912N430C-J
C2214		CAPACITOR: .005 mf $\pm 5\%$ 1000 TV	RF Bypass Alternate	ASA: CM35B512 ASA: CM40B512	935 2105 00 935 3035 00
L2201	(R) 16 C CR 678N247	INDUCTOR: .25 hy 1000 cps & .1 mf capacitor	Audio oscillator grid tank inductor	780, 7822	678 2470 00 or 678N247
P2201		PLUG: 8 term connector	MCW-CFI unit con- nector plug	2580, 300	865 0002 00
R2201	(R) 16 R 23170	RESISTOR: 2-15 ohm WW Rheostat	Audio oscillator output control	4975	881 9010 00 or 381N901
R2202	(R) 16 R 17347-15	RESISTOR: 100,000 ohm $\pm 10\%$ $\frac{1}{2}$ w	Calibration oscillator decoupling	2360, BT $\frac{1}{2}$ -Navy	729 5100 42 or 729NE100M-K
R2203		RESISTOR: 47,000 $\pm 10\%$ $\frac{1}{2}$ w	Calibration oscillator tripier grid	2360, BT $\frac{1}{2}$ -Navy	729 5474 20
R2204		RESISTOR: 150,000 ohm $\pm 10\%$ $\frac{1}{2}$ w	Audio oscillator grid coupling	2360, BT $\frac{1}{2}$ -Navy	729 5150 42 or 729NE150M-K

**TABLE OF REPLACEABLE PARTS**

**MODEL: AN/ART-13 RADIO TRANSMITTING EQUIPMENT**

**RADIO TRANSMITTER TYPE T-47/ART-13**

**MAJOR ASSEMBLY: MCW-CFI UNIT**

Reference Symbol	Army Stock Number Navy Stock Number British Ref. Number	NAME OF PART and DESCRIPTION	FUNCTION	MFR. and DESIG. or AWS TYPE	CONT. or GOVT. DWG. or SPEC. No.
R2205		RESISTOR: 47,000 ohm $\pm 10\%$ $\frac{1}{2}$ w	Calibration oscillator mixer injection grid	2360, BT $\frac{1}{2}$ -Navy	729 5474 20 or 729NE47M-K
R2206		RESISTOR: See R2205	Calibration oscillator mixer control grid	3450	710 0003 00
R2207	(R) 16 R 17260-44-150	RESISTOR: 85 ohm $\pm 2\frac{1}{2}\%$ 10 w	Calibration oscillator mixer filament dropping	2360, BT $\frac{1}{2}$ -Navy	729 5334 20 or 729NE33M-K
R2208		RESISTOR: 33,000 ohm $\pm 10\%$ $\frac{1}{2}$ w	Calibration oscillator decoupling	2360, BT1-Navy	729 7154 20 or 729NG15M-K
R2209	(R) 16 R 17310-62	RESISTOR: 15,000 ohm $\pm 10\%$ 1 w	Calibration oscillator screen dropping	3450	710 0010 00
R2210		RESISTOR: 15,000 ohm $\pm 10\%$ 10 w	Calibration oscillator HV dropping	2360, BT1-Navy	729 7220 42
R2211		RESISTOR: 220,000 ohm $\pm 10\%$ 1 w	Audio oscillator HV dropping		
R2212		NOTE: R2212A and R2212B are connected in parallel to provide the resistor of 68,000 ohms one watt itemized on all schematic diagrams as R2212. Replacement of these paralleled resistors with a single 68,000 ohm one watt resistor will be satisfactory in every way.			
R2212A		RESISTOR: See R2202	Audio oscillator HV bleeder		
R2212B		RESISTOR: 220,000 ohm $\pm 10\%$ $\frac{1}{2}$ w	Audio oscillator HV bleeder	2360, BT $\frac{1}{2}$ -Navy	729 5220 42
R2213	(R) 16 R 17354-14-200	RESISTOR: 470,000 ohm $\pm 10\%$ $\frac{1}{2}$ w	Calibration oscillator detector grid	2360, BT $\frac{1}{2}$ -Navy	729 5470 42 or 729NE470M-K

**TABLE OF REPLACEABLE PARTS**  
**RADIO TRANSMITTER TYPE T-47/ART-13**  
**MAJOR ASSEMBLY: MCW-CFI UNIT**

Reference Symbol	Army Stock Number Navy Stock Number British Ref. Number	NAME OF PART and DESCRIPTION	FUNCTION	MFR. and DESIG. or AWS TYPE	CONT. or GOVT. DWG. or SPEC. No.
R2214		RESISTOR: See R2213	Calibration oscillator detector decoupling		
R2215		RESISTOR: 2200 ohm $\pm 5\% \frac{1}{2} w$	Audio oscillator output loading	2360, BT $\frac{1}{2}$ -Navy	729 5220 01 or 729NE2200-J
R2216		RESISTOR: See R2204	Calibration oscillator grid		
R2217		RESISTOR: 220 ohm $\pm 20\% \frac{1}{2} w$	Calibration oscillator mixer cathode Alternate Alternate	2360, BW $\frac{1}{2}$	707 2205 40 729 0001 00 708 2205 40
V2201		TUBE: Dual triode 12SL7GT	Calibration oscillator crystal oscillator tripler	* * 12SL7GT	254 0258 00
V2202		TUBE: Pentagrid convert 12SA7, 12SA7GT/G	Calibration oscillator mixer	* * 12SA7, 12SA7GT/G	254 0248 00
V2203		TUBE: See V2201	Calibration oscillator detector—audio oscillator		
X2201	(R) 16 S 4671-5	SOCKET: 8 terminal octal tube	For V2201	220, 88-8	220 1850 00 or 220N185
X2202		SOCKET: See X2201	For V2202		
X2203		SOCKET: See X2201	For V2203		
X2204		SOCKET: 2 terminal crystal	For Y2201	810, 9816	292 0012 00
Y2201		QUARTZ CRYSTAL: Mounted in holder	Calibration oscillator quartz crystal	4870	291 0002 00
Z2201	(R) 16 C 27595-64	TUNED CIRCUIT: Coil assembly	Z2201A, Z2201B	70	278 0001 00

**TABLE OF REPLACEABLE PARTS**  
**RADIO TRANSMITTER TYPE T-47/ART-13**  
**MAJOR ASSEMBLY: MCW-CFI UNIT**

Reference Symbol	Army Stock Number Navy Stock Number British Ref. Number	NAME OF PART and DESCRIPTION	FUNCTION	MFR. and DESIG. or AWS TYPE	CONT. or GOVT. DWG. or SPEC. No.
Z2201A		TUNED CIRCUIT: Section of Z2201	Calibration oscillator crystal oscillator grid tank		
Z2201B		TUNED CIRCUIT: Section of Z2201	Calibration oscillator detector cathode tank		
Z2202	(R) 16 C 27595-68	TUNED CIRCUIT: Assembly coil	Z2202A, Z2202B	70	278 0002 00
Z2202A		TUNED CIRCUIT: Section of Z2202	Calibration oscillator tripler tank		
Z2202B		TUNED CIRCUIT: Section of Z2202	Calibration oscillator mixer tank		

**CONTRACT or ORDER NO. NXsa-44558**

**PAGE 34 of 52 PAGES**

TABLE OF REPLACEABLE PARTS  
 MODEL: AN/ART-13A TRANSMITTING EQUIPMENT MAJOR ASSEMBLY: ANTENNA LOADING UNIT CU-32/ART-13A

Reference Symbol	Army Stock Number Navy Stock Number British Ref. Number	NAME OF PART and DESCRIPTION	FUNCTION	MFR. and DESIG. or AWS TYPE	CONT. or GOVT. DWG. or SPEC. No.
901-999		ANTENNA LOADING COIL: An external loading coil used to extend the frequency range of the Type T-47A/ART-13 Transmitter from 200 kc to 600 kc.			
C2501	3K7036123 R16 C 10003-109-100	CAPACITOR: Fixed; mica; 360 uuf $\pm$ 2%; 5000 volts DCW; 3-9/64" x 2 1/4" molded; two 0.180" dia. mounting holes 2.625" between mtg/c; two No. 10-32 terminal studs.	M2501 meter coupling capacitor	JAN Type CM70B361G	
C2502	3K7056123 R16 C 10029-31-828	CAPACITOR: Fixed; mica; 560 uuf $\pm$ 2%; 5000 volts DCW; 3-9/64" x 2 1/4" x 1-17/64" molded; two 0.180" dia. mounting holes 2.625" between mtg/c; two No. 10-32 terminal studs.	M2501 meter coupling capacitor	JAN Type CM70B561G	
E2501	2Z9406.132 R16-USAF 47B 47346	BOARD TERMINAL: Less resistors R2501 through R2505; bakelite 4 3/4" x 1 7/8" x 1/8"; complete with 6 terminals.	Mounting board for Resistors R2501 thru R2505	CBHT, 263-137	USAF 47B 47346
E2502	3G1250-12.19 R16 I 9791	STAND-OFF INSULATOR: Ceramic 3/4" x 3/8" dia.; tapped No. 6-32 axial mounting hole at each end.	Resistor board mounting supports	JAN Type NS4W0106	
E2503	3Z3269-34 R16-USAF-47B 47342	COUPLING: Ceramic ring; two metal hubs each with two set screws.	Insulated coupling between variometer	CBHT, 263-136	USAF 47B 47342
E2504	2Z9402.215 R16-USAF-47B 47350	FEED-THROUGH ASSEMBLY: Antenna, consisting of a 9" x 6" x 1/8" mycalex plate, and binding posts J2506 and J2507.	Antenna Posts	CBHT, 263-103	USAF 47B 47350
E2505	3G1905-2 R16-USAF-47B 47355	FEED-THROUGH ASSEMBLY: Supplied with binding post J2503; ceramic; 3 3/8" dia. x 1" thk. three 0.154" dia. mtg. holes; bowl shape.	HF Input Terminal	CBHT, 263-110	USAF 47B 47355
E2506		FEED-THROUGH, INSULATOR ASSEMBLY: Consists of E2506-R and E2506-B.			
E2506-A	3G1000-4.1	FEED-THROUGH INSULATOR: Ceramic female; 1/2" high; top dia. 3/4" bottom dia. 7/8".	Female insulator used with binding post J2502	700, X-88W	
E2506-B	3G100-56.1 R16-USAF-47B 47351	FEED-THROUGH, INSULATOR: Ceramic; male; 7/8" x 7/8" max. dia.	Male Insulator used with binding post		USAF 47B 47351

CONTRACT or ORDER NO. AF-33(038) - 26820

PAGE 34.1 of 52 PAGES

**TABLE OF REPLACEABLE PARTS**  
**MODEL: AN/ART-13A TRANSMITTING EQUIPMENT**      **MAJOR ASSEMBLY: ANTENNA LOADING UNIT CU-32/ART-13A**

Reference Symbol	Army Stock Number Navy Stock Number British Ref. Number	NAME OF PART and DESCRIPTION	FUNCTION	MFR. and DESIG. or AWS TYPE	CONT. or GOVT. DWG. or SPEC. No.
E2508	2Z5786.37 R16-USAF-47B 47360	KNOB: Complete with two set screws; bakelite 2 1/4" x 13/16"; black finish with white arrow.	Knob for S2501 control "Q"		USAF 47B 47360
E2509	2Z5822-125 R16-USAF-47B 47331	KNOB: Complete with two set screws; less dial. 1" thk. x 2" dia.; bakelite, black.	Knob for L2501 control "R"		USAF 47B 47331
E2510	3G1100-74.1 R16-USAF-47A 47365	STAND-OFF: Ceramic; 3-15/32" x 1/2" x 1/2"; one axial tapped No. 10-24 mounting hole on one end; one 0.196" radial mounting hole 5/16" from other end; 4 used; part of L2502.	L2502 mounting insulators		USAF 47A 47365
E2511	3G110026.3 R16-USAF-47A 47364	STAND-OFF: Ceramic; 1 5/8" x 3/8" x 3/8"; one axial tapped No. 8-32 mounting hole one end; one 0.196" radial mounting hole 7/32" from other end; part of L2502.	L2502 mounting insulators		USAF 47A 47364
E2512	3G1100-104.4 R16-USAF-47A 47470	STAND-OFF: Ceramic; 5 7/8" x 1/2" x 1/2"; one axial tapped No. 8-32 and two radial 0.173" mounting holes on one end; two radial 0.196" mounting holes on other end; part of relay K2501.	Insulator between S2504 and relay K2501		USAF 47A 47470
E2513	3G1100-100	STAND-OFF: Ceramic; 6 1/4" x 1/2" x 1/2"; axial, tapped No. 8-32 mounting hole on one end; 0.150" radial hole, 1/4" from other end.	S2503 support post		
E2514		STAND-OFF: Ceramic; 1" x 3/8" x 3/8"; axial, tapped No. 8-32 mounting hole at each end, part of L2501.	H. V. Input conductor support		
E2515	3G1200-32.3 R16-USAF-47B 47343	RING: Ceramic; O.D. 2"; I.D. 1 1/4"; 1/4" thk; two 0.154" dia. mounting holes; two tapped No. 6-32 mounting holes.	Used on L2501 knob mechanism		USAF 47B 47343
E2516	2Z5786.37	KNOB: Same as E2508.	Knob for S2502 control "P"		
E2517	2Z5786.37	KNOB: Same as E2508.	Knob for S2503 control "D"		
E2518		SHAFT ASSEMBLY: Supplied with spring; 4-27/32" long; bakelite rod-between end pieces.	Connecting rod between S2504 and relay K2501	CBHT, 263-141	USAF 47B 47440



TABLE OF REPLACEABLE PARTS  
 MAJOR ASSEMBLY: ANTENNA LOADING UNIT CU-32/ART-13A

Reference Symbol	Army Stock Number Navy Stock Number British Ref. Number	NAME OF PART and DESCRIPTION	FUNCTION	MFR. and DESIG. or AWS TYPE	CONT. or GOVT. DWG. or SPEC. No.
E2519	R16-USAF-47B 47329	KNOB: Black composition, brass shaft, 1 3/8" x 3/8" dia. shaft threaded No. 10-24 thread.	Lock Knob		USAF 47B 47329
E2520	2Z8609-11	SNAP SLIDE: Stainless steel 1-15/32" long x 3/16" wide x 1/2" high; consists of 1 latch, 1 latch guide, rivet, 1 washer.			
E2521	3G1450-16.1 R16-USAF-47A 47264	STAND-OFF: 1 5/8" x 1/2" x 1/2"; 2 axial tapped 8-32 mtg. holes at each end.			USAF 47A 47264
E2522	3G1100-33 R16-USAF-47A 47362	STAND-OFF: ceramic; 2-1/16" x 1/2" x 1/2"; 8-32 axial tapped hole at one end; 0.196" radial hole approx. 1/4" from other end.			USAF 47A 47362
E2523	3G1450-16	STAND-OFF: ceramic.			
H2501		VERNIER MECHANISM: 1-11/64" x 2-9/16" dia.	Variometer speed reducer	JAN Type NS4U1008 3220	
H2502	R16 I 9791	COUPLER: 2" x 1/2" x 13/32" thk.	Used with insulated coupler		
J2501	2Z8673-42	CONNECTOR: Male; three contacts; wall mounting; two No. 10 contacts; one No. 16 contact; four 0.120" mounting holes, 0.729" between mtg/c; screw cable connector lock.	28 volt connection for K2501	630, WK-C3 32S-3	
J2502	3Z741-13	POST, BINDING: Same as J-117.	L. F. INPUT terminal		Signal Corps SO-239
J2503	3Z741-13.2	POST, BINDING: Same as J-110.			
J2504	3Z737-32	POST, BINDING: Same as J-113.			
J2505	2Z8799-239	CONNECTOR: Female; 1" x 1-1/16" thk., four 0.120" dia. mounting holes.		200, 83-1R	
J2506		POST, BINDING: Push type; black bakelite cap; keyed pin; 1-3/16" x 3/8" dia.; supplied with E2504.	Antenna Post	1320, 63K	
J2507		POST, BINDING: Same as J2506.			
K2501	2Z7598-52 R16-USAF-47G	RELAY: Supplied with S2504, E2512 and E2514; two coils connected in series used;	Antenna load connecting relay	CBHT, 263-106	USAF 47G 47439

CONTRACT or ORDER NO. AF-33(038) - 26820 PAGE 34.3 of 52 PAGES

**TABLE OF REPLACEABLE PARTS**  
**MAJOR ASSEMBLY: ANTENNA LOADING UNIT CU-32/ART-13A**

Reference Symbol	Army Stock Number Navy Stock Number British Ref. Number	NAME OF PART and DESCRIPTION	FUNCTION	MFR. and DESIG. or AWS TYPE	CONT. or GOVT. DWG. or SPEC. No.
L2501	47439 2Z9629-37 R16-USAF-47G 47369	nominal voltage 28 volts; coil resistance 26.1 ohms; approx. 5" wide x 8" high x 2 1/2" thk.; switch under S2504. VARIOMETER ASSEMBLY: Consists of rotor stator and coupling coil; approx. 9 1/2" x 4-9/16" dia; bakelite coil forms.	Antenna Loading	Islip, 47G47369	USAF 47G 47369
L2502	3C1075-3 R16-USAF-47D 47391	COIL, R.F. Single Winding; three taps, bank wound; 240 turns; mica tubing; supplied with support insulators; approx. 7" x 4 1/4" x 5" high.	Antenna Loading	Islip, 47D47391	USAF 47D 47391
M2501	3F1005-51	METER: Ammeter, thermo R.F., 0-5 amperes, 2 1/2" round.	Antenna loading meter	JAN Type MR25B005RLAA	
N2501	R16-USAF-47B 47330	DIAL: Aluminum; 2 1/2" dia.; one half of dial calibrated 0-100; six 1/8" dia. mounting holes.	Variometer dial	CBHT, 263-119	USAF 47B 47330
N2502		DISC ASSEMBLY: Semi-circular; 3" dia. x 1/4" thick.	Part of dial mechanism		USAF 47A 47333
R2501	3RC21BF185K	RESISTOR: Fixed; carbon 1 watt; 1.8 meg-ohms $\pm$ 10% max. dimensions 1.280" x 0.310" dia.; 1 1/2" axial wire leads.	Capacitor discharging network	JAN Type RC31BF185K	
R2502	3RC21BF185K	RESISTOR: Same as R2501.	Capacitor discharging network		
R2503	3RC21BF185K	RESISTOR: Same as R2501.	Capacitor discharging network		
R2504	3RC21BF185K	RESISTOR: Same as R2501.	Capacitor discharging network		
R2505	3RC21BF185K	RESISTOR: Same as R2501.	Capacitor discharging network		
S2501	3Z9826-54.2 R16-USAF 47D47480	SWITCH: Two bank; four position; switch body approx. 5-31/32" x 2 3/4" dia. thread tapped No. 6-32 mounted bushings; operated by control "Q".	Variometer Switch	CBHT, 263-103	USAF 47D 47480
S2502	3Z9826-54.1 R16-USAF- 47D47400	SWITCH: Two bank; five position switch body approx. 6-25/64" x 3 3/4" dia.; four tapped No. 6-32 mounting bushings; operated by Control "P".	Antenna Load Coil Switch	CBHT, 263-104	USAF 47D 47400
S2503	3Z9826-54 R16-USAF 47D47412	SWITCH: Four bank; two position; switch body approx. 9 1/2" x 3 3/4" dia. four tapped No. 6-32 mounting bushings; ceramic support post in rear; operated by control "O".	Antenna Switch	CBHT, 263-105	USAF 47D 47412

**TABLE OF REPLACEABLE PARTS**  
**DYNAMOTOR POWER UNIT TYPE DY-11/ART-13**  
**MODEL: AN/ART-13 RADIO TRANSMITTING EQUIPMENT MAJOR ASSEMBLY: CONTROL UNIT**

Reference Symbol	Army Stock Number Navy Stock Number British Ref. Number	NAME OF PART and DESCRIPTION	FUNCTION	MFR. and DESIG. or AWS TYPE	CONT. or GOVT. DWG. or SPEC. No.
2601-2699		DYNAMOTOR POWER UNIT: Power control unit including Russell dynamotor to furnish all voltages necessary for the operation of the Type T-47/ART-13 Transmitter		830, 4160-2	500 6627 00E
C2601	# (R) 16 C 11312-2	CAPACITOR: 0.1 mf $\pm 20\%$ 600 WV	Transient suppressor	1640; 3030	930 0007 00
C2602	# (R) 16 C 11567	CAPACITOR: 4.0 mf $\pm 20\%$ 50 WV	Supply voltage filter	1640; 3030	930 0005 00
C2603	# (R) 16 C 11712-310	CAPACITOR: 2.0 mf $\pm 20\%$ 600 WV	Spark Suppressor	911, KG-3020; 1640, A7649; 1881, 67X2	930 7824 00 or 930N78B-M
C2604	# (R) 16 C 11336-75	CAPACITOR: 3-0.1 mf $\pm 20\%$ 600 WV	C2604A, C2604B, C2604C	911; 4210; 4250	956 0002 00
C2604A	#	CAPACITOR: Section of C2604	RF bypass		
C2604B	#	CAPACITOR: Section of C2604	Low voltage filter		
C2604C	#	CAPACITOR: Section of C2604	RF bypass		
C2605	# (R) 16 C 11325-60	CAPACITOR: 0.1 mf $\pm 20\%$ 1500 WV	High voltage filter	3030; 1640	930 0003 00
C2611	#	CAPACITOR: See C2604	C2611A, C2611B, C2611C		
C2611A	#	CAPACITOR: Section of C2611	RF bypass		
C2611B	#	CAPACITOR: Section of C2611	RF bypass		
C2611C	#	CAPACITOR: Section of C2611	RF bypass		
C2612	# (R) 16 C 11312-5	CAPACITOR: 0.1 mf $\pm 20\%$ 600 WV	Supply voltage filter	1640; 3030	930 0011 00

## TABLE OF REPLACEABLE PARTS

## MODEL: AN/ART-13 RADIO TRANSMITTING EQUIPMENT MAJOR ASSEMBLY: CONTROL UNIT DYNAMOTOR POWER UNIT TYPE DY-11/ART-13

Reference Symbol	Army Stock Number Navy Stock Number British Ref. Number	NAME OF PART and DESCRIPTION	FUNCTION	MFR. and DESIG. or AWS TYPE	CONT. or GOVT. DWG. or SPEC. No.
C2613	# (R) 16 C 11443	CAPACITOR: 1.3 mf $\pm 20\%$ 50 WV	Supply voltage filter	3030; 1640	930 0004 00
C2614	# (R) 16 C 11312	CAPACITOR: 0.1 mf $\pm 10\%$ 600 WV	Low voltage filter	1640; 3030	930 0006 00
C2615	#	CAPACITOR: 4.0 mf $\pm 20\%$ 600 WV	Low voltage filter	911, KG-3040; 1640, A7650; 1881, 67X5	930 0001 00
C2616	# (R) 16 C 11836-75	CAPACITOR: 2.0 mf $\pm 20\%$ 1500 WV	High voltage filter	911; 1881, T-15020	930 0002 00
C2617	#	CAPACITOR: See C2614	High voltage filter		
E2602A	#	RECEPTACLE: Type 1605B fuse mtg block	For F2601	830, 1605B	571 1605 20 or 1605B
E2602B	#	RECEPTACLE: Type 1606B fuse cover	Cover for receptacle E2602A	830, 1606B	571 1606 20 or 1606B
F2601	# (R) 17 F 14245	FUSE: 250 v 1 amp cartridge fuse 1- $\frac{1}{4}$ x 9/32 inch	LV secondary	2920, 4AG	264 5010 00 or 264N501
J2601	# (R) 17 R 1977-10	RECEPTACLE: 10 terminal wall mtg	Dynamotor supply connector plug re- ceptacle	630, RFK-10-31SL	371 5119 00 or 371N511R
J2602	# (R) 17 R 1965-48	RECEPTACLE: 3 terminal connector wall mounting	Dynamotor input plug receptacle	630, GK-C3-32S	371 2010 00 or 371N201
K2601	# (R) 16 R 5685-115	RELAY: Single pole normally open contacts	Dynamotor input control	2050, G-31199	401 7900 00 or 401N79
K2602	# (R) 16 R 5685-125	RELAY: 1 pole normally open double break cir- cuit control	Primary power contactor	2050, G-32793	405 2202 00 or 405NE202
K2603	# (R) 17 C 9130	RELAY: 10 amp 28 v dc single circuit	Transmitter power overload	4234, PM10	260 4560 00 or 260N456

**TABLE OF REPLACEABLE PARTS**  
**DYNAMOTOR POWER UNIT TYPE DY-11/ART-13**  
**MODEL: AN/ART-13 RADIO TRANSMITTING EQUIPMENT MAJOR ASSEMBLY: CONTROL UNIT**

Reference Symbol	Army Stock Number Navy Stock Number British Ref. Number	NAME OF PART and DESCRIPTION	FUNCTION	MFR. and DESIG. or AWS TYPE	CONT. or GOVT. DWG. or SPEC. No.
K2604	# (R) 17 C 9160	RELAY: 40 amp 28 v dc single circuit	Dynamotor primary power overload	4234, PM40	260 4550 00 or 260N455
K2605	# (R) 16 R 5069-20	RELAY: 2 PDT circuit control	Power change	2050, G-33375	410 2000 00 or 410N20
K2606	# (R) 17 S 25171	RELAY: SPDT barometric circuit control switch	Voltage control	1884, CR2927	260 4570 00 or 260N457
L2601	# (R) 16 C 11325-60	CHOKE: 5.5 uh spiral wound low resistance	Supply voltage filter choke	1640	240 0003 00
L2602	# (R) 16 C 17184-15	CHOKE: Multi-section duo-lateral wound 1.0 mh, 0.3 amp 10 ohms	Low voltage filter choke	3220, R-300U; 3090	240 5800 00 or 240N58
L2603	#	CHOKE: See L2602	High voltage filter choke		
L2604	#	CHOKE: See L2602	High voltage filter choke		
L2605	# (R) 16 C 17183	CHOKE: 5.5 uh spiral wound low resistance	Supply voltage filter choke	1640	240 0002 00
L2606	# (R) 16 C 17184	CHOKE: 0.5 mh 0.75 amp 3 section duo-lateral	Low voltage filter choke	3090	240 0004 00
L2607	#	CHOKE: See L2606	Low voltage filter choke		
L2608	#	CHOKE: See L2602	High voltage filter choke		
L2609	#	CHOKE: See L2602	High voltage filter choke		
L2610	#	CHOKE: See L2602	High voltage filter choke		

## TABLE OF REPLACEABLE PARTS

MODEL: AN/ART-13 RADIO TRANSMITTING EQUIPMENT      DYNAMOTOR POWER UNIT TYPE DY-11/ART-13  
 MAJOR ASSEMBLY: CONTROL UNIT

Reference Symbol	Army Stock Number Navy Stock Number British Ref. Number	NAME OF PART and DESCRIPTION	FUNCTION	MFR. and DESIG. or AWS TYPE	CONT. or GOVT. DWG. or SPEC. No.
R2601	#	RESISTOR: 47 ohm $\pm 20\%$ 1 w	Spark suppressor	4230	729 7474 00 or 729NG47-M
R2602	#	RESISTOR: 20.1 ohm, tapped at 13.4 ohm $\pm 5\%$ 0.5 amp	Voltmeter multiplier	3450	717 4100 00 or 717ND1
R2604	# (R) 16R 17263-18-3	RESISTOR: 330 ohm $\pm 20\%$ 1 w	Spark suppressor	2360, BW1-Navy	708 3305 24 or 708N330NB-M

CONTRACT or ORDER No. NXsa-44558

PAGE 38 of 52 PAGES

**TABLE OF REPLACEABLE PARTS**

**MODEL: AN/ART-13 RADIO TRANSMITTING EQUIPMENT**      **MAJOR ASSEMBLY: DYNAMOTOR**

**DYNAMOTOR POWER UNIT TYPE DY-11/ART-13**

Reference Symbol	Army Stock Number Navy Stock Number British Ref. Number	NAME OF PART and DESCRIPTION	FUNCTION	MFR. and DESIG. or AWS TYPE	CONT. or GOVT. DWG. or SPEC. No.
D2601	#	DYNAMOTOR: Input: 27 v 32 amp dc Output number 1: 400 v 0.75 amp dc Output number 2: 750 v 0.35 amp dc	Dynamotor	3970, 502 D3 C0A	231 0003 00 or 231N47
C2606	# (R) 16 C 10401-15	CAPACITOR: .005 mf $\pm 20\%$ 1000 TV	Motor brush spark suppressor	911, 3WLS; 4030, JLS; 4210, MKBW	909 2506 40 or 909N250F-M
C2607	#	CAPACITOR: See C2606	Motor brush spark suppressor		
C2608	# (R) 16 C 10451	CAPACITOR: .006 mf $\pm 20\%$ 5000 TV	Low voltage filter	911, 9LS; 4030, A2LS	950 2601 14 or 950N260A1-M
C2609	#	CAPACITOR: See C2608	High voltage filter		
C2610	#	CAPACITOR: See C2608	High voltage filter		
C2613	#	CAPACITOR: See C2606	Motor brush spark suppressor		
C2619	#	CAPACITOR: See C2606	Motor brush spark suppressor		
E2601A	# (R) 16 B 12226-20	BRUSH: For dynamotor for 231 0003 00 or 231N47	+ Input brush	3970, 13836	234 1280 00 or 234N128
E2601B	# (R) 16 B 12226-25	BRUSH: For dynamotor for 231 0003 00 or 231N47	- Input brush	3970, 13836-A	234 1290 00 or 234N129
E2601C	# (R) 16 B 12226	BRUSH: For dynamotor for 231 0003 00 or 231N47	+ LV brush	3970, 13742	234 1260 00 or 234N126
E2601D	# (R) 16 B 12226-5	BRUSH: For dynamotor for 231 0003 00 or 231N47	- LV brush	3970, 13742-A	234 1270 00 or 234N127
E2601E	# (R) 16 B 12226-10	BRUSH: For dynamotor for 231 0003 00 or 231N47	+ HV brush	3970, 13741	234 1240 00 or 234N124

**TABLE OF REPLACEABLE PARTS**  
**DYNAMOTOR POWER UNIT TYPE DY-11/ART-13**  
**MODEL: AN/ART-13 RADIO TRANSMITTING EQUIPMENT**      **MAJOR ASSEMBLY: DYNAMOTOR**

Reference Symbol	Army Stock Number Navy Stock Number British Ref. Number	NAME OF PART and DESCRIPTION	FUNCTION	MFR. and DESIG. or AWS TYPE	CONT. or GOVT. DWG. or SPEC. No.
E2601F	# (R) 16 B 12226-15	BRUSH: For dynamotor for 231 0003 00 or 231N47	—HV brush	3970, 18741-A	234 1250 00 or 234N125
E2601G	#	BRUSH: See E2601A			
E2601H	#	BRUSH: See E2601B			

**CONTRACT or ORDER No. NXsa-44558**

**PAGE 40 of 52 PAGES**



**TABLE OF REPLACEABLE PARTS**  
**MODEL: AN/ART-13 RADIO TRANSMITTING EQUIPMENT**  
**MAJOR ASSEMBLY: LF OSCILLATOR TYPE O-17/ART-13A**

Reference Symbol	Army Stock Number Navy Stock Number British Ref. Number	NAME OF PART and DESCRIPTION	FUNCTION	MFR. and DESIG. or JAN TYPE	CONT. or GOVT. DWG. or SPEC. No.
2601*- 2699*		<b>LOW FREQUENCY OSCILLATOR:</b> Includes tube, Frequency range 200 kc to 600 kc. Interchangeable with dummy LFO Oscillator Type NX-128/ART-13			AF 47G47200
C2601*		CAPACITOR: MICA .002 mf $\pm 20\%$ 750 WV	LFO screen bypass	4030, BEW-15220-B20	
C2602*		CAPACITOR: MICA .000047 mf $\pm 20\%$ 500 WV	LFO cathode Coupling	JAN Type CM20B470M	JAN-C-5
C2603*		CAPACITOR: CERAMIC .0003 mf $\pm 20\%$ 500 WV	LFO feedback Coupling	JAN Type CC45HG301G	JAN-C-20A
C2604*		CAPACITOR: .0022 mf $\pm 1\%$	LFO feedback Coupling		AF47B47218
C2605*		CAPACITOR: MICA .01 mf $\pm 5\%$ 2500 WV	LFO cathode bypass	JAN Type CM60F103J	JAN-C-5
C2606*		CAPACITOR: MICA .002065 mf $\pm 1\%$	LFO grid Padding		AF 47B47216-1
C2607*		CAPACITOR: Total capacity with C2607B* .0043 mf $\pm 1\%$	LFO grid Padding		AF 47B47216-2
C2607B*		CAPACITOR: See C2607*	LFO grid Padding		
C2608A*		CAPACITOR: Variable; 55-240 mmf supplied with C2608B*, C2608C* & C2608D* as an assembly	LFO grid Padding	700, A82-010	
C2608B*		CAPACITOR: Same as C2608A*			
C2608C*		CAPACITOR: Same as C2608A*			

**TABLE OF REPLACEABLE PARTS**  
**MODEL: AN/ART-13 RADIO TRANSMITTING EQUIPMENT**      **MAJOR ASSEMBLY: LF OSCILLATOR TYPE O-17/ART-13A**

Reference Symbol	Army Stock Number Navy Stock Number British Ref. Number	NAME OF PART and DESCRIPTION	FUNCTION	MFR. and DESIG. or JAN TYPE	CONT. or GOVT. DWG. or SPEC. No.
C2608D*		CAPACITOR: Same as C2608A *	C2607A*, C2607B* trimmer		
E2608*		CYL. STANDOFF: $\frac{3}{8}$ x $\frac{1}{2}$	LFO lead standoff	JAN Type NS4W0104	JAN-I-8
L2601*		CHOKES: 5.4 mh multi-section	LFO feed choke		AF 47B47222
L2602*		INDUCTOR: 50 turns No. 26 wire	LFO grid tuning inductor		AF 47G47269
L2603*		CHOKES: 2.5 mh multi-section	LFO cathode choke	3220, R-100S	
P2601*		PLUG: 6 terminal connector chassis mtg.	LFO connector plug	2580, P-306-AB	
R2601*		RESISTOR: COMPOSITION 15000 ohms $\pm 10\%$ 1W	LFO grid	JAN Type RC31BF153K	JAN-R-11
S2601*		SWITCH: 3 position; 1 pole; 1 section stator assembly	LFO frequency range switch		AF 47D47267
V2601*		TUBE: Type 1625 beam pentode	LFO	JAN Type 1625	JAN-1A
X2601*		SOCKET: 7 terminal base Isolantite	For V2601*	2570, 227N-BC	

**CONTRACT NO. AF33 (038)-7303, Change Order No. 2.**

TABLE OF REPLACEABLE PARTS

DYNAMOTOR POWER UNIT TYPE DY- /ART-13

MODEL: AN/ART-13 RADIO TRANSMITTING EQUIPMENT      MAJOR ASSEMBLY: CONTROL UNIT

Reference Symbol	Army Stock Number Navy Stock Number British Ref. Number	NAME OF PART and DESCRIPTION	FUNCTION	MFR. and DESIG. or AWS TYPE	CONT. or GOVT. DWG. or SPEC. No.
2701-2799		DYNAMOTOR POWER UNIT: Power Control Unit including Fractional dynamotor to furnish all voltages necessary for the operation of the Type T-47/ART-13 Transmitter		830, 416U-2	500 6627 00E
C2701	# (R) 16 C 11312-2	CAPACITOR: 0.1 mf $\pm 20\%$ 600 WV	Transient suppressor	1640; 3030	930 0007 00
C2702	# (R) 16 C 11567	CAPACITOR: 4.0 mf $\pm 20\%$ 50 WV	Supply voltage filter	1640; 3030	930 0005 00
C2703	# (R) 16 C 11712-310	CAPACITOR: 2.0 mf $\pm 20\%$ 600 WV	Spark suppressor	911, KG-3020; 1640, A7649; 1881, 67X2	930 7824 00 or 930N78B-M
C2704	# (R) 16 C 11386-75	CAPACITOR: 3-0.1 mf $\pm 20\%$ 600 WV	C2704A, C2704B, C2704C	911; 4210; 4250	956 0002 00
C2704A	#	CAPACITOR: Section of C2704	RF bypass		
C2704B	#	CAPACITOR: Section of C2704	Low voltage filter		
C2704C	#	CAPACITOR: Section of C2704	RF bypass		
C2705	# (R) 16 C 11825-60	CAPACITOR: 0.1 mf $\pm 20\%$ 1500 WV	High voltage filter	3030; 1640	930 0003 00
C2711	#	CAPACITOR: See C2704	C2711A, C2711B, C2711C		
C2711A	#	CAPACITOR: Section of C2711	RF bypass		
C2711B	#	CAPACITOR: Section of C2711	RF bypass		
C2711C	#	CAPACITOR: Section of C2711	RF bypass		
C2712	# (R) 16 C 11312-5	CAPACITOR: 0.1 mf $\pm 20\%$ 600 WV	Supply voltage filter	1640; 3030	930 0011 00

**TABLE OF REPLACEABLE PARTS**  
**MODEL: AN/ART-13 RADIO TRANSMITTING EQUIPMENT**      **MAJOR ASSEMBLY: CONTROL UNIT**      **DYNAMOTOR POWER UNIT TYPE DY- /ART-13**

Reference Symbol	Army Stock Number Navy Stock Number British Ref. Number	NAME OF PART and DESCRIPTION	FUNCTION	MFR. and DESIG. or AWS TYPE	CONT. or GOVT. DWG. or SPEC. No.
C2713	# (R) 16 C 11443	CAPACITOR: 1.3 mf $\pm 20\%$ 50 WV	Supply voltage filter	3030; 1640	930 0004 00
C2714	# (R) 16 C 11312	CAPACITOR: 0.1 mf $\pm 10\%$ 600 WV	Low voltage filter	1640; 3030	930 0006 00
C2715	#	CAPACITOR: 4.0 mf $\pm 20\%$ 600 WV	Low voltage filter	911, KG-3040; 1640, A7650; 1881, 67X5	930 0001 00
C2716	# (R) 16 C 11239	CAPACITOR: 2.0 mf $\pm 20\%$ 1500 WV	High voltage filter	911; 1881, T-15020	930 0002 00
C2717	#	CAPACITOR: See C2714	High voltage filter		
E2702A	#	RECEPTACLE: Type 1605B fuse mtg block	For F2701	830, 1605B	571 1605 20 or 1605B
E2702B	#	RECEPTACLE: Type 1606B fuse cover	Cover for receptacle E2702A	830, 1606B	571 1606 20 or 1606B
F2701	# (R) 17 F 14245	FUSE: 250 v 1 amp cartridge fuse 1- $\frac{1}{4}$ x 9/32	LV secondary	2920, 4AG	264 5010 00 or 264N501
J2701	# (R) 17 R 1977-10	RECEPTACLE: 10 terminal wall mtg	Dynamotor supply connector plug receptacle	630, RFK-10-31SL	371 5119 00 or 371N511R
J2702	# (R) 17 R 1965-48	RECEPTACLE: 3 term connector wall mounting	Dynamotor input plug receptacle	630, GK-C3-32S	371 2010 00 or 371N201
K2701	# (R) 16 R 5685-115	RELAY: Single pole normally open contacts	Dynamotor input control	2050, G-31199	401 7900 00 or 401N79
K2702	# (R) 16 R 5685-125	RELAY: 1 pole normally open double break circuit control	Primary power contactor	2050, G-32793	405 2202 00 or 405NB202
K2703	# (R) 17 C 9130	RELAY: 10 amp 28 v dc single circuit	Transmitter power overload	4234, PM10	260 4560 00 or 260N456

**TABLE OF REPLACEABLE PARTS**  
**MODEL: AN/ART-13 RADIO TRANSMITTING EQUIPMENT**      **MAJOR ASSEMBLY: CONTROL UNIT**      **DYNAMOTOR POWER UNIT TYPE DY- /ART-13**

Reference Symbol	Army Stock Number Navy Stock Number British Ref. Number	NAME OF PART and DESCRIPTION	FUNCTION	MFR. and DESIG. or AWS TYPE	CONT. or GOVT. DWG. or SPEC. No.
K2704	# (R) 17 C 9160	RELAY: 40 amp 28 v dc single circuit	Dynamotor primary power overload	4234, PM40	260 4550 00 or 260N455
K2705	# (R) 16 R 5069-20	RELAY: 2 PDT circuit control	Power change	2050, G-33375	410 2000 00 or 410N20
K2706	# (R) 17 S 25171	RELAY: SPDT barometric circuit control switch	Voltage control	1884, CR2927	260 4570 00 or 260N457
L2701	# (R) 16 C 17183-5	CHOKE: 5.5 uh spiral wound low resistance	Supply voltage filter choke	1640	240 0003 00
L2702	# (R) 16 C 17184-15	CHOKE: Multi-section duo-lateral wound 1.0 mh, 0.3 amp 10 ohms	Low voltage filter choke	3220, R-300U; 3090	240 5800 00 or 240N58
L2703	#	CHOKE: See L2702	High voltage filter choke		
L2704	#	CHOKE: See L2702	High voltage filter choke		
L2705	# (R) 16 C 17183	CHOKE: 5.5 uh spiral wound low resistance	Supply voltage filter choke	1640	240 0002 00
L2706	# (R) 16 C 17184	CHOKE: 0.5 mh 0.75 amp 3 section duo-lateral	Low voltage filter choke	3090	240 0004 00
L2707	#	CHOKE: See L2706	Low voltage filter choke		
L2708	#	CHOKE: See L2702	High voltage filter choke		
L2709	#	CHOKE: See L2702	High voltage filter choke		
L2710	#	CHOKE: See L2702	High voltage filter choke		

CONTRACT or ORDER No. NXsa-44558

PAGE 43 of 52 PAGES

**TABLE OF REPLACEABLE PARTS**  
**MODEL: AN/ART-13 RADIO TRANSMITTING EQUIPMENT**      **MAJOR ASSEMBLY: CONTROL UNIT**      **DYNAMOTOR POWER UNIT TYPE DY- /ART-13**

Reference Symbol	Army Stock Number Navy Stock Number British Ref. Number	NAME OF PART and DESCRIPTION	FUNCTION	MFR. and DESIG. or AWS TYPE	CONT. or GOVT. DWG. or SPEC. No.
R2701	#	RESISTOR: 47 ohm $\pm 20\%$ 1 w	Spark suppressor	4230	729 7474 00 or 729NG47-M
R2702	#	RESISTOR: 20.1 ohm, tapped at 13.4 ohm $\pm 5\%$ 0.5 amp	Voltmeter multiplier	3450	717 4100 00 or 717ND1
R2704	# (R) 16 R 17263-18-3	RESISTOR: 330 ohm $\pm 20\%$ 1 w	Spark suppressor	2360, BW1-Navy	708 3305 24 or 708N330NB-M

**CONTRACT or ORDER No. NXsa-44558**

**PAGE 44 of 52 PAGES**

**TABLE OF REPLACEABLE PARTS**  
**DYNAMOTOR POWER UNIT TYPE DY- /ART-13**  
**MODEL: AN/ART-13 RADIO TRANSMITTING EQUIPMENT MAJOR ASSEMBLY: DYNAMOTOR**

Reference Symbol	Army Stock Number Navy Stock Number British Ref. Number	NAME OF PART and DESCRIPTION	FUNCTION	MFR. and DESIG. or AWS TYPE	CONT. or GOVT. DWG. or SPEC. No.
D2701	#	DYNAMOTOR: Input: 27 v 32 amp dc Output number 1: 400 v 0.75 amp dc Output number 2: 750 v 0.35 amp dc	Dynamotor	1740, D-100	231 0008 00
C2706	# (R) 16 C 10401-15	CAPACITOR: .005 mf $\pm 20\%$ 1000 TV	Motor brush spark suppressor	911, 3WLS; 4080, JLS; 4210, MKBW	909 2506 40 or 909N250F-M
C2707	#	CAPACITOR: See C2706	Motor brush spark suppressor		
C2708	# (R) 16 C 10451	CAPACITOR: .006 mf $\pm 20\%$ 5000 TV	Low voltage filter	911, 9LS; 4080, A2LS	950 2601 14 or 950N260A1-M
C2709	#	CAPACITOR: See C2708	High voltage filter		
C2710	#	CAPACITOR: See C2708	High voltage filter		
E2701A	#	BRUSH: For dynamotor for 231 0008 00	+Input brush		
E2701B	#	BRUSH: For dynamotor for 231 0008 00	-Input brush		
E2701C	#	BRUSH: For dynamotor for 231 0008 00	+LV brush		
E2701D	#	BRUSH: For dynamotor for 231 0008 00	-LV brush		
E2701E	#	BRUSH: For dynamotor for 231 0008 00	+HV brush		
E2701F	#	BRUSH: For dynamotor for 231 0008 00	-HV brush		

**TABLE OF REPLACEABLE PARTS**

**MODEL: AN/ART-13 RADIO TRANSMITTING EQUIPMENT**

**MAJOR ASSEMBLY: ALTERNATE AUTOTUNE MOTORS**

**RADIO TRANSMITTER TYPE T-47/ART-13**

Reference Symbol	Army Stock Number Navy Stock Number British Ref. Number	NAME OF PART and DESCRIPTION	FUNCTION	MFR. and DESIG. or AWS TYPE	CONT. or GOVT. DWG. or SPEC. No.
B2801	#	MOTOR: 1/20 hp 28 v dc nominal 20 v min 32 v max	Autotune motor	1390, NY-818C-A	508 0818 31 or 818C-A
C2801	# (R) 16 C 10351-26	CAPACITOR: .004 mf $\pm 20\%$ 600 TV	Motor B2801 spark suppressor	4030, JS; 911, 3WS	909 2406 40 or 909N240F-M
C2802	#	CAPACITOR: See C2801	Motor B2801 spark suppressor		
E2801A	# (R) 16 B 12226-30	BRUSH: + & — brush	For Autotune motor B2801	1390	234 1300 00 or 234N130
E2801B	#	BRUSH: See E2801A	For Autotune motor B2801		
B2901	#	MOTOR: 1/20 hp 28 v dc nominal 20 v min 32 v max	Autotune motor	3440, NY-818C-B	508 0818 32 or 818C-B
C2901	#	CAPACITOR: .0035 mf $\pm 20\%$ 600 TV	Motor B2901 spark suppressor	911, 1WLS; 4030, CLS; 4210, MWBW	909 0003 00
C2902	#	CAPACITOR: See C2901	Motor B2901 spark suppressor		
E2901A	# (R) 16 B 12320-40	BRUSH: + & — brush	For Autotune motor B2901	3440; 4324	234 1301 00 or 234N130A
E2901B	#	BRUSH: See E2901A	For Autotune motor B2901		
E2901C	#	BRUSH: See E2901A	For Autotune motor B2901		
E2901D	#	BRUSH: See E2901A	For Autotune motor B2901		



TABLE OF REPLACEABLE PARTS  
 MODEL: AN/ART-13 RADIO TRANSMITTING EQUIPMENT

Reference Symbol	Army Stock Number Navy Stock Number British Ref. Number	NAME OF PART and DESCRIPTION	FUNCTION	MFR. and DESIG. or AWS TYPE	CONT. or GOVT. DWG. or SPEC. No.
		<b>COMPLETE UNIT ASSEMBLIES</b>			
		ASSEMBLY: MCW-CFI unit		830, 8Q-2	500 4587 005
		ASSEMBLY: Audio unit		830, 26S-1	500 7620 005
		ASSEMBLY: Multiplier unit		830, 318E-1	500 3149 004
		ASSEMBLY: HFO unit*		830, 33X-1	500 4473 005
		ASSEMBLY: Singleturn Autotune unit "D" (Includes wick lubricator assembly)		830, 96J-1	571 0737 30 or GA-K737C
		ASSEMBLY: Singleturn Autotune unit "C" (Includes wick lubricator assembly)		830, 96J-2	572 0737 30 or GB-K737C
		ASSEMBLY: Singleturn Autotune unit "E" (Includes wick lubricator assembly)		830, 96J-3	573 0737 30 or GC-K737C
		ASSEMBLY: Singleturn Autotune unit "A" (Includes wick lubricator assembly)		830, 96J-4	571 0738 30 or GA-K738C
		<b>MISCELLANEOUS</b>			
	#	MANUAL: Operating (calibration book)		830	520 9077 00
	(R) 17 F 1532-8	FERRULE: Conduit		200	019 2034 00 or 19N204X8
	(R) 17 N 995	COUPLING: Conduit		630	019 2050 00 or 19N205X8
	(R) 17 C 2075	CAP: Protective		630, RWK-59A1	371 1069 00 or 371N106R
	(R) 16 D 2302-35	KNOB: HFO dial		830	507 5524 00 or X-5524
	(R) 16 D 2380	DIAL: HFO counter		830	507 5527 00 or X-5527

CONTRACT or ORDER No. NXsq-44558

PAGE 47 of 52 PAGES

## TABLE OF REPLACEABLE PARTS

## MODEL: AN/ART-13 RADIO TRANSMITTING EQUIPMENT

Reference Symbol	Army Stock Number Navy Stock Number British Ref. Number	NAME OF PART and DESCRIPTION	FUNCTION	MFR. and DESIG. or AWS TYPE	CONT. or GOVT. DWG. or SPEC. No.
		<b>MISCELLANEOUS (CONTINUED)</b>			
	(R) 16 K 3322	KNOB: Dial lock and fiducial		830	507 5531 00 or X-5531
	(R) 16 D 2372	KNOB: Variometer dial		830	507 5586 00 or X-5586
	(R) 16 S CR NX5719	SLUG: HFO tuning		830	507 5719 00 or X-5719
	(R) 16 D 2302-60	KNOB: Capacitor dial		830	507 5796 00 or X-5796
	(R) 16 S CR NX6192	SLUG: Multiplier tuning		830	507 6192 00 or X-6192
	(R) 16 K 3356	KNOB: Bar		830	571 1765 20 or GA-1765B
		KNOB: Multiplier dial		830	508 1069 20 or Y-1069B
		KNOB: Network switch dial		830	508 1072 20 or Y-1072B
	(R) 43 S 436420	SCREW: 6-40 x 1/8 set	Alternate	500	328 0019 00 or 328N2EXTTP 328 0002 00
	(R) 43 S 436400	SCREW: 4-48 x 1/8 set	Alternate	500	328 0001 00 or 328 0005 00
	(R) 43 S 436430	SCREW: 8-36 x 1/8 set	Alternate	500	328 0020 00 or 328N2FVTP 328 0003 00
	(R) 43 S 436434	SCREW: 8-36 x 1/4 set	Alternate	500	328 0022 00 or 328N4FVTP 328 0004 00

## TABLE OF REPLACEABLE PARTS

## MODEL: AN/ART-13 RADIO TRANSMITTING EQUIPMENT

Reference Symbol	Army Stock Number Navy Stock Number British Ref. Number	NAME OF PART and DESCRIPTION	FUNCTION	MFR. and DESIG. or AWS TYPE	CONT. or GOVT. DWG. or SPEC. No.
		<b>MISCELLANEOUS (CONTINUED)</b>			
		SCREW: 4-40 x 1/2 long		3580	343 0137 00 or 343N8CXTP
		SPACER: 3/4 x 3/8 switch		830	500 0019 00A
		SPACER: 3/4 x 3/8 switch		830	500 0020 00A
		SPACER: 3/4 x 3/8 switch		830	500 0021 00A
		SCREW: Special		830	507 5762 00
		SCREW: Special		830	500 2704 001
		SCREW: 8-32 x 2-3/8 special		3580	330 4210 00
		SCREW: 8-32 x 2 1/2 special			344 0105 00
		COUPLER: 1/2 inch spline		830	500 2729 001
		COUPLER: 1-1/32 inch spline		830	500 2730 001
		GROMMET: 1-1/16 inch neoprene		880, 4757	201 1250 00
		GROMMET: 3/8 inch neoprene		2850, 905	201 1066
		GROMMET: 9/16 inch neoprene		2850, 913	201 1090 00
		GROMMET: 1/4 inch neoprene		2850, 901	201 1040 00
		CLIP: Grid		3220, 12	301 1001 00
		CLIP: Grid		3220, 24	301 6000 00
		KNOB: SIDETONE		830	507 5866 00
	(R) 16 W CR NX-5733	WRENCH: External spanner		830	507 5733 00 or X-5733

TABLE OF REPLACEABLE PARTS

MODEL: AN/ART-13 RADIO TRANSMITTING EQUIPMENT

Reference Symbol	Army Stock Number Navy Stock Number British Ref. Number	NAME OF PART and DESCRIPTION	FUNCTION	MFR. and DESIG. or AWS TYPE	CONT. or GOVT. DWG. or SPEC. No.
	(R) 16 W CR NX-5734	<b>MISCELLANEOUS (CONTINUED)</b> WRENCH: Internal spanner		830	507 5734 00 or X-5734
		WRENCH: Number 10 Bristo			024 9710 00 or 24N971
		WRENCH: Number 8 Bristo			024 0019 00 or 24N972
		WRENCH: Number 6 Bristo			024 9730 00 or 24N973
		WRENCH: Number 4 Bristo			024 2900 00 or 24N29
		SCREW DRIVER: Number 1 Phillips			024 3000 00 or 24N30
		SCREW DRIVER: Number 2 Phillips			024 3100 00 or 24N31
		SCREW DRIVER: .070 inch shank jewelers		4296, 555C	024 0015 00
		CAP: Input voltage brush holder (Wincharger Dynamotor)		4960, A-6588	234 0056 00
		CAP: Medium voltage brush holder (Wincharger Dynamotor)		4960, A-5065	234 4090 00
		CAP: High voltage brush holder (Wincharger Dynamotor)		4960, A-5125	234 0057 00
	#	CAP: Input voltage brush holder (Russell Dynamotor)		3970, 13092	
	#	CAP: Medium voltage brush holder (Russell Dynamotor)		3970, 12813	

MODEL: AN/ART-13 RADIO TRANSMITTING EQUIPMENT  
 TABLE OF REPLACEABLE PARTS

Reference Symbol	Army Stock Number Navy Stock Number British Ref. Number	NAME OF PART and DESCRIPTION	FUNCTION	MFR. and DESIG. or AWS TYPE	CONT. or GOVT. DWG. or SPEC. No.
		<b>MISCELLANEOUS (CONTINUED)</b>			
#		CAP: High voltage brush holder (Russell Dynamotor)		3970, 12813	
#		CAP: Input voltage brush holder (Fractional Dynamotor)		1740, BHC-102	
#		CAP: Medium voltage brush holder (Fractional Dynamotor)		1740, BHC-103	
#		CAP: High voltage brush holder (Fractional Dynamotor)		1740, BHC-103	
#		CAP: Brush holder (Emerson Autotune Motor)		1390, 96254-A	234 0058 00
		CAP: Brush holder (Ohio Autotune Motor)		3440, D-3689	234 0059 00
		CAP: Brush holder (Fractional Autotune Motor)		740, F-825	234 0060 00
		GAUGE: Feeler .005 inch		830	500 9135 001
		BASE: Shock mounting		3924, C-324	500 4594 005
		PLATE: Shock mounting (Grille)		3924	500 9356 003

AN 08-30ART13-5

TABLE OF REPLACEABLE PARTS

## MODEL: AN/ART-13 RADIO TRANSMITTING EQUIPMENT

Reference Symbol	Army Stock Number Navy Stock Number British Ref. Number	NAME OF PART and DESCRIPTION	FUNCTION	MFR. and DESIG. - or AWS TYPE	CONT. or GOVT. DWG. or SPEC. No.
	(R) 16 C CR 1149A	<b>MISCELLANEOUS AUTOTUNE PARTS</b>			
		CRANK: Autotune		830	571 1149 10 or GA-1149A
		SHAFT: Main line		830, NX-5512	507 5512 00 or NX-5512
		WORM: Small		830, NX-5513	500 6679 001 or NX-5513
		WORM: Large		830, NX-5519	507 5519 00 or NX-5519
		BEARING: Line shaft		830, NX-5724	507 5724 00 or NX-5724
		ARM: Positioning switch drive		830, 881A	571 0881 10 or 881A
		CHAIN: Autotune drive (Includes wick lubricator assembly)		830, NX-5603	507 5603 00 or NX-5603
		SPROCKET: Motor		830, NX-5602	507 5602 00 or NX-5602
		SPROCKET: Line shaft		830, NX-5514	507 5514 00 or NX-5514
	#	WICK LUBRICATOR: Autotune singleturn unit		830	500 4630 001
	#	WICK LUBRICATOR: Autotune multiturn unit		830	500 4644 001
	#	WICK LUBRICATOR: Autotune chain drive		830	500 4635 001

# Indicates that these parts are not contained in the bulk spares.

The High Frequency Oscillator Unit assembly includes the 96K-f Multiturn Autotune Unit "B" (Multiturn Unit includes Wick Lubricator Assembly)  
Standard vacuum tubes are supplied by various well known manufacturers.

CONTRACT or ORDER No. NXsa-44558

2. LIST OF MANUFACTURERS.

- 30 Aerovox Corporation  
742 Belleville Ave.  
New Bedford, Mass.
- 70 Alladin Radio Industries, Inc.  
223 W. Jackson Blvd.  
Chicago, Illinois
- 90 Allen-Bradley Company  
136 W. Greenfield Ave.  
Milwaukee, 4, Wisconsin
- 200 American Phenolic Corp.  
1830 S. 54th Ave.  
Chicago, 50, Cicero P.O. Ill.
- 360 Belden Mfr. Company  
P.O. Box 5070A  
Chicago, 80, Illinois
- 500 Bristol Company  
66 Bride Street  
Waterbury, 91, Connecticut
- 630 Cannon Electric Devel. Co.  
3209 Humboldt Street  
Los Angeles, 31, California
- 700 Centralab, Inc.  
900 E. Keefe Ave.  
Milwaukee, 1, Wisconsin
- 780 Chicago Transformer Corp.  
3501 Addison Street  
Chicago, 18, Illinois
- 810 Cinch Manufacturing Corp.  
2335-2347 W. Van Buren St.  
Chicago, 12, Illinois
- 830 Collins Radio Company  
855 35th Street N.E.  
Cedar Rapids, Iowa
- 880 Continental Rubber Works  
Erie, Pennsylvania
- 911 Cornell-Dubilier Corp.  
333 Hamilton Blvd.  
South Plainfield, 6, New Jersey
- 950 Coto-Coil Company, Inc.  
65 Pavilion Ave.  
Providence, 5, Rhode Island
- 1010 Cutler-Hammer, Inc.  
315 N. 12th Street  
Milwaukee, Wisconsin
- 1000 Drake Manufacturing Co.  
1713 West Hubbard Street  
Chicago, Illinois
- 1320 Hugh H. Eby, Inc.  
18 W. Chelton Avenue  
Philadelphia, 44, Pennsylvania
- 1390 Emerson Electric Mfg. Company, Inc.  
1824 Washington Avenue  
St. Louis, 3, Missouri
- 1640 John E. Fast & Company  
3123 N. Pulaski Road  
Chicago, 41, Illinois
- 1740 Fractional Motors Co.  
1501 N. Halsted Street  
Chicago, 22, Illinois
- 1820 G. M. Lab., Inc.  
4326 N. Knox Avenue  
Chicago, 41, Illinois
- 1860 General Cement Mfg. Company  
Rockford, Illinois
- 1888 General Electric Company  
Electronics Dept.  
754 State Street  
Schenectady, 7, New York
- CCG Grimes Manufacturing Co.  
Urbana, Ohio
- 2050 Guardian Elec. Mfg. Co.  
1400 West Washington Blvd.  
Chicago, 7, Illinois
- 2140 Hammarlund Mfg. Co., Inc.  
460 West 34th Street  
New York, 1, New York
- 2160 Arrow-Hart & Hegeman Co.  
103 Hawthorne Street  
Hartford, Connecticut
- 2360 International Resistance Co.  
401 N. Broad Street  
Philadelphia, 8, Pennsylvania
- Islip Islip Transformer & Metal, Inc.  
Beech Street  
Islip, L.I., New York
- 2410 Isolantite, Inc.  
Belleville, New Jersey
- 2570 E. F. Johnson Company  
Waseca, Minnesota
- 2580 Howard B. Jones Co.  
2460 W. George Street  
Chicago, 18, Illinois
- 2850 Lavelle Rubber Company  
424 North Wood Street  
Chicago, Illinois
- 2920 Littelfuse, Incorporated  
4757 Ravenswood Ave.  
Chicago, 40, Illinois

- |      |  |      |  |
|------|--|------|--|
| 2927 | Loftus Advertising Co.<br>P.O. Box 463<br>Cedar Rapids, Iowa                           | 4210 | Solar Manufacturing Corp.<br>285 Madison Avenue<br>New York, 17, New York      |
| 3030 | P. R. Mallory and Co., Inc.<br>3029 East Washington Street<br>Indianapolis, 6, Indiana | 4230 | Speer Resistor Corp.<br>St. Mary's, Pennsylvania                               |
| 3090 | Meissner Mfg. Company<br>Mt. Carmel, Illinois  | 4234 | Spencer Thermistat Co.<br>34 Forrest Street<br>Attleboro, Massachusetts        |
|      | CBHT Munston Manufacturing & Service, Inc.<br>Beech Street<br>Islip, L.I., N.Y.        | 4240 | Sperti, Inc.<br>Beech & Kenilworth Ave.<br>Norwood Station<br>Cincinnati, Ohio |
| 3220 | National Company, Inc.<br>61 Sherman Street<br>Malden, 48, Mass.                       | 4250 | Sprague Electric Co.<br>North Adams, Mass.                                     |
| 3240 | National Fabricated Products Co.<br>2650 W. Belden Avenue<br>Chicago, 47, Illinois     | 4296 | The L. S. Starret Mfg. Co.<br>101 Crescent Street<br>Athol, Massachusetts      |
| 3307 | National Tile Co.<br>Steatite Division<br>Anderson, Indiana                            | 4310 | Struthers Dunn, Inc.<br>1321 Arch Street<br>Philadelphia, 7, Pa.               |
| 3410 | Oak Manufacturing Co.<br>1260 Clybourne Avenue<br>Chicago, 10, Illinois                | 4324 | Superior Carbon Prod. Co.<br>9115 George Street<br>Cleveland, Ohio             |
| 3440 | Ohio Electric Mfg. Co.<br>5900 Maurice Avenue<br>Cleveland, 4, Ohio                    | 4335 | S-W Inductor Company<br>1056-58 N. Wood Street<br>Chicago, Illinois            |
| 3450 | Ohmite Mfg. Co.<br>4835 W. Flournoy Street<br>Chicago, 44, Illinois                    | CTE  | Telephonics Corporation<br>Huntington, New York                                |
| 3580 | Pheoll Mfg. Company<br>5700 Roosevelt Road<br>Chicago, 50, Illinois                    | 4707 | Vaco Products Company<br>317 E. Ontario<br>Chicago, Illinois                   |
|      | Plasteck Plasteck Incorporated<br>Byram, Conn.   | 4860 | Wells-Gardner & Company<br>2701 N. Kildaire Ave.<br>Chicago, 39, Illinois      |
| 3970 | Russell Electric Co.<br>340 W. Huron Street<br>Chicago, 10, Illinois                   | 4871 | Western Electric Company<br>195 Broadway<br>New York 7, New York               |
| 4030 | Sangamo Electric Co.<br>1935 Funk Street<br>Springfield, Illinois                      | 4900 | Westinghouse Electric Mfg. Co.<br>East Pittsburgh, Pennsylvania                |
| 4170 | F. W. Sickles Company<br>Box 920<br>Springfield, 2, Mass.                              | 4960 | Wincharger Corporation<br>East 7th at Division St.<br>Sioux City, 6, Iowa      |
|      |  | 4975 | Wirt Company<br>5221-27 Green Street<br>Germantown, Philadelphia, 44, Penn.    |



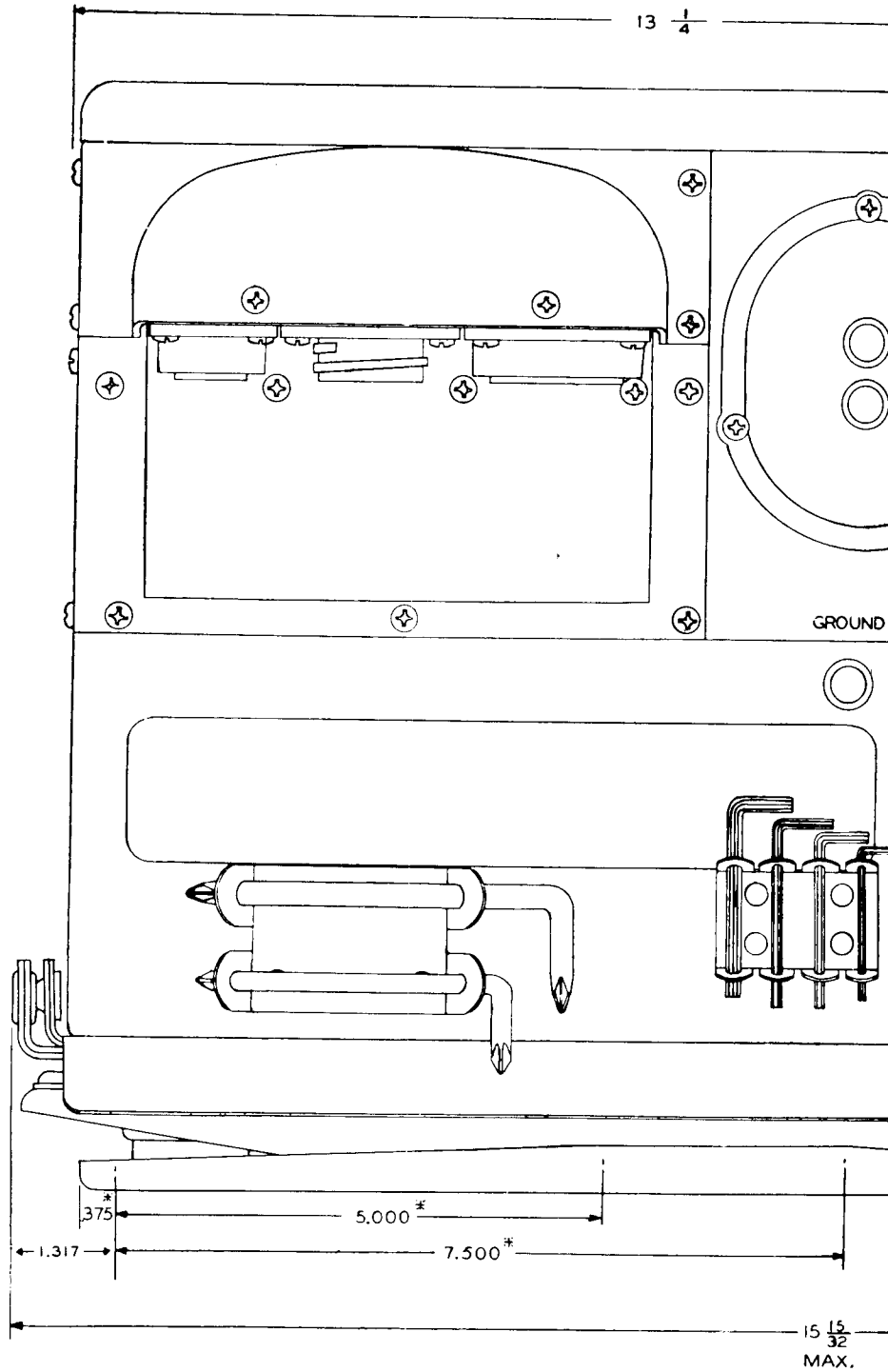

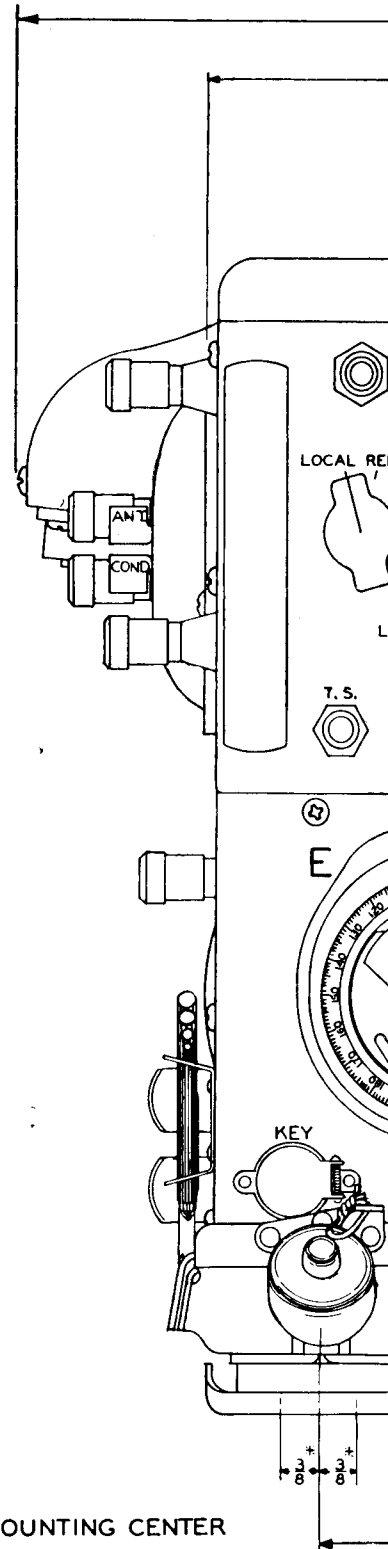
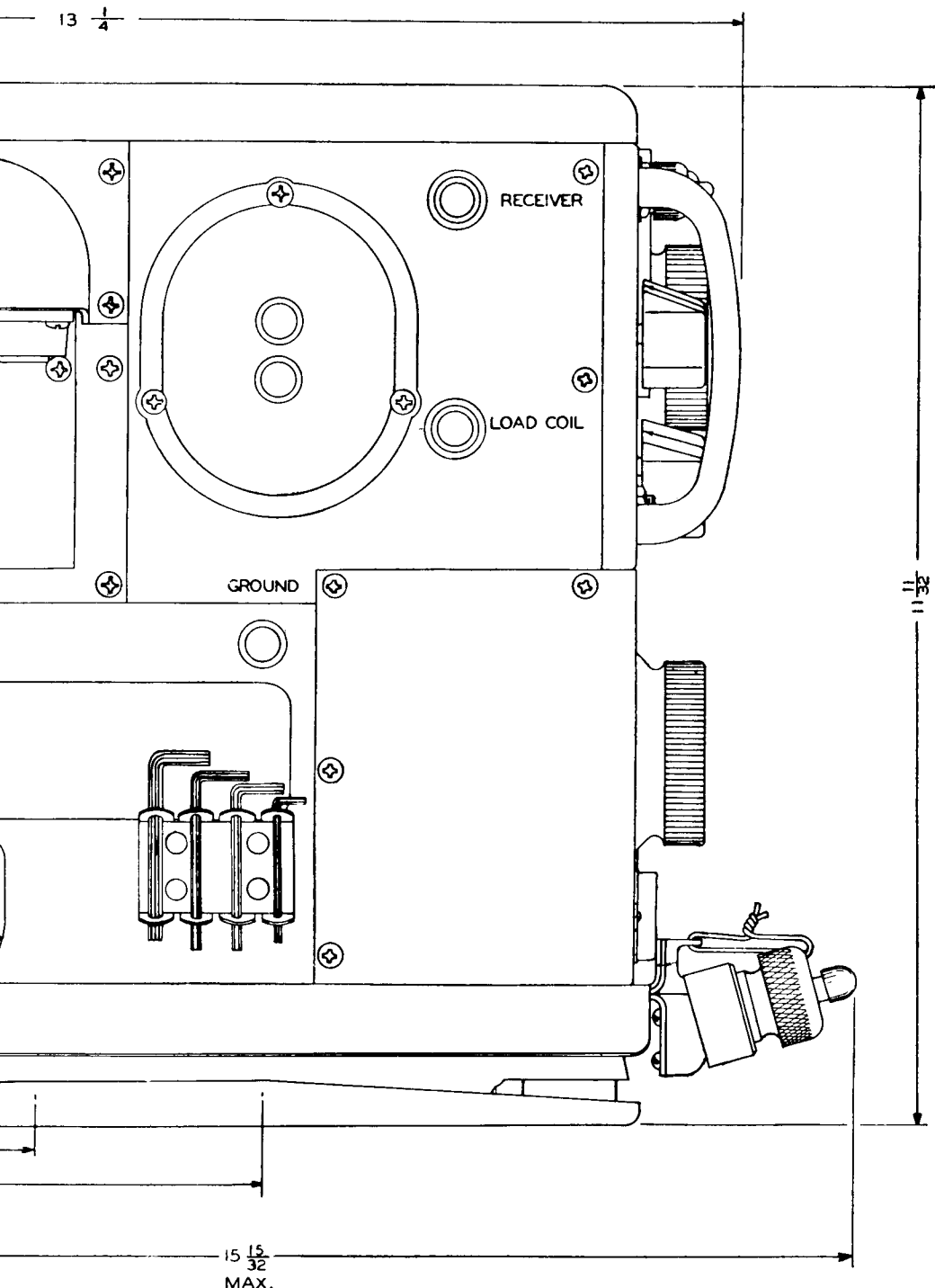

23  $\frac{9}{16}$

21  $\frac{11}{16}$

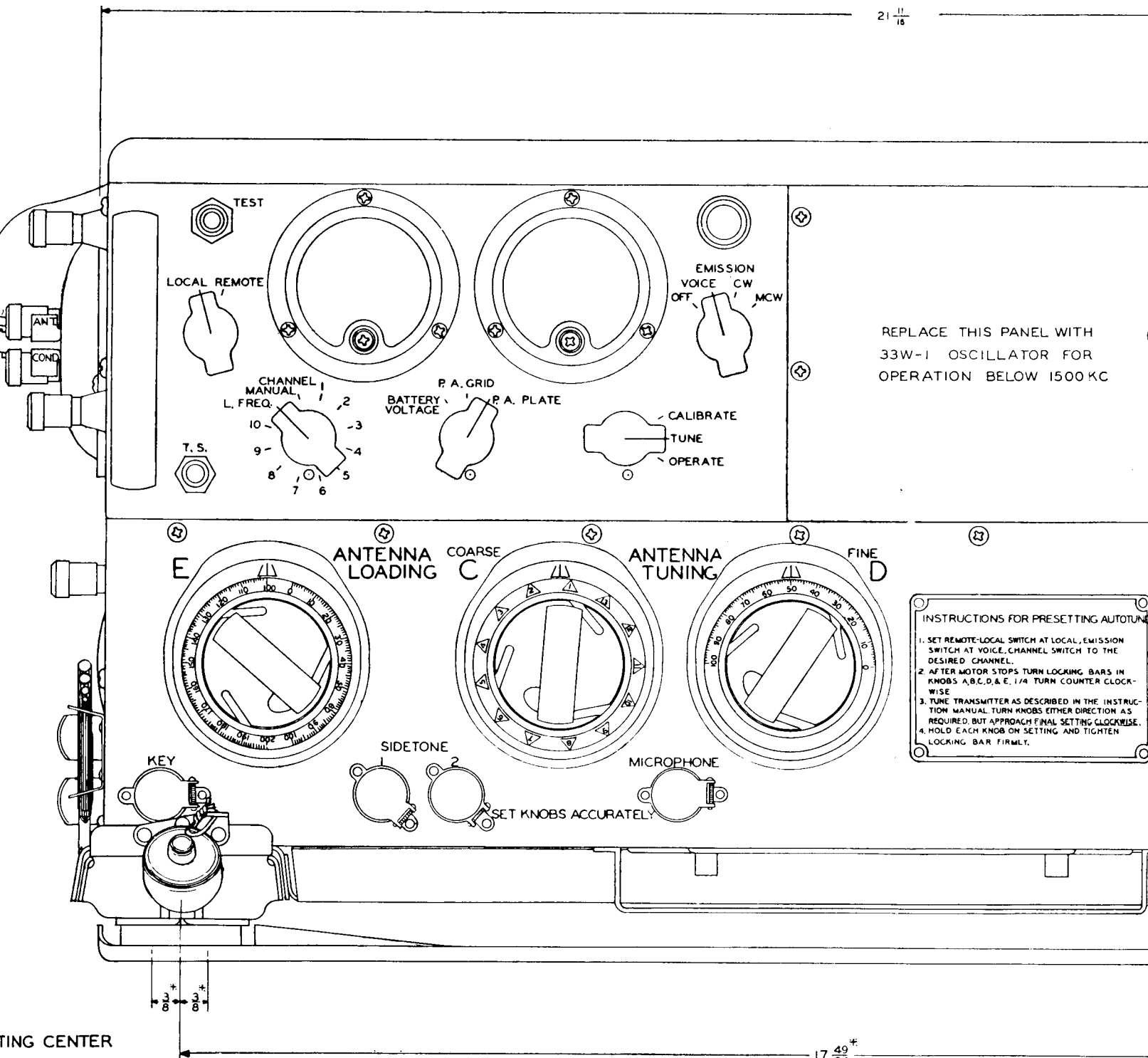

TING CENTER

17  $\frac{49}{64}$  ±.010

WEIGHT OF UNIT — 67 Lbs. ± 2%

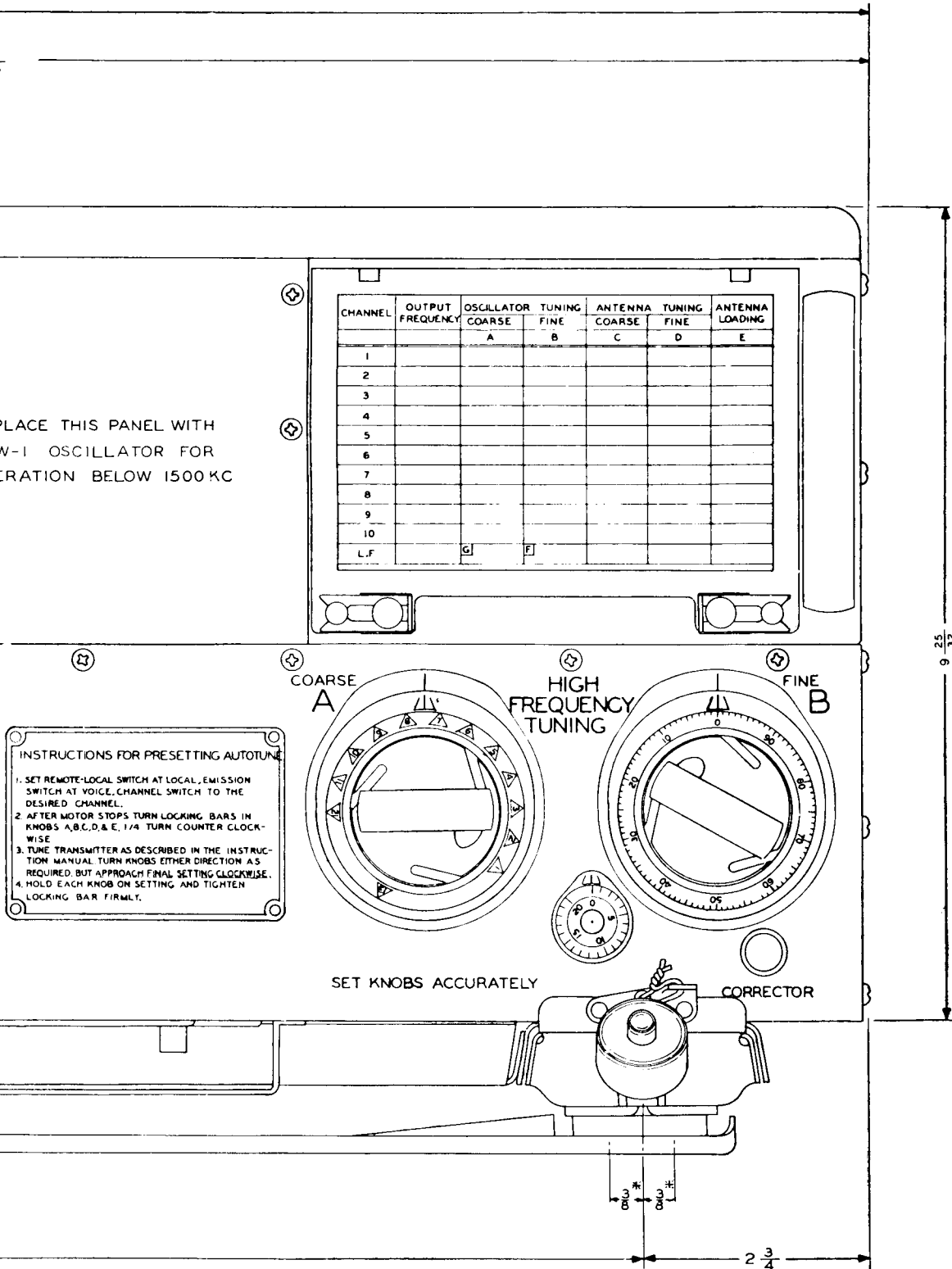
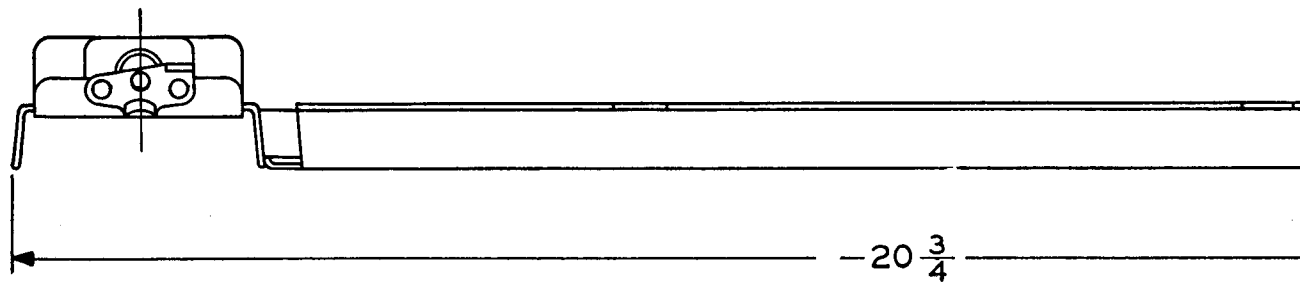
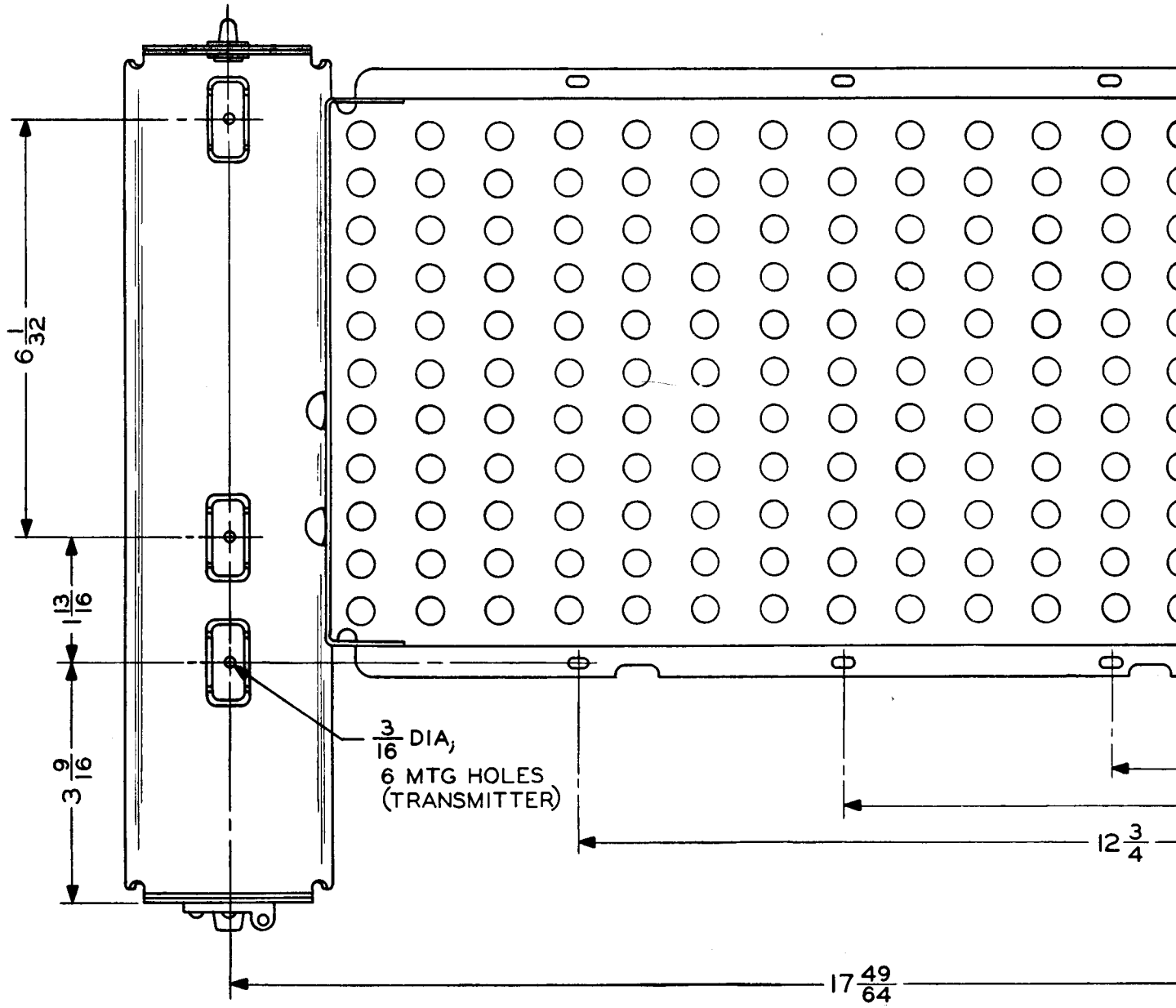

Figure 8-1. Type T-47/ART-13 Transmitter Installation Diagram

AN 08-30ART13-5



AN 08-30ART13-5

Sec. VIII  
AN 08-30ART13-5

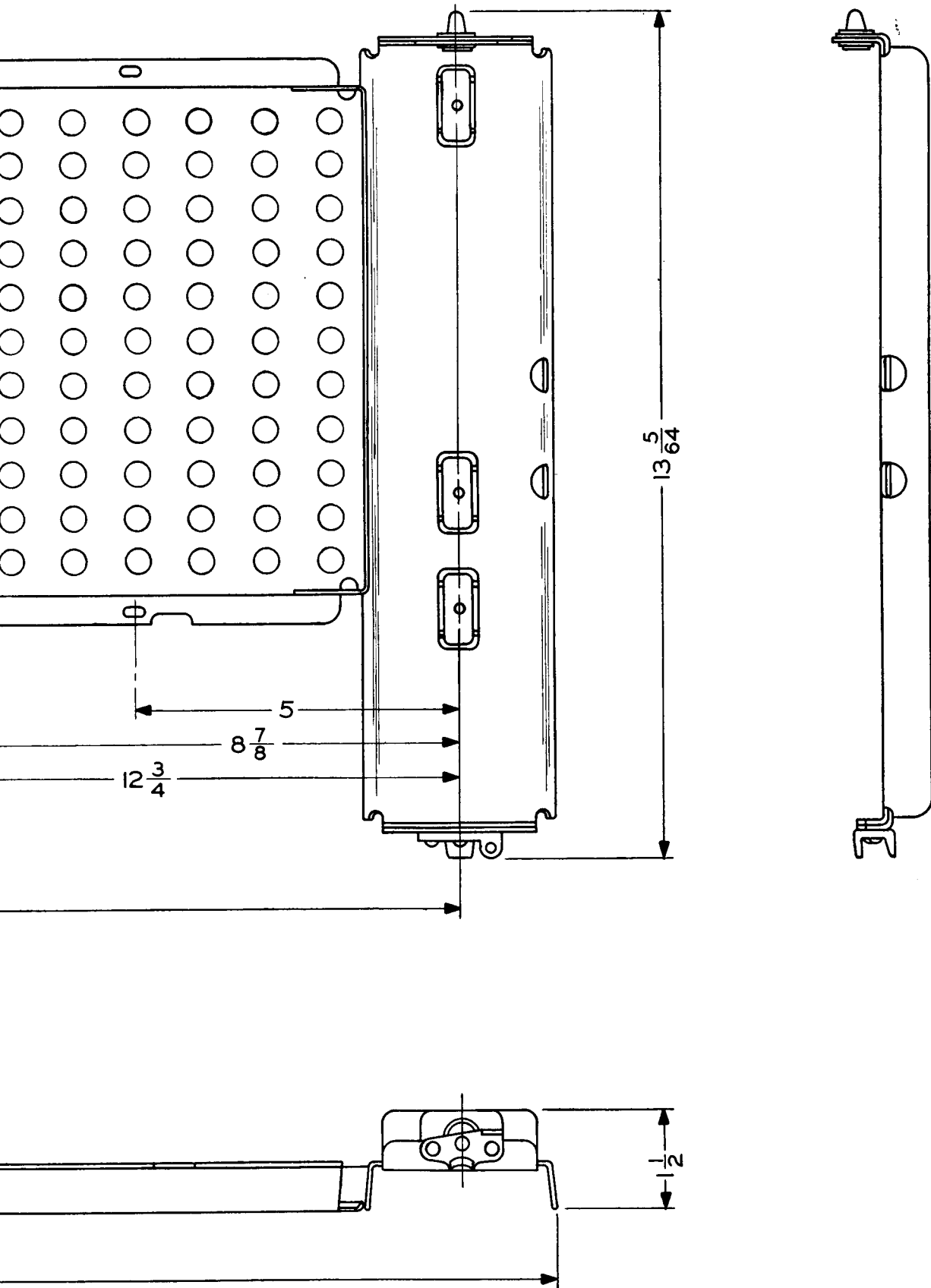
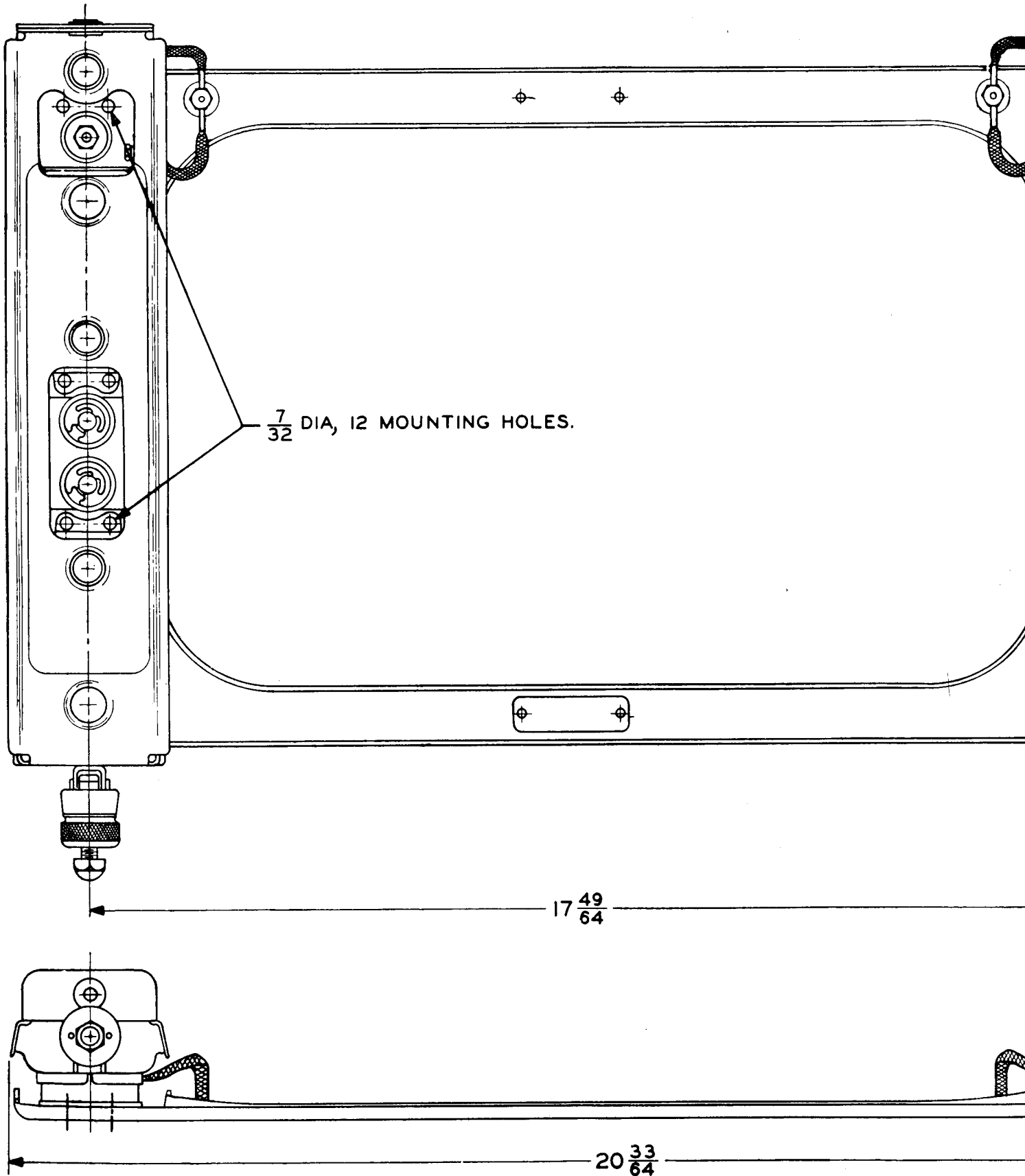

Figure 8-2. Type MT-283/ART-13  
Transmitter Mounting Plate

AN 08-30ART13-5



AN 08-30ART13-5

Sec. VIII  
AN 08-30ART13-5

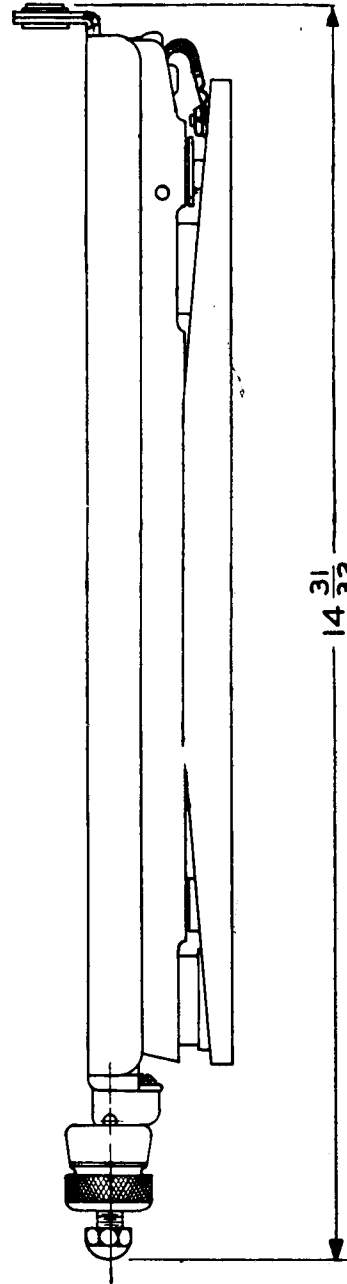
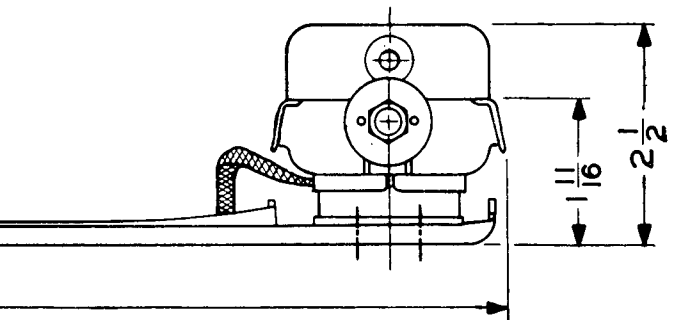
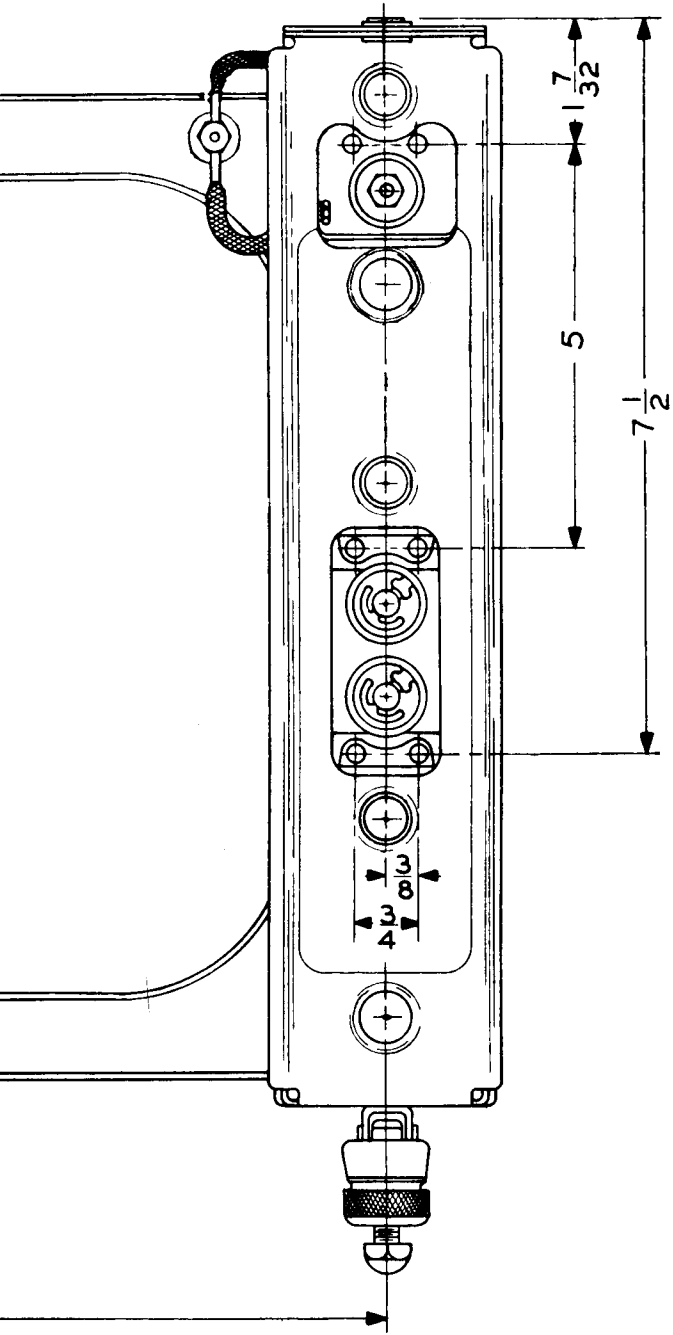
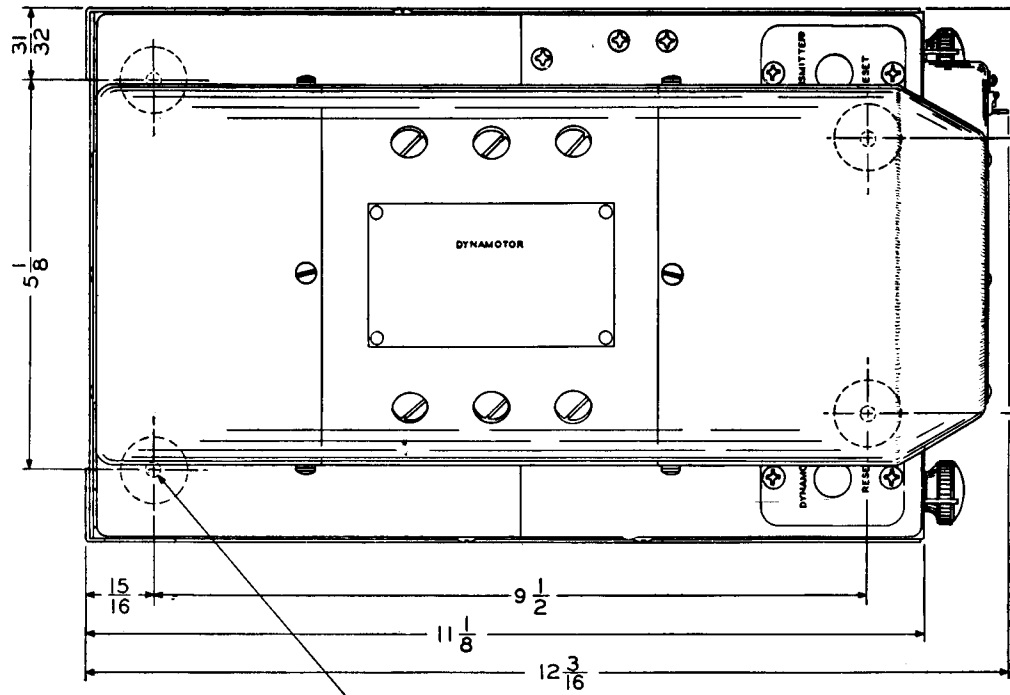

Figure 8-3. Type MT-284/ART-13  
Transmitter Shockmounting Base



AN 08-30ART13-5



MOUNTING HOLES FOR #10 SCREWS

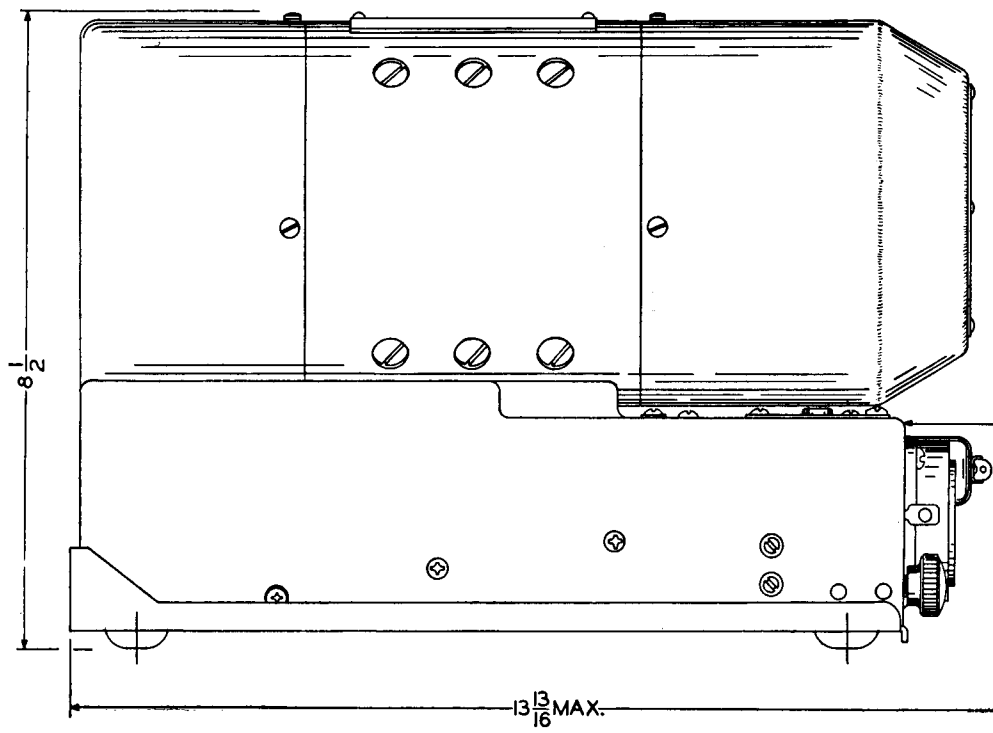

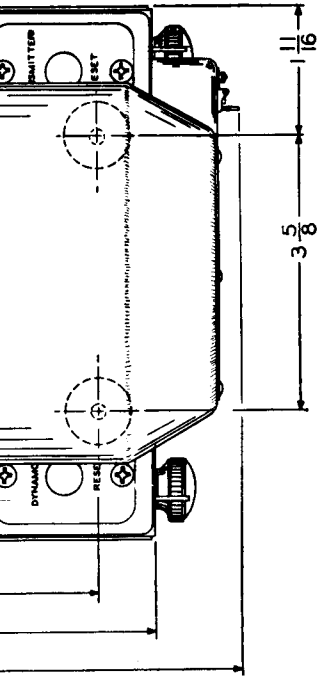

WEIGHT OF UNIT — 30 LBS.  $\pm$  2%

SCREWS

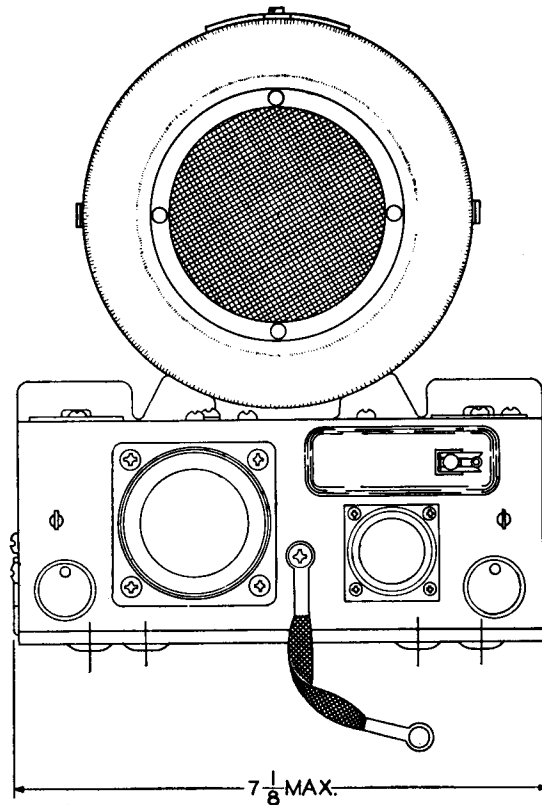
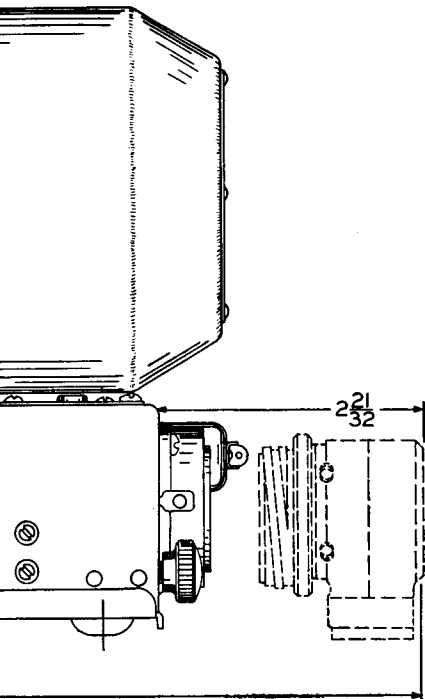
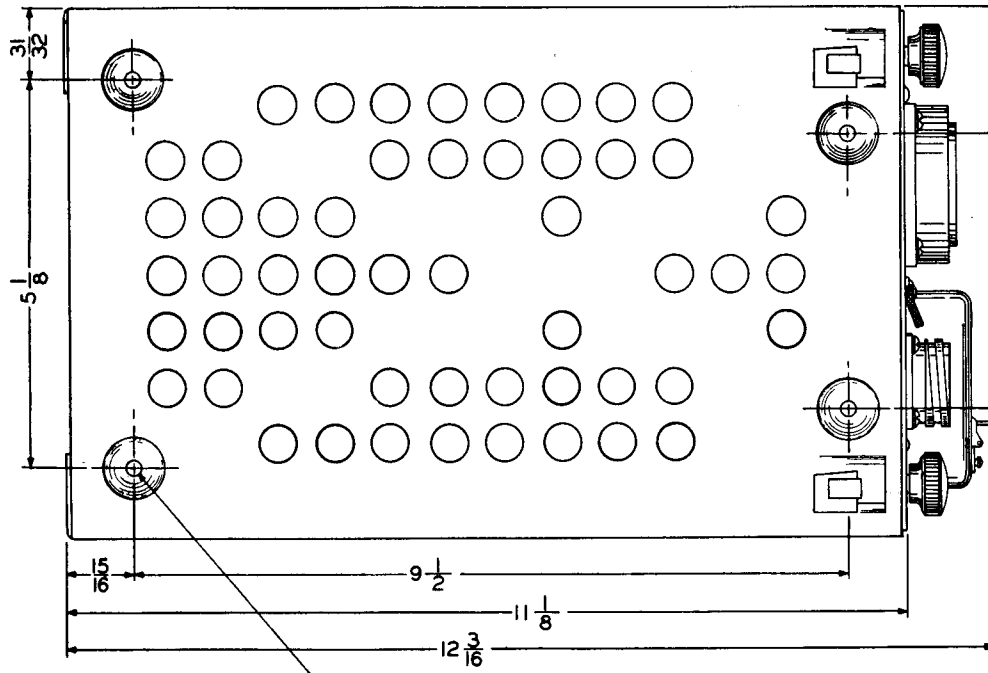
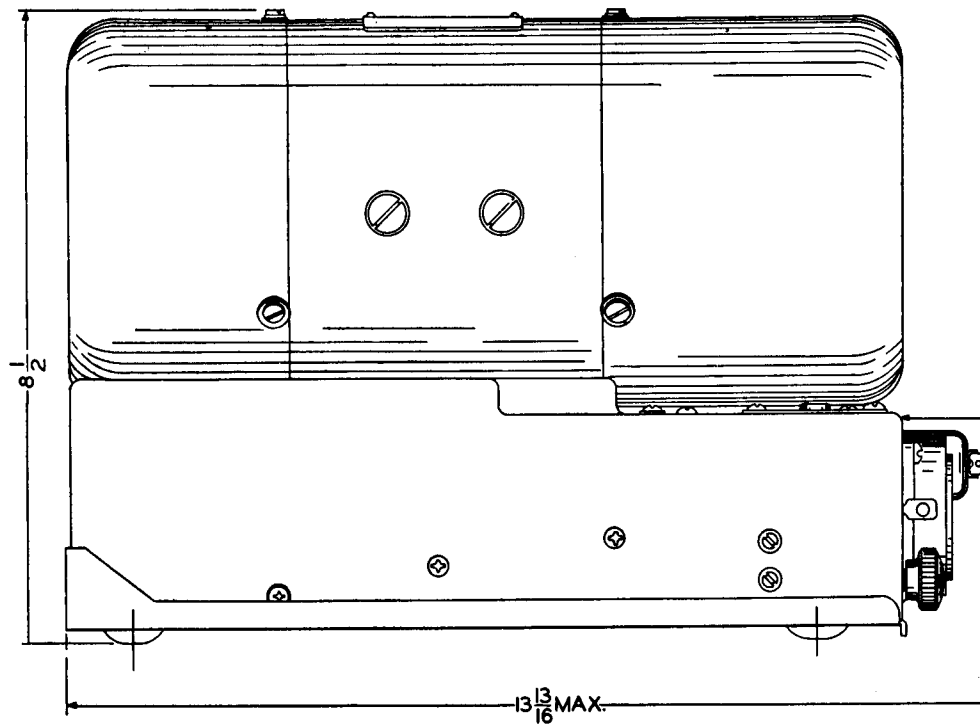

Figure 8-4. Type DY-11/ART-13 Dynamotor Power Unit Installation Diagram

AN 08-30ART13-5



MOUNTING HOLES FOR #10 SCREWS.



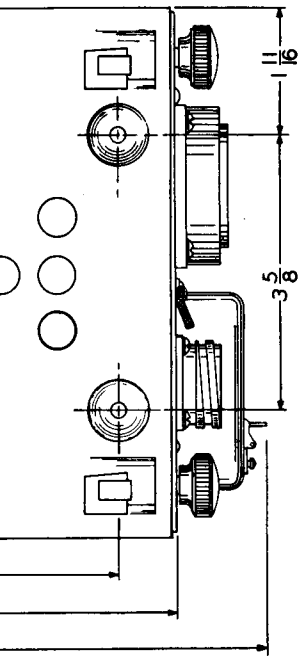

WEIGHT OF UNIT - 30 LBS.  $\pm$  2%

SCREWS.

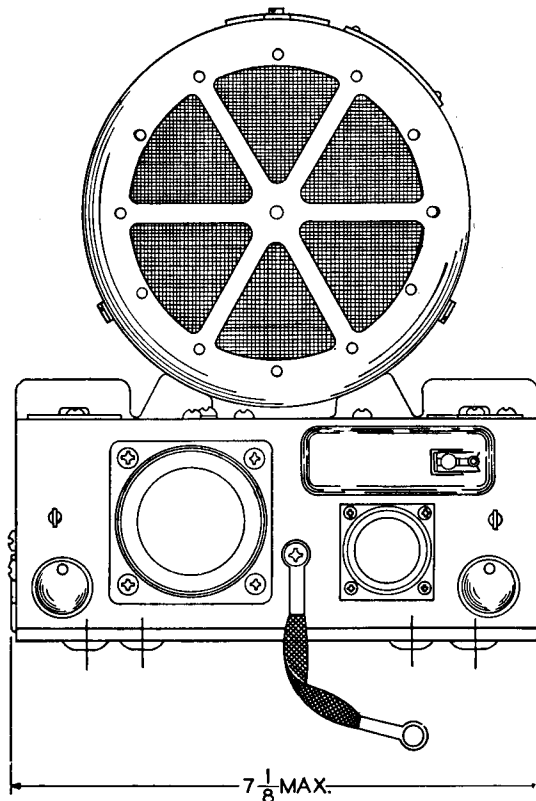
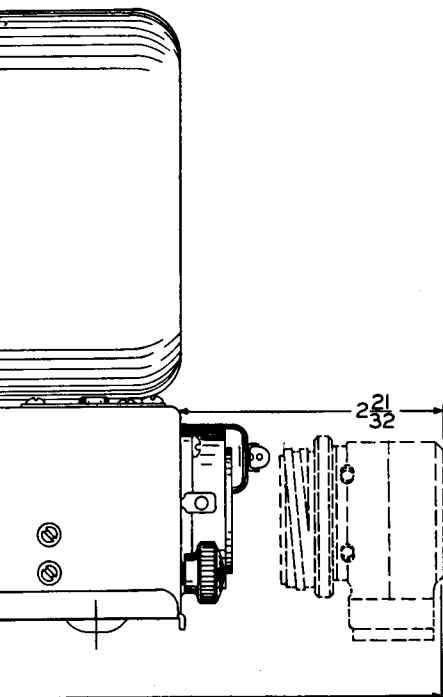
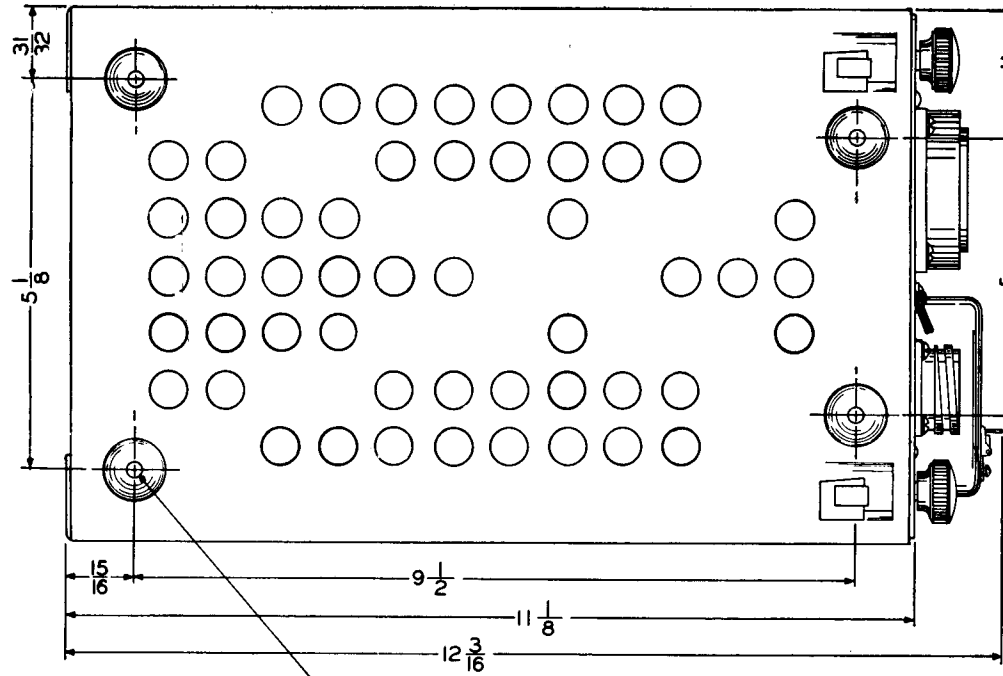
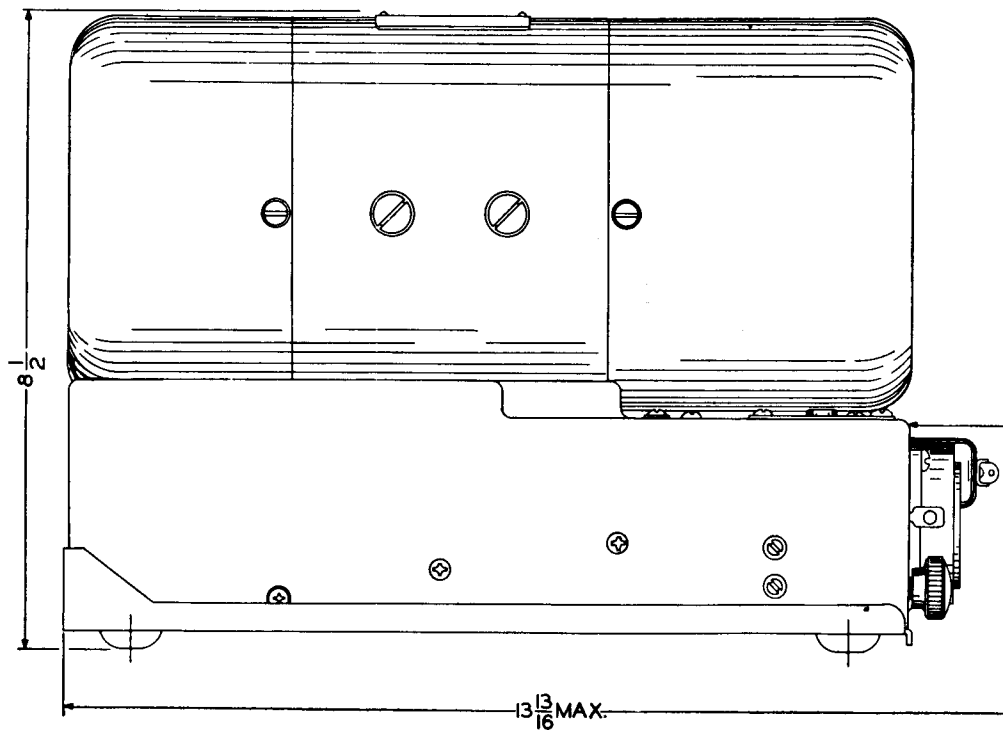

Figure 8-5. Type DY-12/ART-13 Dynamotor Power Unit Installation Diagram

AN 08-30ART13-5



MOUNTING HOLES FOR #10 SCREWS.



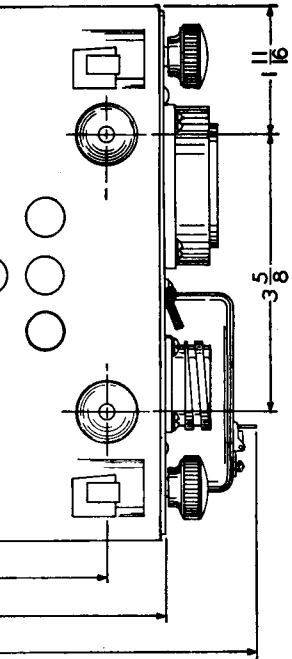

WEIGHT OF UNIT - 30 LBS.  $\pm$  2%

SCREWS.

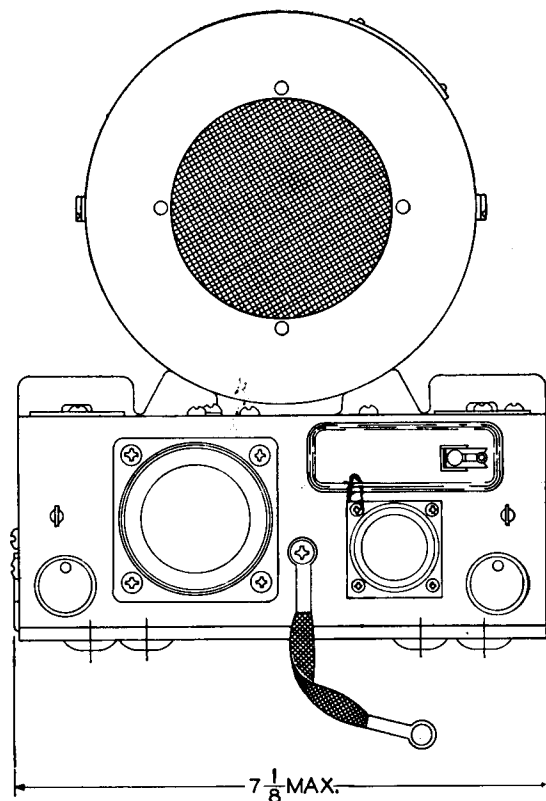
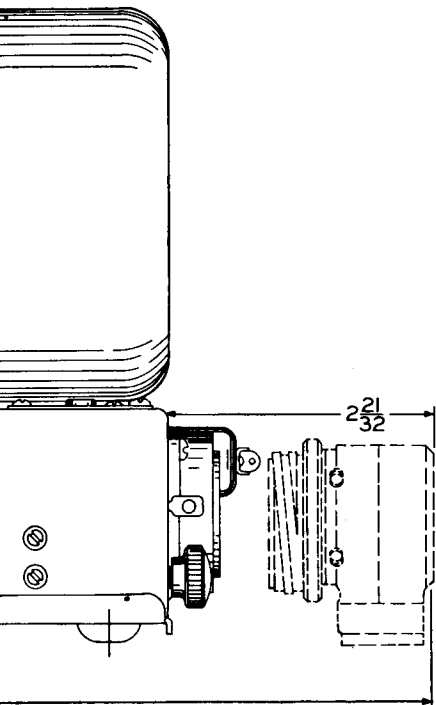

Figure 8-6. Type DY /ART-13 Dynamotor  
Power Unit Installation Diagram

AN 08-30ART13-5

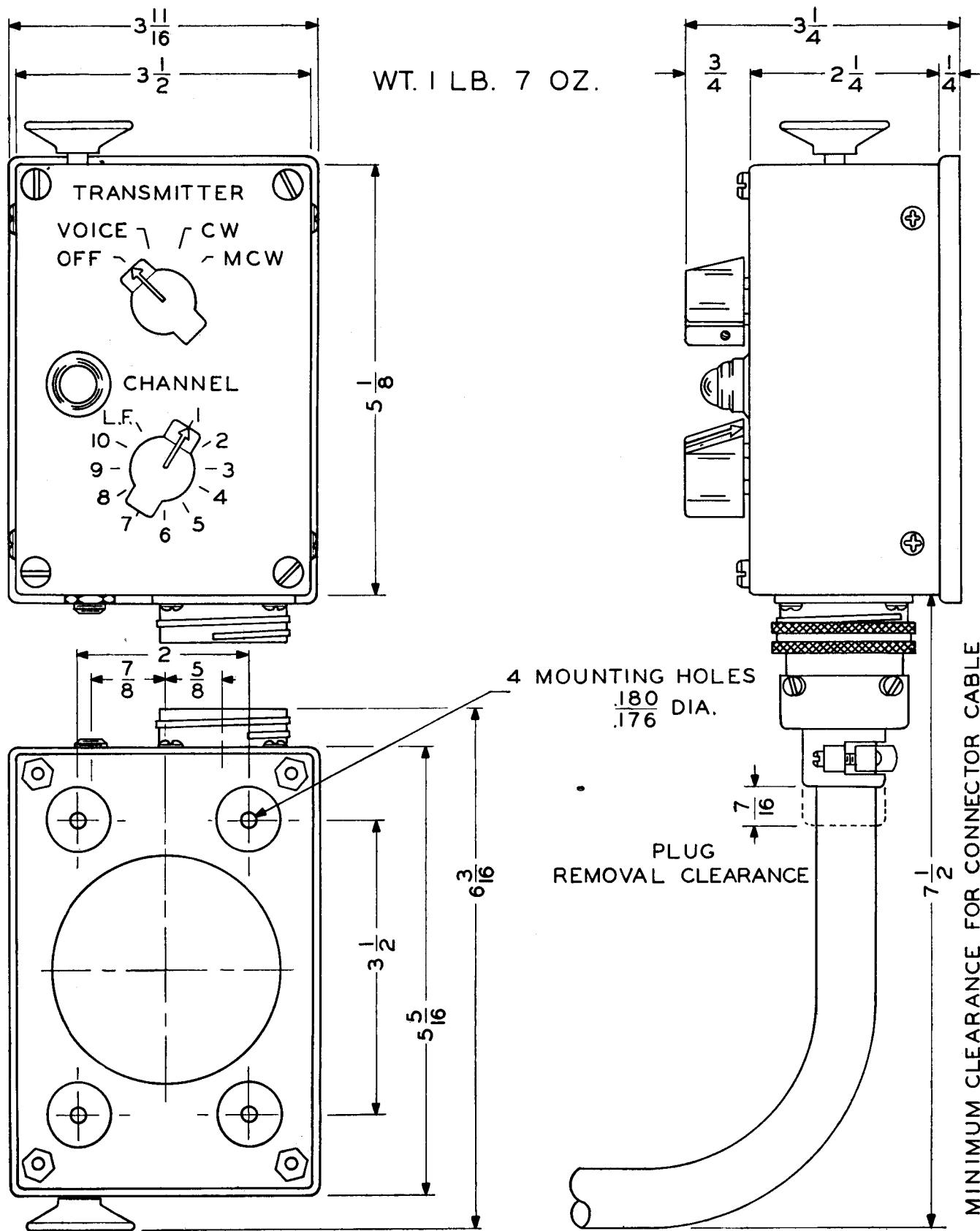
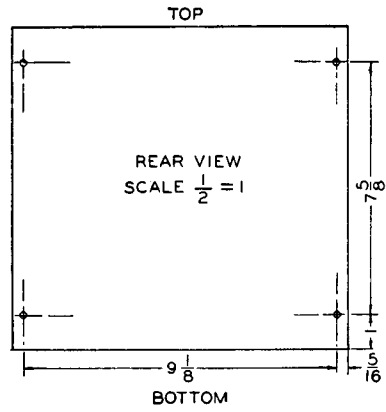

Figure 8-7. Type C-87/ART-13 Pilot's Control Unit Installation Diagram

AN 08-30ART13-5



WEIGHT 9 POUNDS, 12 OUNCES

DR. .177 DIA., NO. 16, 4 P  
ON EACH SIDE, TOP, BO  
REAR FOR NO. 8 SCREW

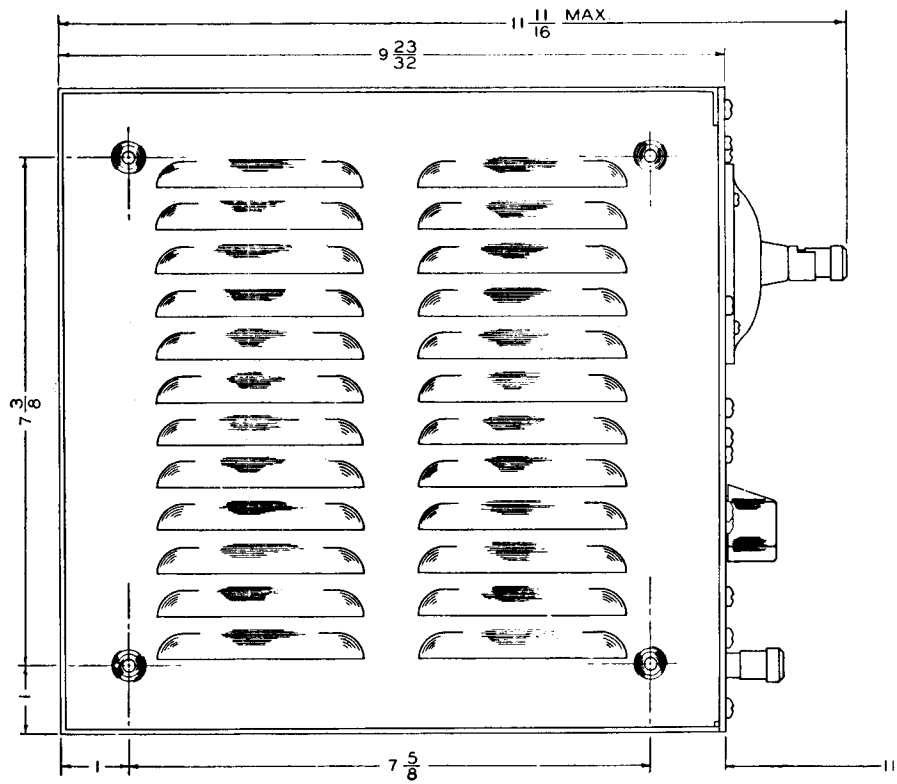

AMOUNT OF CLEARAN  
REMOVE PANEL AND



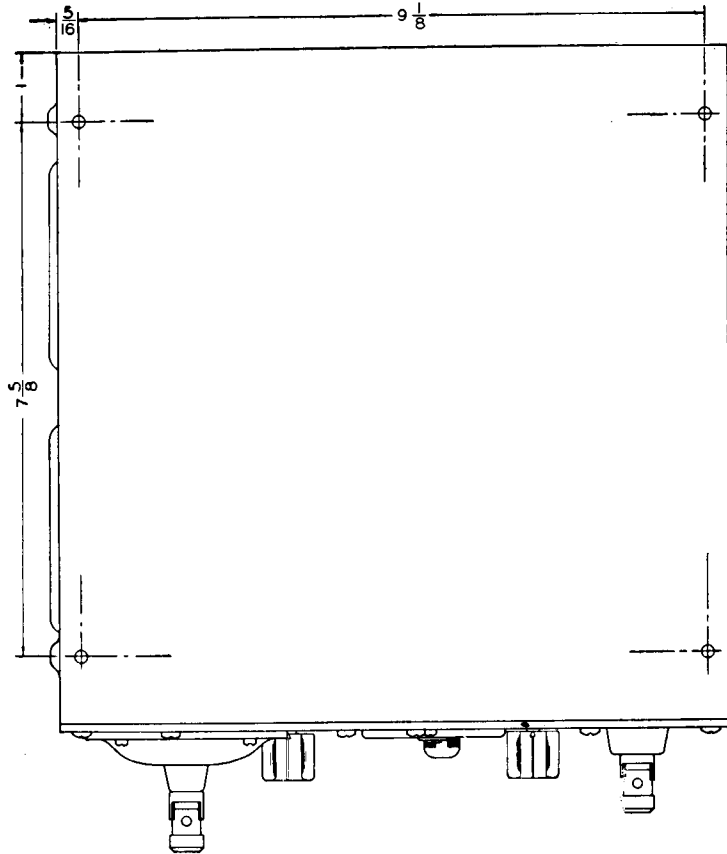

DS, 12 OUNCES

DR. .177 DIA., NO. 16, 4 MTG. HOLES  
ON EACH SIDE, TOP, BOTTOM AND  
REAR FOR NO. 8 SCREWS.

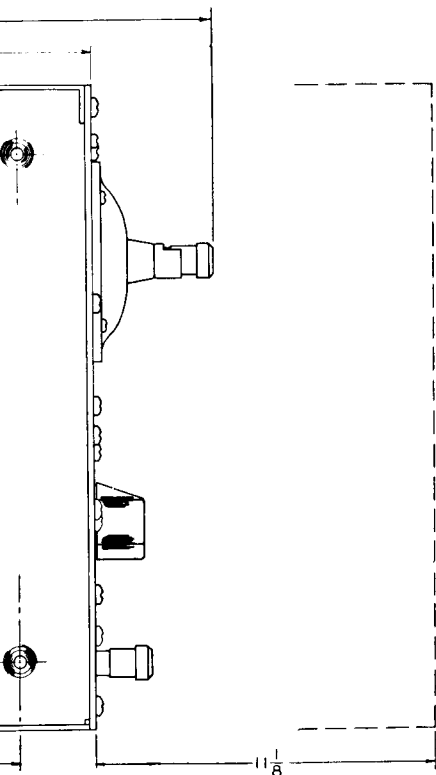

AMOUNT OF CLEARANCE NECESSARY TO  
REMOVE PANEL AND UNIT FROM COVER

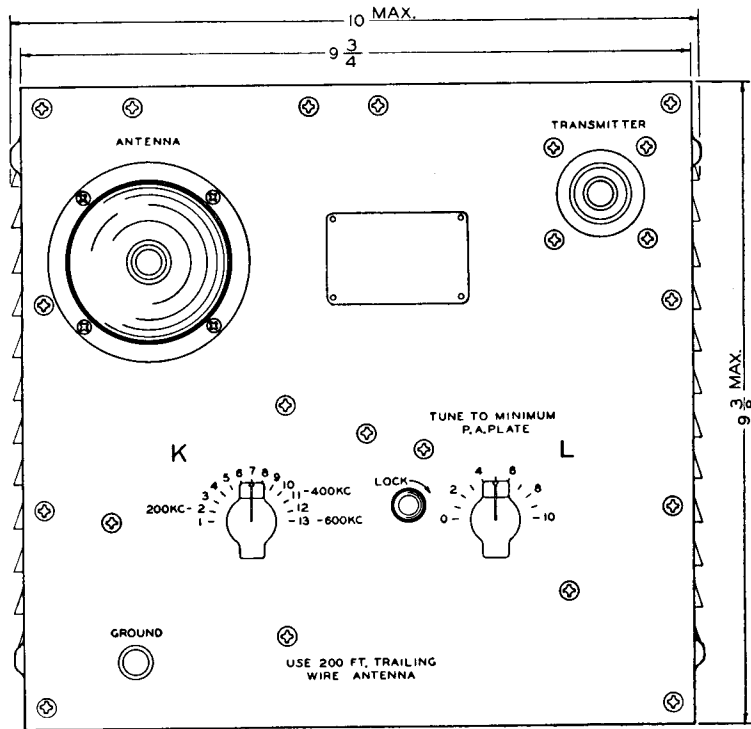

Figure 8-8. Type CU-25/ART-13  
Antenna Loading Coil Installation  
Diagram

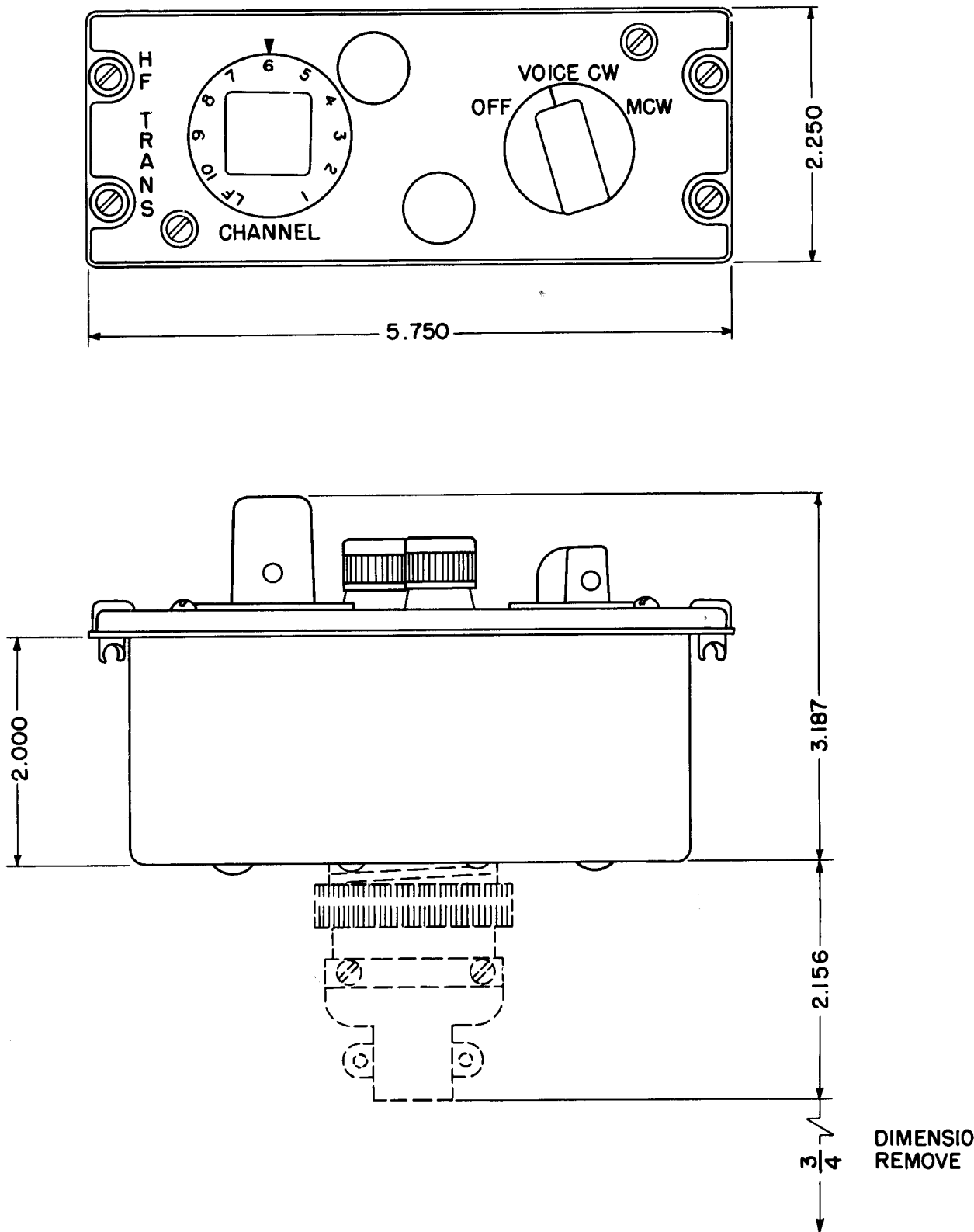
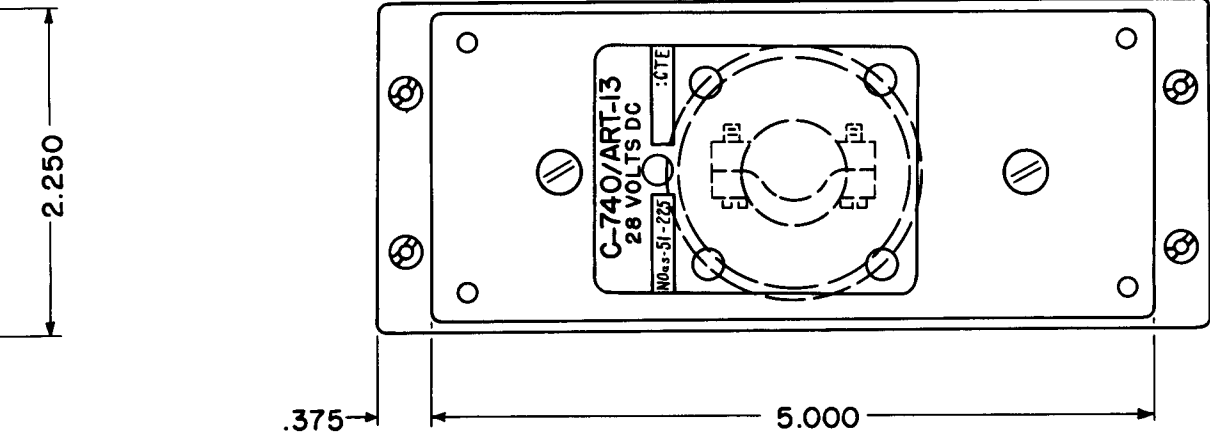

Figure 8-7A. Type C-740/ART-13 Pilot's Control Unit Installation Diagram

Revised 1 May 1953



BACK OF UNIT

ALL DIMENSIONS ARE IN INCHES

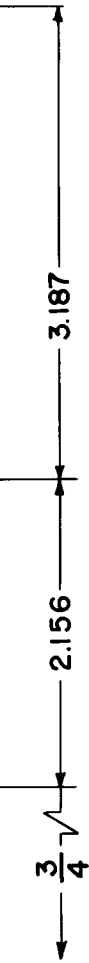

DIMENSION FOR CLEARANCE TO REMOVE PLUG FROM RECEPTACLE



$\frac{5}{16}$  DIA.  
8 MOUNTING HOLES

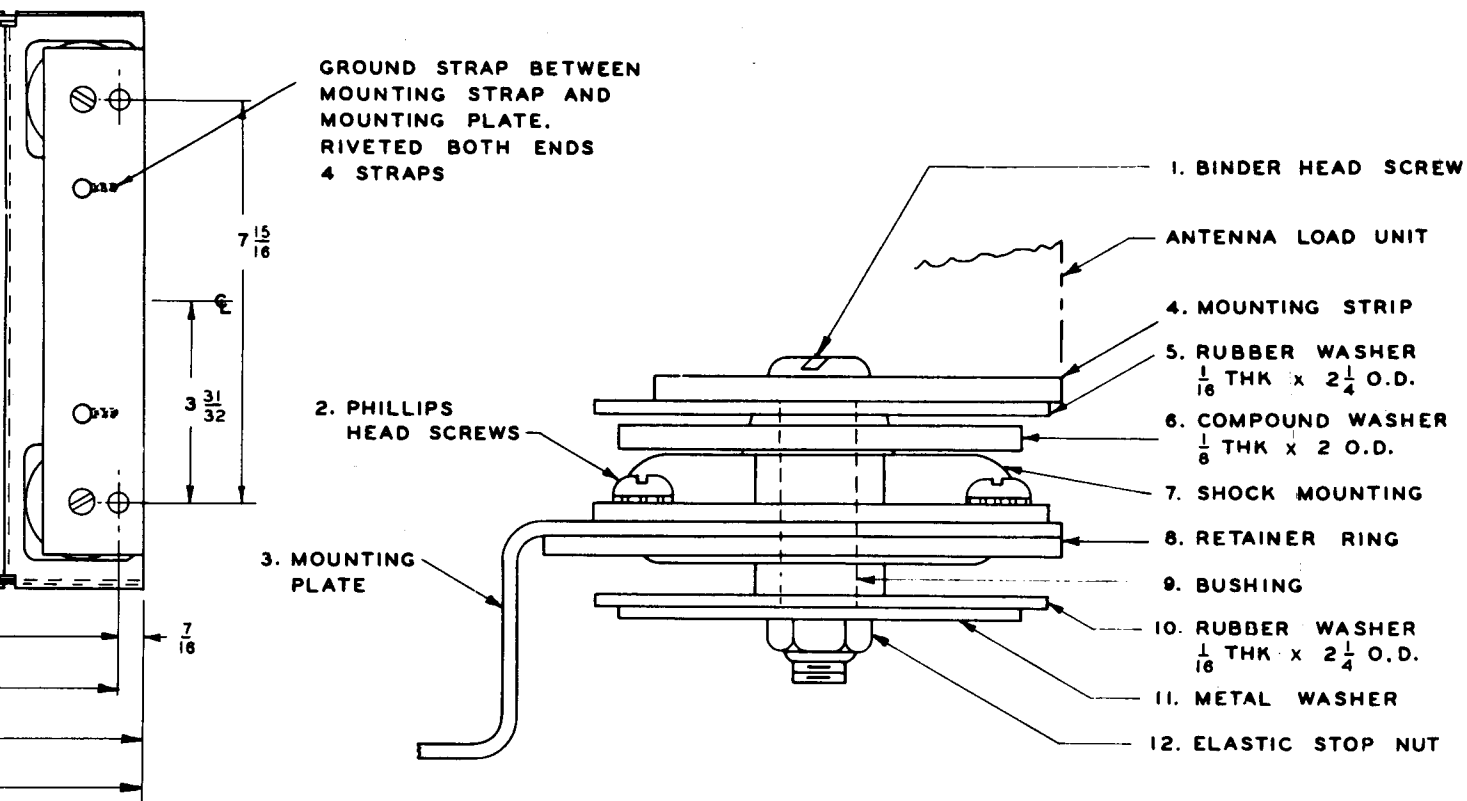

ENLARGED VIEW SHOWING BUILDING UP OF PARTS FOR BOTTOM MOUNTING  
SCALE (APPROX.) 2:1

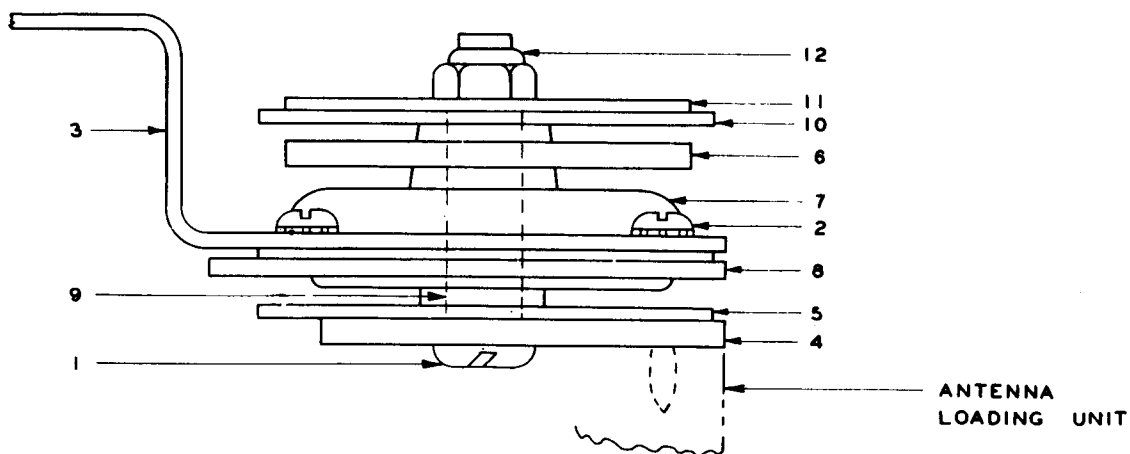
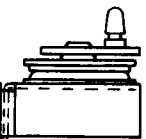

ENLARGED VIEW SHOWING BUILDING UP OF PARTS FOR OVERHEAD MOUNTING

NOTE NUMBERS REFER TO VIEW ABOVE

Figure 8-8A. Mounting Base MT-198/ART-13A—Outline Dimensions  
(for Antenna Loading Coil CU-32/ART-13A)

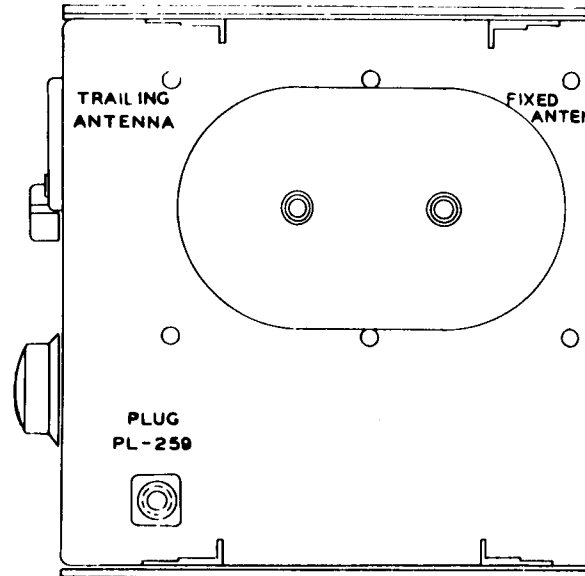

- LEADS TO FIXED ANTENNA, TRAILING ANTENNA AND H.F. INPUT MUST HAVE AT LEAST 1/4" CLEARANCE FROM ALL OTHER METALIC OBJECTS. LEAD TO L.F. INPUT MUST HAVE AT LEAST 3/4" CLEARANCE FROM ALL OTHER METALIC OBJECTS.
2. ADD 1/2" TO OVER-ALL HEIGHT WHEN ANTENNA LOADING UNIT IS ATTACHED TO SHOCK MOUNTING.

- GOVERNMENT FURNISHED SHOCK MOUNTING IS TO BE INSTALLED IN A HORIZONTAL PLANE. HOWEVER, THE ANTENNA LOADING UNIT MAY BE INVERTED WITH THE ANTENNA LOADING UNIT BEING SUSPENDED FROM IT. ANTENNA LOADING UNIT MAY BE ATTACHED TO MOUNTING ON ANY ONE OF THE THREE SIDES AND IS DESIGNED FOR OPERATION IN ANY POSITION.
1. ANTENNA LOADING UNIT MAY BE ATTACHED TO MOUNTING ON ANY ONE OF THE THREE SIDES AND IS DESIGNED FOR OPERATION IN ANY POSITION.

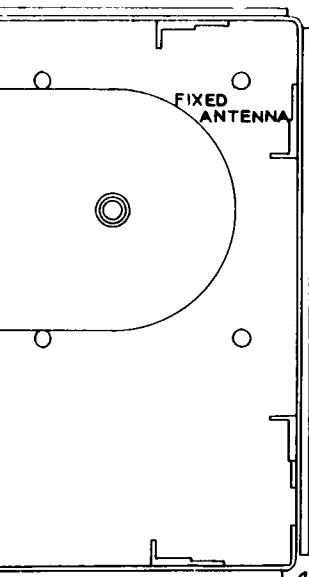

ALLOW 1 TO REMOVE PLUG

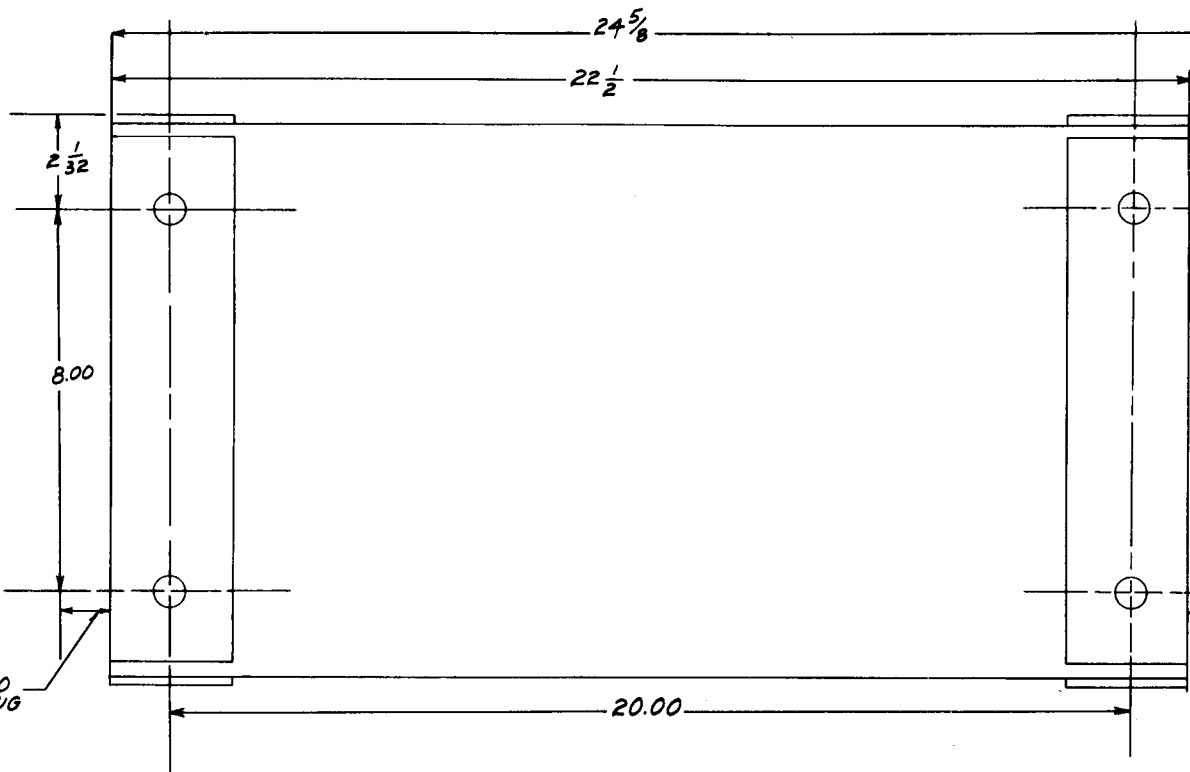

TRAILING ANTENNA  
MAY HAVE AT LEAST 1 1/2"  
CLEARANCE FROM OTHER METALIC OBJECTS.  
TRAILING ANTENNA MUST HAVE AT LEAST 3/4" CLEARANCE.

HEIGHT WHEN ANTENNA  
ATTACHED TO SHOCK MOUNT.

SHOCK MOUNTING MUST BE  
IN HORIZONTAL PLANE. HOWEVER IT MAY  
BE ATTACHED TO THE ANTENNA LOADING UNIT  
IF THE ANTENNA LOADING UNIT MAY  
OPERATE ON ANY ONE OF ITS  
DESIGNED FOR OPERATION

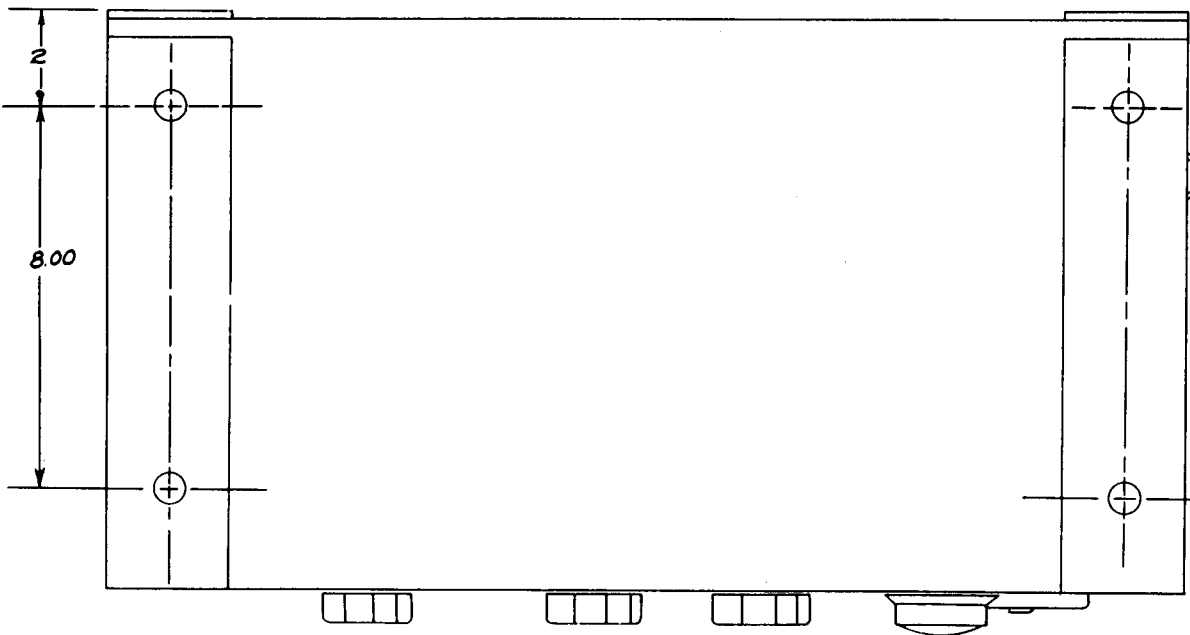

WEIGHT 25.12 LBS

Figure 8-8B.

Revised 15 July 1954

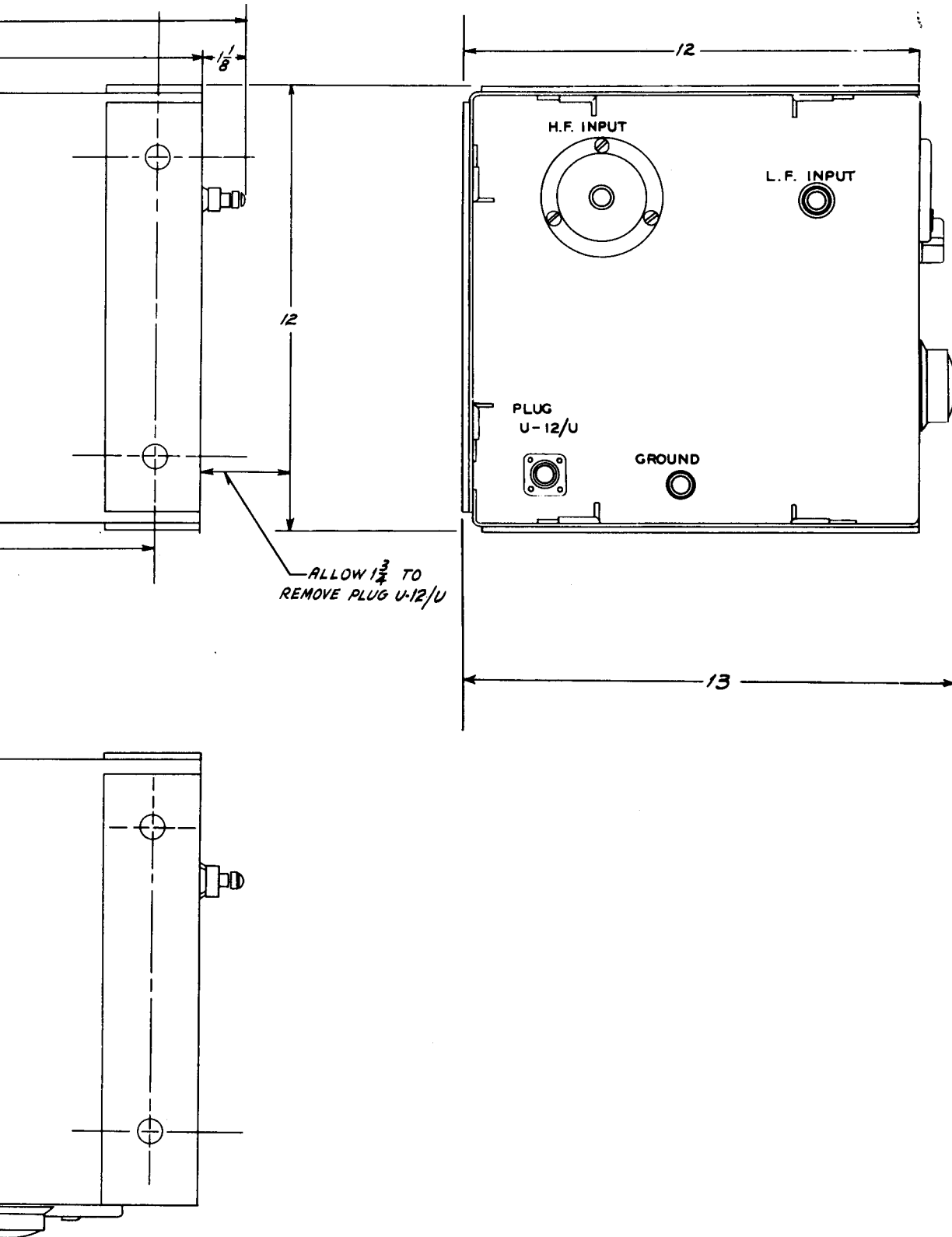

Figure 8-8B. Antenna Loading Coil CU-32/ART-13A—Outline Dimensions



WEIGHT: 3 POUNDS 7 OZ.

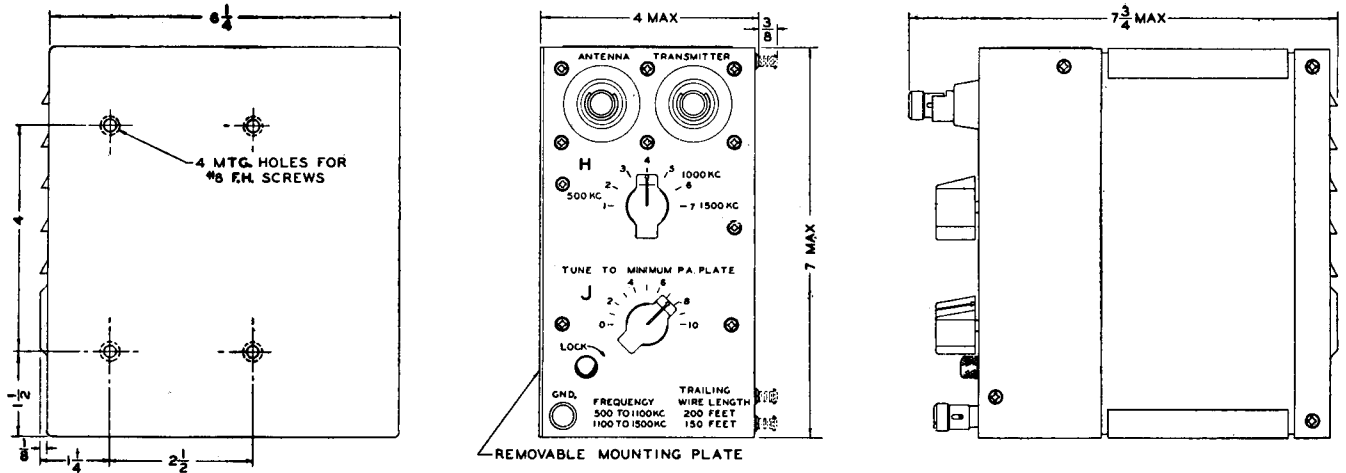

Figure 8-9. Type CU-26/ART-13 Antenna Loading Coil Installation Diagram

WEIGHT: 1 POUND 9.5 OZ.

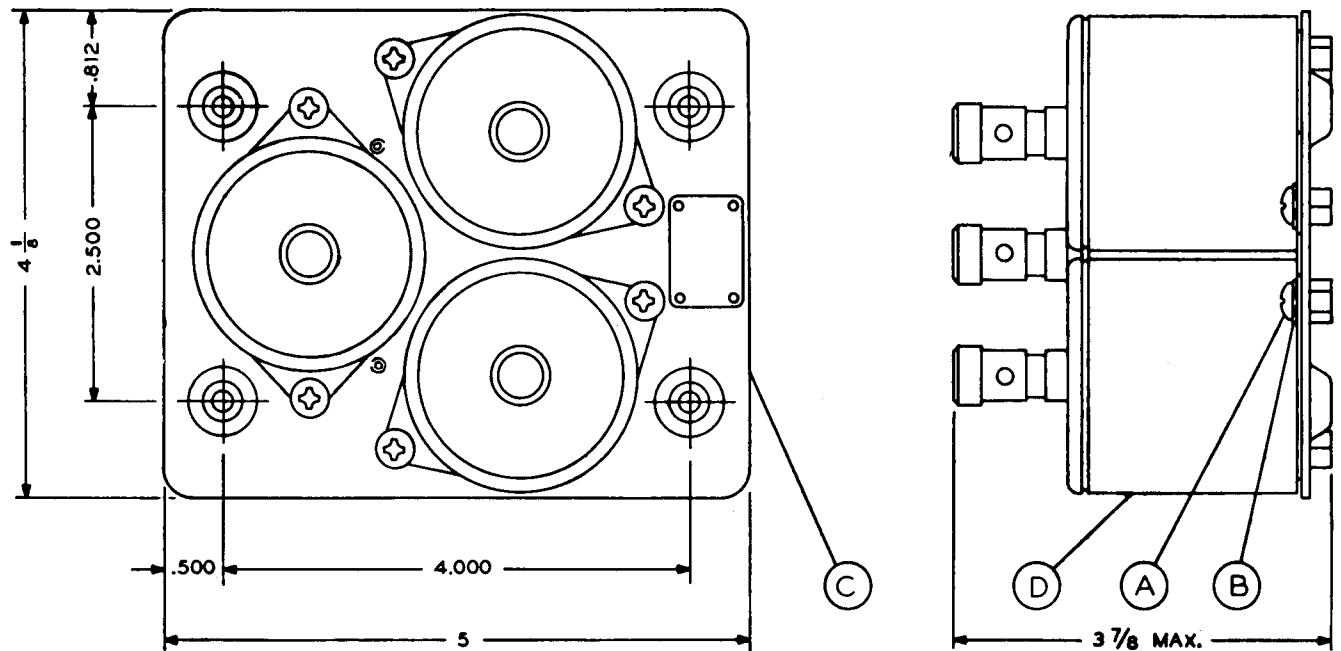
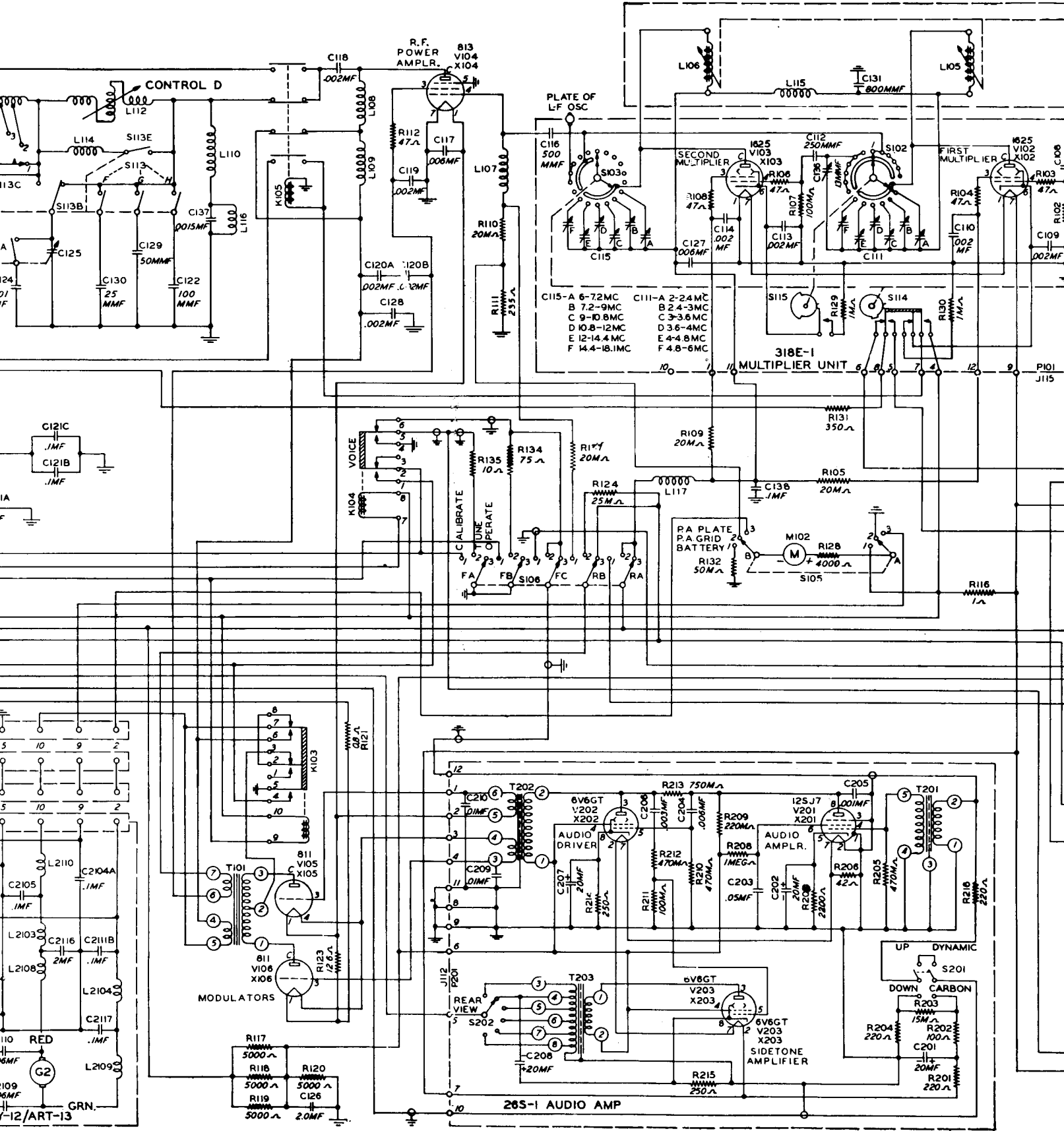
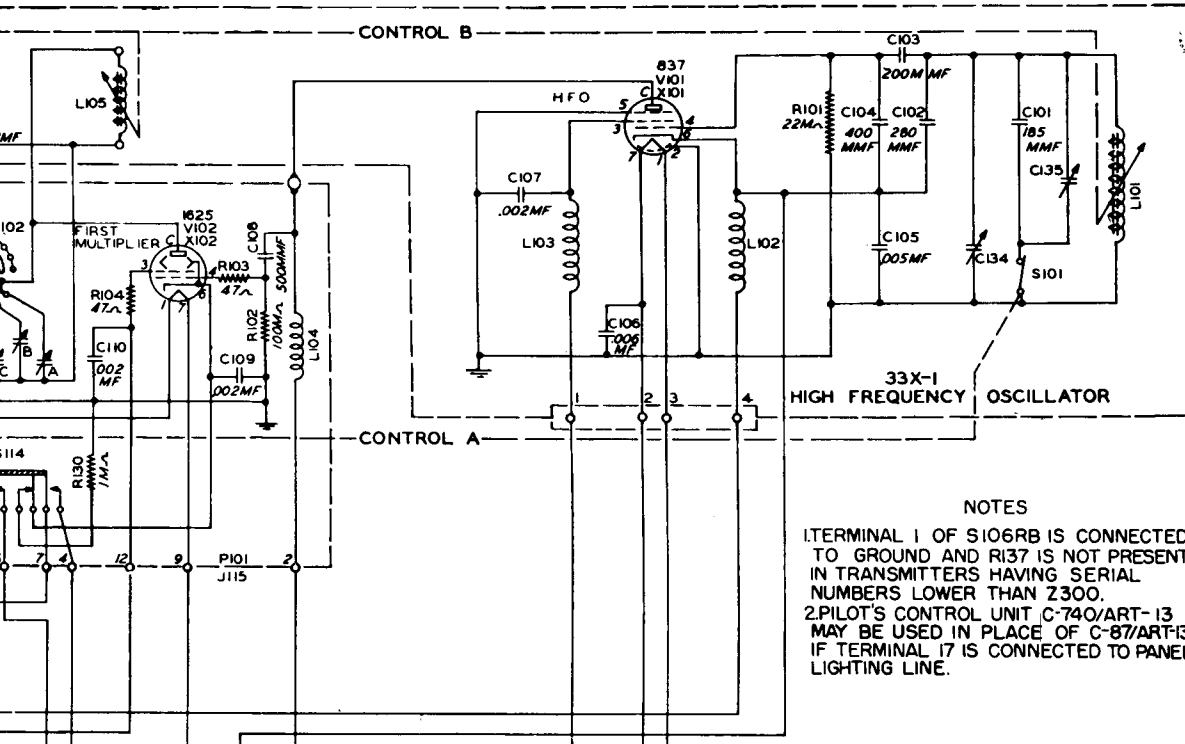

Figure 8-10. Type CU-24/ART-13 Antenna Shunt Capacitor Installation Diagram







NOTES  
 1. TERMINAL 1 OF S106RB IS CONNECTED TO GROUND AND R137 IS NOT PRESENT IN TRANSMITTERS HAVING SERIAL NUMBERS LOWER THAN Z300.  
 2. PILOT'S CONTROL UNIT C-740/ART-13 MAY BE USED IN PLACE OF C-87/ART-13 IF TERMINAL 17 IS CONNECTED TO PANEL LIGHTING LINE.

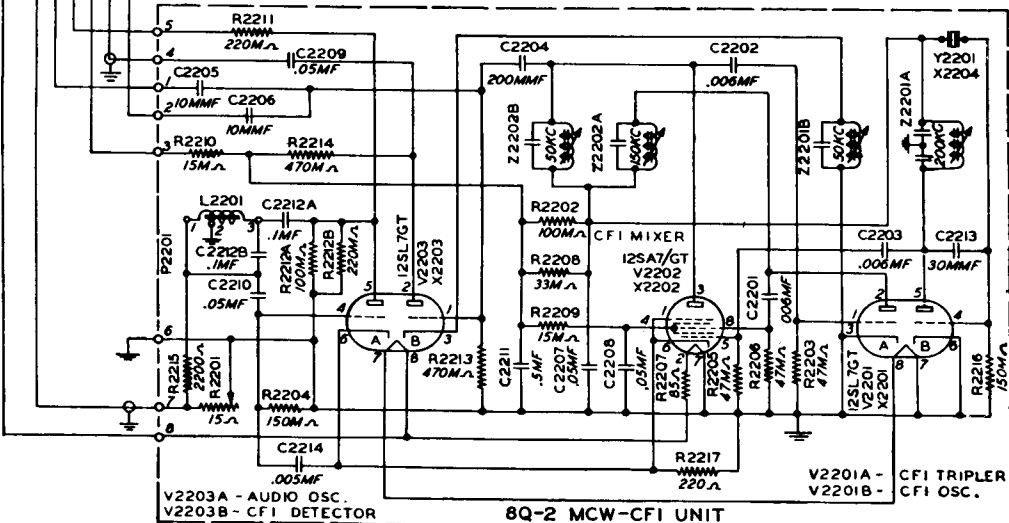
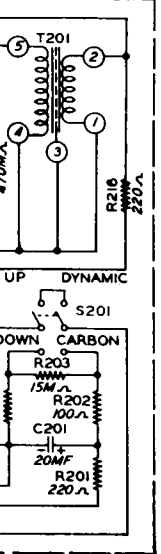
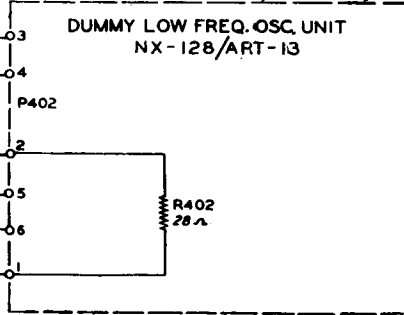

V2203A - AUDIO OSC.  
 V2203B - CF1 DETECTOR  
 8Q-2 MCW-CFI UNIT  
 V2201A - CF1 TRIPLER  
 V2201B - CF1 OSC.

AN 08-30ART13-5

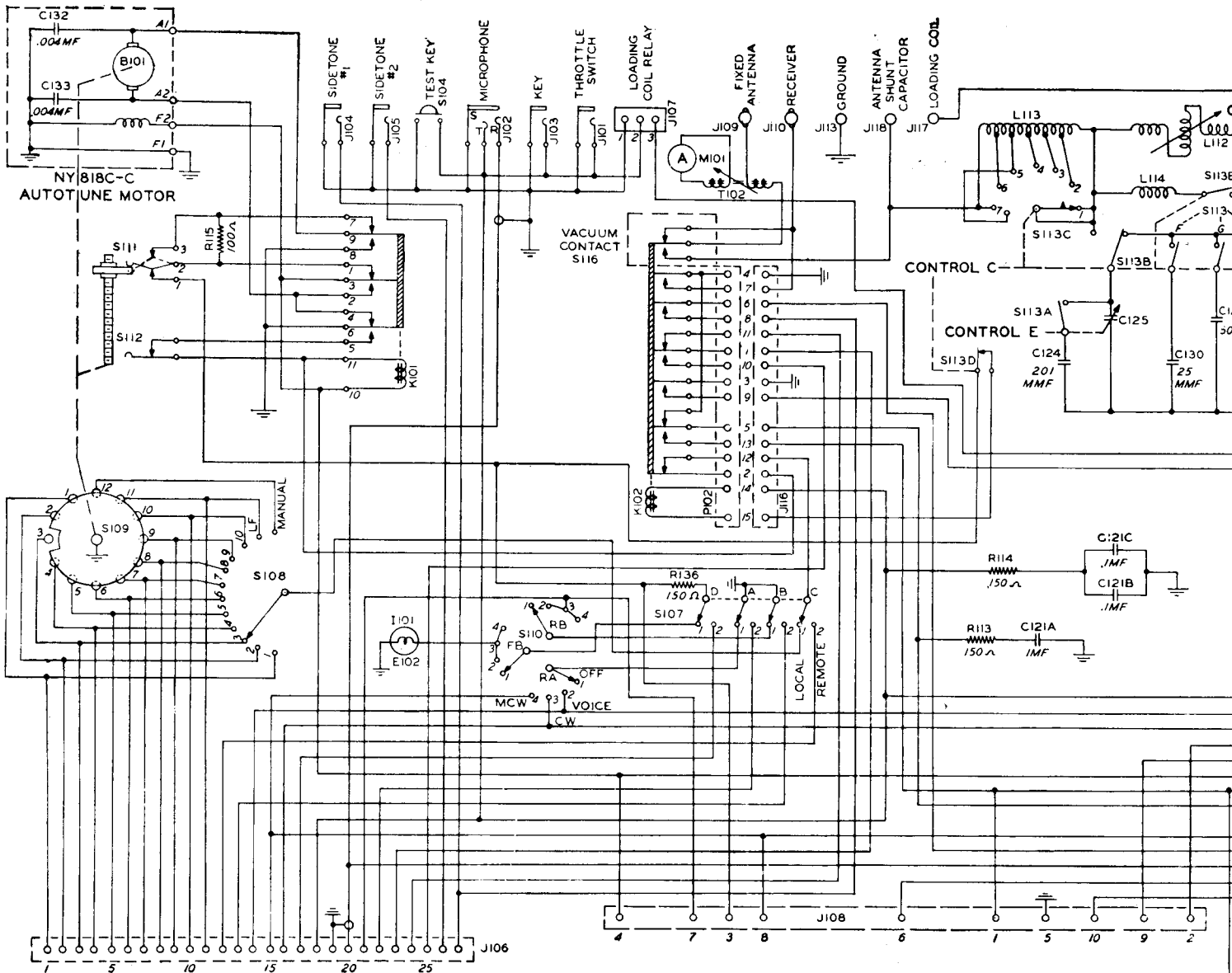

AN 08-30ART13-5

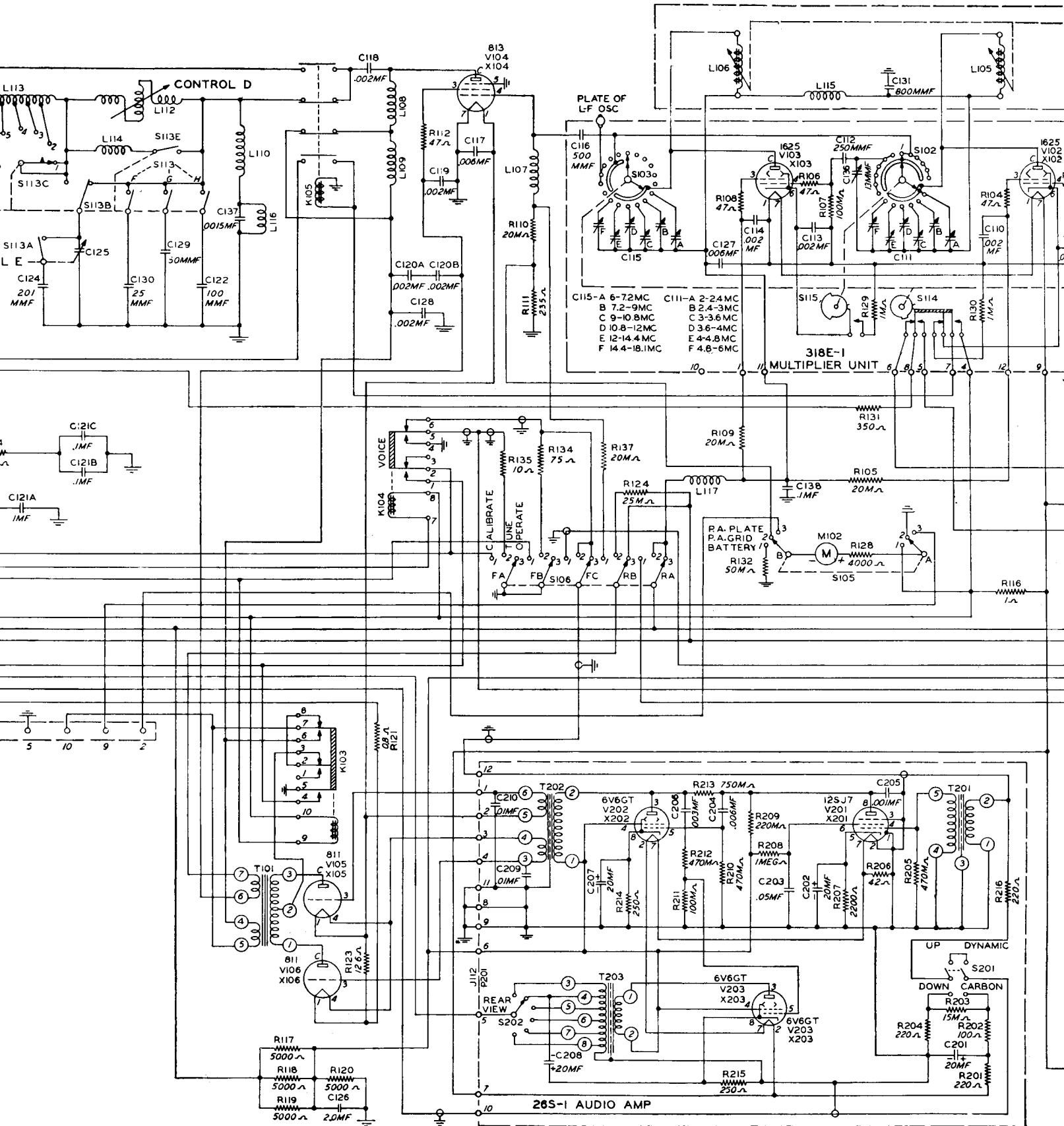



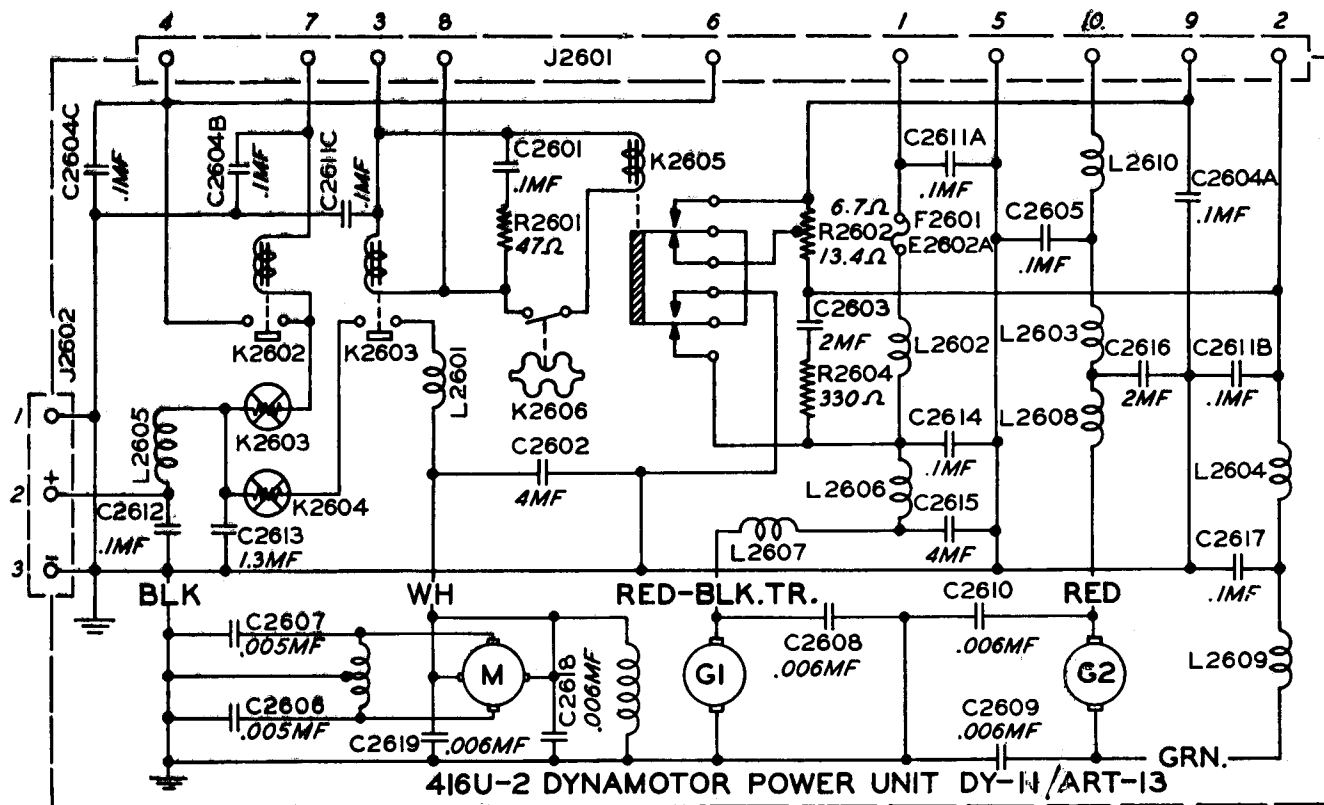

Figure 8-13. Type DY-11/ART-13 Dynamotor Power Unit Schematic

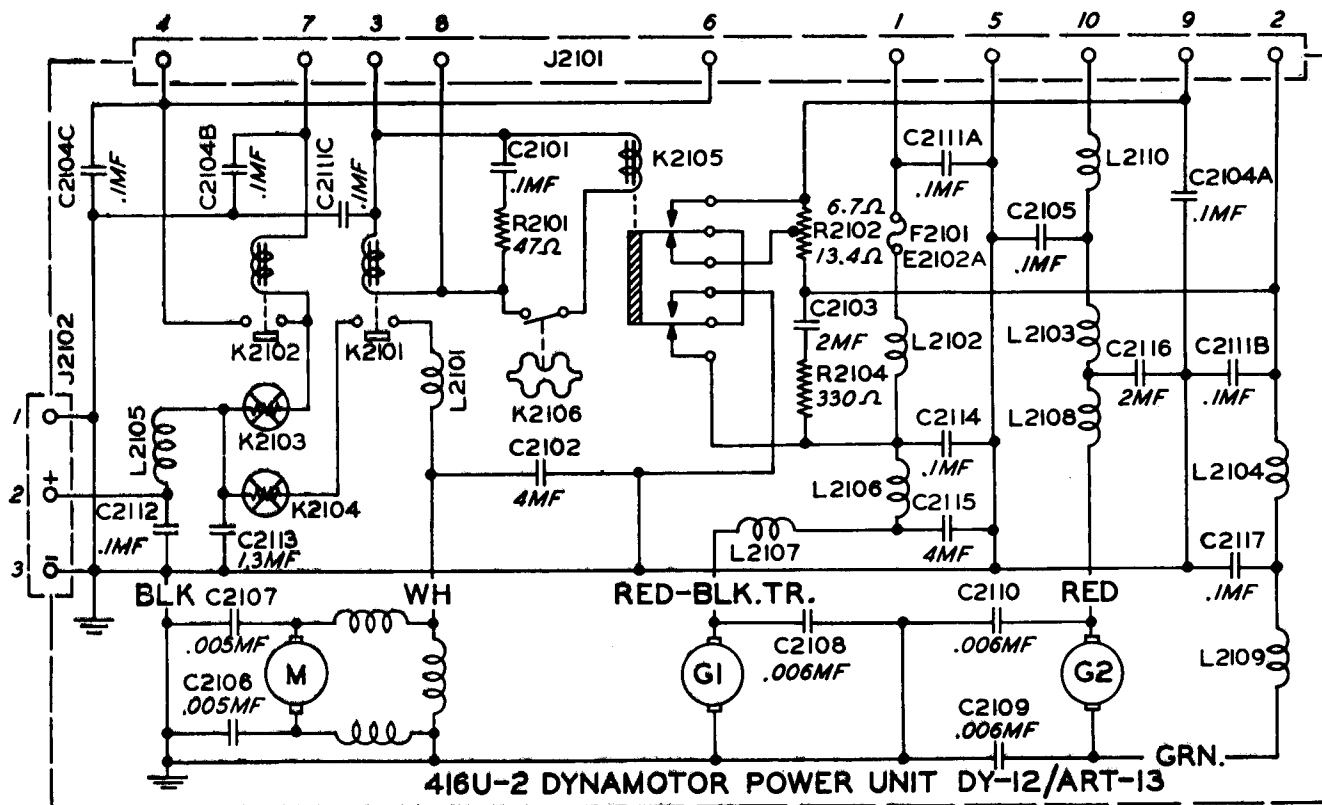

Figure 8-14. Type DY-12/ART-13 Dynamotor Power Unit Schematic



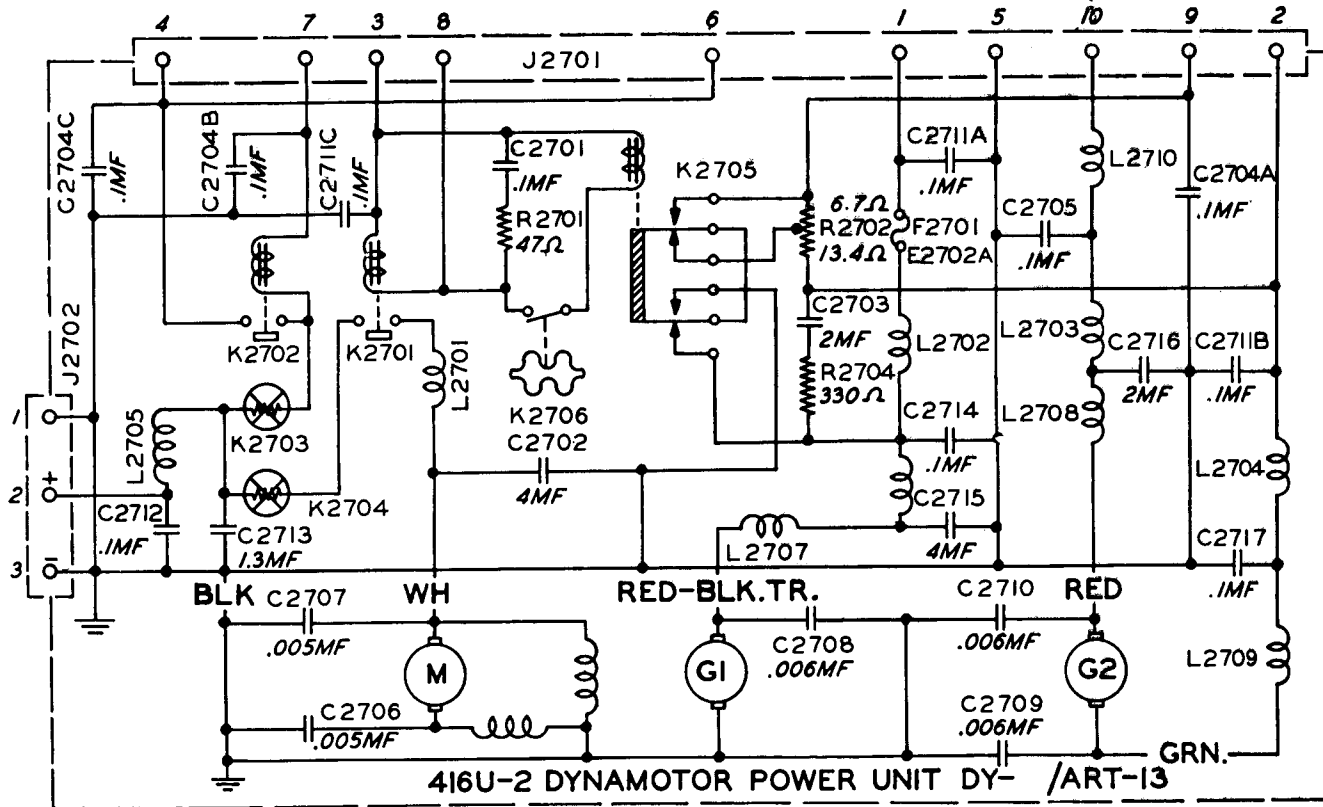
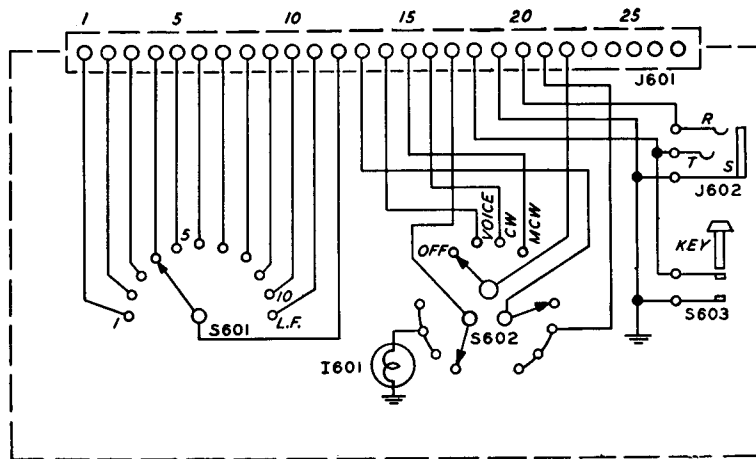
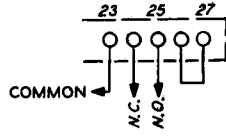

Figure 8-15. Type DY- /ART-13 Dynamotor Power Unit Schematic



J601 CONNECTION FOR SINGLE KEYED SIDETONE PLUS RECEIVING DISABLING CIRCUIT



J601 CONNECTION FOR INDIVIDUAL KEYING OF DOUBLE SIDETONE AT JACKS J104 AND J105

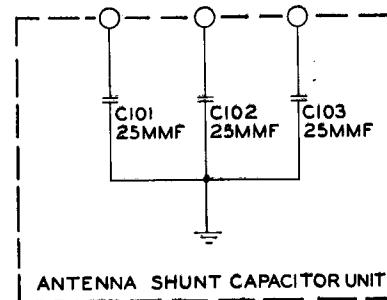
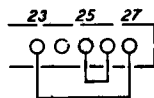

Figure 8-17. Type CU-24/ART-13 Antenna Shunt Capacitor Unit Schematic

Figure 8-16. Type C-87/ART-13 Pilot's Control Unit Schematic

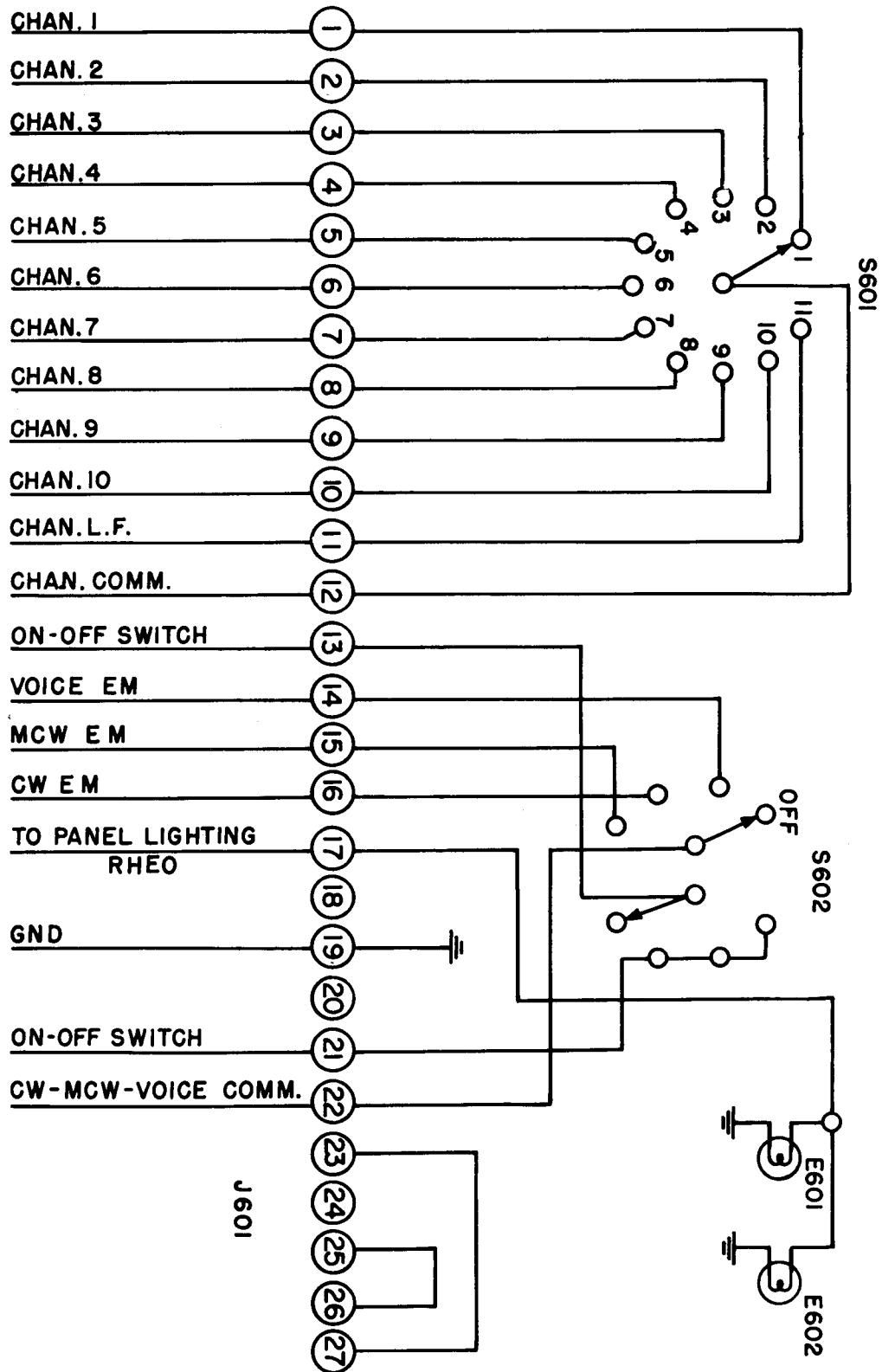

Figure 8-16A. Type C-740/ART-13 Pilot's Control Unit Schematic

Revised 1 May 1953

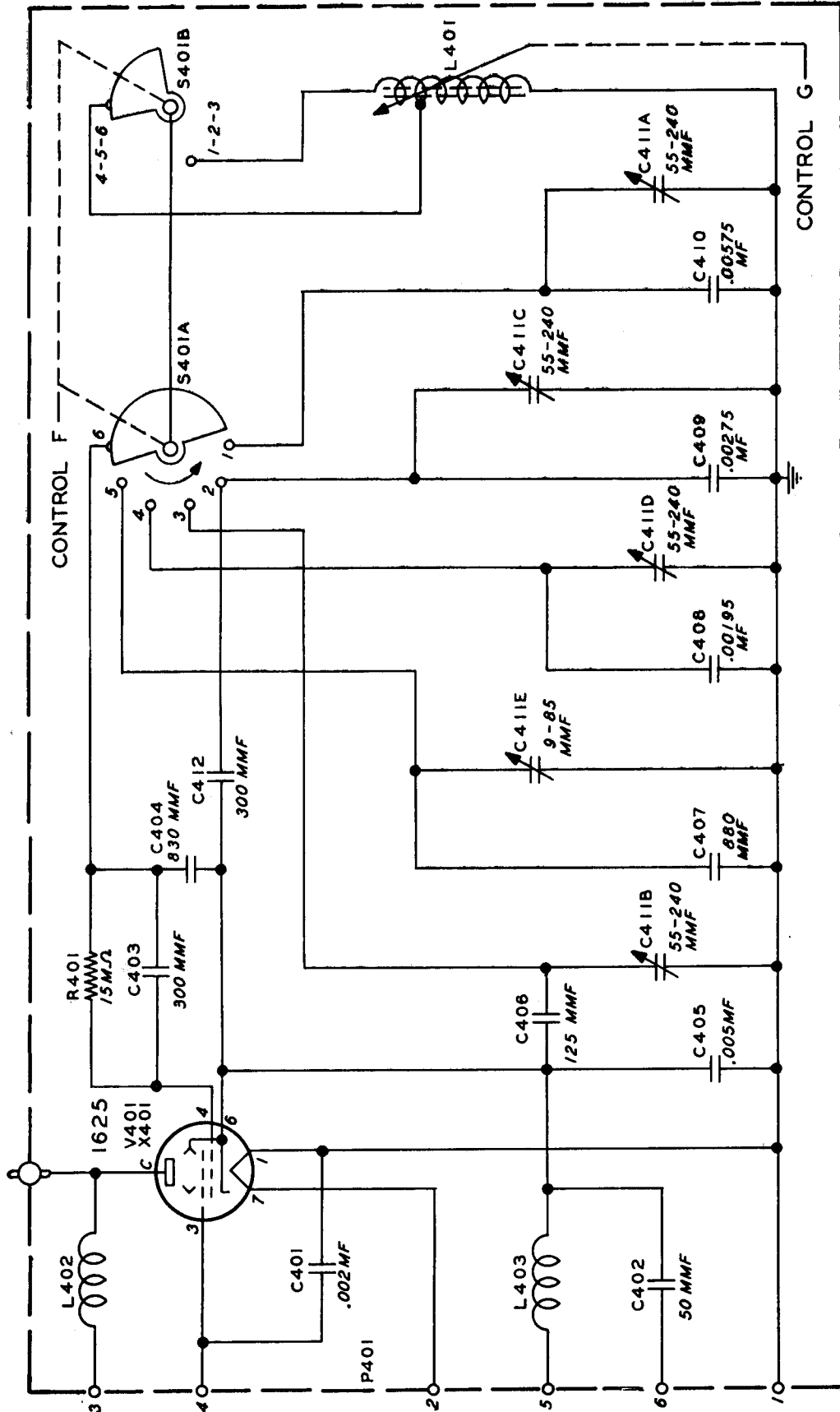

Figure 8-18. Type O-16/ART-13 Low Frequency Oscillator Unit Schematic

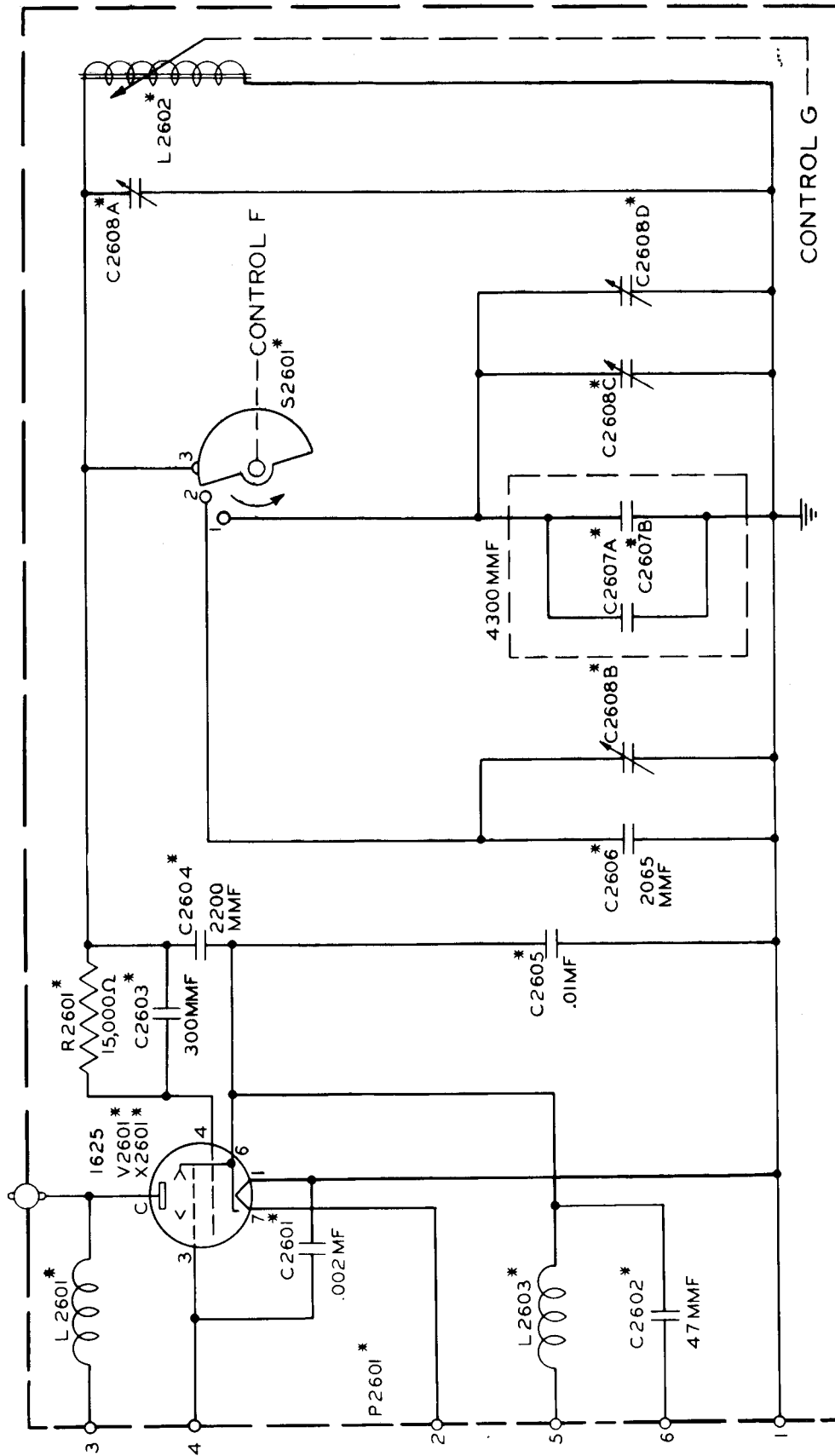

Figure 8-18A. Type O-17/ART-13A Low Frequency Oscillator Unit Schematic

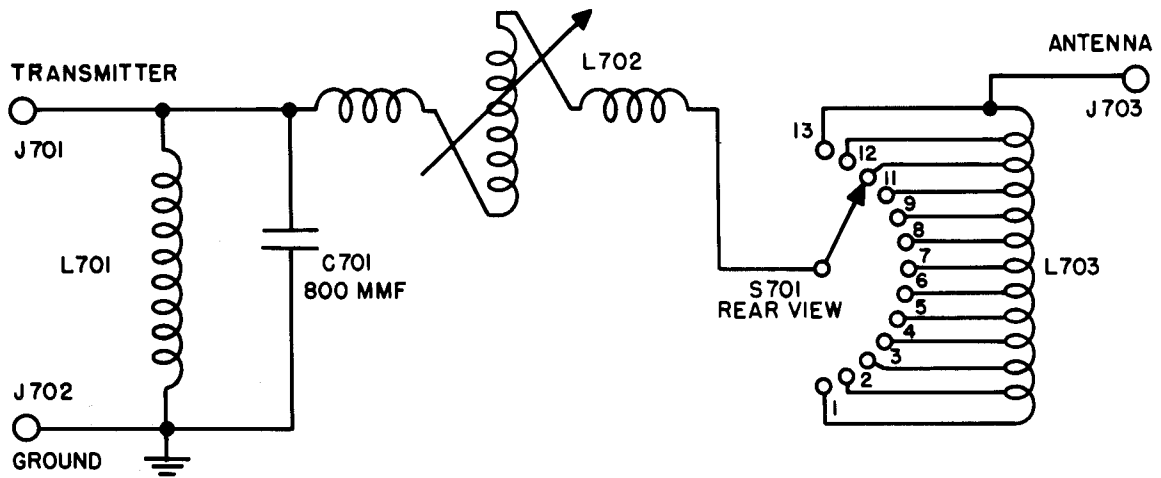

Figure 8-19. Type CU-25/ART-13 Antenna Loading Coil Unit Schematic

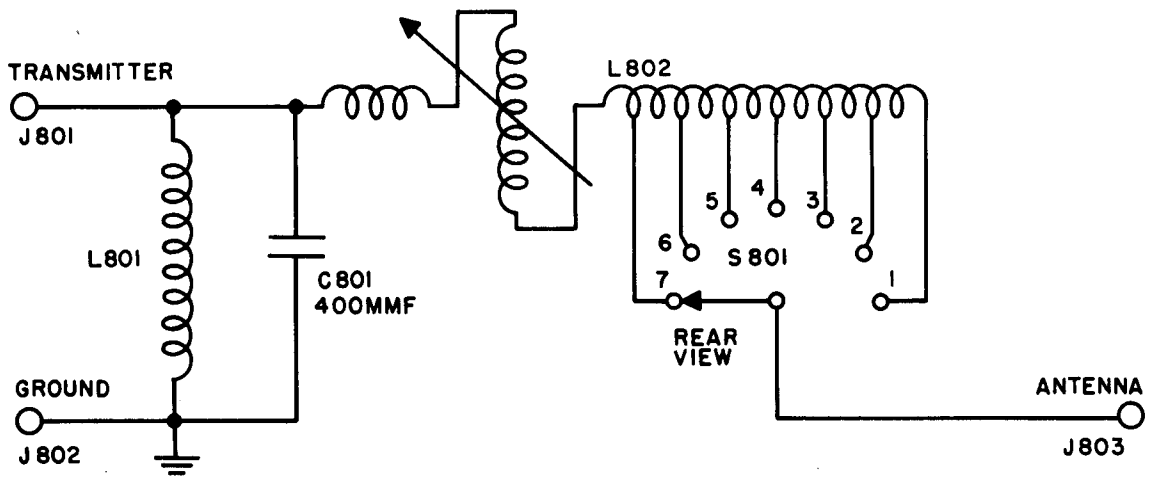

Figure 8-20. Type CU-26/ART-13 Antenna Loading Coil Unit Schematic

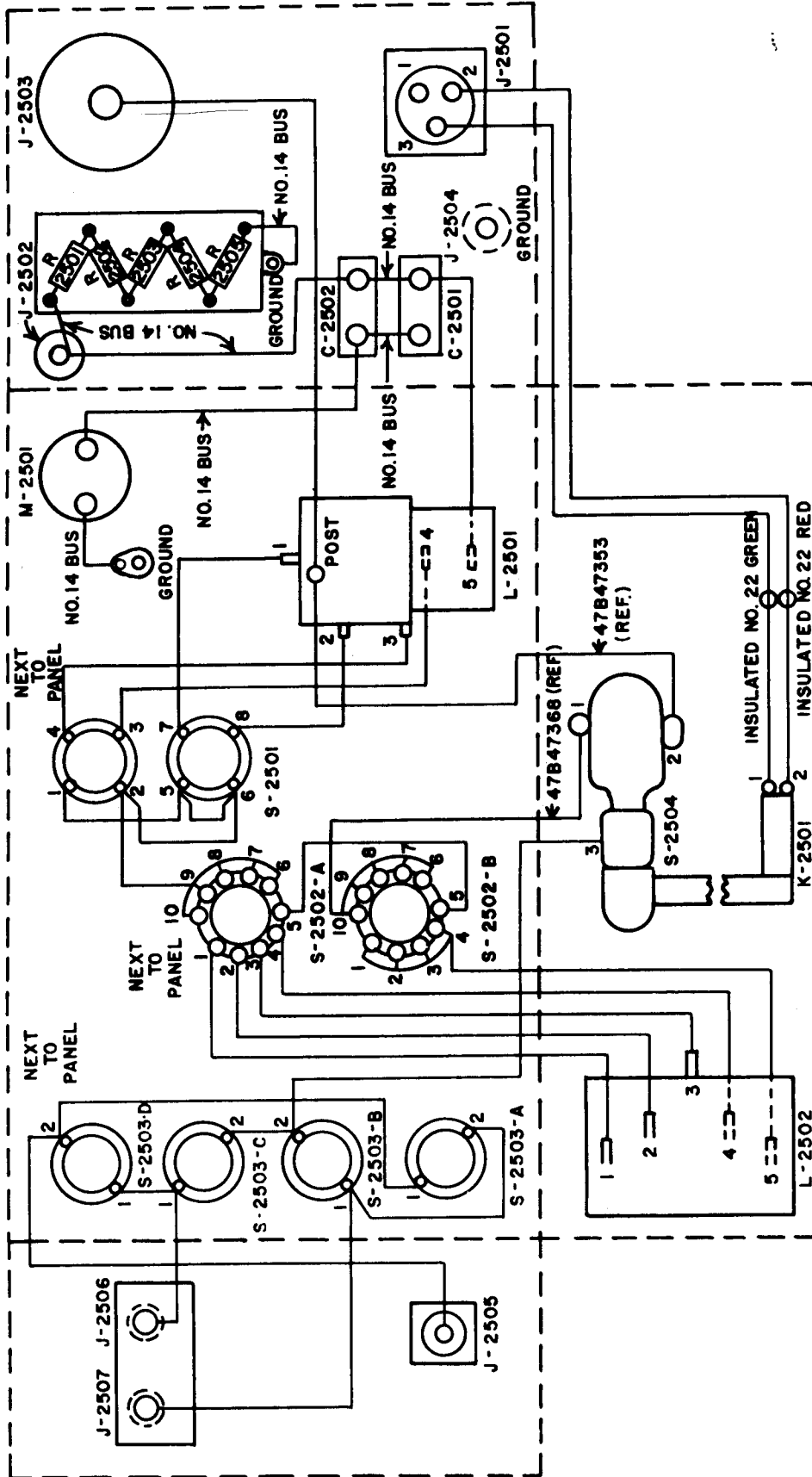

Figure 8-20A. Type CU-32/ART-13A Antenna Loading Coil, Wiring Diagram

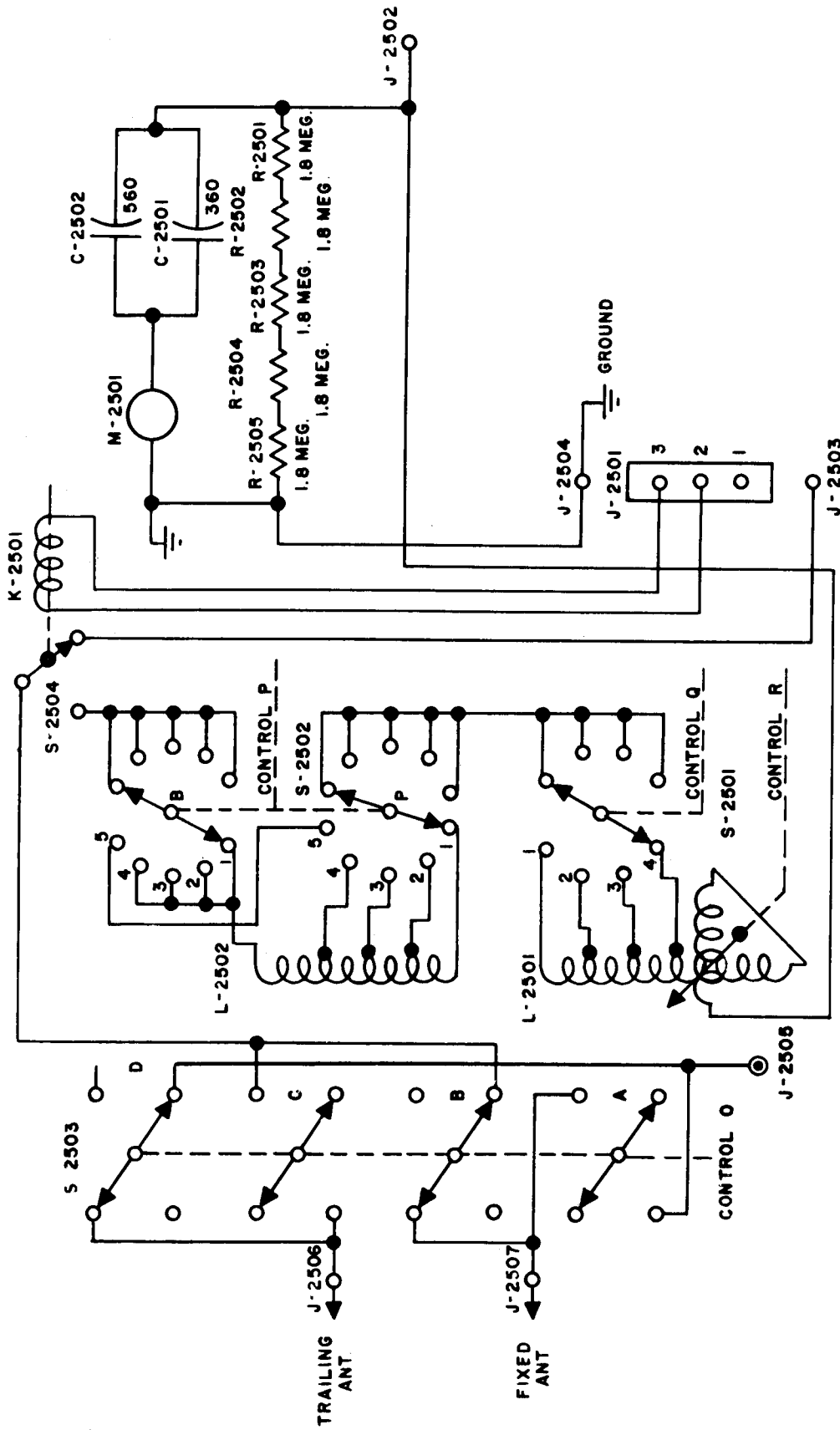

Figure 8-20B. Type CU-32/ART-13A Antenna Loading Coil, Schematic Diagram

# AN 08-30ART13-5

LEAD PREFIX	AMC. INDIC.	INSULATE VOLTAGE RATING
A	22	1000
B	20	1500
C	18	1000
D	16	1000
E	14	1000
F	12	1000
G	10	1000
H	8	1000
I	6	1000
J	4	1000
K	2	1000
L	0	1000
M	0	1000
N	0	1000
O	0	1000
P	0	1000
Q	0	1000
R	0	1000
S	0	1000
T	0	1000
U	0	1000
V	0	1000
W	0	1000
X	0	1000
Y	0	1000
Z	0	1000
AA	0	1000
BB	0	1000
CC	0	1000
DD	0	1000
EE	0	1000
FF	0	1000
GG	0	1000
HH	0	1000
II	0	1000
JJ	0	1000
KK	0	1000
LL	0	1000
MM	0	1000
NN	0	1000
OO	0	1000
PP	0	1000
QQ	0	1000
RR	0	1000
SS	0	1000
TT	0	1000
UU	0	1000
VV	0	1000
WW	0	1000
XX	0	1000
YY	0	1000
ZZ	0	1000
AAA	0	1000
BBB	0	1000
CCC	0	1000
DDD	0	1000
EEE	0	1000
FFF	0	1000
GGG	0	1000
HHH	0	1000
III	0	1000
JJJ	0	1000
KKK	0	1000
LLL	0	1000
MMM	0	1000
NNN	0	1000
OOO	0	1000
PPP	0	1000
QQQ	0	1000
RRR	0	1000
SSS	0	1000
TTT	0	1000
UUU	0	1000
VVV	0	1000
WWW	0	1000
XXX	0	1000
YYY	0	1000
ZZZ	0	1000

**NOTE 1.**  
Some connecting lines have been drawn heavy to aid in tracing connections. The width of a line has nothing to do with the type or size of wire.

**NOTE 2.**  
The connection from S106RB to R137 is grounded and R137 is not present in transmitters with serial numbers lower than 2300.

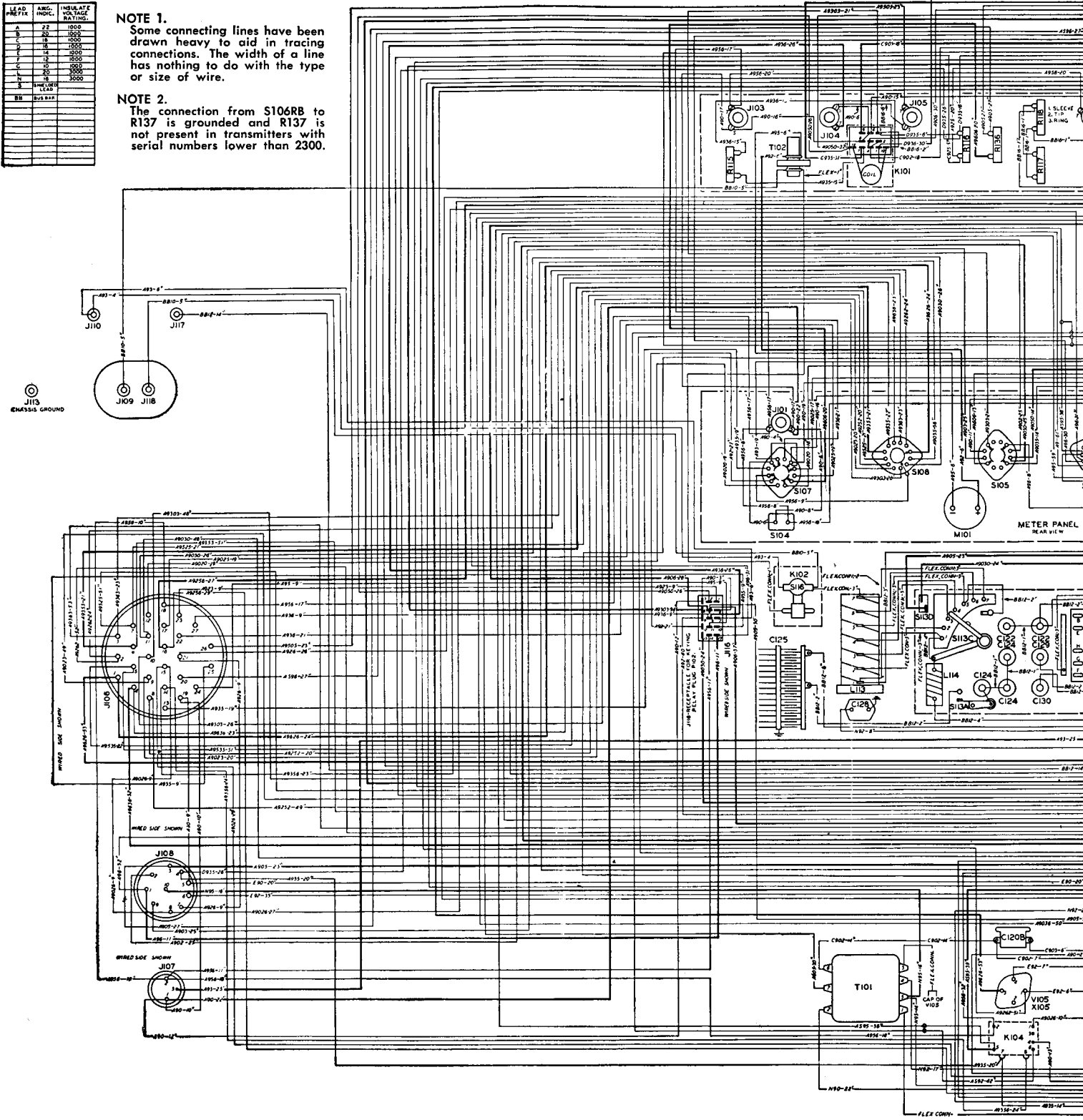



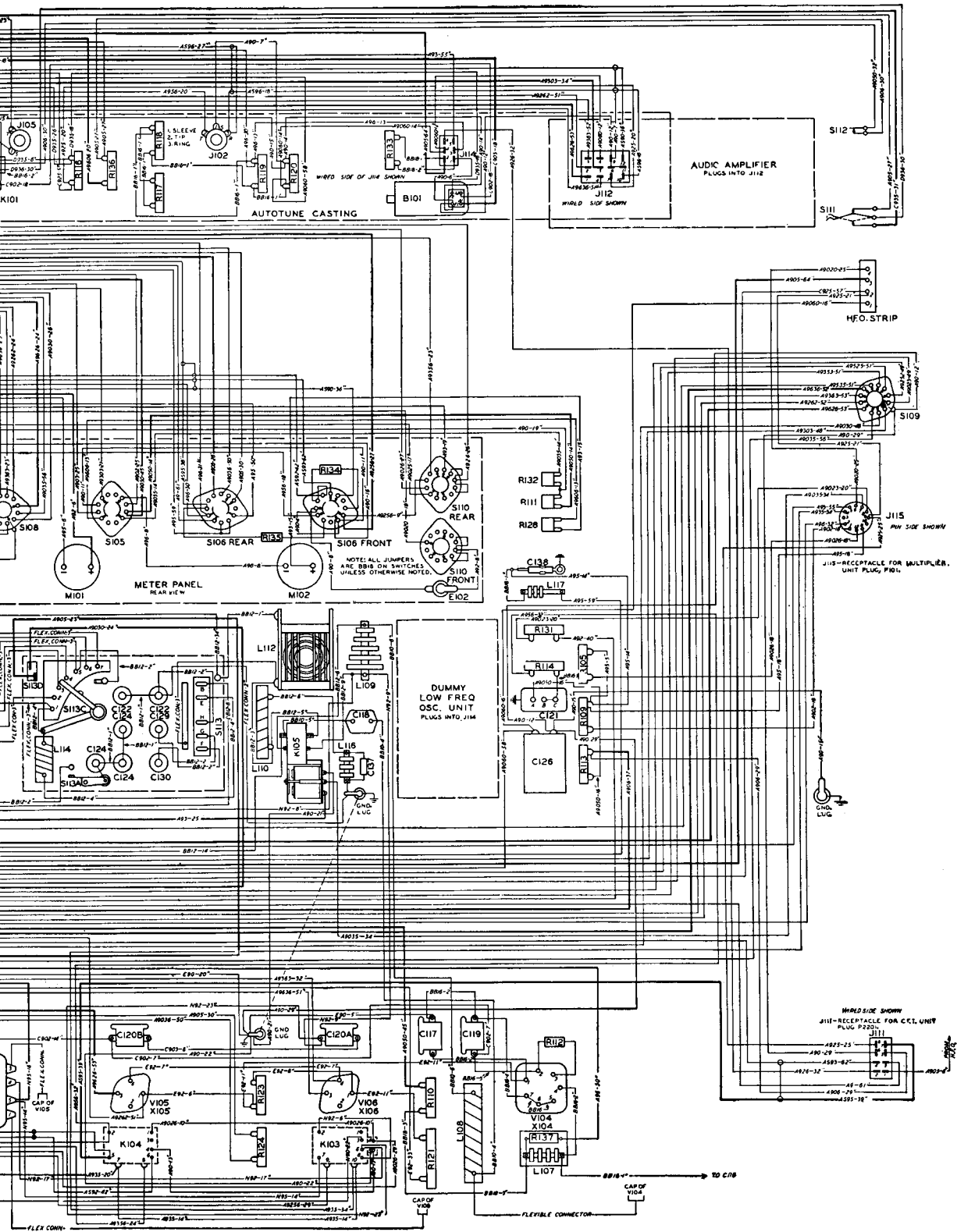

Figure 8-21. Type T-47/ART-13 Transmitter Practical Wiring Diagram—All Units Removed

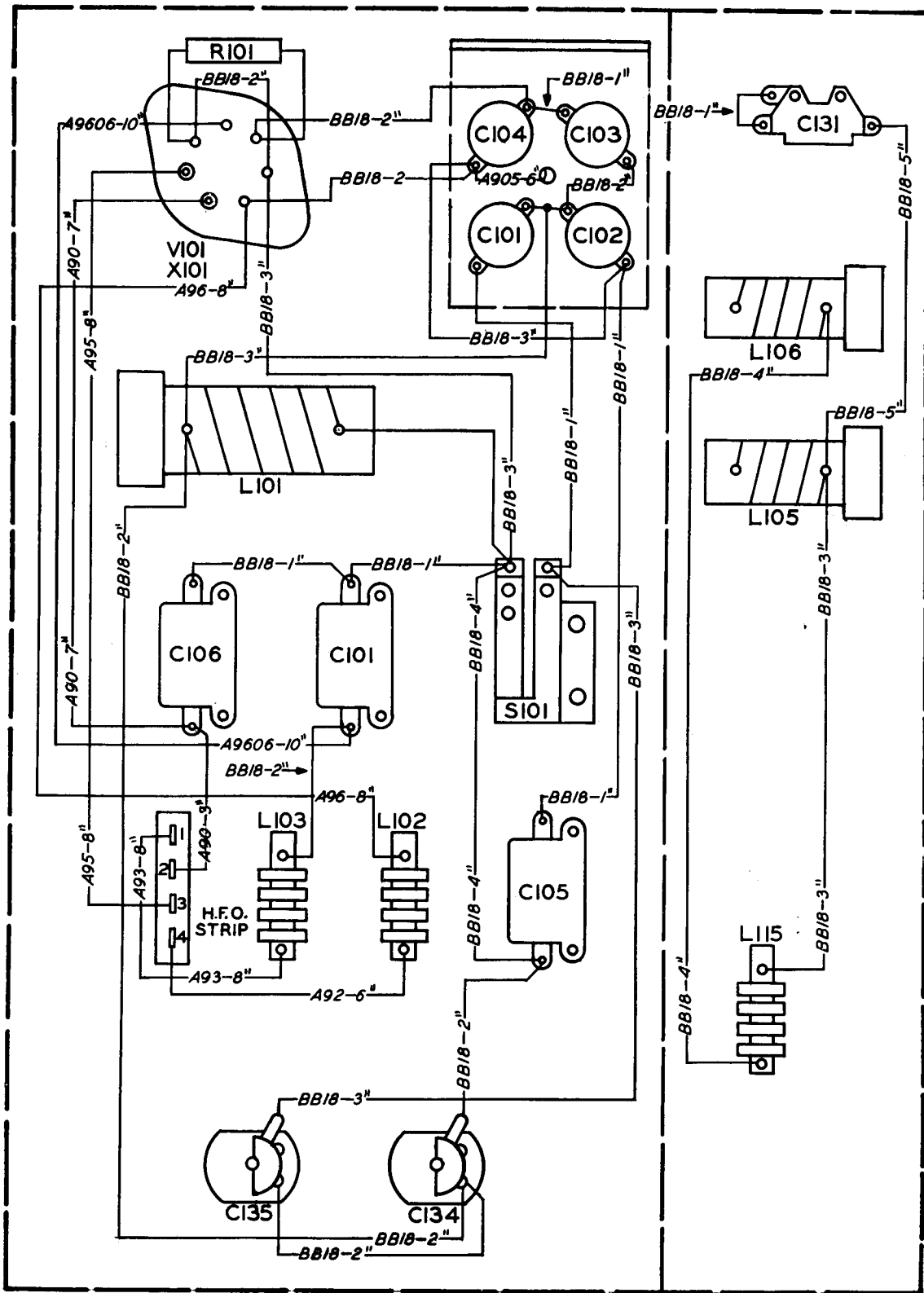
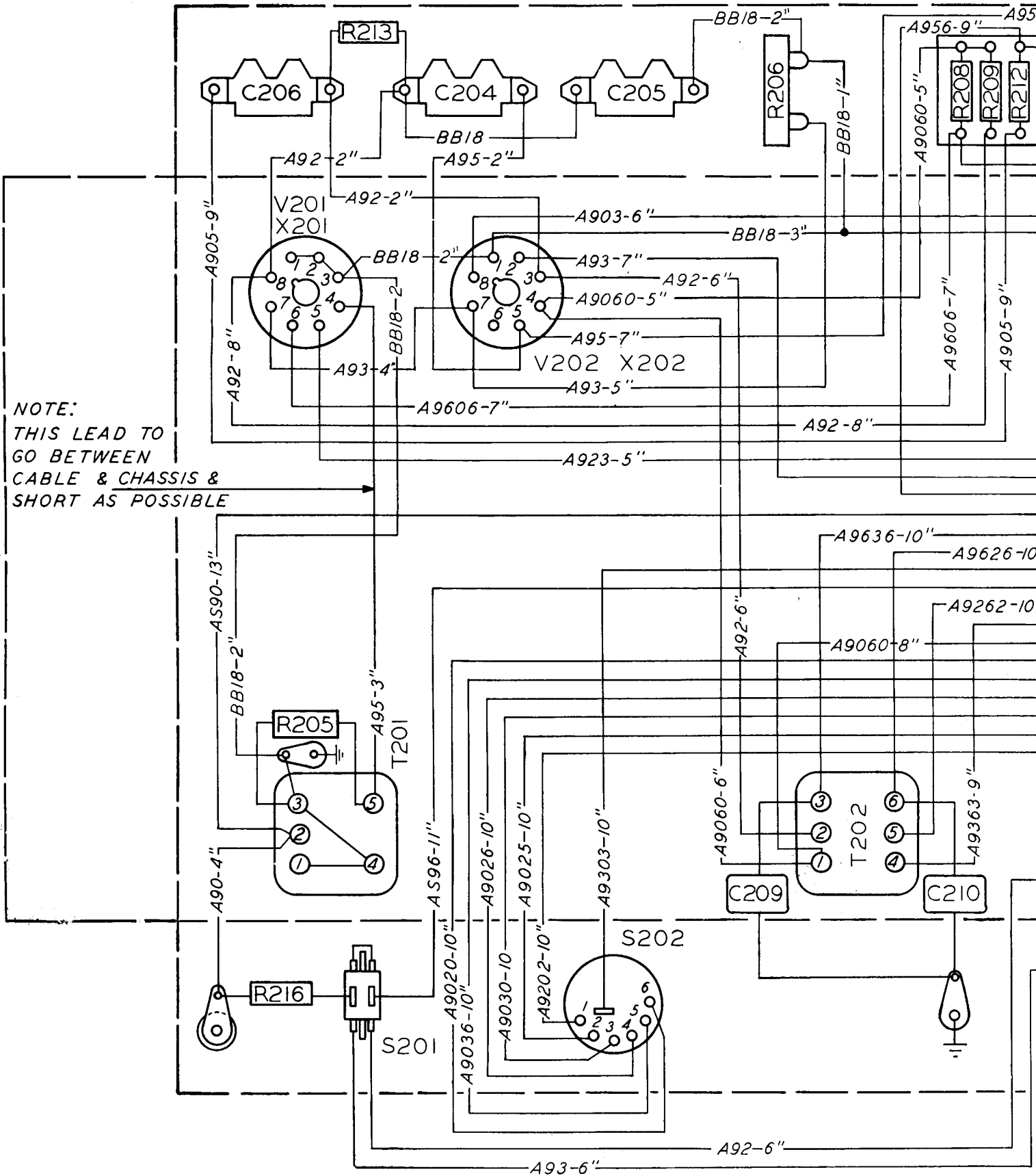

Figure 8-22. High Frequency Oscillator Practical Wiring Diagram





AN 08-30ART13-5



NOTE:  
THIS LEAD TO  
GO BETWEEN  
CABLE & CHASSIS &  
SHORT AS POSSIBLE

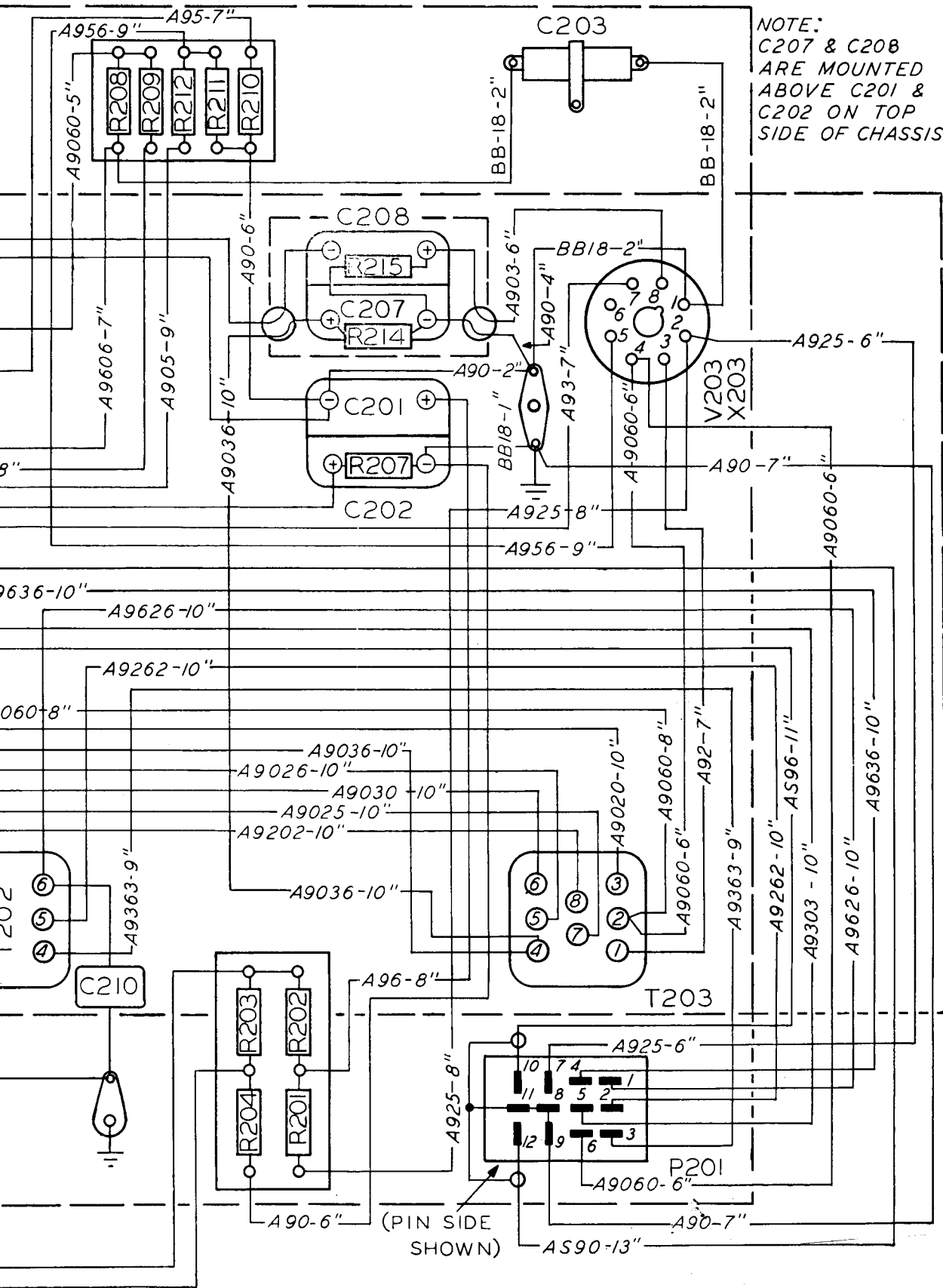
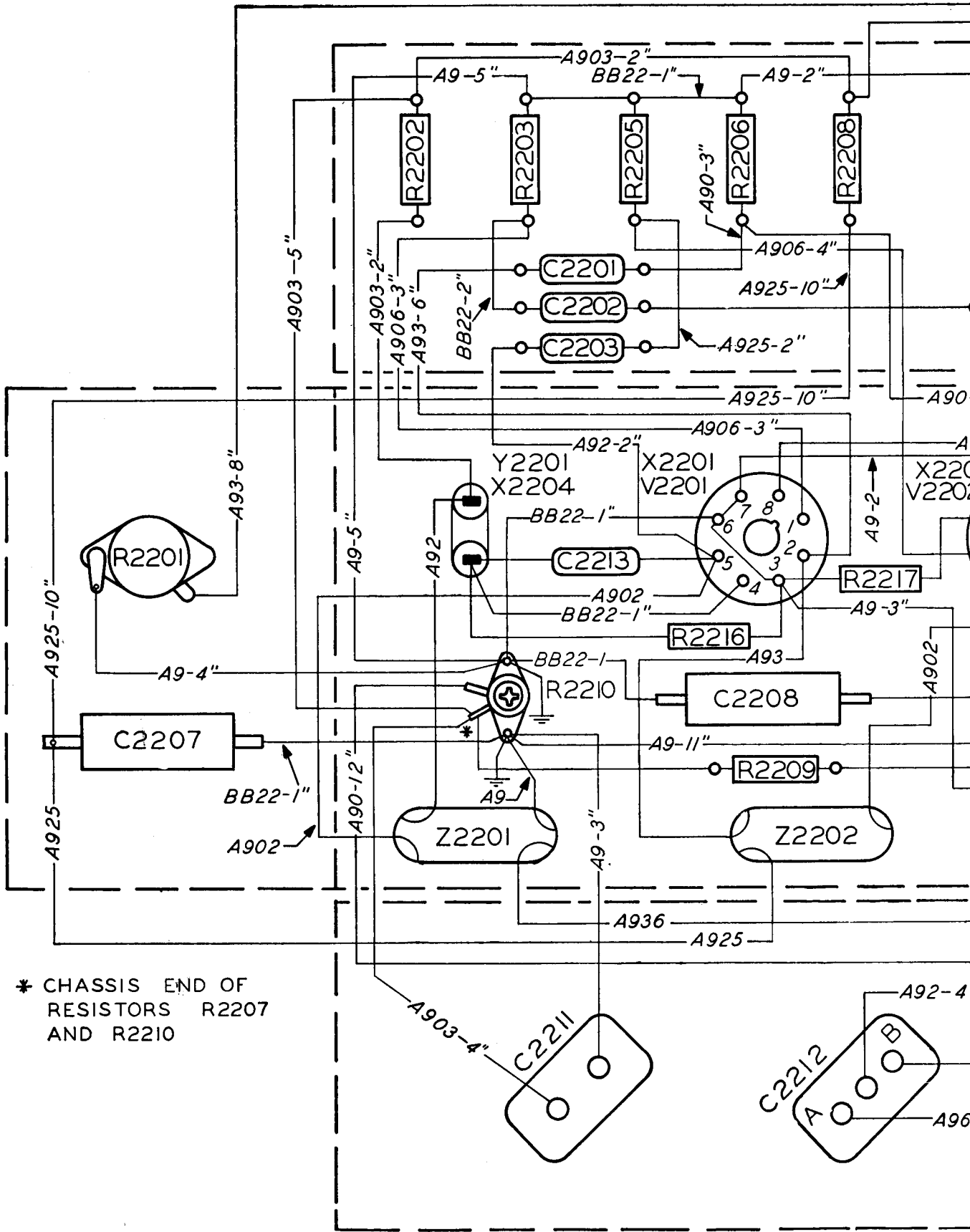

Figure 8-24. Audio Unit  
Practical Wiring Diagram



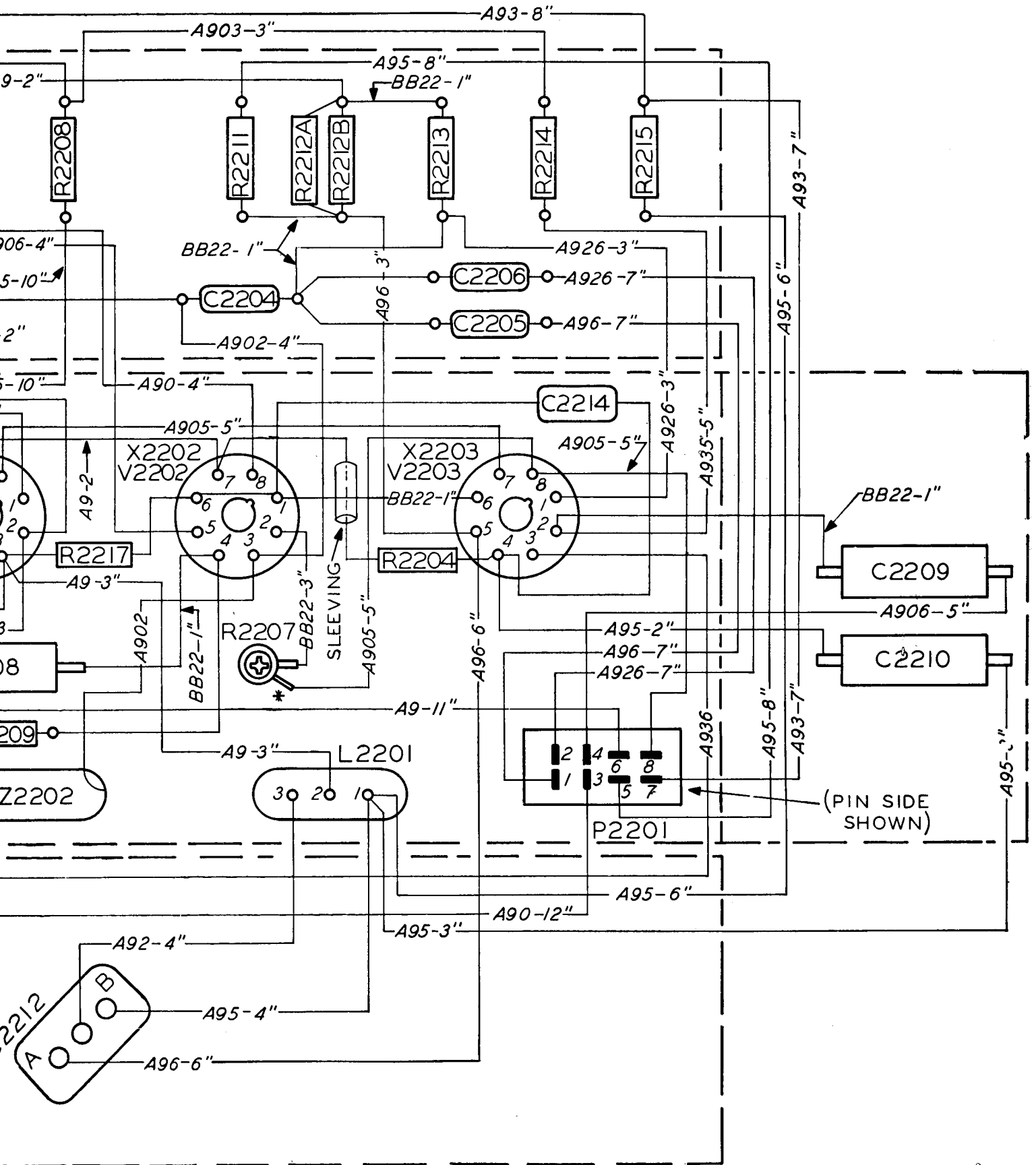

Figure 8-25. MCW-CFI Unit Practical Wiring Diagram



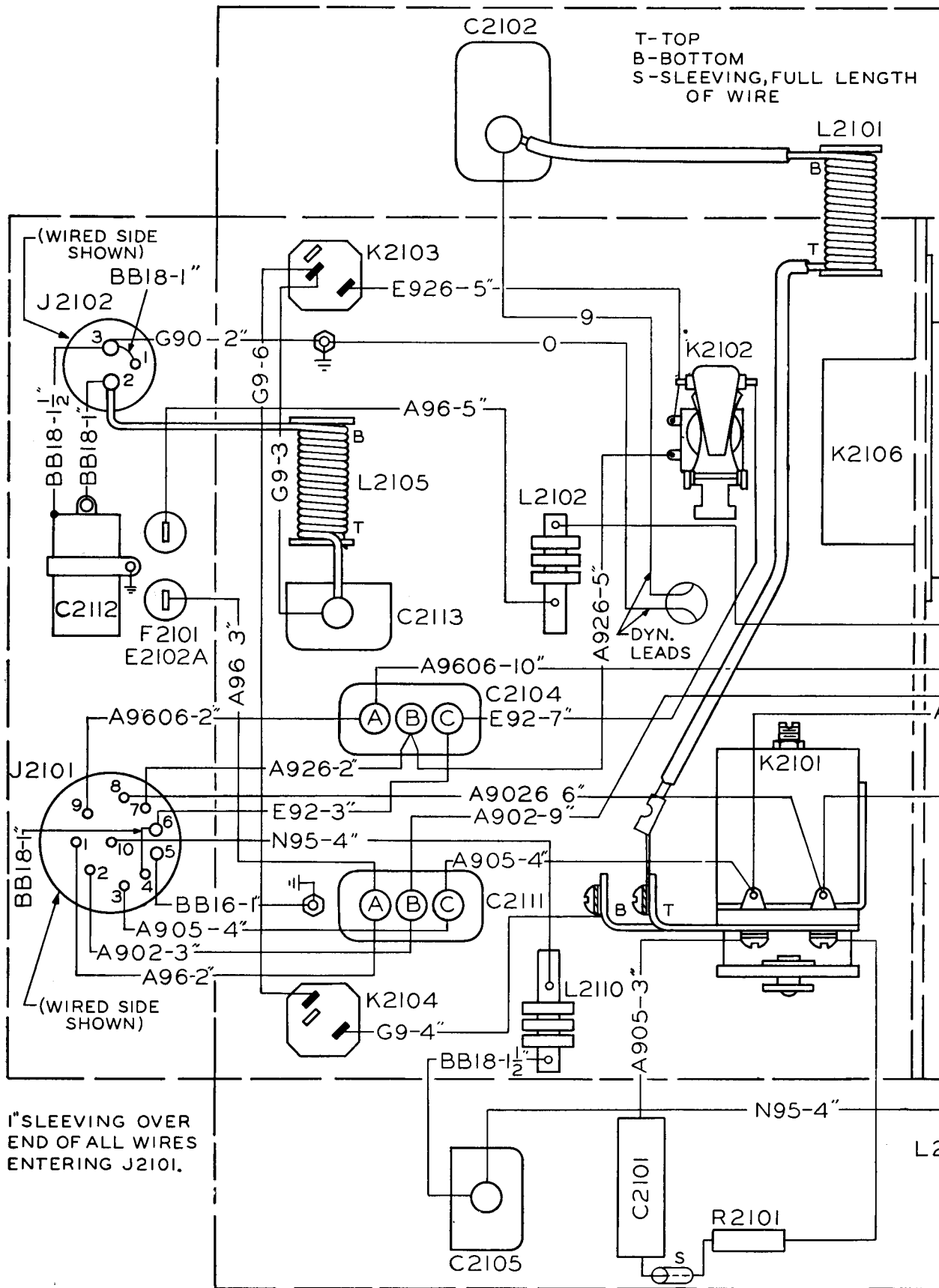

Figure 8-26. Type DY-

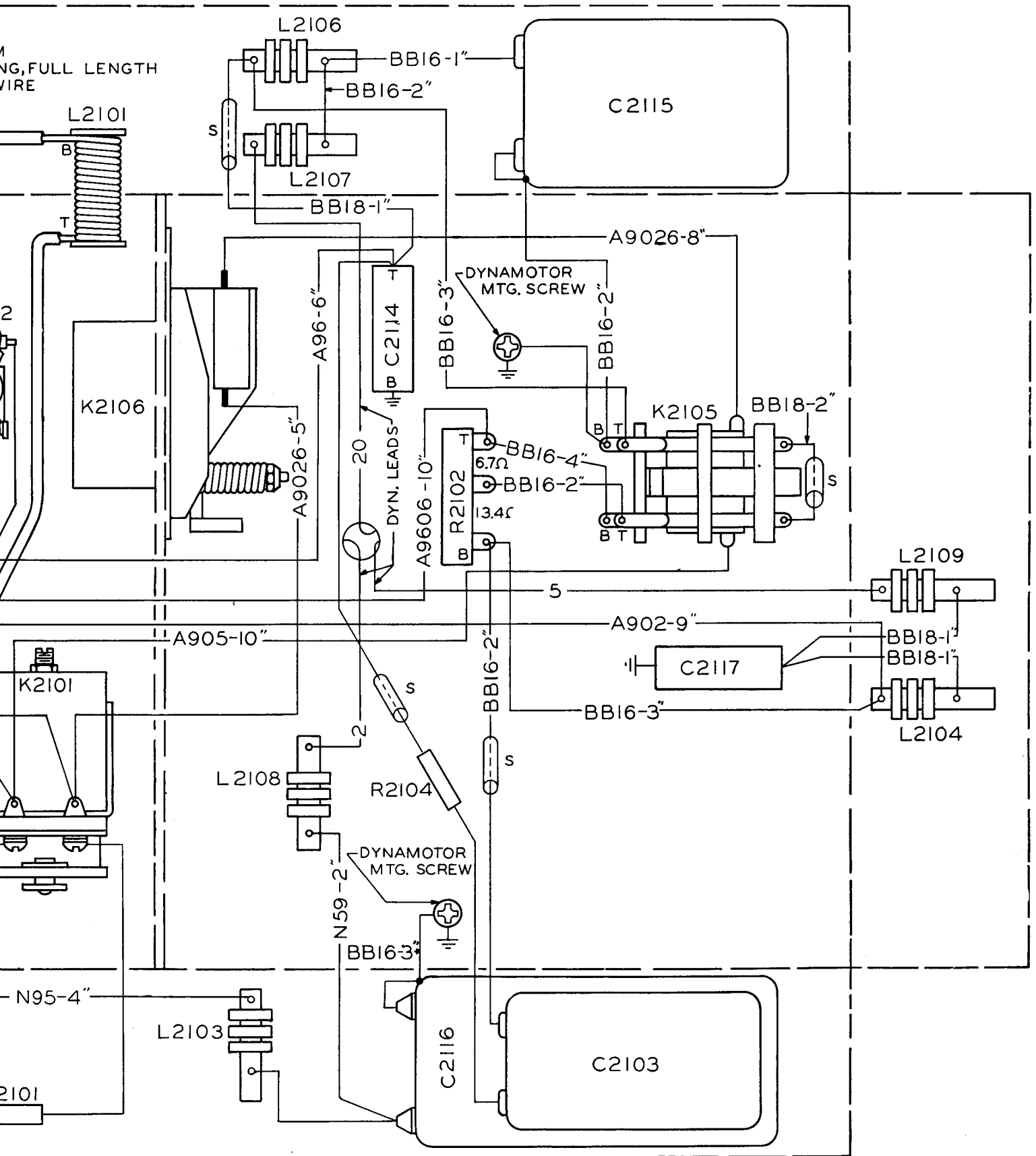

Figure 8-26. Type DY-11/ART-13, Type DY-12/ART-13 or Type DY- /ART-13 Dynamotor Power Unit Practical Wiring Diagram

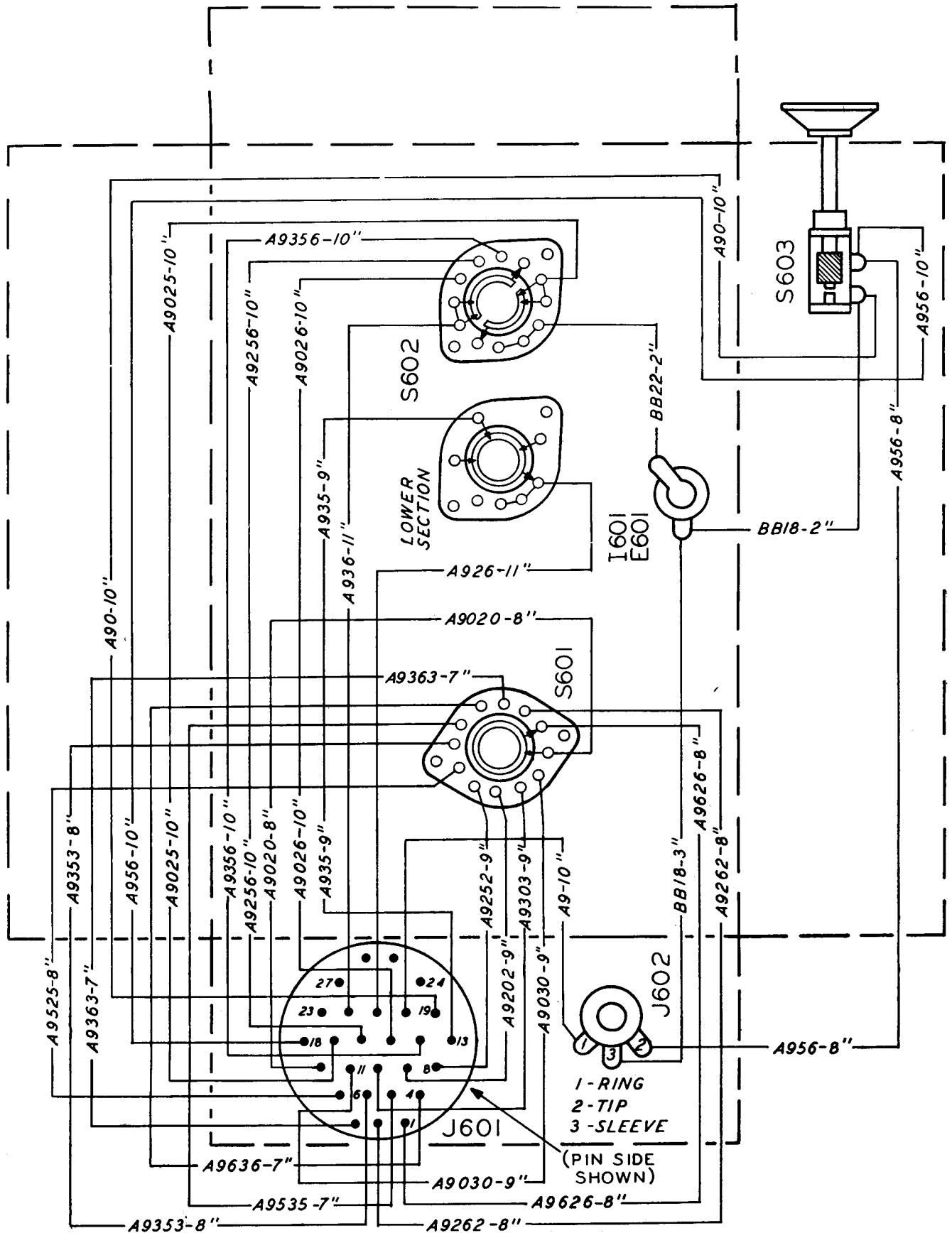

Figure 8-27. Type C-87/ART-13 Pilot's Control Unit Practical Wiring Diagram

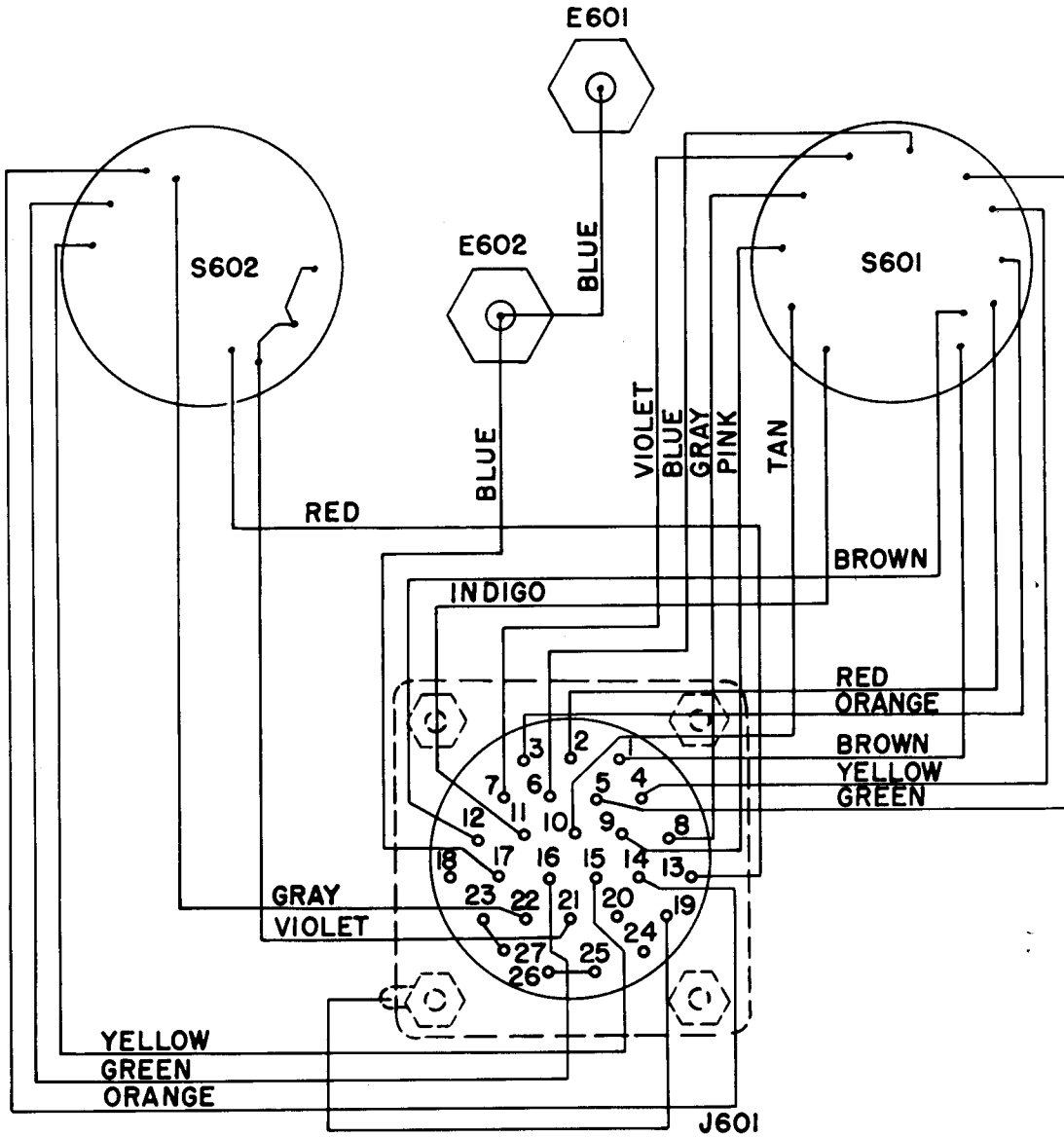
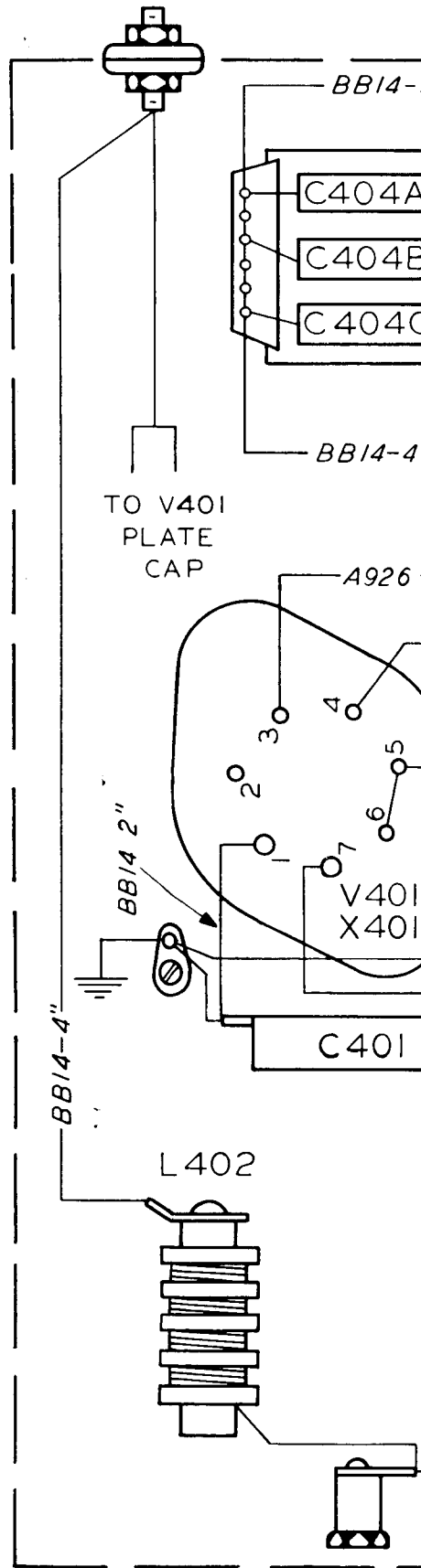
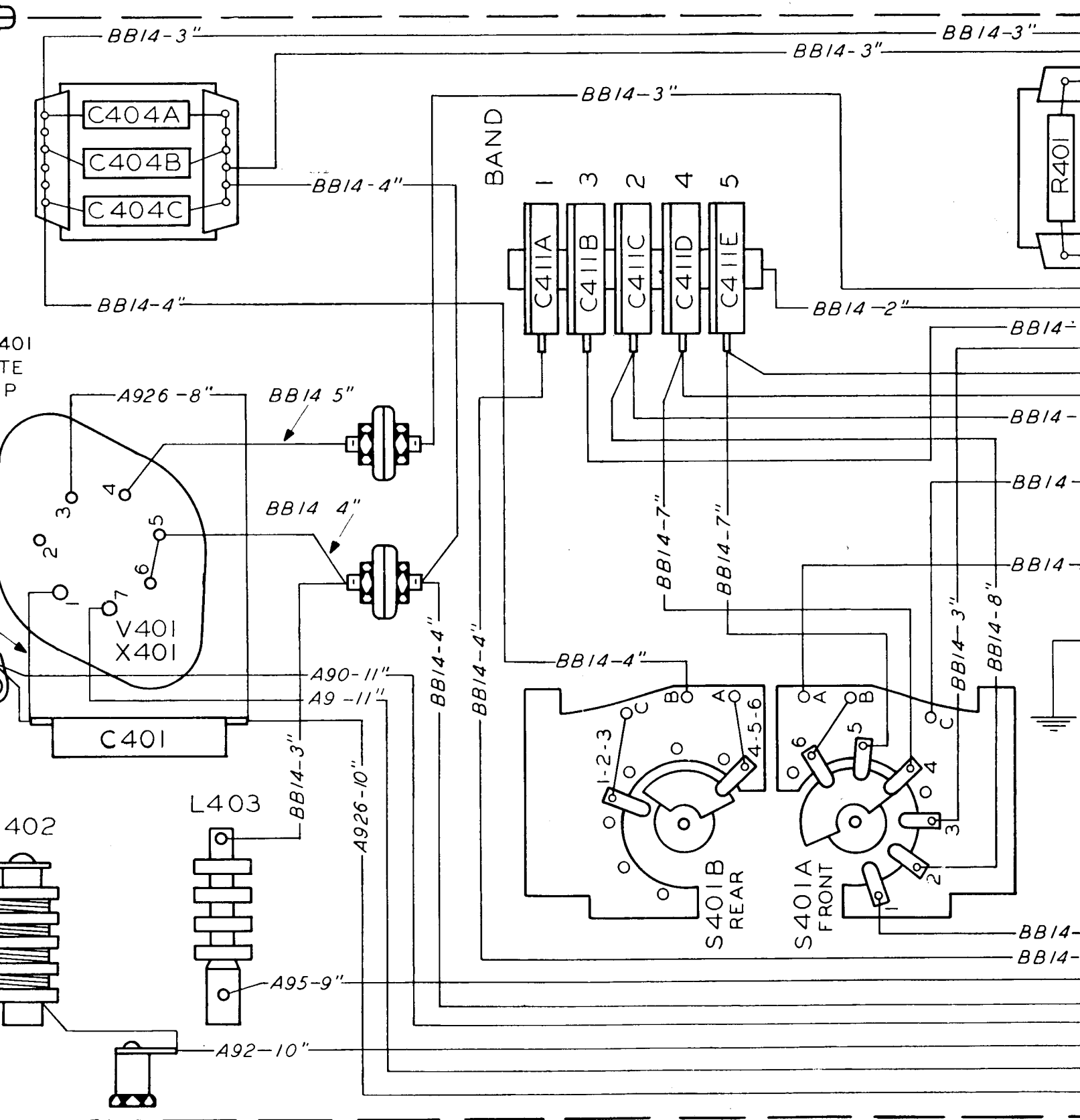

Figure 8-27A. Type C-740/ART-13 Pilot's Control Unit Practical Wiring Diagram

Revised 1 May 1953





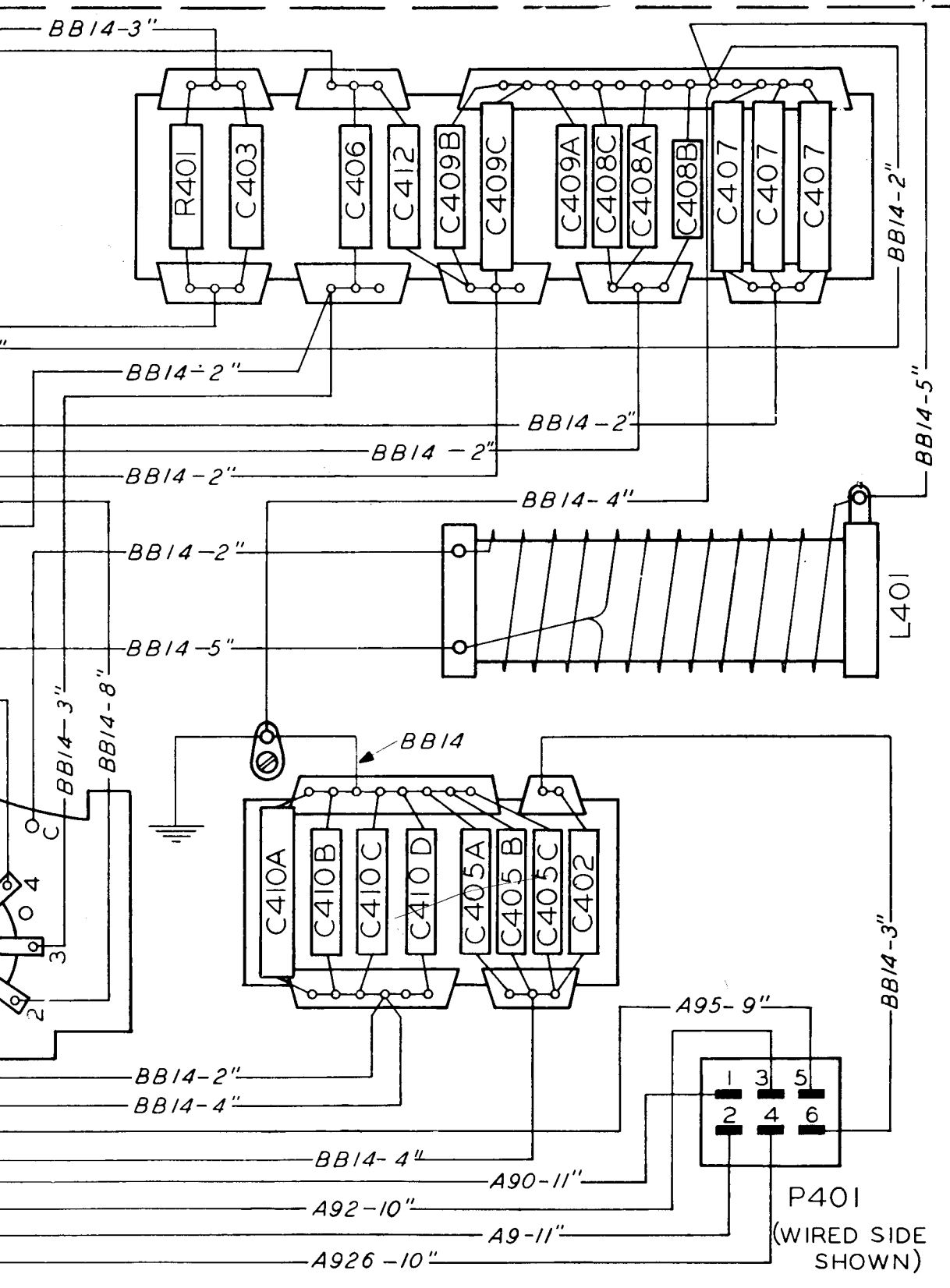
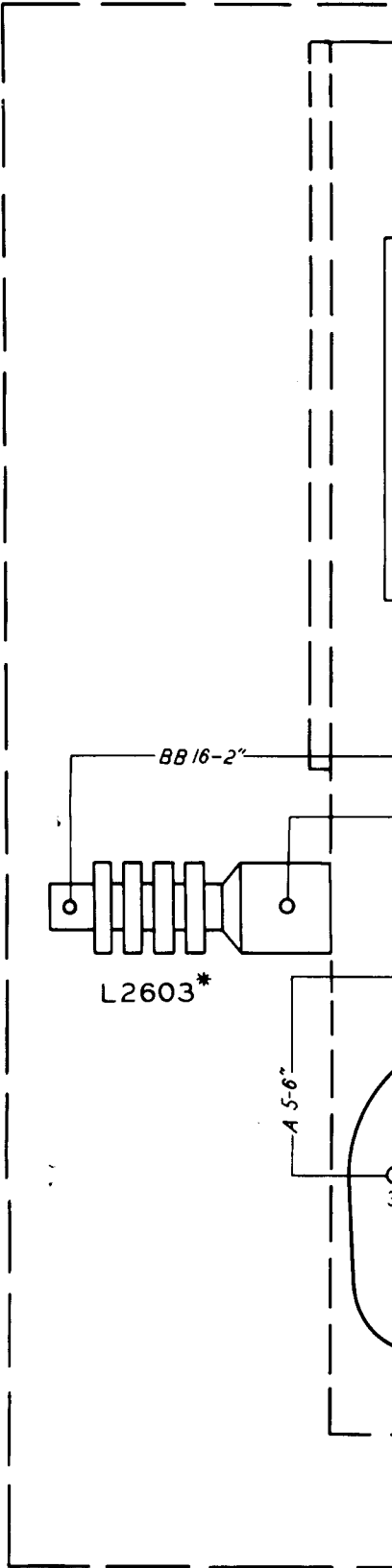

Figure 8-28. Type O-16/ART-13 Low Frequency Oscillator Practical Wiring Diagram







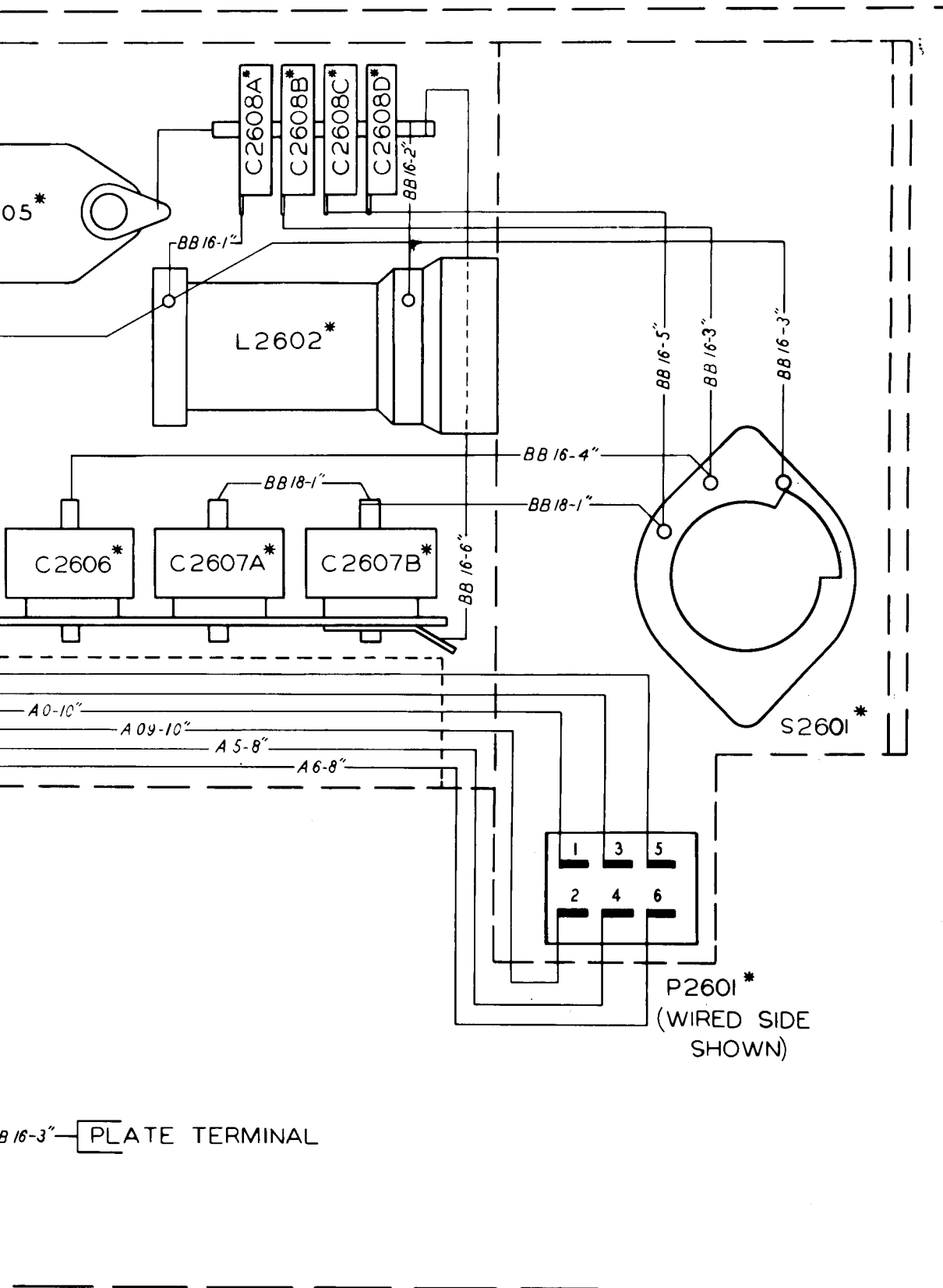
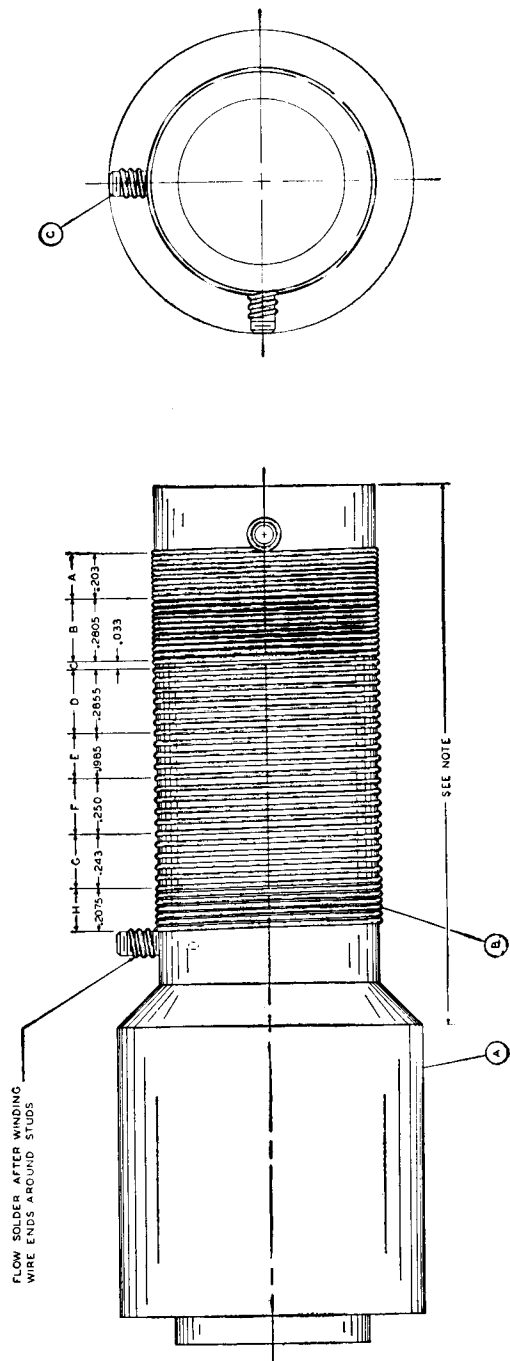

Figure 8-28A. Type O-17/ART-13A Low Frequency Oscillator Practical Wiring Diagram

ITEM	QTY	DESCRIPTION	UNIT
1	1	FORM	
2	1	WIRE	
3	1	WIRE	
4	1	WIRE	
5	1	WIRE	
6	1	WIRE	
7	1	WIRE	
8	1	WIRE	
9	1	WIRE	
10	1	WIRE	
11	1	WIRE	
12	1	WIRE	
13	1	WIRE	
14	1	WIRE	
15	1	WIRE	
16	1	WIRE	
17	1	WIRE	
18	1	WIRE	
19	1	WIRE	
20	1	WIRE	
21	1	WIRE	
22	1	WIRE	
23	1	WIRE	
24	1	WIRE	
25	1	WIRE	
26	1	WIRE	
27	1	WIRE	
28	1	WIRE	
29	1	WIRE	
30	1	WIRE	



WINDING DATA

WINDINGS	NUMBER OF TURNS	PITCH	TURNS PER INCH
A	9	.02255	44.346
B	11	.02255	39.218
C	1	.0332	30
D	6	.04758	21.017
E	4	.04962	20.154
F	3	.0500	20
G	5	.0486	20.576
H	6 1/4	.0332	30

ASSEMBLY NOTES:  
 1. CEMENT STUDS (C) INTO COL. FORM (A)  
 2. WITH SAUERHEISEN CEMENT  
 3. WIND COIL #3 PER WINDING DATA  
 4. COAT WITH POLYSTYRENE CEMENT #912  
 AFTER WINDING.

Figure 8-29. High Frequency Oscillator Grid Inductor L101

ITEM	DESCRIPTION	PART NO.	MAT'L	FIN.
2	#2-56 X 7/16 BRASS STUD	312 3390 00		
7	#24 D.E. WIRE FT	421 2440 00		
1	DOUBLER COIL FORM	507 5716 00		

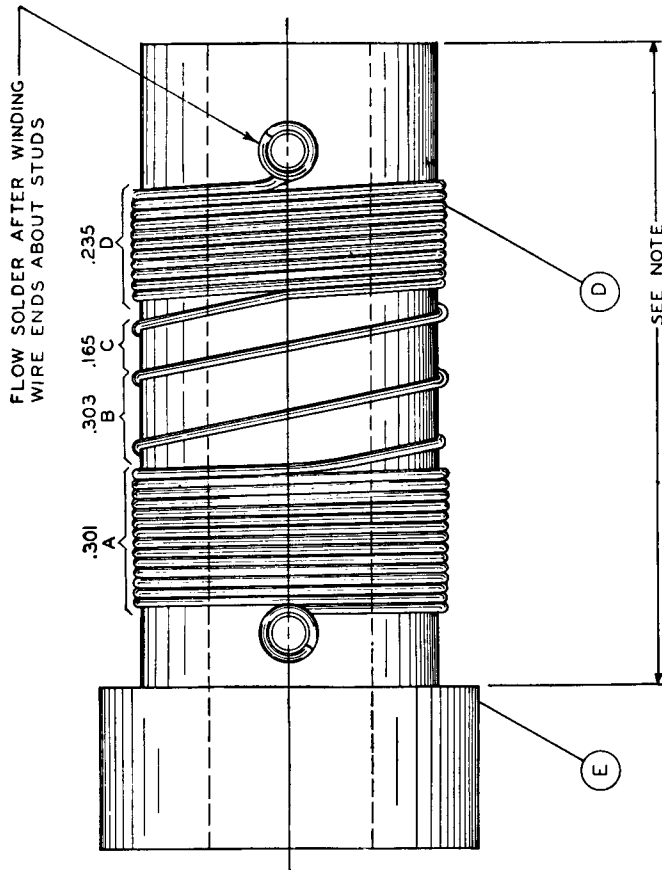
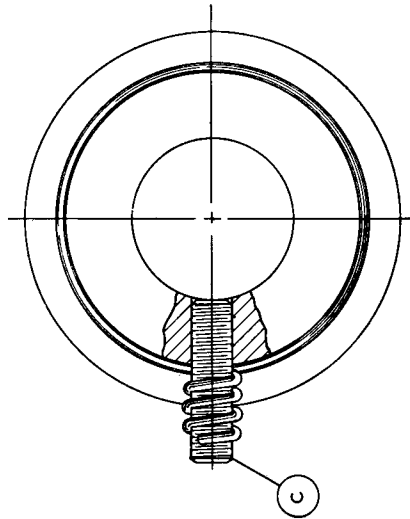

WINDING DATA

WINDING	NO. OF TURNS	PITCH	TURNS PER INCH
A	14	.0215	46.51
B	2	.1515	6.61
C	1	.165	6.06
D	11	.0215	46.51

ASSEMBLY NOTES

1. CEMENT STUDS (C) INTO COIL FORM (E) WITH DUCO WATERPROOF HOUSEHOLD CEMENT.
2. WIND COIL AS PER WINDING DATA.
3. APPLY WITH BRUSH OR SPRAY GUN ONE COAT OF #1202 CLEAR GLYPTAL CEMENT AFTER WINDING.

Figure 8-30. First Multiplier Plate Inductor L105

ITEM	DESCRIPTION	PART NO.	MAT'L	FIN.
1	COIL FORM	507 5717 00		
2	#2-56 x 1/16 BRASS STUD	312 3390 00		
3	#24 DE. WIRE, F.T.	421 2440 00		

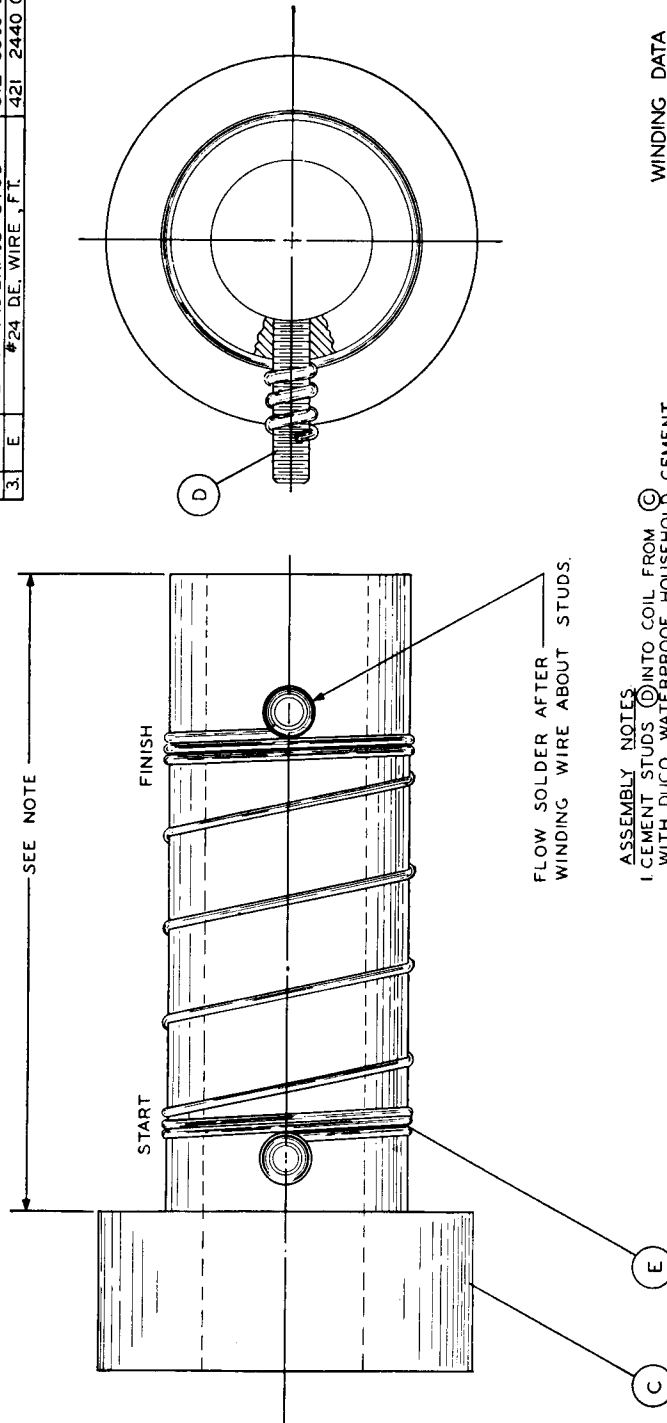

- ASSEMBLY NOTES**
1. CEMENT STUDS (D) INTO COIL FROM (C) WITH DUCO WATERPROOF HOUSEHOLD CEMENT.
  2. WIND COIL AS PER WINDING DATA
  3. APPLY WITH BRUSH OR SPRAY GUN ONE COAT OF #1202 CLEAR GLYPTAL CEMENT AFTER WINDING.

**WINDING DATA**

START	URNS	PITCH	TOTAL
START	2 - 3/4	.022	0605
	1/4	.218	.115
	1/2	.252	.241
	1/2	.178	.330
	1/2	.170	.415
	1/2	.168	.499
	1/2	.212	.605
	1/2	.174	.692
	1/4	.188	.739
	1/2	.230	.854
FINISH	2 - 1/4	.023	.906

Figure 8-31. Second Multiplier Plate Inductor L106

AN 08-30ART13-5

IT.	DESCRIPTION	PART NO.	MAT'L	FIN.
1 A	COIL FORM	507 5739 10		
X B	#27 CHROME OXIDE WIRE 3 1/2 FT.L.	421 2730 00		
2 C	#2-56 X 3/8 FILL. HD. SCR.	321 0022 00		
1 D	#2-56 HEX. NUTS	313 0006 00		
1 X	ASSEMBLY PER QUANT. "A."	571 1448 10		
1 E	SOLDERING SLEEVE	507 6842 00		

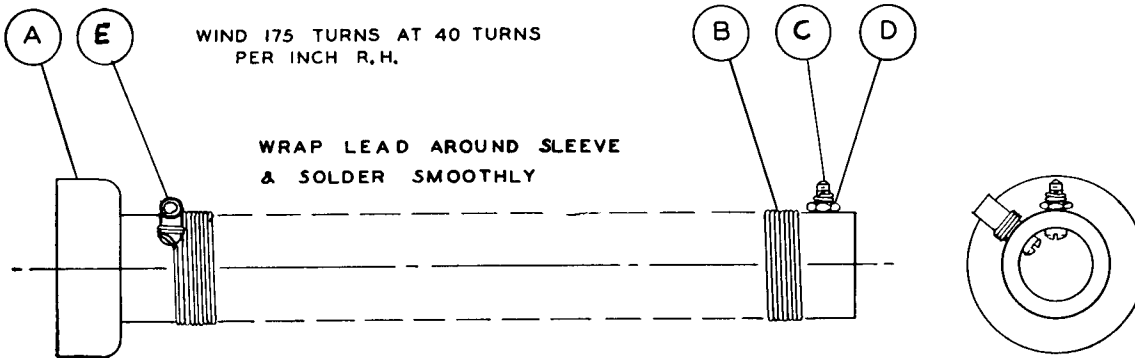

GLUE ITEMS C INTO A WITH SOUEREISEN.  
SOLDER ENDS OF WIRE TO ITEM C.

Figure 8-32. Power Amplifier Plate Feed Choke L108

IT.	DESCRIPTION	PART NO.	MAT'L	FIN.
2 A	CLAMP	139 4600 00		
2 B	.087 x .167 EYELETS	307 2800 00		
1 C	40 FEET #35 SSE. COPPER WIRE	421 3530 00		
1 D	COIL FORM	507 5742 00		
1 X	ASS'Y OF PARTS PER GROUP A.	571 2103 10		

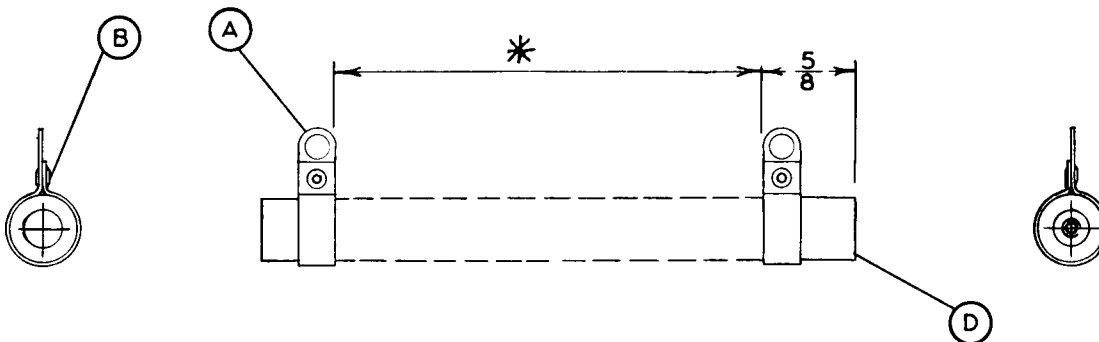

CLOSE WIND \* TURNS ITEM (C)  
FOR 190MH ± 10MH INDUCTANCE  
SOLDER ENDS TO ITEM (B)  
\* APPROXIMATELY 340 TURNS

Figure 8-33. Output Network Static Drain Choke L110

ITEM	DESCRIPTION	PART NO.	MAT'L	FIN.
1	A ROTOR COIL 5 FT. WIRE	421 0006 00	NOTE	
2	B ROTOR MTG. BAR # 2	507 6092 00		
2	C ROTOR MTG. BAR # 1	507 6093 00		
2	D ROTOR ATTACHMENT PLATE	507 6098 00		
4	E 6-32 X 5/16 PH. BRASS SCREW	343 0112 00		
4	F #6 PHOS. BR. INT. SHAKE WASHER	373 3020 00		
1	X ASS'Y. OF PARTS PER. QUANT. A	571 1246 20		

COIL #10 (100) MEDIUM HARD DRAWN  
SILVER PLATED COPPER WIRE

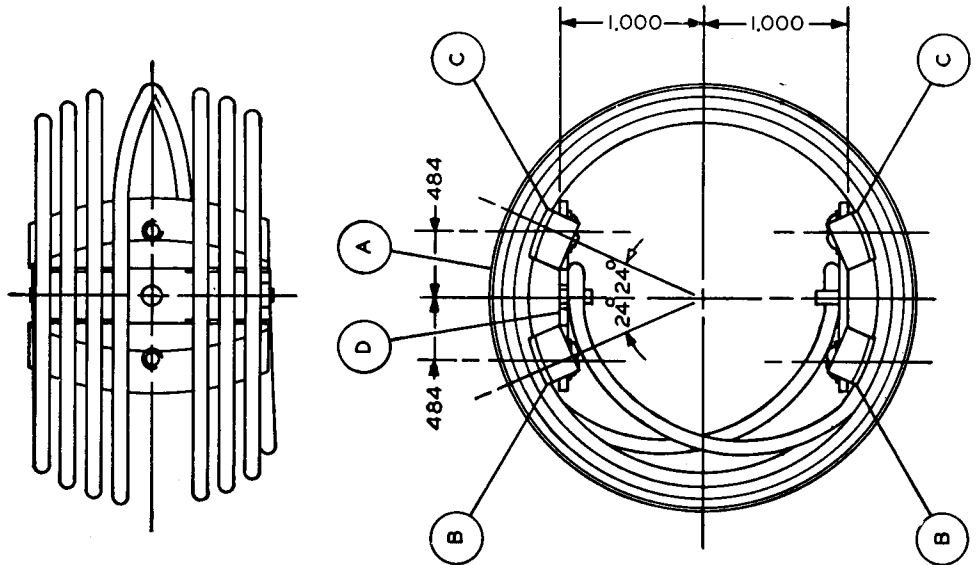

Figure 8-34. Power Amplifier Plate Inductor-Rotor for L112

ITEM	DESCRIPTION	PART NO.	MAT'L	FIN.
1	A STATOR COIL SFT. OF WIRE	421 000600	NOTE	
2	B MOUNTING BAR #2	507 6100 00		
2	C MOUNTING BAR #1	507 6099 00		
1	D ROTOR BEARING BAR #1	507 6090 00		
1	E ROTOR BEARING BAR #2	507 6091 00		
	F			
4	G 6-32 X 5/16 PH. BIND. HD. SCREW, BRASS	343 0112 00		
4	H #6 PHOS. BR. INT. SHAKE WASHER	373 3020 00		
1	X ASSY OF PARTS PER QT. "A"	571 1245 20		

COIL: #10 (.100) MEDIUM HARD DRAWN SILVER PLATED COPPER WIRE.

NOTE: ENDS OF COILS TO BE ROUND AND FREE FROM SHARP EDGES.

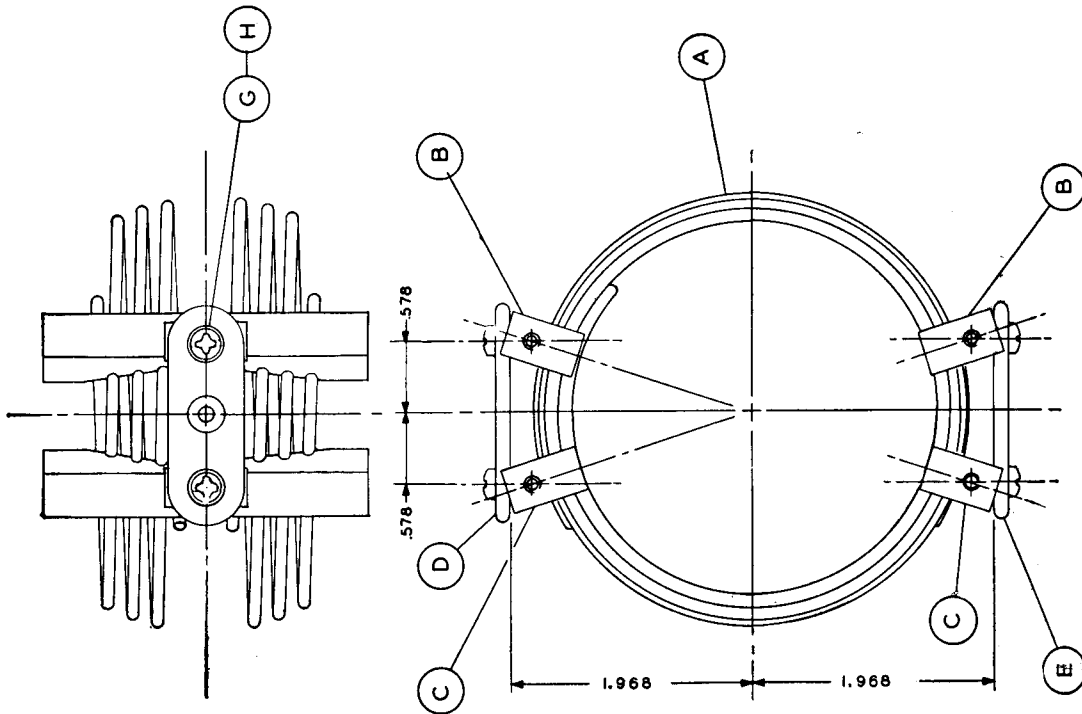
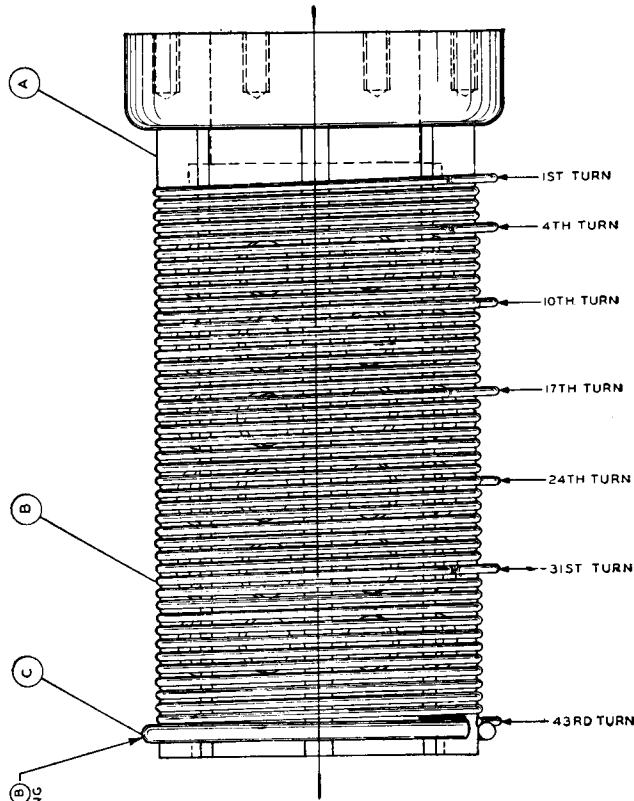

Figure 8-35. Power Amplifier Plate Inductor-Stator for L112



AN 08-30ART13-5

ITEM	PART NO.	DESCRIPTION	MAT'L	QTY.
1	A 571 1100 20	COIL FORM		
1	B 421 1421 00	28 FT. 14 LEAD COVERED COPPER WIRE		
1	C 507 7350 00	CORONA RING		



SOLDER ITEM (C) TO ITEM (B) AT 4 POSITIONS INCLUDING BOTH ENDS, USE HARD SOLDER 90-10

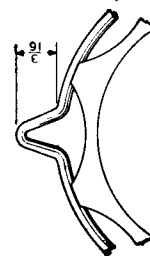
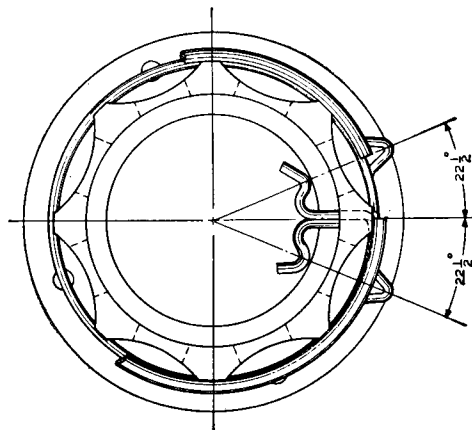

ENLARGED DETAIL OF TAP LOOPS

WINDING DATA

WIRE	GAUGE	PART NO.	APPROXIMATE NUMBER OF TURNS	TYPE OF WINDING	L.	DIST. C.	Q.	FREQ.	CAP.
LEAD COVERED COPPER WIRE	14	421 1421 00	43	SINGLE LAYER	42μH		325	2.0M C.	150μF D <sub>1</sub>

Figure 8-36. Antenna Loading Inductor L113

IT.	DESCRIPTION	PART NO.	MAT'L	FIN.
1 A	COIL FORM	5075922 00		
4. B	#16 LEADED COPPER WIRE	421 1621 00		

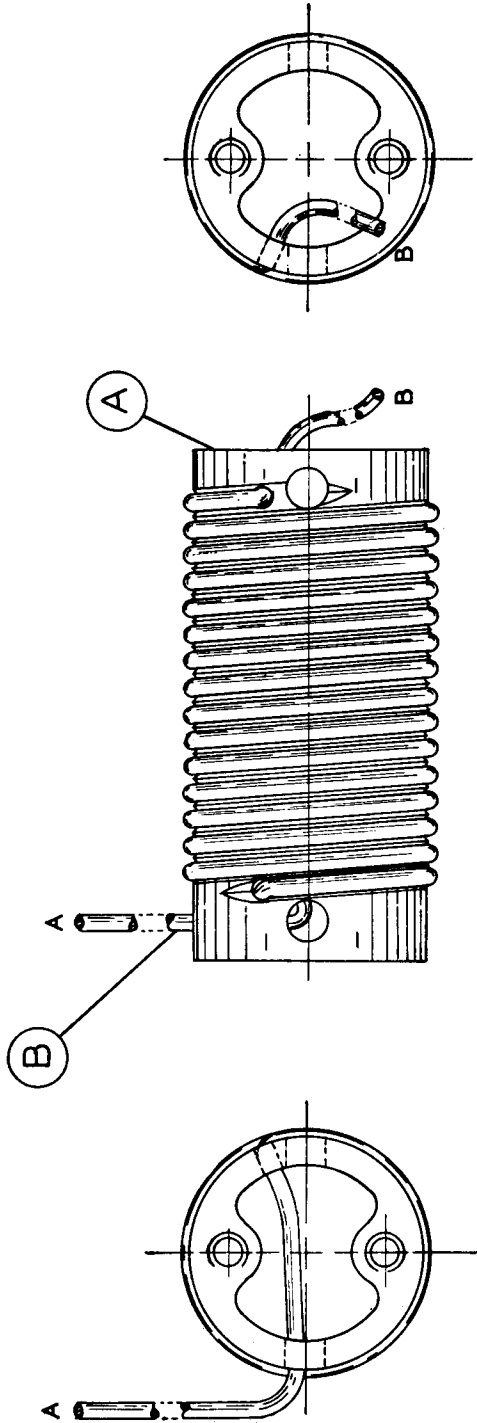

END 'A' IS THREE INCHES LONG  
 END 'B' IS ONE INCH LONG  
 WINDING & TEST DATA (WITH Q METER)

WIRE	GAUGE	PART NUMBER	NO. OF TURNS	TYPE OF WINDING	L. (MIN)	Q.	FREQ. (MHz)	CAP. (pF)
LEADED COPPER WIRE	16	421/1621/00	15	SINGLE LAYER	2.1 ± 5%	270 MIN.	18.	37.

Figure 8-37. Power Amplifier Tank Padding Inductor L114

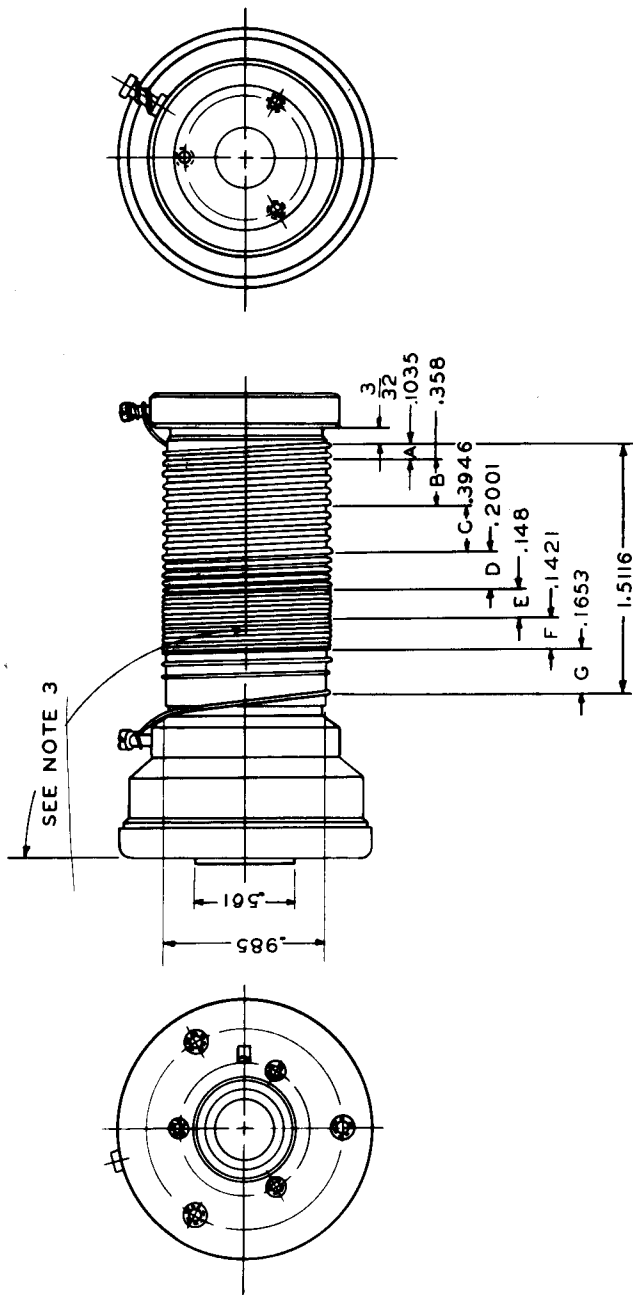

WINDING DATA  
 MATERIAL - NO. 26 GAUGE HEAVY ENAMELED COPPER  
 NO. OF TURNS - 50  
 TYPE OF WINDING - SINGLE LAYER - SPACED

WINDING	PER SECTION	PITCH	TURNS PER INCH
A	2.66	.0389	25.7
B	10.2	.0351	28.5
C	10.9	.0362 +	27.6
D	8.1	.0247	40.5
E	8.	.0185	54
F	7.25	.0196	51
G	2.89	.0572	17.5

ASSEMBLY NOTES:  
 1-AFTER WINDING APPLY ONE COAT OF AMERICAN PHENOLIC CORPORATION'S POLYSTYRENE LIQUID #912 OR EQUIVALENT. CEMENT SECURELY THE INSIDE OF THE CAP AND THE THREADS OF THE STUDS AT ASSEMBLY.  
 2-AFTER ASSEMBLY, THIS SURFACE MUST BE PERPENDICULAR TO HORIZONTAL AXIS WITHIN 20 MINUTES.  
 3-561 DIAMETER TO BE CONCENTRIC TO .985 DIAMETER WITHIN .004 OF FULL INDICATOR READING.

Figure 8-38A. Low Frequency Oscillator Grid Inductor L2602\*

ITEM	PART NO.	DESCRIPTION	MATL.	FIN.
1	A	571 1866 20 L.F. OSCILLATOR COIL FORM		
3	B	312 3360 00 2-56 X 5/8 STUD		
2	C	014 4000 00 TAPE 1/4 X .005 FT.		
3	D	422 5100 00 48-38 LITZ WIRE, FT.		

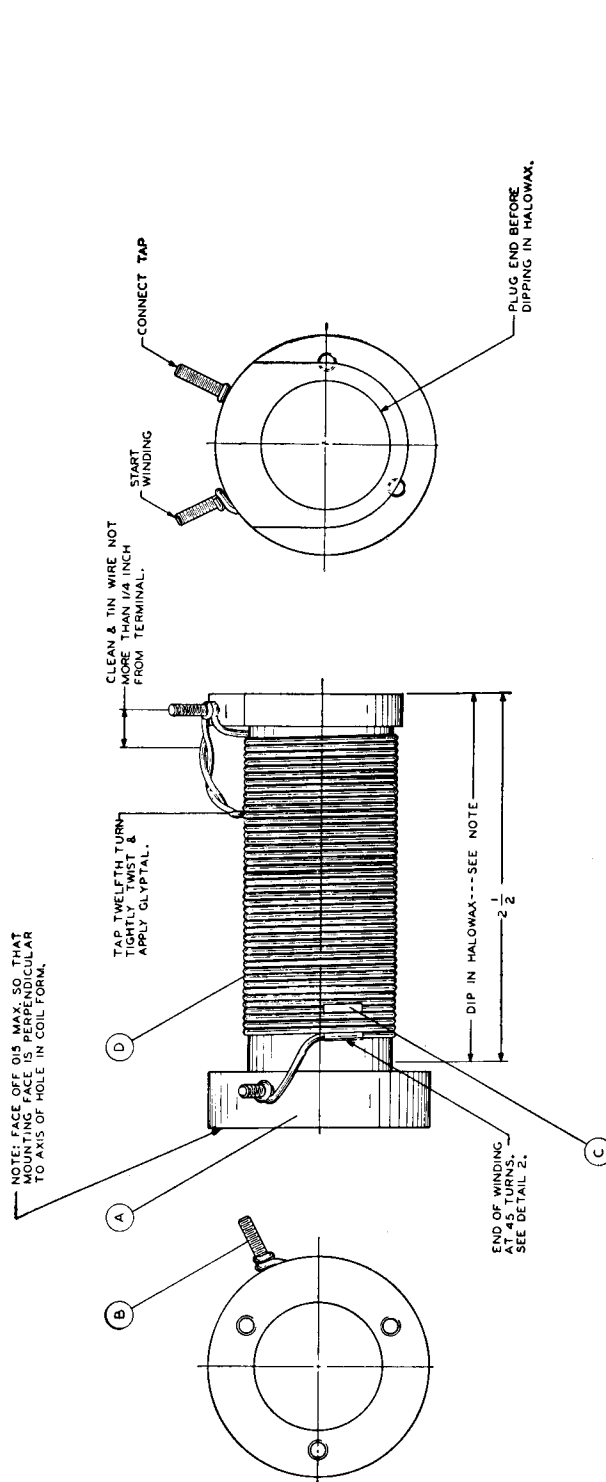

ASSEMBLY NOTES:

1. IMPREGNATE WITH CERESIN AA OR EQUIVALENT AT TEMPERATURE OF 121-126°C (250-260°F) UNTIL AIR BUBBLES CEASE. LET COOL, THEN FLASH DIP IN HALOWAX, NO.2141, AT TEMPERATURE OF 176-182°C (350-360°F).

- NOTE: THE COAT OF WAX MUST BE FREE FROM BUBBLES & BLOW HOLES & NOT MORE THAN 1/32 IN. THICK.
2. CEMENT ITEM (B) TO ITEM (A) WITH DUCO CEMENT 4N457



DETAIL NO. 1  
TAPE AT START OF WINDING.

DETAIL NO. 2  
TAPE AT END OF WINDING.

WINDING DATA NOTE: INDUCTANCE AT 1000.C.P.S. 200MH.

WIRE	GUAGE	PART NO	NO. OF TURNS	TYPE OF WINDING	L <sub>s</sub>	DIST. C.	Q.	FREQ.	CAP.
48-38 LITZ	19	422 5100 00	45	SINGLE LAYER	18956 μH ± 1/2	3166MMF. ± 8%	104	2000KC.	320MMF.

Figure 8-38. Low Frequency Oscillator Grid Inductor L401

AN 08-30ART13-5

ITEM	DESCRIPTION	PART NO.	MAT'L	FIN.
1	A VARIOMETER ROTOR	571 0966 30		
1	B 30FT. LITZ WIRE	422 5100 00		
2	C 6-40x 3/16 BRASS FIL.HD.SCR.	321 0149 00		
2	D SOLDERING LUGS	304 6400 00		

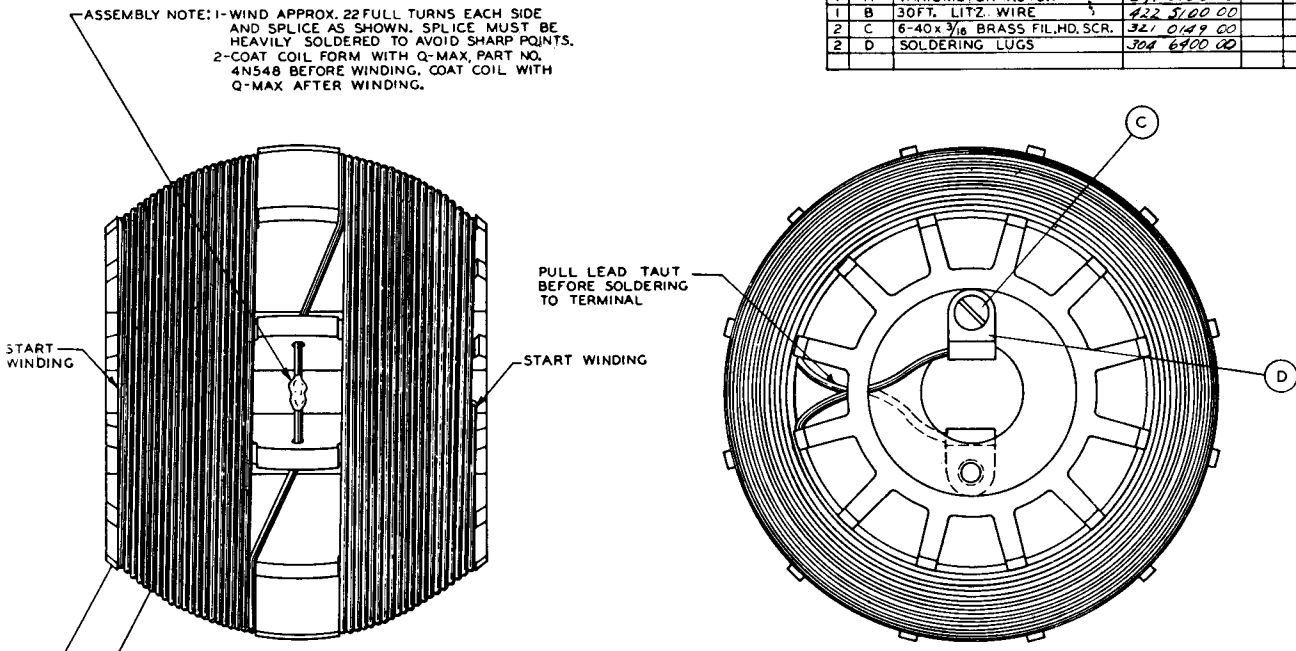

WIRE	GAUGE	PART NO.	NO. OF TURNS	TYPE OF WINDING	L	DIST. C	Q	FREQ.	CAP.
48 x 38 DOUBLE CELANESE LITZ WIRE	19	422N51	22	SINGLE LAYER	90 μh			1000 ~	

Figure 8-39. Type CU-25/ART-13 Antenna Loading Inductor Rotor for L702

ITEM	DESCRIPTION	PART NO.	MAT'L	FIN.
1	ITEM VARIOMETER ROTOR	571 0939 30		
1	B 13 FT. LITZ WIRE	422 5100 00		
2	C 6-40x 3/16 BRASS FIL HD SCR.	321 0149 00		
2	D SOLDERING LUG	304 6400 00		

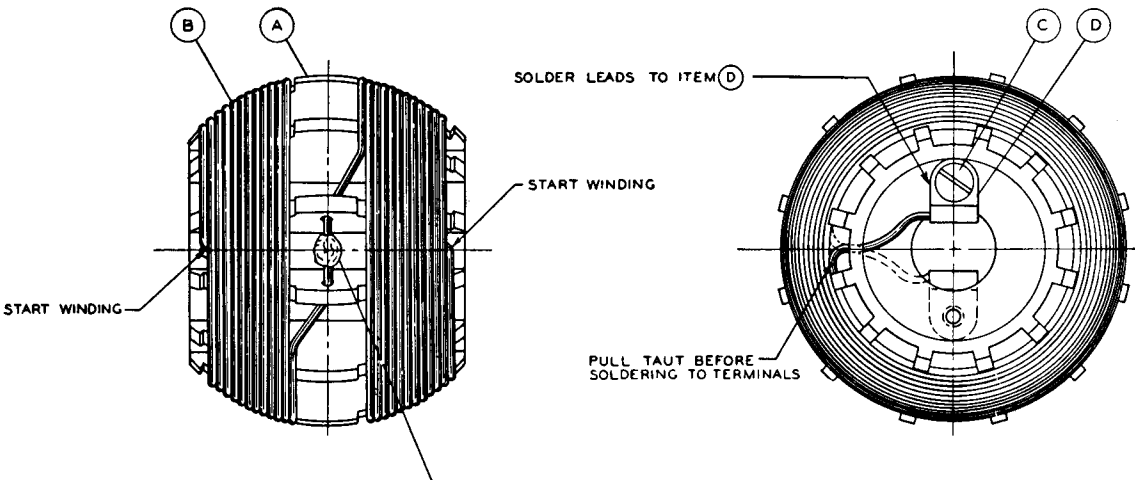

ASSEMBLY NOTES

COAT FORM WITH Q-MAX. PT. NO. 004 2136 00 BEFORE WINDING COIL.  
COAT COIL WITH Q-MAX AFTER WINDING.

WIRE	GAUGE	PART NO.	NO. OF TURNS	TYPE OF WINDING	L	DIST. C	Q	FREQ.	CAP.
48 x 38 DOUBLE CELANESE LITZ WIRE	19	422 3000 00		SINGLE LAYER	24 μh			1000 ~	

Figure 8-40. Type CU-26/ART-13 Antenna Loading Inductor Rotor for L802

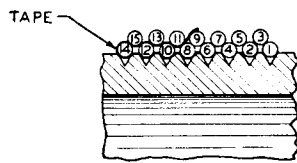
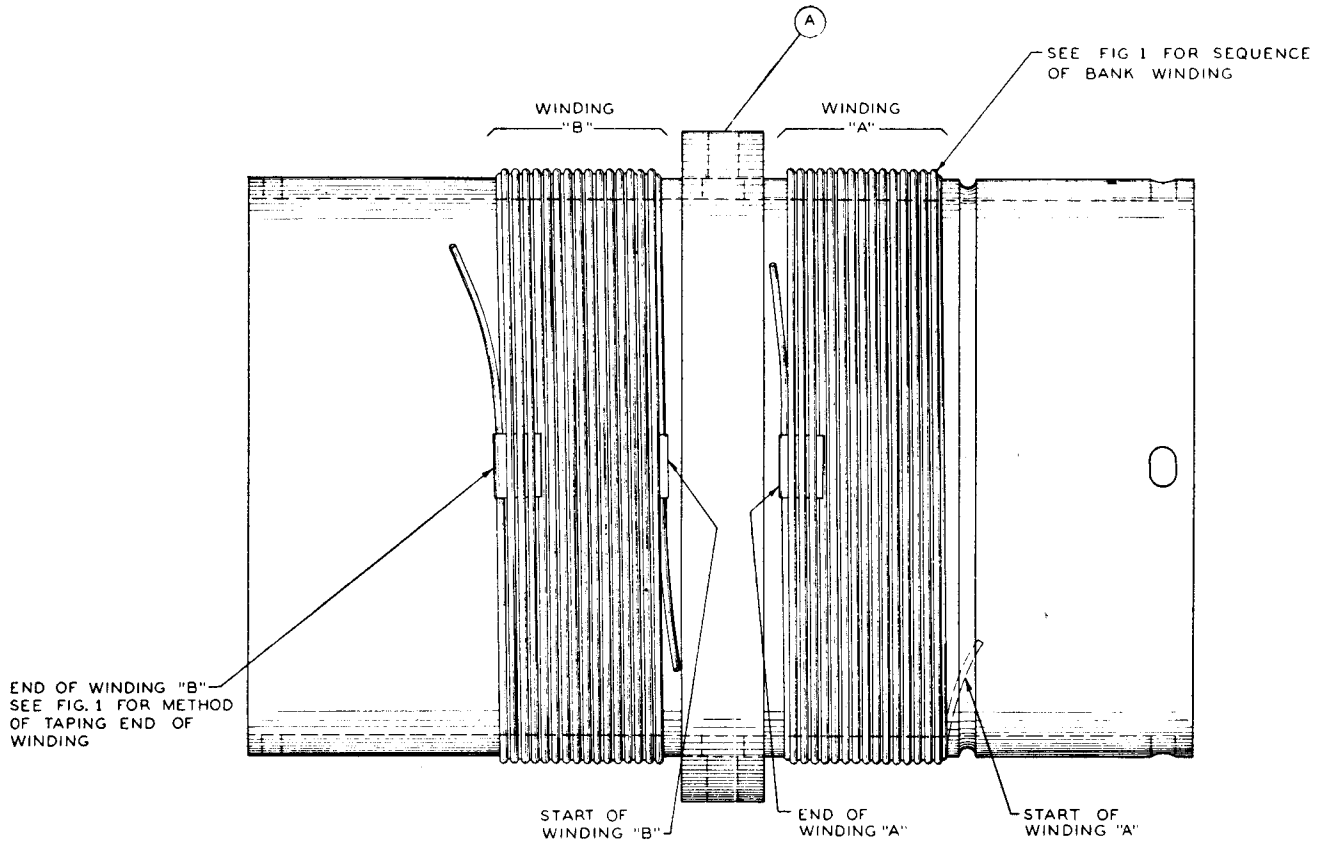

FIG. 1

METHOD OF TAPING  
END OF WINDING  
AND SEQUENCE OF  
BANK WINDING

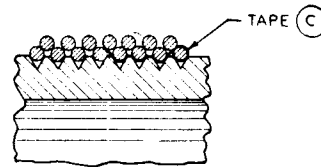

FIG. 2

METHOD OF TAPING  
START OF WINDING

NOTE -  
ALL LEADS  $2\frac{3}{4}$ " LONG  
AND TO BE STRIPPED  
AND TINNED

LT	PART NO.	DESCRIPTION
X	571 0608 40	WINDING ASSEMBLY
I A	571 1314 20	STATOR COIL FORM ASSY.
I B	422 5100 00	48 X 38 CELANESE COV'D LITZ-58FT
4 C	014 4000 00	TAPE 1/4 WIDE X .005

FOR SEQUENCE  
WINDING

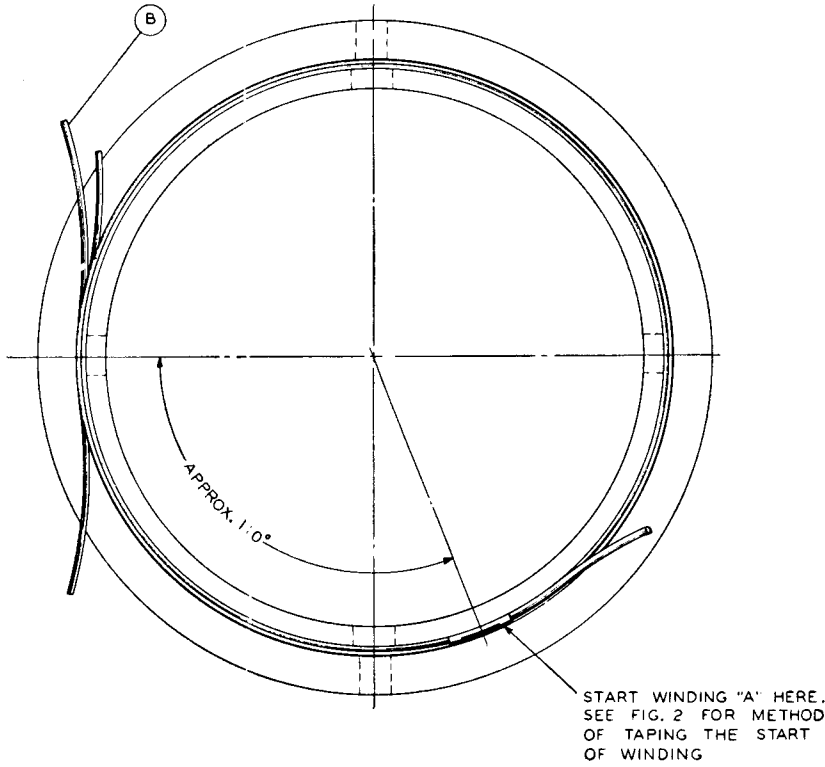

WINDING DATA

WIRE	GAUGE	PART NO.	APPROX NO. OF TURNS	TYPE OF WINDING	L	DIST. C	Q	FREQ.	CAP.
48 STRANDS OF #38 DOUBLE CELANESE COVERED	19	422 5100 00	WINDING "A" 30	DOUBLE BANK	105μh			1000~	
			WINDING "B" 31	DOUBLE BANK	116μh			1000~	

Figure 8-41. Type CU-25/ART-13 Antenna Loading Inductor Stator for L702

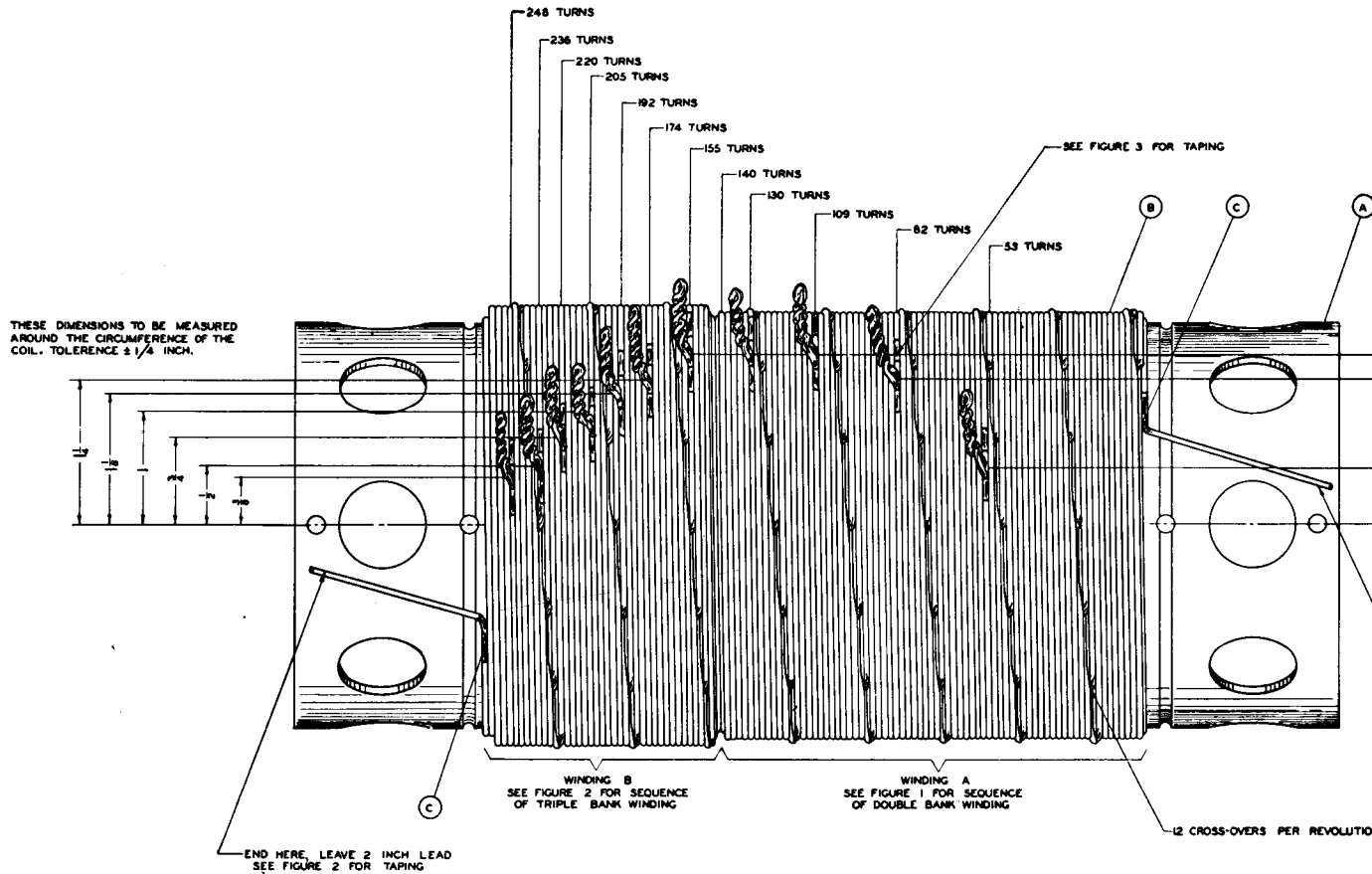

FIGURE 1  
METHOD OF TAPING START OF WINDING AND SEQUENCE OF DOUBLE BANK WINDING

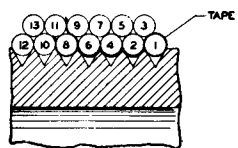

FIGURE 2  
METHOD OF TAPING END OF WINDING AND SEQUENCE OF TRIPLE BANK WINDING

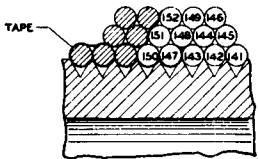

FIGURE 3  
METHOD OF TAPING





	A	571 1294 20	COIL FORM
	B	422 5100 00	243 FT CELANESE COVD LITZ
	C	016 4000 00	TAPE 1/4 WIDER 90° (2 FT)

FIGURE 3 FOR TAPING

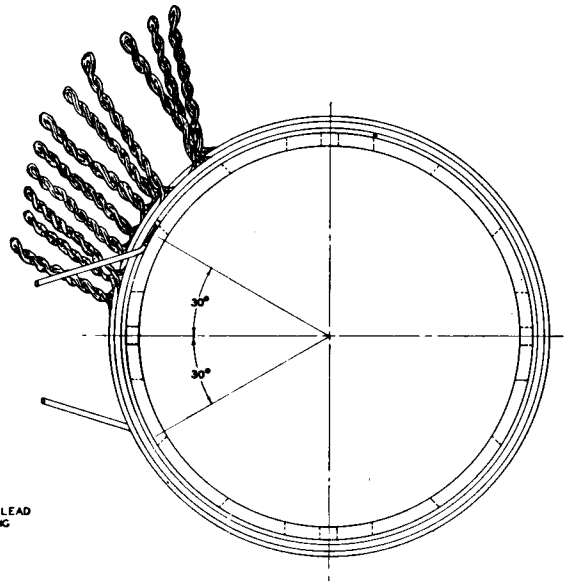
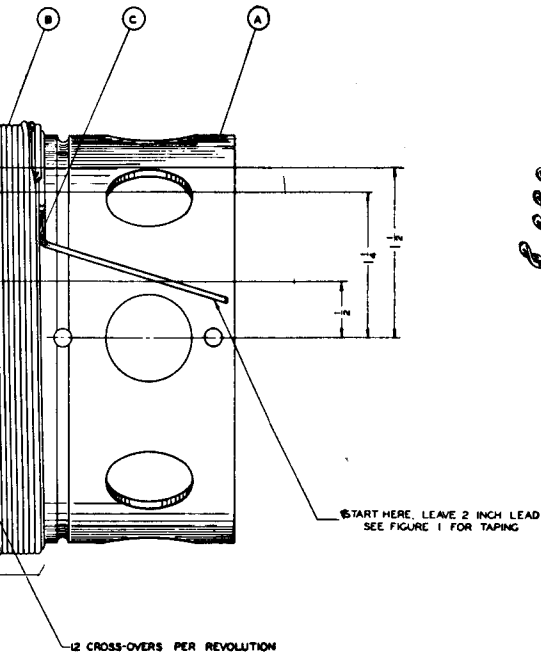

NOTES:  
1. COAT COIL FORM WITH Q-MAX BEFORE WINDING.

FIGURE 3  
METHOD OF TAPING AT TAPS

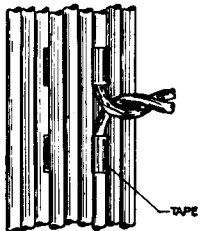
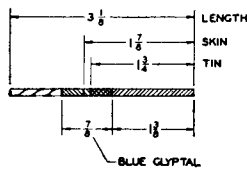

FIGURE 4  
METHOD OF SKINNING & TINNING  
TAP LEADS



WINDING DATA

WIRE	GAUGE	PART NO.	NO. OF TURNS	TYPE OF WINDING	L IN. IN AT TAPPED POSITION			FREQ. = 1000~		
					TURNS	L	TOL.	TURNS	L	TOL.
48 STRANDS OF NO. 36 DOUBLE CELANESE COVD LITZ	19	NEZ 7100 00	140 TURNS	DOUBLE BANK	53	300	±15.0μ	174	1845	±25.0μ
					82	585	±15.0μ	192	2040	±25.0μ
			119 TURNS	TRIPLE BANK	109	845	±15.0μ	205	2280	±35.0μ
					130	1070	±20.0μ	220	2520	±40.0μ
					140	1335	±20.0μ	234	2710	±40.0μ
			155	1585	±20.0μ	248	2880	±45.0μ		

Figure 8-42. Type CU-25/ART-13  
Antenna Loading Inductor L703

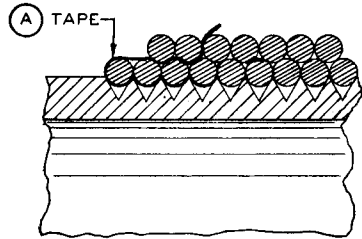
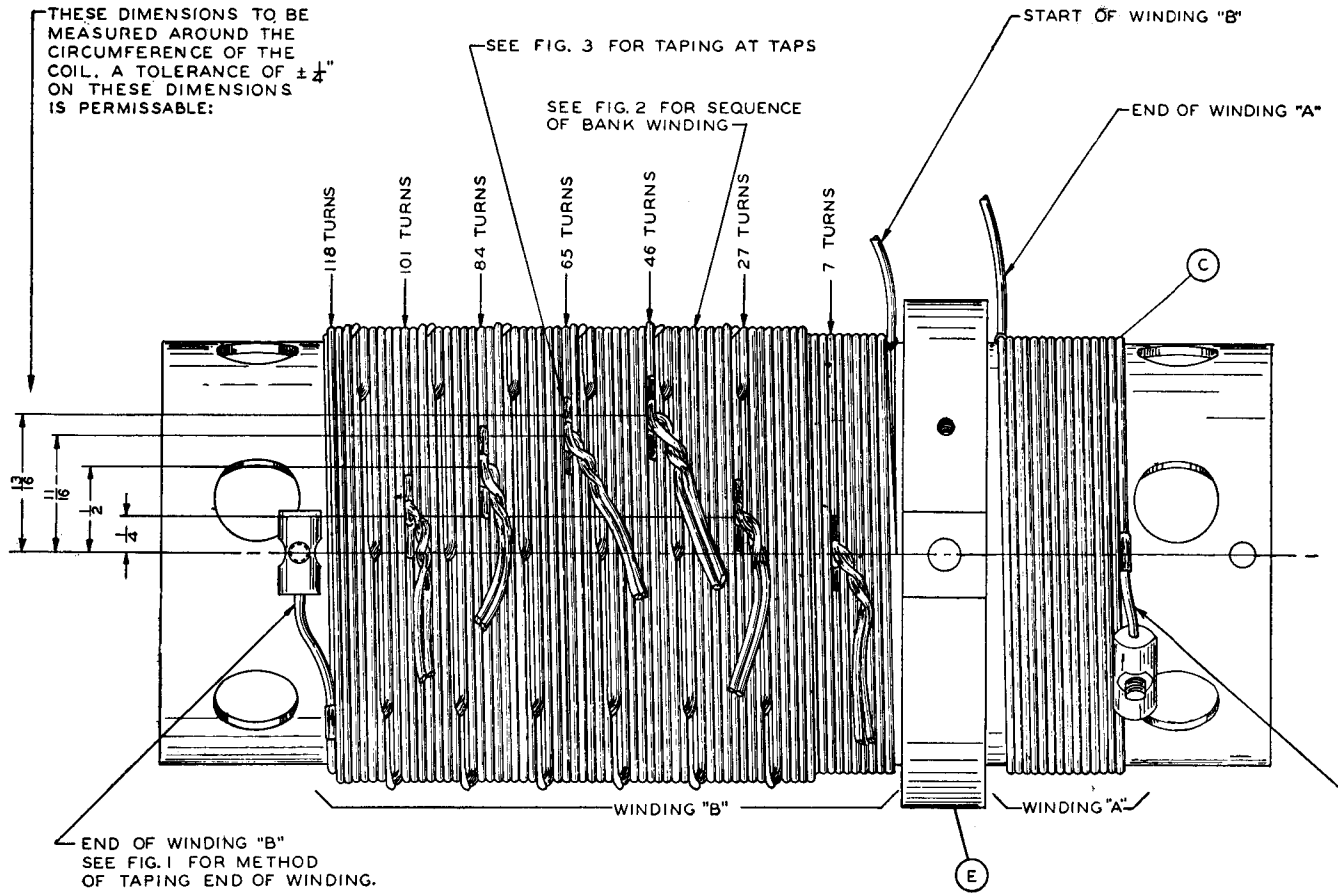

FIG. 1  
METHOD OF TAPING  
END OF WINDING

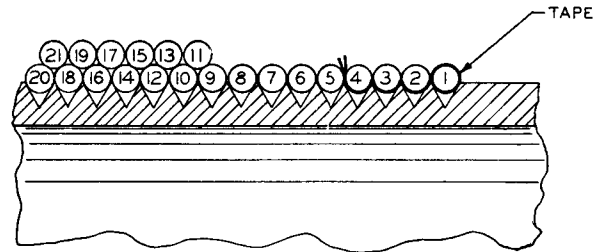

FIG. 2  
METHOD OF TAPING START  
OF WINDING AND SEQUENCE  
OF BANK WINDING

WINDING DATA

WIRE	GAUGE	PART NO.	APPROX. NO. OF TURNS	TYPE OF WINDING	L IN $\mu$ H AT TAPPED POSITIONS, FREQ. = 1000~						
					WINDG. "A"	7	27	46	65	84	101
48 STRANDS OF #38 DOUBLE CELANESE COV'D LITZ	19	422-5100 00	14 1/2	SINGLE LAYER	19				65	238	
			9	SINGLE LAYER	7				84	338	
			109	DOUBLE BANK			58		101	430	
							139		118	520	

QTY	UNIT	ITEM NO.	PART NUMBER	PART NAME
1.3	A	014 4000 00	1/4 WIDE X.005 TAPE FT.	
2	B	330 4240 00	6-32 X 3/8 FIBRE SCREW	
83	C	422 5100 00	CELANESE COV'D. LITZ FT.	
2	D	507 6116 10	COIL TERMINAL	
1	E	571 1257 20	STATOR COIL FORM ASS'Y.	

ING "B"

OF WINDING "A"

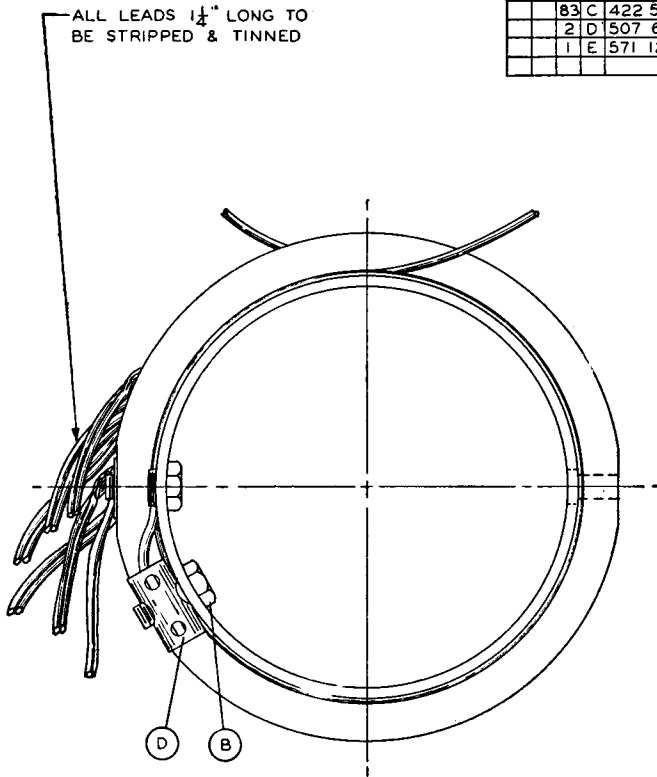

START OF WINDING "A"  
SEE FIG. 2 FOR TAPING  
START OF WINDING.

NOTE 1: DOPE COIL WITH Q-MAX  
004 5480 00 AFTER WINDING.

NOTE 2: FRACTIONAL TURNS ARE  
DESIGNATED AS COMPLETE  
TURNS IF MORE THAN 1/4 TURN.

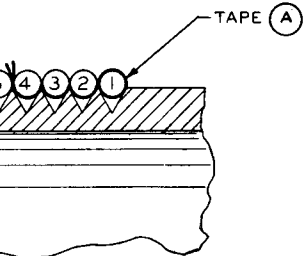

ING START  
SEQUENCE  
DING

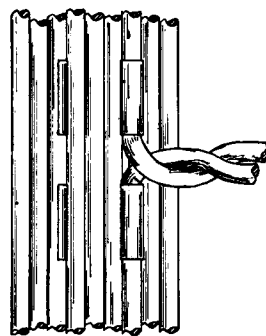
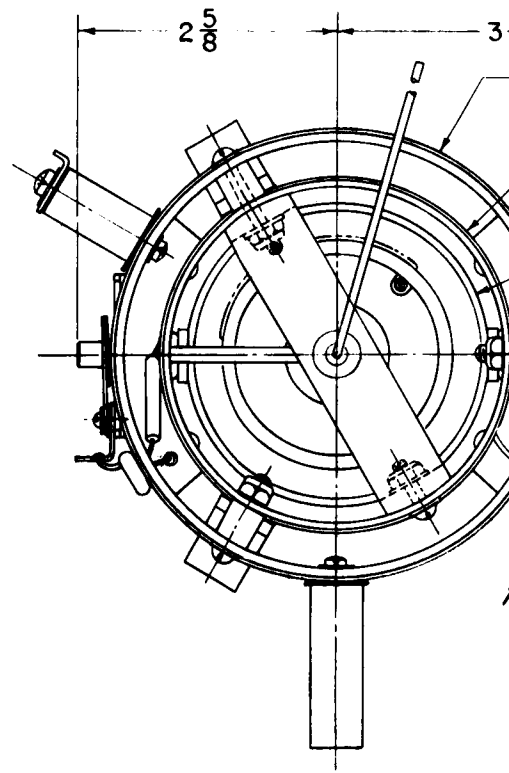
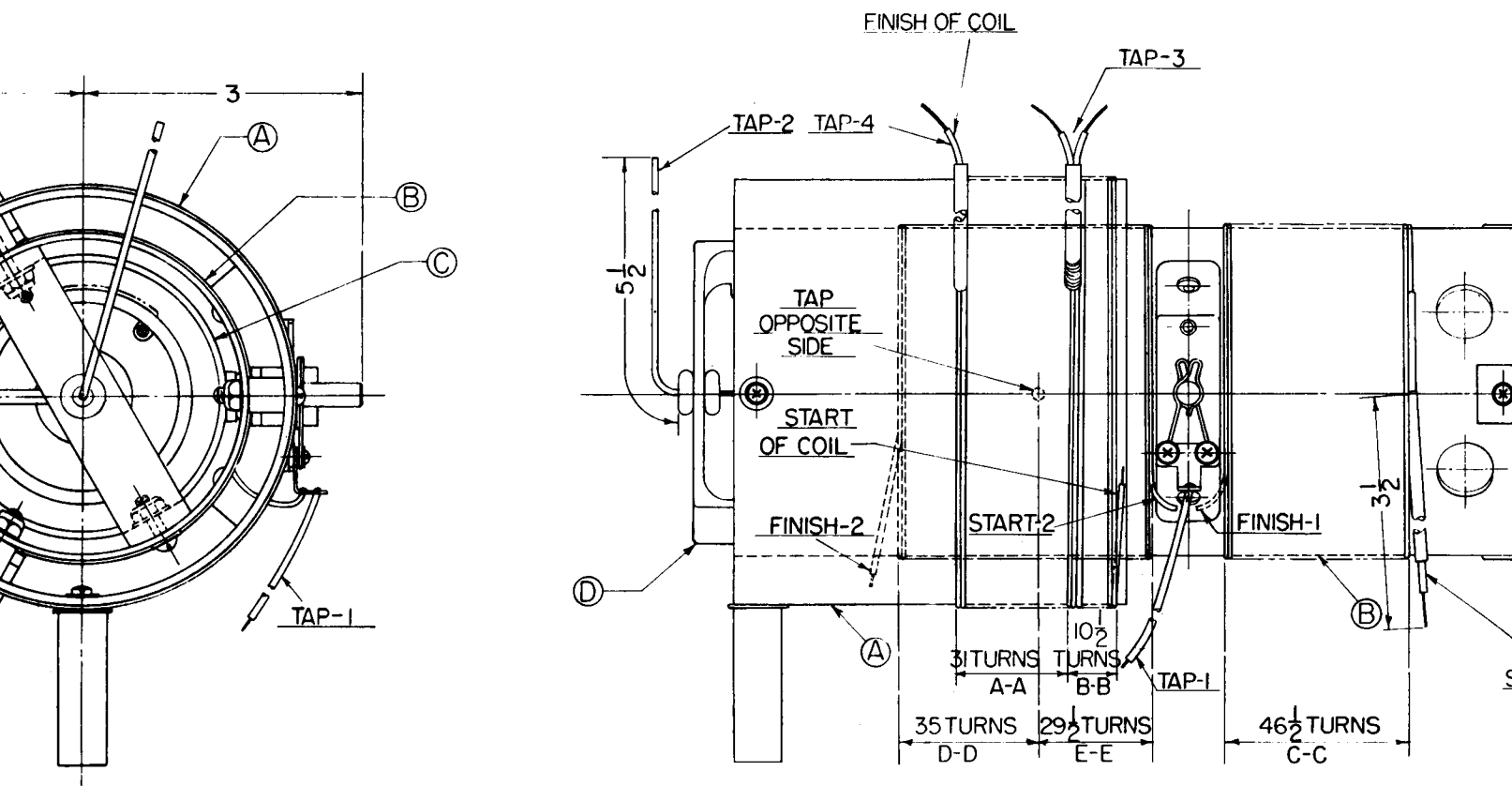

FIG. 3  
TAPING AT TAPS

Figure 8-43. Type CU-26/ART-13 Antenna Loading Inductor Stator for L802



ITEM	
1	A
1	B
1	C
1	D



WIRE	GAUGE
32 STRANDS 0.005 D.S.C.	0.04 OVERALL DIA.

Figure 8-43A. Type C  
Revised 15 July 1954

ITEM	DESCRIPTION	PART NO.	MAT'L	FINISH
1	A	OUTER STATOR ASSEMBLY	47D47370	
1	B	INNER STATOR ASSEMBLY	47G47372	
1	C	ROTOR ASSEMBLY	47D47376	
1	D	BOARD TERMINAL	47B47386	

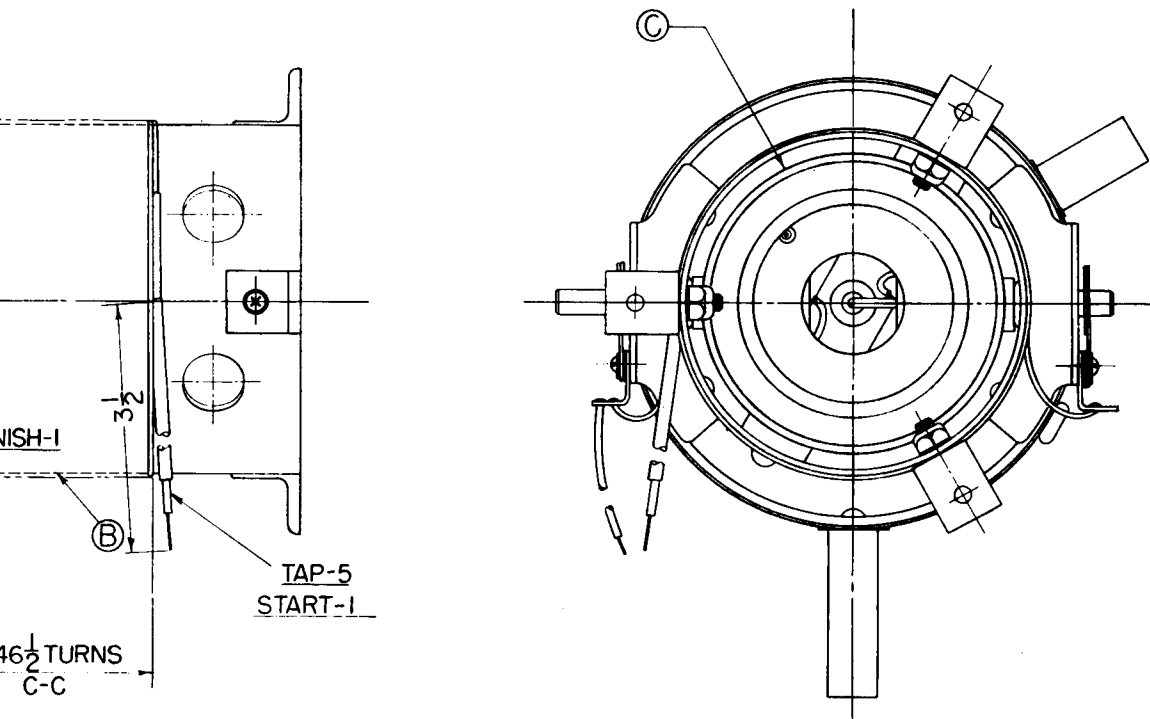

WIRE	GAUGE	PART NO.	NO. OF TURNS	TYPE OF WINDING	L	DIST. C	Q	FREQ.	CAP.
32 STRANDS 0.005 D.S.C.	0.040 OVERALL DIA.		A-A	3 TURNS	SINGLE LAYER WOUND				
			B-B	10 1/2 TURNS					
			C-C	46 1/2 TURNS					
			D-D	35 TURNS					
			E-E	29 1/2 TURNS					

Figure 8-43A. Type CU-32/ART-13A Antenna Loading Coil, Variometer Assembly L2501

15 July 1954

ITEM		
1	A	VAR
1	B	26
1	C	COF
2	D	BUS

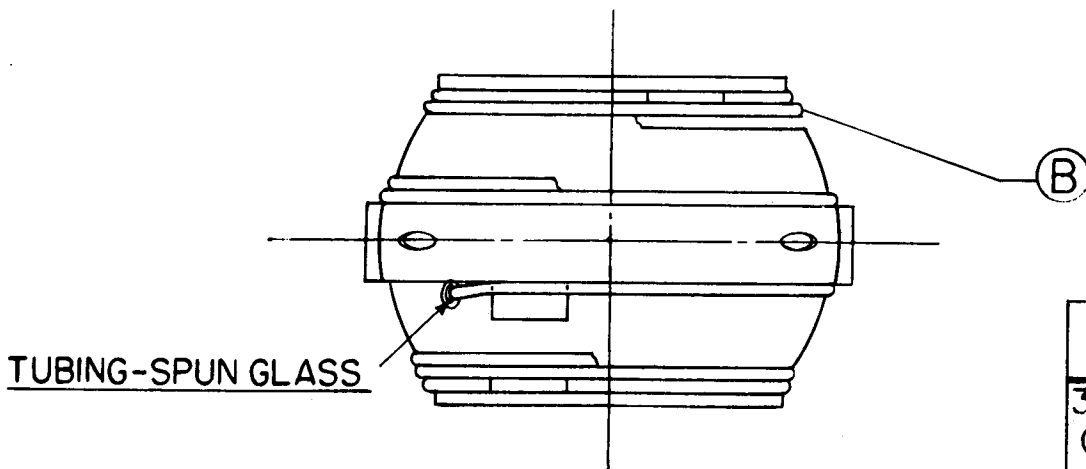
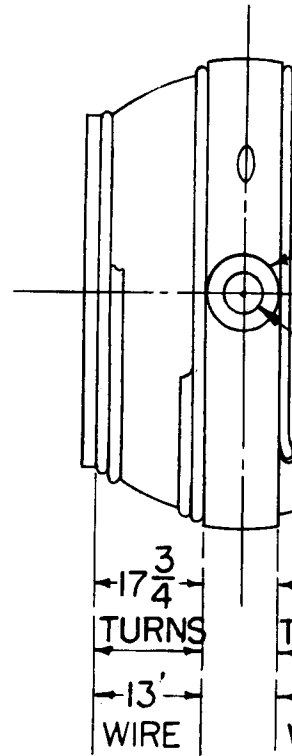
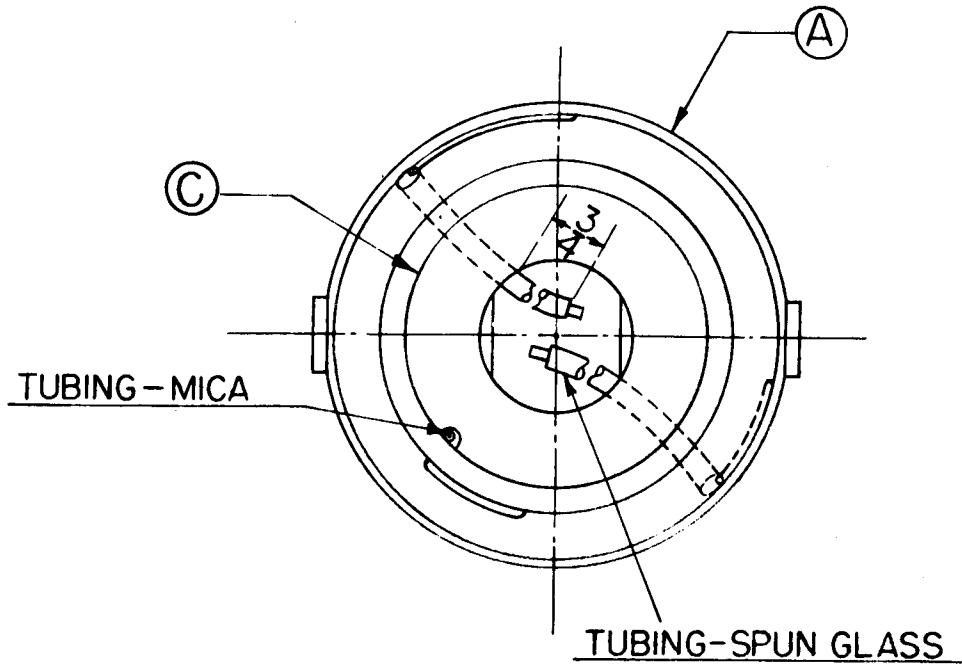

WIRE	GAUGE	PAP
32STRANDS 0.005,D.S.C. LITZ.	0.040 OVERALL DIA.	

Figure 8-43B.

Revised 15 July 1954

ITEM	DESCRIPTION	PART NO.	MAT'L.	FINISH
1 A	VARIOMETER ROTOR	47D47377		
1 B	26 FT. LITZ WIRE			
1 C	CORE-COIL, ROTOR	47B47378		
2 D	BUSHING, ROTOR	47D47379		

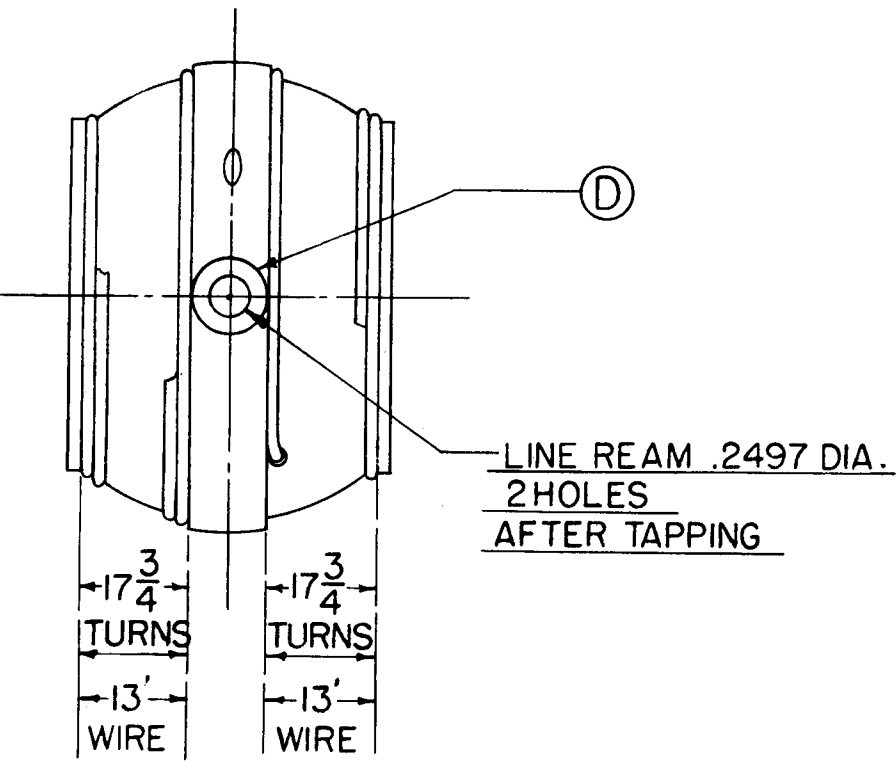

RE	GAUGE	PART NO.	NO. OF TURNS	TYPE OF WINDING	L	DIST. C	Q	FREQ.	CAP.
ANDS D.S.C. Z.	0.040 OVERALL DIA.		35 1/2	SINGLE LAYER WOUND					

Figure 8-43B. Type CU-32/ART-13A Antenna Loading Coil, Rotor for L2501

15 July 1954



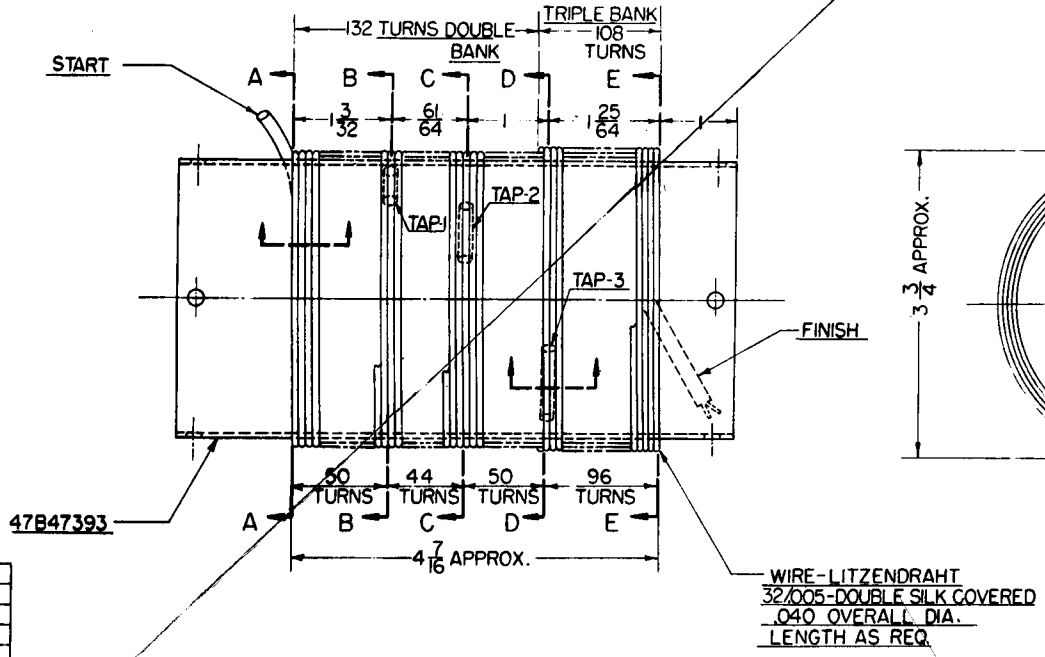

MAX. D.C. RESISTANCE	LOCATION	RESISTANCE
START TO TAP-1		65 OHM.
START TO TAP-2		1.22 OHMS.
START TO TAP-3		1.86 OHMS.
START TO FINISH		3.10 OHMS.

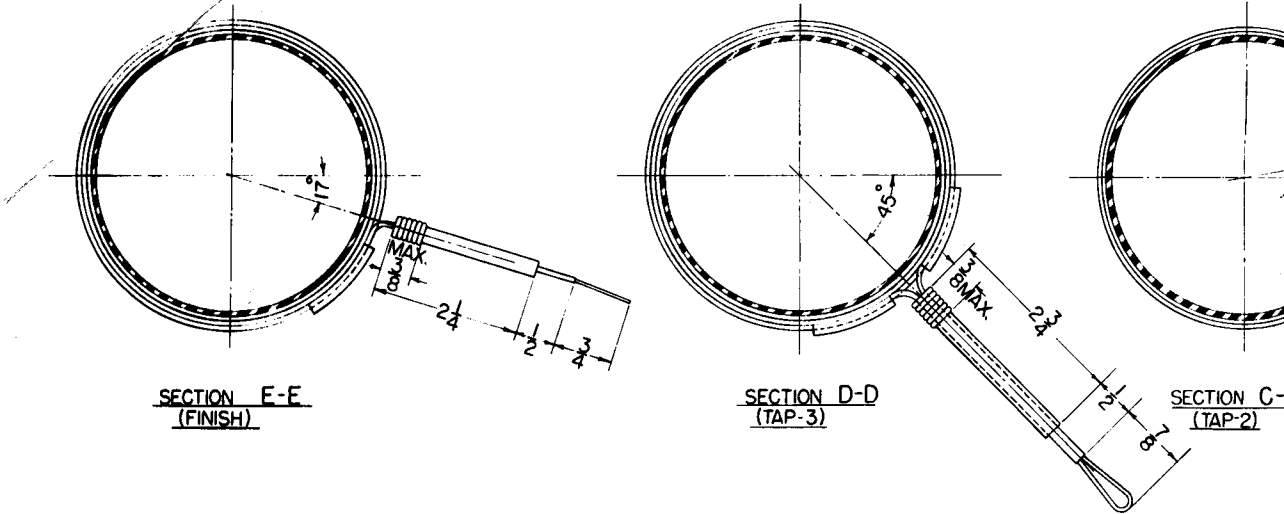

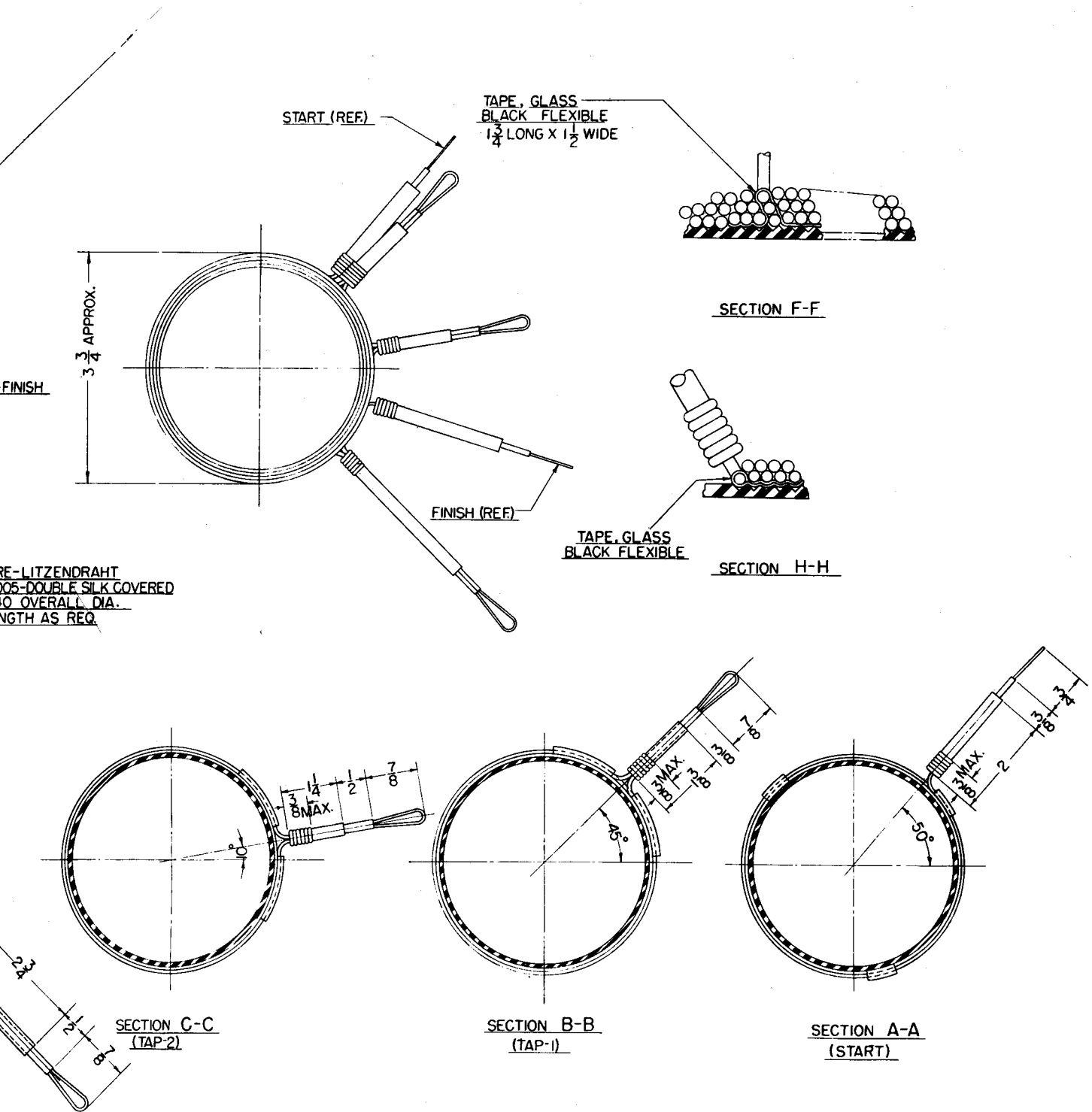

Figure 8-43C. Type CU-32/ART-13A Antenna Loading Coil, Coil R.F. L2502

Revised 15 July 1954

## INDEX

## A

"A" control, 2-7, 3-0, 3-17, 3-18, 4-12 thru 4-14, 4-24  
 Accessories,  
   equipment for trouble shooting, 5-4, 5-5, 5-27, 5-30, 5-32,  
   5-33  
   table of, 1-7  
 Adjustment,  
   antenna load boxes, 2-12, 2-13, 3-17  
   audio (see sidetone amplifier)  
   Autotune limit switches, 5-38, 5-39  
   CFI, 4-9, 5-30 thru 5-33  
   channel selections, 2-8 thru 2-15, 3-0 thru 3-3, 3-17 thru  
   3-19  
   HFO, 2-8 thru 2-12, 3-3, 5-25 thru 5-27  
   LFO, 2-12, 2-13, 3-2, 3-3, 5-24, 5-24A, 5-25  
   MCW, 4-9, 4-10, 5-32  
   multiplier, 2-11, 2-12, 3-0 thru 3-3, 5-28 thru 5-30  
   relay, 5-43 thru 5-46  
   sidetone amplifier, 2-13, 2-14, 3-1  
   transmitter controls, 2-7, 2-8, 3-0 thru 3-3  
 Aerial (see antenna)  
 Air gap breakdown (see arc)  
 Alignment,  
   CFI, 5-30 thru 5-33  
   HFO, 5-25 thru 5-28  
   LFO, 5-24, 5-25  
   multiplier, 5-28 thru 5-30  
 Altitude,  
   provision for, 1-2, 1-3, 3-1, 3-17, 4-1, 4-4, 5-21  
 Ammeter, antenna, calibration of, 5-4  
 Amplifier,  
   power, 4-15  
   sidetone, 2-13, 2-14, 4-8, 4-9, 5-5, 6-1  
   speech (audio), 1-2, 4-6, 4-7, 5-4  
 Antenna,  
   ammeter (see ammeter, antenna)  
   connections, 2-6, 2-7  
   dummy, 2-1, 5-4  
   impedance, 1-2, 1-3  
   leads, installation of, 2-6, 2-7  
   length, 1-2, 4-16  
   loading coils, 1-2, 1-7, 1-8, 2-4, 2-5, 2-12, 2-13  
   requirements, depending on frequency, 1-2, 6-23  
   shunt capacitor, 1-2, 1-8, 2-1, 2-4, 2-6, 4-16  
   tuning data, 1-2, 3-20, thru 3-26, 6-23  
 Arc, 1-3, 2-7, 2-11, 3-0, 3-1, 3-17, 3-19  
 Audio oscillator (see MCW)  
 Audio system,  
   adjustment of, 2-13, 2-14  
   circuit (see unit schematic)  
   data, 6-1 thru 6-3  
   frequency response, 1-2, 6-1  
   input impedance, 6-23  
   input transformer, 4-7  
   output impedance, 2-1  
   practical wiring diagram, 8-33  
   sidetone, 2-13, 2-14, 3-1, 6-1  
   unit replacement, 5-22  
   unit schematic, 8-21

Autotune system,  
   electrical portion of, 4-20 thru 4-24  
   function of, 1-1, 4-16, 4-24  
   maintenance of, 5-33 thru 5-43  
   mechanical portion of, 4-16 thru 4-20  
   motor, 4-16, 4-19, 4-20, 5-6, 5-60 thru 5-67, 6-9, 6-10  
   operation of, 4-16 thru 4-24  
   operation sequence, 4-21, 4-22  
   parts of, 5-39, 5-40, 7-53  
   positioning, accuracy, 1-1, 4-16  
   positioning mechanism, 5-37 thru 5-39  
   synchronization, 5-36, 5-37  
   synchronization check, 5-35, 5-36  
 Auxiliary connections (optional), 2-6

## B

"B" control, 2-7, 3-0, 3-2, 3-3, 3-17, 3-18, 4-13, 4-24  
 Band, frequency, 4-13 thru 4-16, 6-22  
 Battery voltage, 2-9, 2-14, 5-2  
 Beat note, 2-9, 2-12, 3-2, 3-3, 5-25, 5-31 thru 5-33  
 Bleeder,  
   low voltage, 4-12, 4-13  
   microphone circuit, 4-6  
 Boxes, antenna load, 2-12, 2-13, 3-17  
 Box, (unit) pilot's control (see pilot's control)  
 Breakdown (see arc)  
 Buffer (see multiplier)

## C

"C" control, 2-7 thru 2-12, 3-0, 3-17, 3-18, 4-15, 4-16, 4-24  
 Calibration,  
   antenna ammeter, 5-4  
   frequency interpolation, 3-3  
   HFO, 5-25 thru 5-27  
   LFO, 5-24, 5-24A, 5-25  
   oscillator (CFI), 5-30 thru 5-33  
 Capacitor color code (see color code)  
 Carbon microphone, 1-7, 2-1  
 CFI,  
   servicing, 5-22, 5-30 thru 5-33  
   wiring diagram, 8-35  
 Charts,  
   HFO tuning, 6-6A thru 6-8  
   LFO tuning, 6-4 thru 6-6  
   vacuum tube, 6-25 thru 6-34  
 Checks,  
   Autotune synchronization, 5-35, 5-36  
   operational, 2-1, 2-2  
   preflight operational, 5-1  
   routine, 5-1 thru 5-3  
 Chain drive,  
   replacement of, 5-42  
 Channel selection,  
   adjustment of, 2-8 thru 2-15, 3-0 thru 3-3  
 Chokes,  
   PA plate feed HF, 4-15, 8-46  
   PA plate feed LF, 4-15  
   static drain, 8-46

- Circuit,  
 antenna shunt capacitor, 8-24  
 audio unit, 8-21  
 Autotune operation sequence, 4-21, 4-22  
 Autotune motor, 6-9  
 CFI, 4-8  
 complete equipment, 8-10  
 dynamotor, 6-10, 6-11  
 emission selection and control, 4-5  
 filament, 4-4  
 HFO, 4-12, 8-21  
 high voltage, 4-5  
 LF-RF, 4-11  
 LFO unit, 8-25, 8-26  
 loading coils (antenna), 8-26A  
 MCW-CFI unit, 8-21  
 modulator, 4-7, 8-21  
 multiplier, 4-14, 8-21  
 oscillator MCW, 4-10  
 pilot's control unit, 8-24  
 power control, 4-2  
 power supply, 8-23, 8-24  
 RF power amplifier HF, 4-14  
 sidetone amplifier, 4-8  
 speech amplifier, 4-6  
 transmitter, 8-21
- Circuit selecting relay (output), 4-12, 4-15, 5-45, 5-46, 5-53, 5-54
- Coil (see inductor)
- Color code,  
 capacitor, RMA, 6-11, 6-12  
 capacitors, ASA, 6-13 thru 6-18  
 resistor, RMA, 6-13  
 resistors, ASA, 6-18, 6-19  
 wire, 6-19 thru 6-22
- Commercial assemblies, 5-43 thru 5-78
- Connections,  
 inspection of, 2-1, 5-1, 5-6 thru 5-9  
 inter-unit, 2-5 thru 2-7  
 optional auxiliary, 2-6  
 power, 2-5
- Connectors,  
 antenna, 2-6, 2-7  
 ground, 2-6, 2-7  
 load coil, 2-6  
 power, 2-5  
 receiver, 2-6  
 relay, external, 4-15  
 remote, 2-5  
 hunt capacitor, 2-6  
 sidetone, 2-6
- Contents,  
 table of, i thru iv
- Contractual guarantee, xi
- Control,  
 "A", 2-7, 3-0, 3-17, 3-18, 4-12 thru 4-14, 4-24  
 "B", 2-7, 3-0, 3-2, 3-3, 3-17, 3-18, 4-13, 4-24  
 "C", 2-7 thru 2-12, 3-0, 3-17, 3-18, 4-15, 4-16, 4-24  
 "D", 2-8 thru 2-11, 3-0, 3-17, 3-18, 4-16, 4-24  
 "E", 2-8, 2-10, 3-0, 3-17, 3-18  
 "F", 2-8, 2-12, 2-13, 3-0, 3-17  
 "G", 2-12, 2-13, 3-0, 3-17  
 "H", 2-12, 2-13, 3-17  
 "J", 2-12, 2-13, 3-17  
 "K", 2-12, 2-13, 3-17  
 "L", 2-12, 2-13, 3-17
- Controls,  
 adjustment of, 2-7, 2-8, 3-0 thru 3-3  
 function of, 2-7, 2-8, 3-0, 3-1  
 HF, setting of, 2-8 thru 2-12, 3-3  
 LF, setting of, 2-12, 2-13, 3-2, 3-3  
 locking of, 2-8 thru 2-12, 3-0  
 pilot (remote), 2-4, 2-14, 2-15, 3-0, 4-3, 4-4
- Corrector knob,  
 HFO, 2-9, 3-3  
 LFO, 2-12, 3-2, 3-3
- Corona discharge (see arc)
- Corrosive action, 1-1
- Cover,  
 Autotune, 5-35, 5-40  
 load box, 5-21  
 power control unit, 5-21  
 transmitter, 2-1
- Cover plate,  
 HFO, 5-22, 5-23, 5-26
- Crystal,  
 frequency of, 1-8, 2-1  
 mounting, 1-8, 2-1  
 use (see CFI)
- Currents,  
 typical operating, 5-11 thru 5-14
- CW,  
 monitoring, 4-10, 5-2, 5-4, 5-5  
 operation, 2-8 thru 2-13, 4-3  
 relay, 4-1 thru 4-4, 4-6, 4-8, 5-45, 5-49, 5-50
- D**
- "D" control, 2-8 thru 2-11, 3-0, 3-17, 3-18, 4-16, 4-24
- Data,  
 audio frequency, 6-1 thru 6-3  
 Autotune motor, 5-60 thru 5-67, 6-9, 6-10  
 color code, 6-11 thru 6-22  
 dynamotor, 5-68 thru 5-78, 6-10, 6-11  
 equipment, 1-5 thru 1-7, 6-1 thru 6-34  
 HFO calibration, 3-6B thru 3-16, 6-6 thru 6-8  
 LFO calibration, 3-4, 3-5, 3-6, 3-6A, 6-4, 6-5  
 relay, 5-43 thru 5-58  
 tube, 5-3 thru 5-5, 6-25 thru 6-34  
 MCW-CFI, 6-2, 6-3  
 transmitter, 6-1 thru 6-34
- Detuning, 3-18, 5-31
- Dial reading interpolation,  
 (oscillators), 3-3
- Dials (see controls)
- Dimensions,  
 antenna, 1-2, 4-16  
 antenna lead clearance, 2-6, 2-7  
 installation, 2-3 thru 2-5  
 key, remote, 5-59  
 mapor units, 1-5, 1-6, 8-1 thru 8-18  
 relay, 5-48 thru 5-58
- Discharge,  
 corona (see arc)
- Distortion,  
 audio, 1-2, 6-1  
 sidetone, 6-1
- Destruction of abandoned material in the combat zone, ix
- Doubler (see multiplier)

Drawings (see list of illustrations)  
 Driver transformer, 4-7  
 Dummy LFO unit,  
   removal of and replacement by LFO, 3-1, 3-2, 5-22  
 Dynamic microphone, 1-7, 2-1  
 Dynamotor,  
   data, 5-68 thru 5-78, 6-10, 6-11, 6-23, 6-24  
   drawing, 5-71, 5-72, 5-78  
   input relay, 4-1 thru 4-5, 5-55  
   inspection, 5-21  
   maintenance, 5-1, 5-21  
   mounting plate, 2-3, 2-4  
   output voltage, 6-10, 6-11, 6-23, 6-24  
   overload relay, 1-4, 2-3, 2-7, 5-6  
   parts, 5-70, 5-75, 5-77  
   parts list, 5-68, 5-69, 5-73, 5-74, 5-76, 7-30, 7-40, 7-41, 7-46  
   power unit, 2-3 thru 2-5, 5-21  
 RESET (see overload relay)  
 schematic, 8-23, 8-24

**E**

"E" control, 2-8, 2-10, 3-0, 3-17, 3-18  
 Earphones (see headphones)  
 Equipment,  
   inspection (see checks)  
   interchangeability of, 1-9  
   list of, 1-5 thru 1-7  
   supplied, 1-5, 1-6  
   trouble shooting, 5-5 thru 5-9  
   required, 1-7  
 Explanatory notes (installation), 2-6, 2-7

**F**

"F" control, 2-12, 2-13, 3-0, 3-17  
 Failure (see maintenance),  
   report of, ix  
 Fiducial (see corrector knob)  
 Filament,  
   arrangement, 4-4, 5-4  
   circuit, 4-4  
 Final amplifier, 4-10 thru 4-11, 4-15  
 Frequency,  
   audio response, 1-2, 6-1  
   band, 4-13 thru 4-16, 6-22  
   change system (see Autotune system)  
   range, 1-2, 4-10, 4-13, 6-22  
   stability, 6-22  
 Function of controls, 2-7, 2-8, 3-0, 3-1  
 Fuse, 2-5, 5-6

**G**

"G" control, 2-12, 2-13, 3-0, 3-17  
 General specifications, 6-22 thru 6-24  
 Glossary of terms, 6-35  
 Guarantee,  
   contractual, xi  
 Ground, 2-4, 2-6, 2-7  
 Grounding strap, 2-4

**H**

"H" control, 2-12, 2-13, 3-0, 3-17  
 Half power, 1-2, 1-3, 4-1, 6-1  
 Harmonic operation, 2-11 thru 2-13  
 Headphones, 1-7, 2-1  
   cord, 1-7  
   cord plug, 1-7

High frequency,  
   oscillator, 2-8 thru 2-12, 3-3, 5-25 thru 5-27  
   output tuning, 3-17 thru 3-19  
   oscillator wiring diagram, 8-29  
 High voltage circuits, 4-5

**I**

Illustrations,  
   list of, v thru viii  
 Impedance,  
   audio input, 6-23  
   antenna, 1-2, 1-3  
 Inductor,  
   antenna loading, 8-49, 8-52 thru 8-58  
   HFO grid, 8-43  
   LFO grid, 8-50A, 8-51  
   multiplier plate, 8-44, 8-45  
   PA tank padding, 8-50  
   variometer, 8-47, 8-48  
   (see chokes)  
 Input transformer,  
   audio, 4-7  
 Installation,  
   connections, 2-5 thru 2-7  
   drawings (see list of illustrations)  
   explanatory notes, 2-6 2-7  
   LFO, 3-1, 3-2, 5-22, 5-24A  
   of optional auxiliary connections, 2-6  
   of units, 2-3 thru 2-5, 5-21 thru 5-24  
 Interconnecting wires (see connections)  
 Interlock switch,  
   Autotune, 4-20 thru 4-24  
   keying, 3-0, 4-6, 4-24  
 Interpolation,  
   oscillator reading, 3-3  
 Inter-unit connections, 2-5 thru 2-7

**J**

"J" control, 2-12, 2-13, 3-0, 3-17  
 Jacks,  
   key, 1-4, 3-1, 4-5, 4-6  
   microphone, 1-2, 1-4, 3-1, 4-5 thru 4-7  
   sidetone, 1-4, 2-6, 3-1, 3-2, 4-8, 4-9  
   throttle switch, 1-4, 3-1, 4-5, 4-6

**K**

"K" control, 2-12, 2-13, 3-0, 3-17  
 Key,  
   cord, 1-7  
   jack, 1-4, 3-1, 4-5, 4-6  
   plug, 1-7  
   telegraph, 1-7  
   test, 1-4, 3-1, 4-5, 4-6  
   remote, 5-59 (see pilot's control unit)  
 Keying,  
   interlock switch, 3-0, 4-6, 4-24  
   relay, 4-6, 4-9, 4-12, 4-13, 4-20, 5-6, 5-44 thru 5-48  
   speed, 1-1, 1-2, 5-44, 5-45

**L**

"L" control, 2-12, 2-13, 3-0, 3-17  
 Leads,  
   antenna, 2-6, 2-7  
   antenna shunt capacitor, 2-4, 2-6  
 Limit switch,  
   adjustment of, 5-38, 5-39

Autotune, 4-20 thru 4-24  
 function, 4-20  
 Line shaft, replacement of, 5-42, 5-43  
 replacement of bearings, 5-42  
 replacement of sprocket, 5-42  
 LFO installation, 3-1, 3-2, 5-22  
 Load coils (antenna),  
 adjustment of, 2-12, 2-13, 3-17  
 installation of, 1-2, 1-7, 1-8  
 servicing of, 5-21  
 Loading control (see control "E")  
 Local-remote switch, 2-7, 4-3, 4-4, 4-20  
 Locks,  
 control, 2-8 thru 2-12, 3-0  
 Low frequency,  
 oscillator function, 4-10 thru 4-12  
 output tuning, 2-12, 2-13, 3-17  
 servicing, 5-24, 5-24A, 5-25  
 oscillator wiring diagram, 8-41  
 Lubrication,  
 Autotune system, 5-33 thru 5-35  
 Low voltage,  
 bleeder, 4-12, 4-13  
 dynamotor section, 6-10, 6-11, 6-23, 6-24  
 fuse, 2-5, 5-6

**M**

Maintenance,  
 antenna loading coils, 5-21  
 Autotune, 5-33 thru 5-43  
 dynamotor, 5-1, 5-21  
 general, 5-3  
 HFO, 5-23 thru 5-27  
 LFO, 5-24, 5-24A, 5-25  
 MCW-CFI, 5-22, 5-30 thru 5-33  
 multiplier, 5-22, 5-23, 5-28 thru 5-30  
 pilot's control unit, 5-21  
 power control unit, 5-21  
 Manual Autotune position, 1-2, 2-9, 4-16  
 Manufacturers,  
 list of, 7-54, 7-55  
 MCW,  
 adjustment, 4-9, 4-10, 5-32  
 operation, 2-13, 4-5, 4-6, 4-9, 4-10  
 output control, 4-9, 4-10, 5-32  
 practical wiring diagram, 8-35  
 servicing, 5-22, 5-32  
 Meter,  
 antenna, 5-4  
 circuit selector switch, 3-1  
 M102, 5-2, 5-3  
 Microphone,  
 bleeder circuit, 4-6  
 characteristics of, 1-2, 1-7, 2-1  
 cord, 1-7  
 jack, 1-2, 1-4, 3-1, 4-5 thru 4-7  
 plug, 1-7  
 switch, 1-2, 2-1, 2-8  
 types, 1-2  
 Modulation,  
 percentage of and type of, 1-2, 4-7, 6-1  
 transformer, 4-7, 4-8  
 Modulator,  
 circuit, 4-7  
 Monitoring, 4-10, 5-2, 5-4, 5-5

Motor,  
 Autotune, 4-16, 4-19, 4-20, 5-6, 5-60 thru 5-67, 6-9, 6-10  
 control relay, 4-20, 5-44  
 Mounting,  
 dimensions, 2-3 thru 2-5, 8-1 thru 8-18  
 Multiplier,  
 alignment of, 5-28 thru 5-30  
 practical wiring diagram, 8-31  
 range switch, 4-13, 4-14  
 schematic, 4-14, 8-21  
 servicing, 5-22, 5-23, 5-28 thru 5-30  
 Multiturn line shaft assembly,  
 servicing of, 5-41 thru 5-43

**N**

Network switch (see output)  
 Nul-point (see CFI oscillator calibration)

**O**

Oiling (see lubrication)  
 Operate (see power level switch)  
 Operational checks,  
 preflight, 5-1  
 routine, 5-1 thru 5-3  
 Operation,  
 procedure, 3-0 thru 3-3, 3-17 thru 3-19  
 Oscillator,  
 calibration, 5-24 thru 5-27  
 casting, removal of, 5-23, 5-24  
 CFI, 5-22, 5-30 thru 5-33  
 HF, 2-8 thru 2-12, 3-3, 5-25 thru 5-27  
 LF, 2-12, 2-13, 3-2, 3-3, 5-24, 5-24A, 5-25  
 MCW, 4-9, 4-10, 5-22, 5-32  
 Output,  
 circuits, 4-10 thru 4-12, 4-15, 4-16  
 control, sidetone, 2-13, 2-14, 3-1  
 frequency, 1-2, 4-10 thru 4-16, 6-22  
 network switch, 3-0, 4-15, 4-16, 4-24  
 power, 1-2, 1-3  
 sidetone, 2-14, 6-1  
 tuning, 2-8 thru 2-13, 3-17 thru 3-19  
 Output circuit selecting relay, 4-12, 4-15, 5-45, 5-46, 5-53,  
 5-54  
 Overload relays, 1-4, 2-3, 2-7, 5-6

**P**

Parts list,  
 antenna shunt capacitor, 7-25  
 audio unit, 7-15 thru 7-17  
 Autotune, 5-39, 5-40, 7-53  
 Autotune motor, 5-60, 5-64, 5-66  
 Autotune motors, alternate, 7-47  
 CFI unit, 7-32 thru 7-35  
 dynamotor, 5-68, 5-69, 5-73, 5-74, 5-76, 7-30, 7-40, 7-41  
 7-46  
 LFO unit, 7-18 thru 7-21, 7-42, 7-42A  
 load boxes (antenna), 7-23, 7-24  
 miscellaneous, 7-48 thru 7-53  
 pilot's control unit, 7-22  
 pilot's control unit key, 5-59  
 power unit, 7-26 thru 7-29, 7-36 thru 7-39, 7-42 thru 7-45  
 relays, 5-47, 5-49, 5-51, 5-53, 5-55 thru 5-57  
 transmitter, 7-2 thru 7-14  
 unit assemblies, 7-48  
 Percentage,  
 of distortion, 1-2, 6-1  
 of modulation, 1-2, 4-7, 6-1

Photographs (see list of illustrations)

Pilot's control unit,

connection of, 2-5, 2-6

installation, 2-5

mounting dimensions, 8-13, 8-13A

mounting plate, 2-4

operation of, 2-14

parts list, 7-21, 7-22

practical wiring diagram, 8-39, 8-40

schematic, 8-24, 8-24A

servicing, 5-21

telegraph key, 5-59

Pilot lamp, 4-3

Power,

connections, 2-5

contactor, primary, 4-1 thru 4-5, 5-46, 5-56

control circuits, 4-1 thru 4-5

control unit (see dynamotor power unit)

input, 1-3, 6-1, 6-23

output, 1-3, 6-23

source, 1-3, 6-23

unit servicing, 5-1, 5-21

Power amplifier,

circuit, 4-11, 4-14

description, 4-15, 4-16

tube, 4-15, 5-5

Power change relay, 1-2, 1-3, 3-1, 3-17, 4-1, 4-4, 5-21

Power level switch (calibrate-tune-operate), 3-1, 4-1, 4-3, 4-6, 4-10

Preflight check, 5-1

Pressure operated relay (see power change relay)

### Q

Quality, audio (see frequency response)

Quartz crystal (see crystal)

### R

Radio frequency circuits (see circuits)

Range switches (see switch)

Relays,

adjustment of, 5-43 thru 5-46

function of, 4-1 thru 4-6

inspection of, 5-1, 5-2

parts list (replaceable), 5-47, 5-49, 5-51, 5-53, 5-55 thru 5-58

Remote (see pilot's control unit)

Report of failure, ix

Reset controls (see overload relays)

Resistance measurement chart, 5-15 thru 5-20A

Resistor,

color code, 6-13, 6-18, 6-19

### S

Schematics (see list of illustrations)

Screen voltage,

chart, 5-10 thru 5-14

how applied, 4-6, 4-9, 4-12, 4-14, 4-15

Security notice, following title page

Servicing,

dynamotor, 5-1, 5-21

relays, 5-43 thru 5-46

transmitter, 5-5 thru 5-46

tubes, 5-3 thru 5-5

Shockmount, installation, 2-3

Sidetone,

amplifier, 2-13, 2-14, 4-8, 4-9, 5-5, 6-1

check, 5-1, 5-4, 5-5

jacks, 1-4, 2-6, 3-1, 3-2, 4-8, 4-9

output control, 2-13, 2-14, 3-1

transformer, 4-8

Specifications,

general, 6-22 thru 6-24

Speech amplifier, 1-2, 4-6, 4-7, 5-4

Switch,

Autotune interlock, 4-20 thru 4-24

Autotune limit, 4-20 thru 4-24, 5-38, 5-39

Autotune seeking, 5-37, 5-38

channel selector, 4-20 thru 4-24

emission selector, 4-5, 4-6, 5-38

high frequency range, 4-12, 4-13, 5-23, 5-24

keying interlock, 3-0, 4-6, 4-24

loading capacitor range extension (see control "E")

local-remote, 2-7, 4-3, 4-4, 4-20

low frequency coarse tuning (see control "F")

metered circuit selector, 3-1

microphone, 1-2, 2-1, 2-8

multiplier range, 4-13 thru 4-14

oscillator selecting (see control "A")

output network (see control "C")

power level, 3-1, 4-1, 4-3, 4-6, 4-10

test (key), 1-4, 3-1, 4-5, 4-6

vacuum contact, 5-44, 5-45

Symbol designations (table of), 7-1

### T

Tables,

accessories for complete installation, 1-7

antenna—power output, 1-2, 1-3, 6-23

antenna tuning data, 3-21 thru 3-26

bulk spare parts list by symbol designation (see note 1 page 7-53)

bus-bar code, 6-22

capacitor color codes, 6-11 thru 6-18

complete AN/ART-13 equipment, 1-5 thru 1-7

equipment required for operation but not supplied, 1-7

equipment supplied on contract, 1-5, 1-6

frequency range of control "A" positions, 4-13, 6-22

general specifications of equipment,

antenna requirements, 6-23

dimensions and weights, 8-1 thru 8-18

dynamotor specifications, 6-23, 6-24

frequency bands, 6-22

frequency stability,

with temperature change, 6-22

with humidity change, 6-22, 6-23

power input, output, 6-23

glossary of United States-British terms used, 6-35

HF tuning—coarse, 4-13

HFO calibration data, 3-6 thru 3-16, 6-6 thru 6-8

hookup wire code, 6-19 thru 6-22

interchangeability of units, 1-9

LFO calibration data, 3-4, 3-5, 6-4, 6-5

list of manufacturers, 7-54, 7-55

MCW-CFI unit output level, 6-2, 6-3

operation of network switch, 4-16

parts list by symbol designation, 7-2

parts lists for Autotune motors, 5-60, 5-64, 5-66, 7-47

parts lists for dynamotors, 5-68, 5-69, 5-73, 5-74, 5-76

parts list for relays, 5-47, 5-49, 5-51, 5-53, 5-55 thru 5-57

parts list for pilot's control unit key, 5-59

power output with frequency, 1-2, 1-3, 6-23

replaceable parts (by symbol designation), 7-2

## Index

## AN 08-30ART13-5

- replaceable Autotune parts, 5-39, 5-40, 7-53
  - sidetone output voltage table, 2-14, 6-1
  - symbol designation table, 7-1
  - tolerance values of capacitors, 6-13 thru 6-18
  - tube complement, 6-24
  - typical audio frequency data, 6-1
  - typical power input requirements, 1-3, 6-1
  - typical servicing problems, 5-6 thru 5-9
  - Telegraph key (see key)
  - Terms used,
    - glossary of United States-British, 6-35
  - Throttle switch,
    - cord-plug, 1-7
    - jack, 3-1
  - Tone oscillator (see MCW oscillator)
  - Transmitter,
    - controls, 2-7, 2-8, 2-13, 3-0, 3-1, 4-1 thru 4-24
    - data, 6-1 thru 6-34
    - dimensions, 8-1
    - installation drawing, 8-1
    - mounting, 2-3, 8-3 thru 8-6
    - overload relay, 1-4, 2-3, 2-7, 5-6
    - practical wiring diagram, 8-27
    - RESET (see overload relay)
    - schematic, 8-21
    - unit assembly, 1-1, 5-21 thru 5-24
    - units, 1-1, 5-21 thru 5-24, 5-40
  - Transformer,
    - audio driver, 4-7
    - audio input, 4-7
    - modulation, 4-7, 4-8
    - sidetone output coupling, 4-8
  - Tripler (see multiplier)
  - Trouble shooting,
    - accessories for, 5-4, 5-5, 5-27, 5-30, 5-32, 5-33
  - Tools, 1-8, 5-5, 5-30
  - Tube (see vacuum tube)
  - Tuning,
    - antenna, 1-2, 3-17 thru 3-26, 6-23
    - charts, 3-20 thru 3-26
    - controls, 3-0, 3-1
    - instructions, LFO, HFO, 2-8 thru 2-13, 3-2, 3-3, 5-24 thru 5-27
    - CFI, 5-31 thru 5-33
- U**
- Uncrating, 2-1
  - Units,
    - external, 1-4 thru 1-9
    - transmitter, 1-1, 5-21 thru 5-24, 5-40, 5-41
  - Unit function,
    - audio, 4-6 thru 4-9
    - Autotune, 4-24
    - CFI, 4-9, 4-10
    - HFO, 4-12, 4-13
    - LFO, 4-10 thru 4-12
    - multiplier, 4-13, 4-14
- V**
- Vacuum contact, 5-44, 5-45
  - Vacuum tube,
    - complement, 6-24
    - data, 6-25 thru 6-34
    - failure, 5-3 thru 5-5
    - replacement of, 2-1, 2-2, 6-24
  - Variometer, 3-0, 4-16, 4-24, 8-47, 8-48, 8-52, 8-53, 8-57
  - Voice,
    - monitoring, 2-13, 2-14, 5-4, 5-5
    - operation, 1-2, 2-13, 4-5, 4-6, 5-1
    - operation servicing, 5-4, 5-5
    - relay, 4-1, 4-3, 4-5, 5-45, 5-51, 5-52
  - Voltage and current measurement chart, 5-10 thru 5-14
- W**
- Warning, x
  - Weight,
    - of major units, 1-5, 1-6, 8-1 thru 8-18
  - Wire,
    - color code, 6-19 thru 6-22
- Z**
- Zero beat (see CFI oscillator calibration)